



Assembly Guide DCS5_DCS5A_DCS6_2015_B

Check out our other products online at
www.copernicused.com

For assistance, please contact us:

1-800-267-8494

Email info@copernicused.com

Have your packing slip ready for reference

WARNING !

- This product is meant to be assembled by an adult.
- In its unassembled state, small parts present a hazard.
- To be used under direct supervision of an adult.

Patent Pending

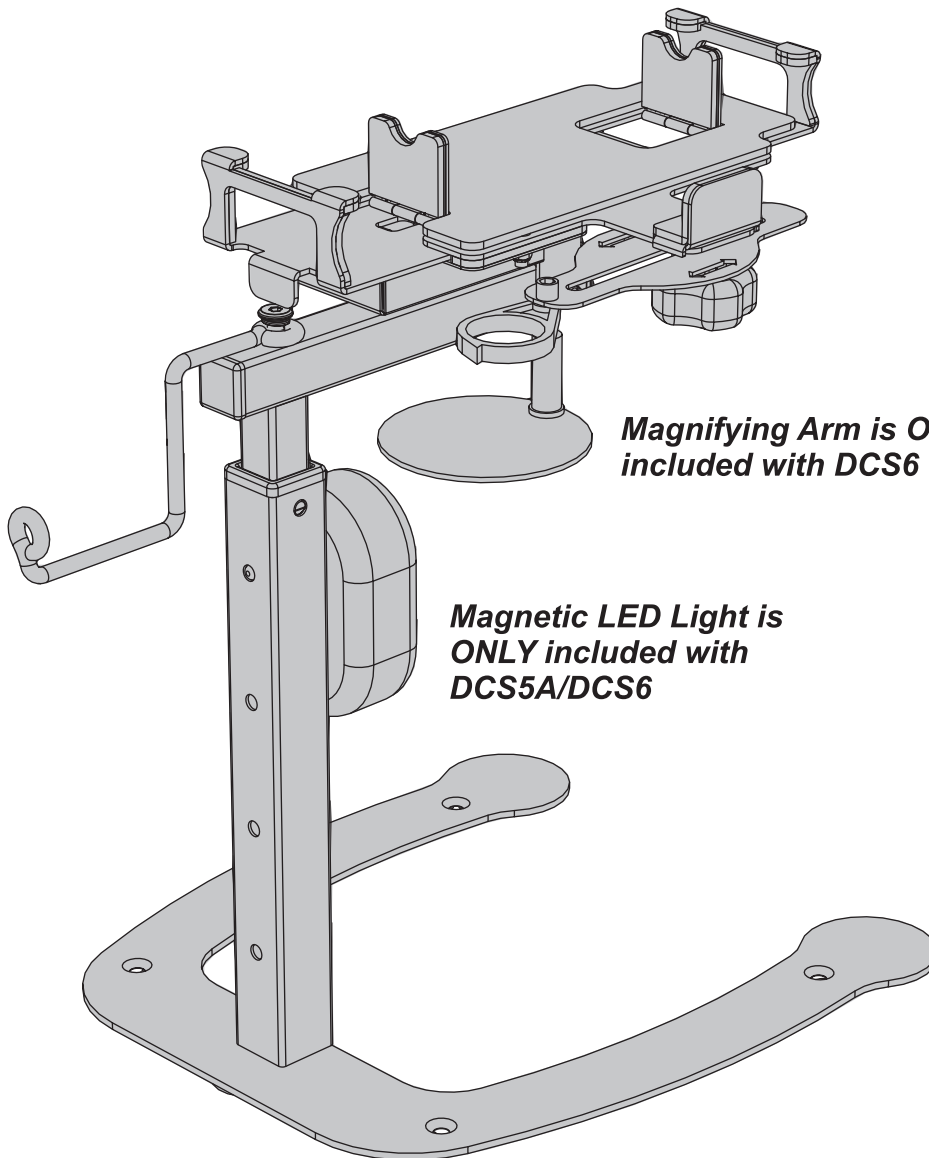

Magnifying Arm is ONLY included with DCS6

Magnetic LED Light is ONLY included with DCS5A/DCS6

Touchboards

205 Westwood Ave, Long Branch, NJ 07740
Phone: 866-94 BOARDS (26273) / (732)-222-1511
Fax: (732)-222-7088 | E-mail: sales@touchboards.com

Check out some of our other great products!



www.copernicused.com

*Need Tech Support?
Have a Question?*



Email our Tech Support Service

iPad® not included.
Document Camera and
Microscope Function only
works with most Smartphones
iPad mini™, iPad 2™ & Newer.





Warning! Hazard Risks!

Please read the warnings below for important safety information regarding your product. Failure to read these warnings or to follow the instructions below could result in personal injury or damage to your product that could void your warranty.



Small Parts

In its unassembled state, this product contains parts that can be hazardous to small children. This product should be assembled by an adult.



Adult Supervision

This product is to be used under the supervision of an adult.



Indoor Use Only

This product is intended for indoor use only. To reduce the risk of fire or electric shock, do not expose this product to rain or moisture. The internal components are not sealed from the environment.

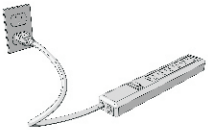

Powerbar Specifications

Read your powerbar's electrical specifications. Only plug in devices that are approved for use with this powerbar. Connect the supplied power bar directly to a wall outlet. **Do not connect to another power bar or use an extension cord.** Unplug when not in use.

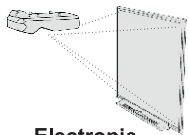

Electronic Equipment

Read the electrical specifications of any electronic equipment you are using with your Copernicus products. Failure to read these specifications and follow their instructions could result in damage to your equipment or personal injury.



Cable Trip Hazard

Ensure that any cables extending across the floor to your product are properly bundled and marked to avoid tripping or falling which may lead to personal injury.



Electrical Shock

Do not install or use the electrical components of this unit during a lightning storm.



Climb Hazard

Do not climb on, hang from or suspend objects from any components of your product unless otherwise specified.



Tips for Assembly



2 Person

Watch for These Helpful Symbols

- This symbol denotes a 2 Person Task. For safety, please ensure that there are two people working on steps displaying this symbol



- Watch for this symbol throughout the Assembly Instructions. Wherever you see it, pay close attention. The symbol denotes a step needing extra attention to ensure it is done correctly.



- The Star symbol highlights an advisory note

Before You Begin



- Layout and identify all of the included parts
- The hardware has been packed by step
- Read the assembly instructions over once to familiarize yourself with them
- Please note that in its unassembled state, this product contains parts that can be a hazard to small children; it should be assembled by an adult.



As You Assemble the Unit

- Follow the steps in sequence
- Before beginning each step, find the part(s) that you need for that step
- Pay attention to the labeling on the parts, they are there to help direct you at certain stages
- The title of each step states what you will be doing. Review the text and the pictures as you build the unit.



Validate Your Warranty On-Line

To validate your warranty submit the ON-LINE form at www.copernicused.com

“The beautiful thing about learning is that no one can take it away from you.” - B. B. King



Dewey the Document Camera Stand - Assembly Guide



WARNING

Please note that in its unassembled state, this product contains parts that can be hazardous to small children. This product should be assembled by an adult.

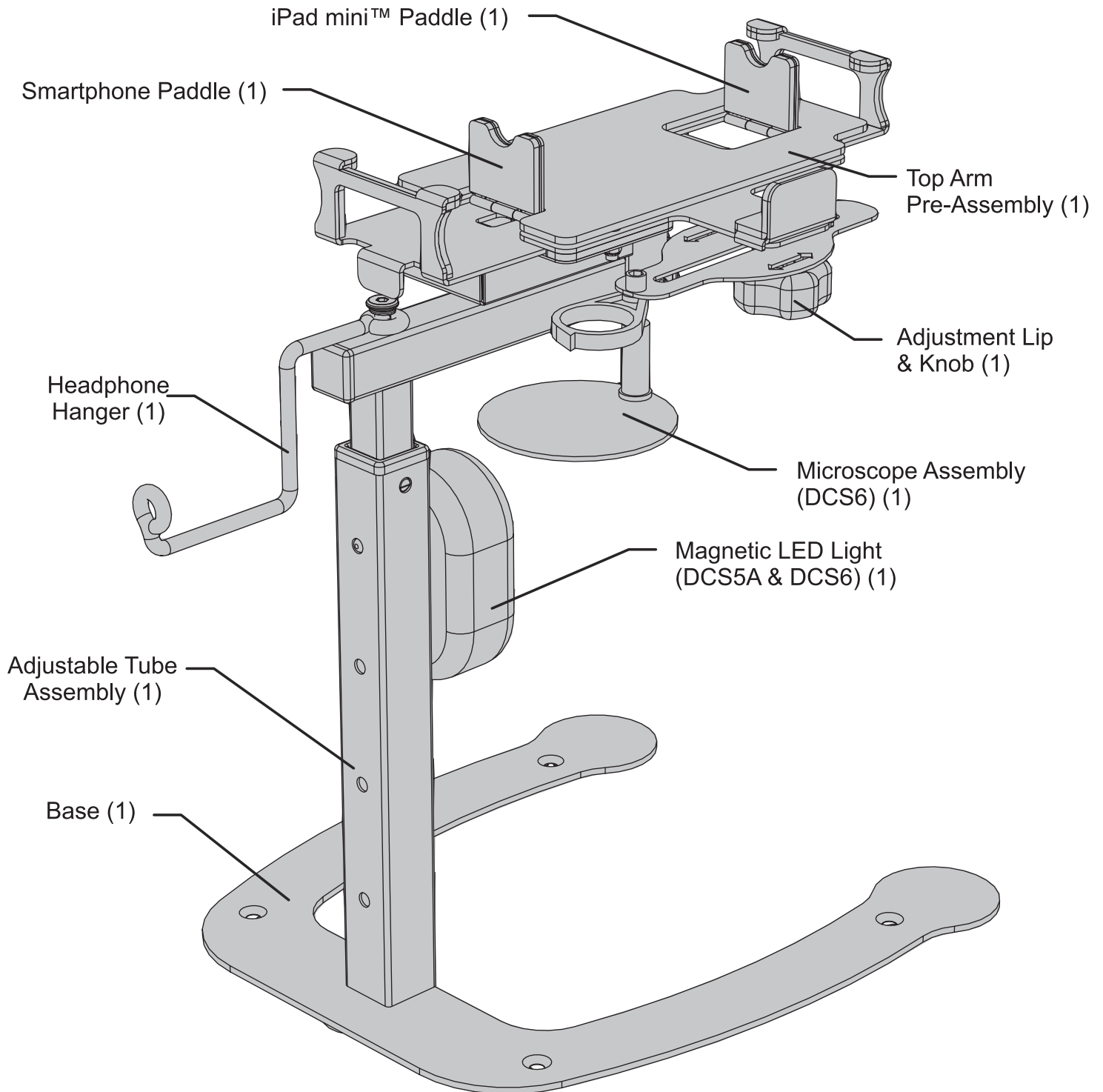

Dewey - Parts

Before beginning, you should have:

Contents - Box 1

Top Arm Pre-Assembly
1x

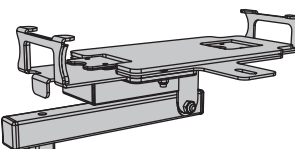

Adjustment Lip
1x

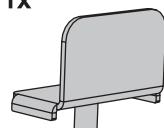

Positioning
Template
1x

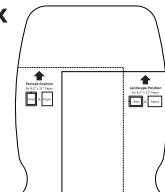

Adjustable Tube
Assembly
1x



VGA Strap
1x

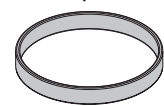

Headphone Holder
2x



Base
1x

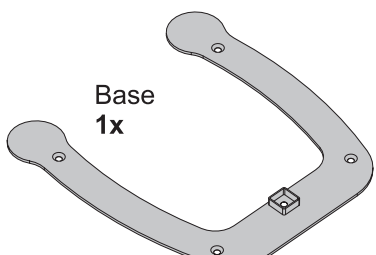

**Hardware
Actual Size**

(A) M6 x 20mm
1x



(B) M6 x 45mm
1x



(C) M6 Lock Washer
1x



(D) M6 Lock Nylon
Washer
2x



(E) M6 Knob
1x

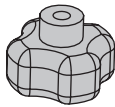

Allen Key
(Not to Scale)
1x



Extra Hardware
1x

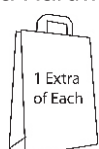

1 Extra
of Each

**Content - Box3
with DCS6**

Dewey Microscope
Assembly
1x

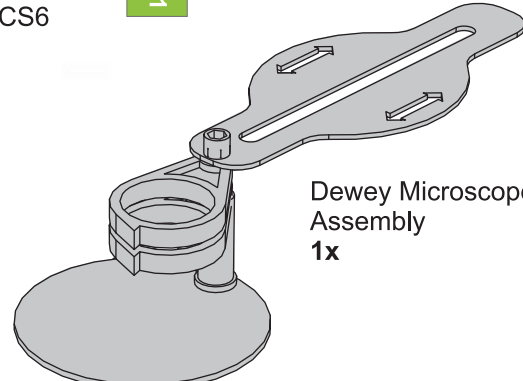

**Content - Box2
with DCS5A/DCS6**

Magnetic LED Light
1x

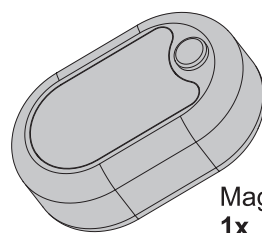

**Additional Items Needed
Not Included**

VGA
Cable
1x



Apple® VGA
Adapter
1x



Apple TV®
1x



iPad mini™, iPad 2™
or Newer
1x



Smartphone
1x



OR



1

Actual Size:

(A) M6 x 20mm
1x



You will need: (Not to Scale)

Adjustable Tube
Assembly
1x



Base
1x

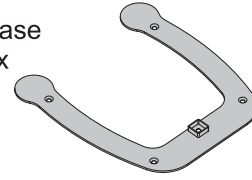

Assemble the Adjustable Tube Assembly to the Base

! Make sure the height adjustment holes are facing outwards, as seen in image.

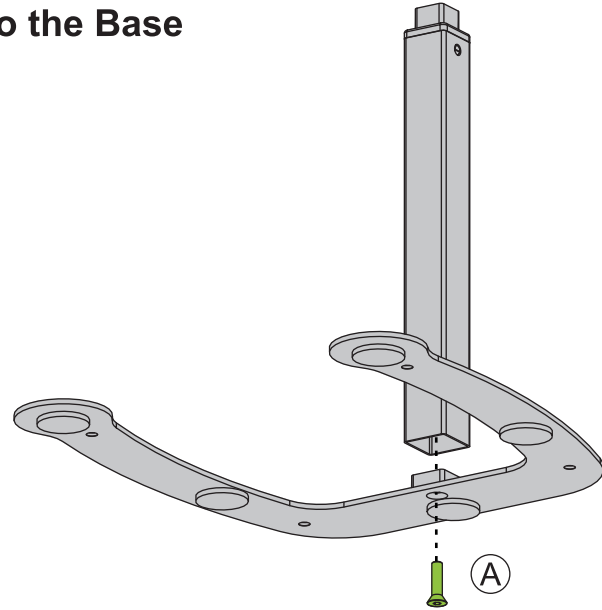
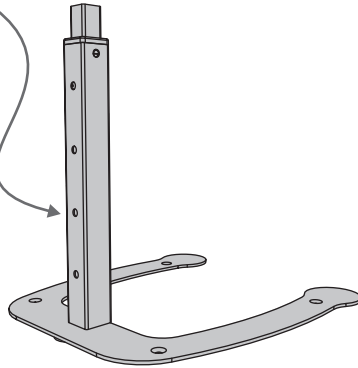

2

Actual Size:

(B) M6 x 45mm
1x



(C) M6 Lock Washer
1x



You will need: (Not to Scale)

Top Arm
1x

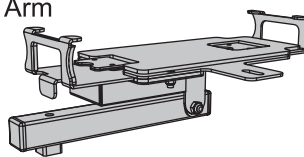

Headphone Holder
1x

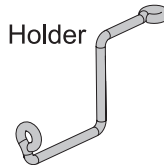

Assemble the Top Arm & Headphone Holder

To easily assemble the Top Arm, adjust the height to the lowest position then assemble the pieces together.

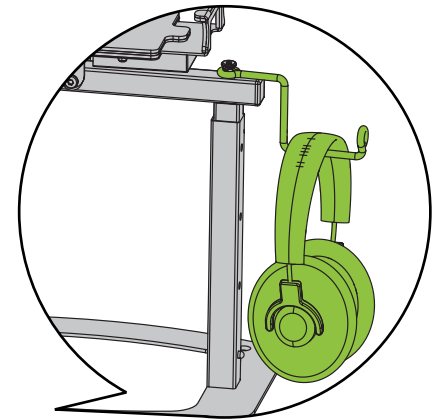
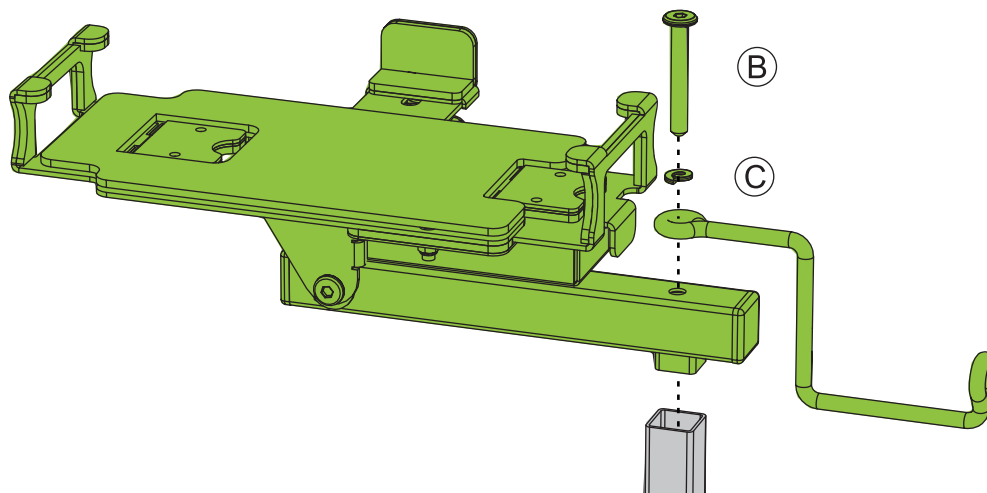

★ The headphone holder holds up to two headphones.



3A

Actual Size:



(D) M6 Lock Nylon Washer 2x

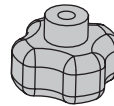

(E) M6 Knob 1x

You will need: (Not to Scale) Adjustment Lip 1x

FOR DCS5 and DCS5A ONLY

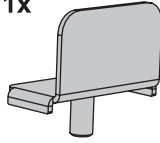

Attach Adjustment Lip and Knob to Top Arm Pre-Assembly.

Place threaded post on Adjustment Lip through hole. Tighten knob.

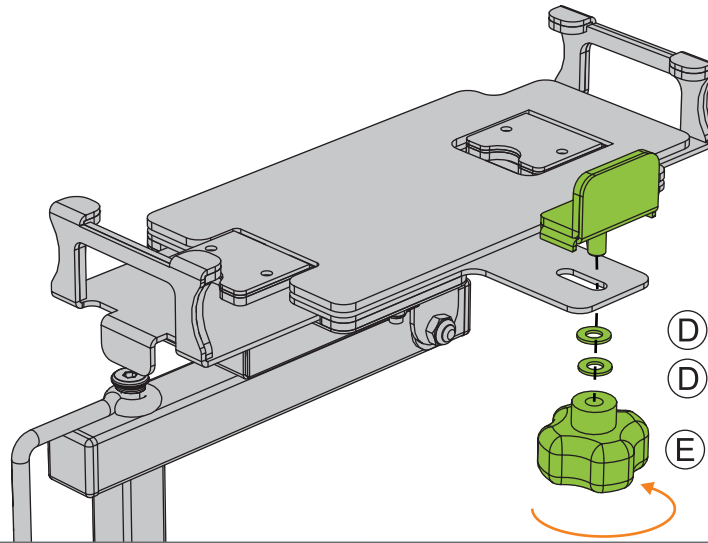

3B

Actual Size:



(D) M6 Lock Nylon Washer 2x

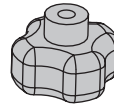

(E) M6 Knob 1x

You will need: (Not to Scale) Dewey Microscope Assembly 1x

FOR DCS6 ONLY



Adjustment Lip 1x

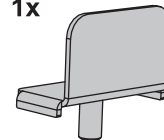

Attach Microscope Assembly to Top Arm Pre-Assembly.

Place threaded post on Adjustment Lip through hole and Microscope Arm. Tighten knob.

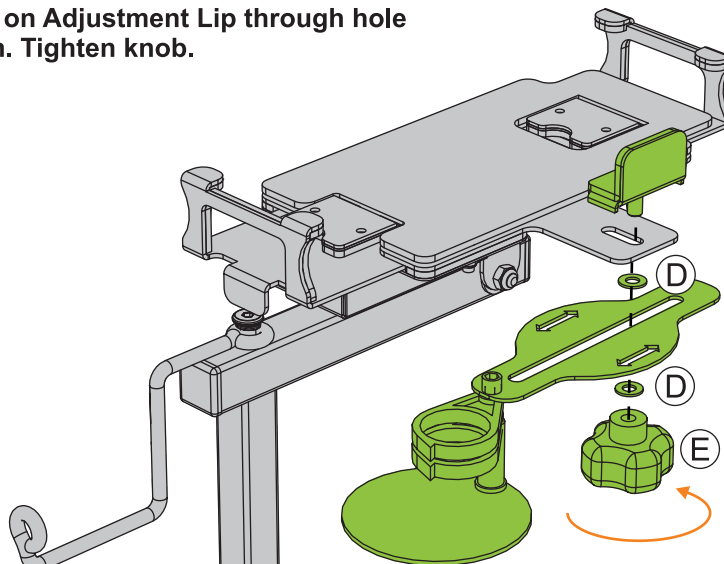

4

Actual Size:

You will need: (Not to Scale)

Positioning Template
1x

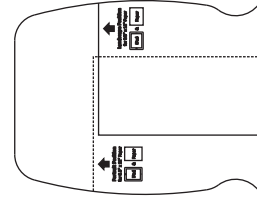

Position the Paper Template (OPTIONAL)

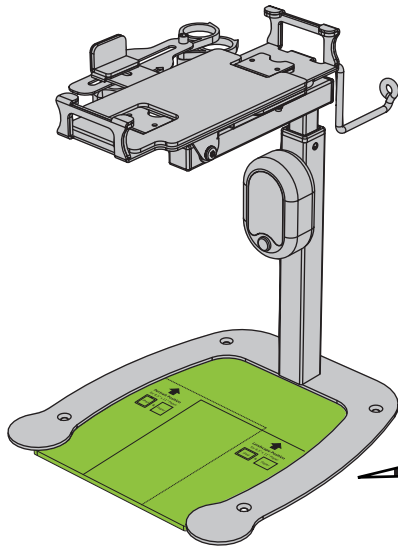

! Pay close attention to the orientation of iPad and 8.5"x11" paper. Then match the edge of the paper with the indicated line that the arrow points at. This helps to position your paper in the middle of your projection.

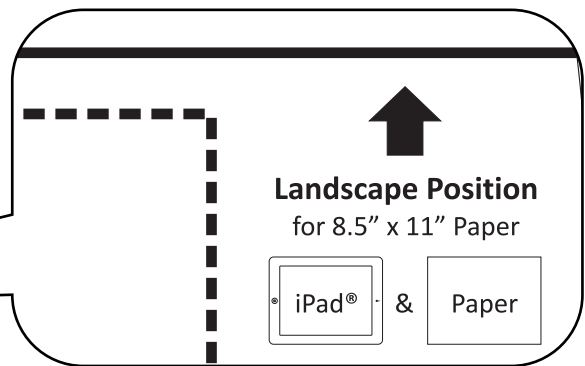

5

Actual Size:

You will need: (Not to Scale)

VGA Strap
1x

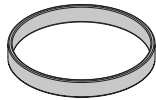

Apple® VGA Adapter
1x



iPad mini™, iPad®2 or Newer
1x

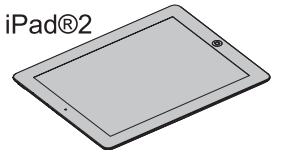

Use VGA Strap to Hold Apple VGA Adapter in Place (OPTIONAL)

To hold the VGA cable in place use provided VGA strap. Tie the strap around the adapter cable and then loop over the edge of the top mechanism.

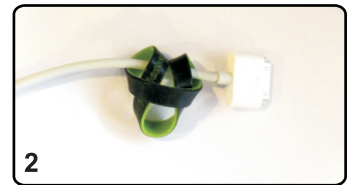
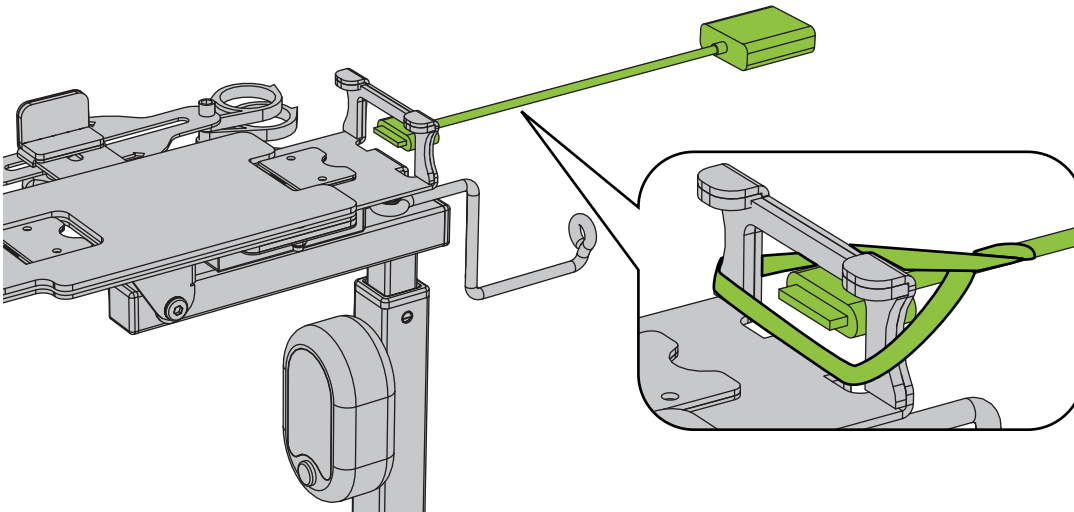

6

Actual Size:

OPTIONAL -
DCS5A/DCS6

You will need: (Not to Scale)

Magnetic LED Light
1x

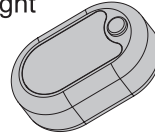

Positioning the Magnetic LED Light (OPTIONAL DCS5A and DCS6)

Use the magnet on the LED to attach it anywhere on Dewey's Neck.



Suggested spots to mount the
Magnetic LED Light without
getting hot spots.

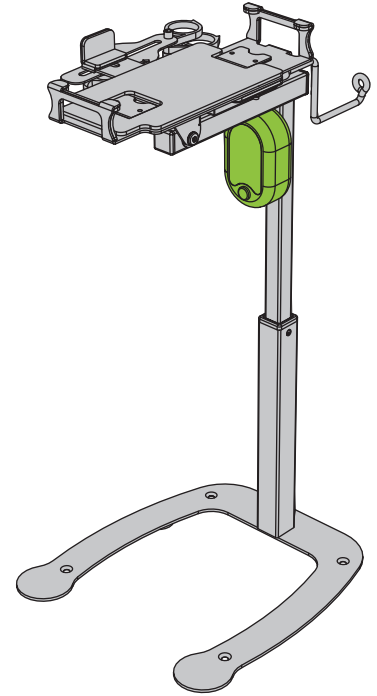
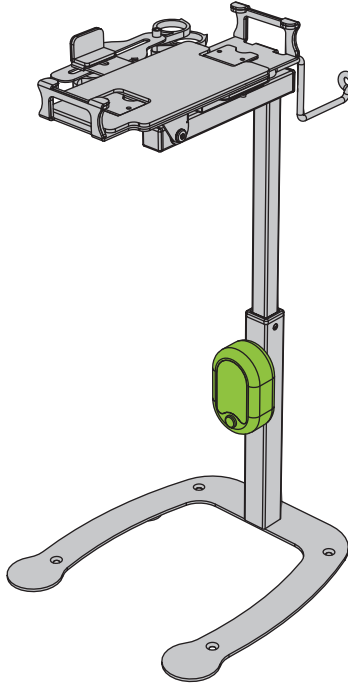
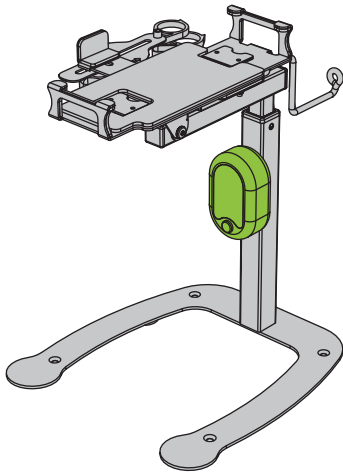

FOR DCS6 ONLY

When using the Microscope Assembly (DCS6) here are suggested locations for the LED to be mounted.

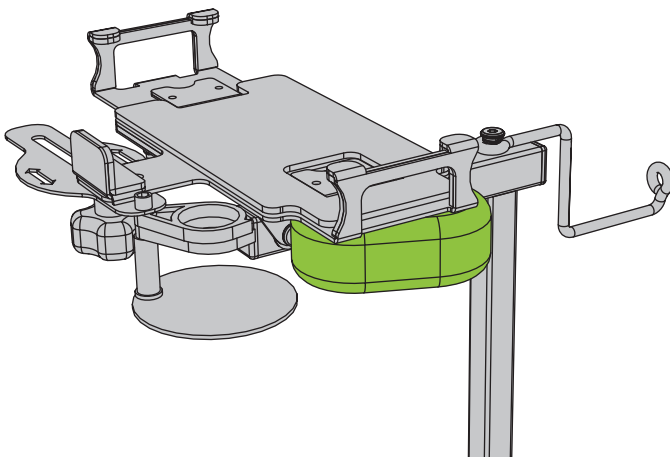

Tablet + Microscope Assembly

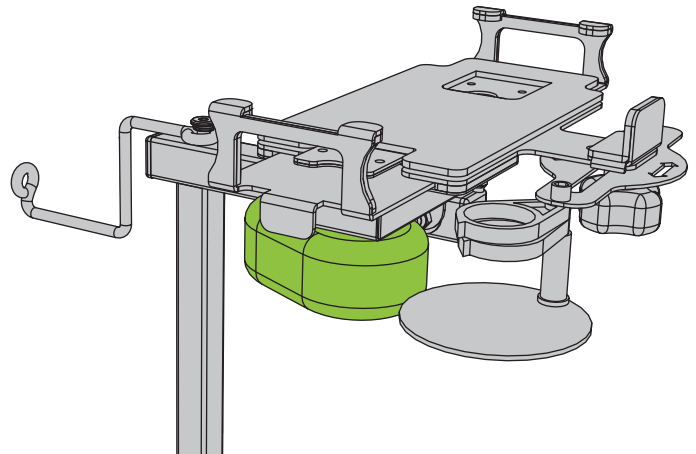

Smartphone + Microscope Assembly





To Change Projected Image

Holding onto top mechanism - turn iPad® 90 degrees

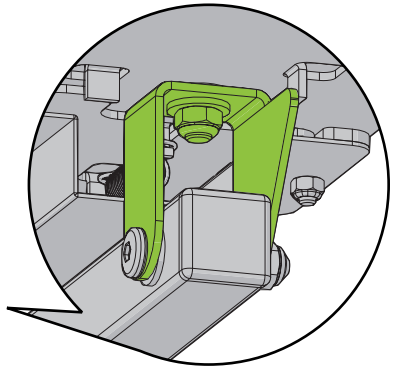
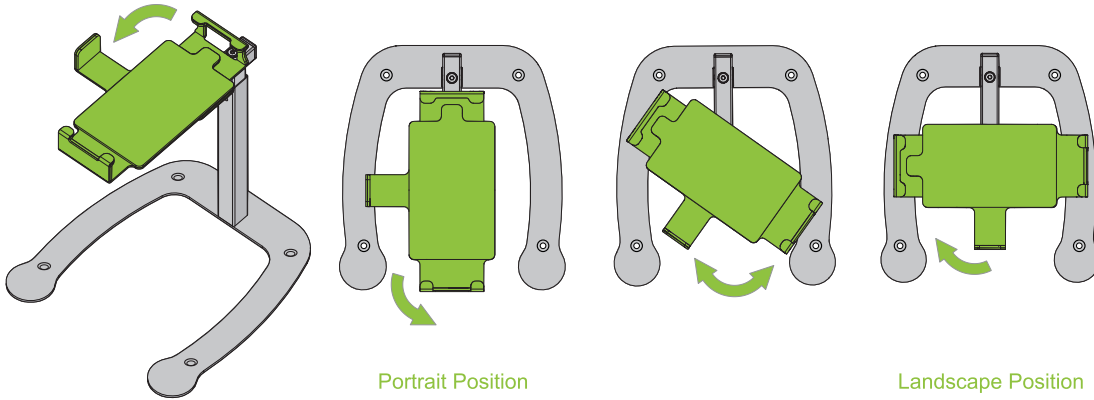

★ If swivel tension ever needs to be tighter, tighten this nut with 10mm wrench.

NOTE: Sometimes when you rotate the iPad® your projected image does not rotate, in that case you need to tilt down the top mechanism to allow the iPad® to adjust

Changing from Document Camera to Stand Position

Holding onto top Mechanism - tilt between Document Camera Position and Stand Position

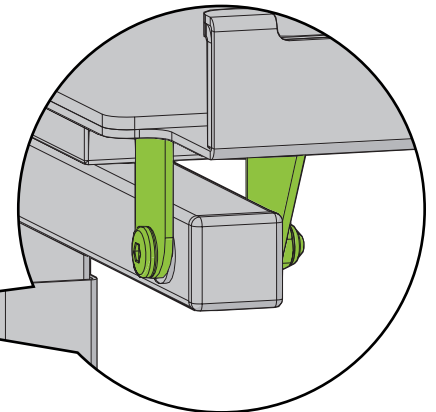
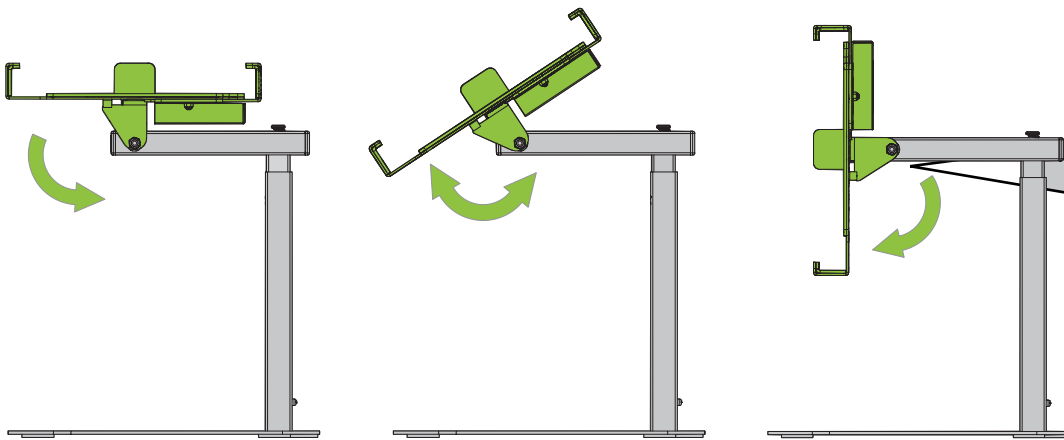

★ If folding tension ever needs to be tighter, tighten this nut & bolt with 10mm wrench and the provided allen

Securing Dewey to a Surface

Mount Dewey to a surface using the holes on the base.



The holes are made for 1/4" or M6 bolts/screws. The length of your hardware depends on your surface thickness.

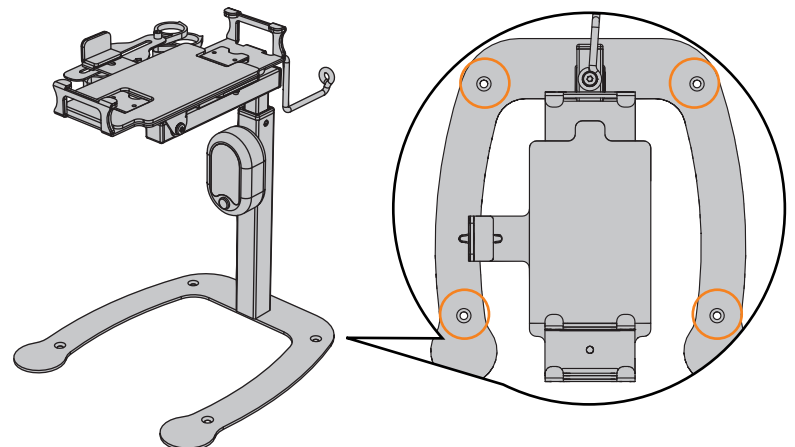



Using Dewey with 10" iPad®

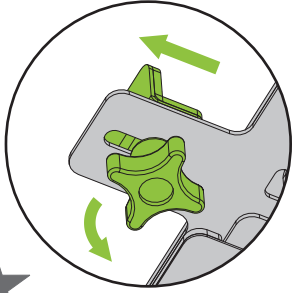

Loosen the Adjustment Lip Knob to slide the bottom lip out into the maximum position and tighten.

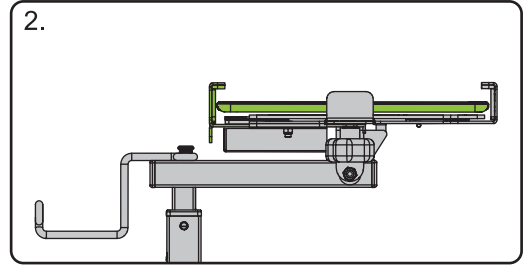
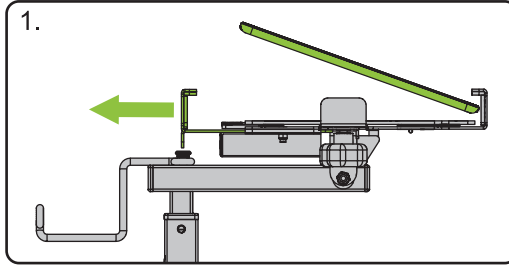

Using Dewey with iPad mini™

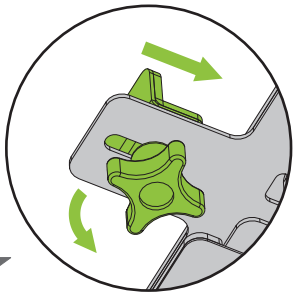

Loosen the Adjustment Lip Knob to slide the bottom lip into the minimum position and tighten.

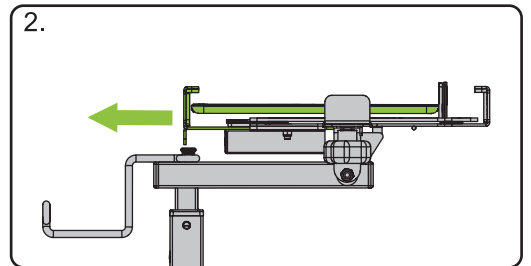
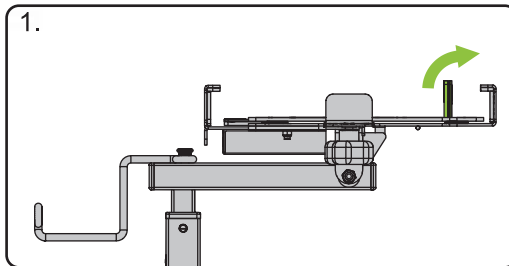

Using Dewey with Smartphones

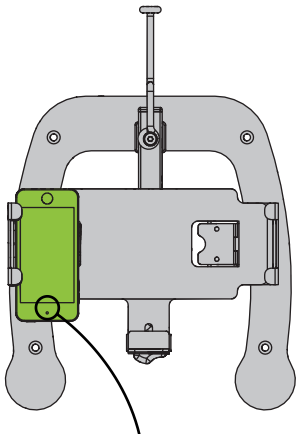

Camera on this side

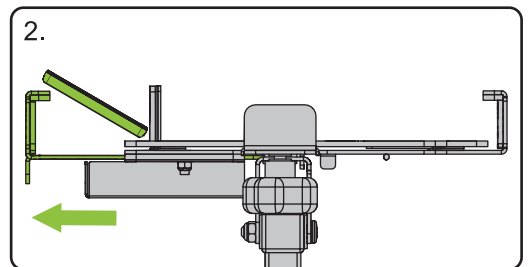
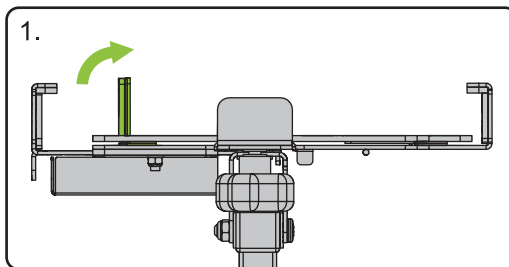

Smartphones must be used with Dewey in the Landscape position.





Microscope Assembly adjustments with Smartphones

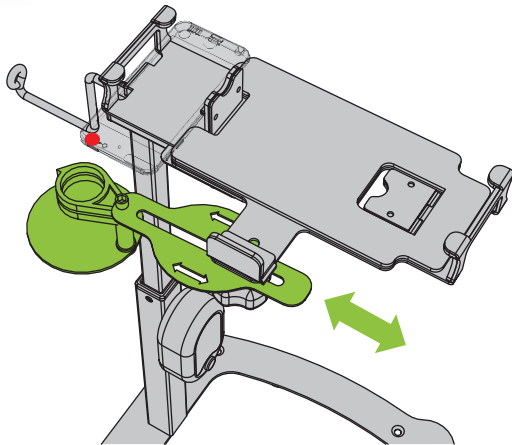

Loosen knob first to allow you to move Arm in and out to help position specimen under camera(●). Tighten knob.

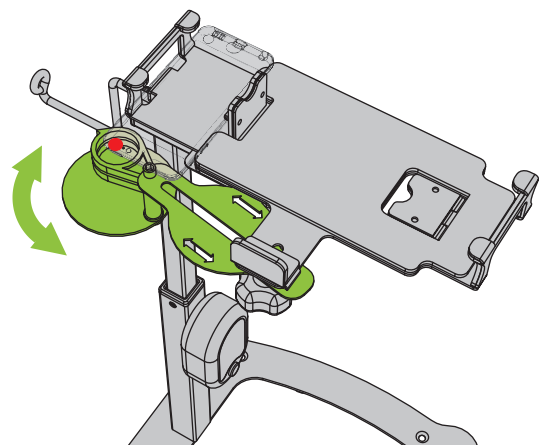

Arm, Lens and Stage can also swivel independently to help position specimen in view of camera(●).

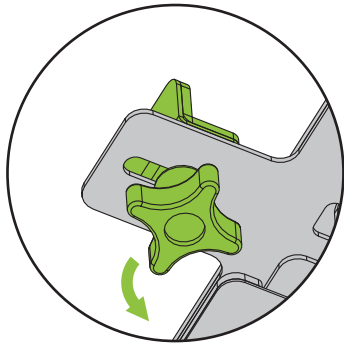

To switch from using Magnifying Arm with Smart Phone to iPad®:

Loosen knob slightly

Swing arm around to desired location

Tighten knob

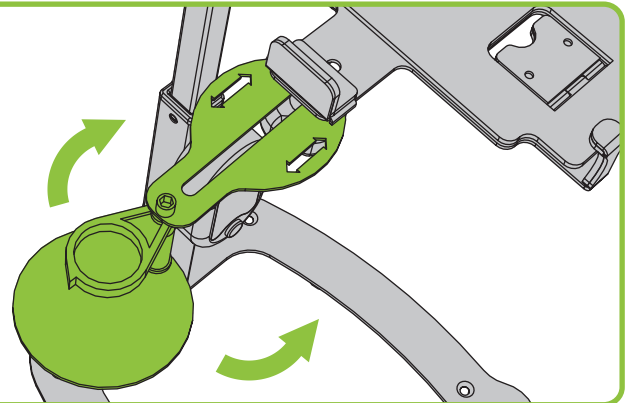

Magnifier Arm adjustments with iPad®

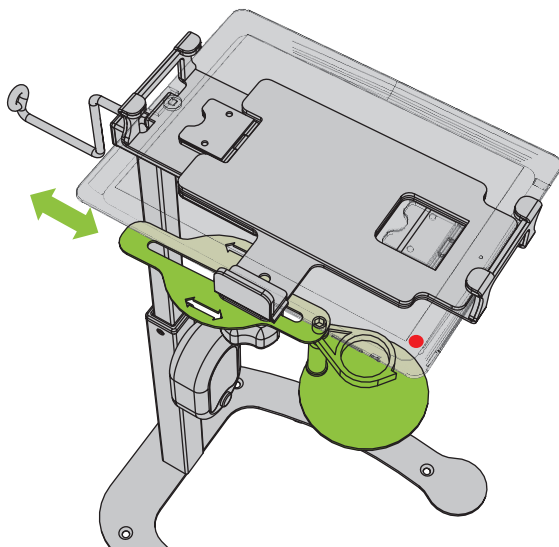

Loosen knob first to allow you to move Arm in and out to help position specimen under camera(●). Tighten knob.

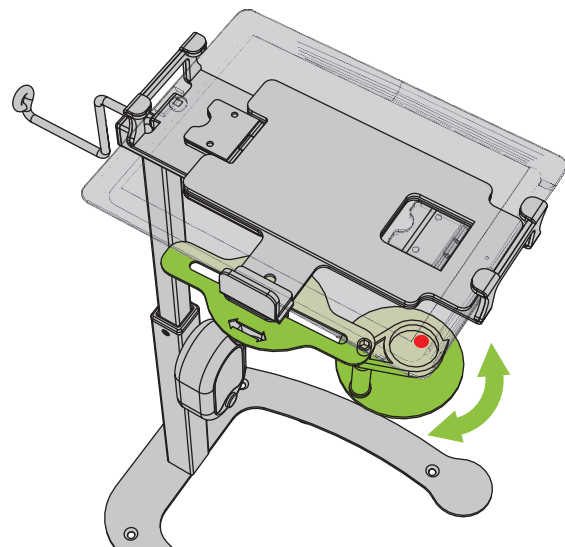

Arm, Lens and Stage can also swivel to help position specimen in view of camera(●).





Connecting to Your Projector

For iPad mini™, iPad 2™ or newer only:

Use Apple® VGA Adapter and a VGA cord (with two VGA male outlets) to connect projector to the iPad®.

OR Use Apple TV® to Connect wirelessly!

For Smartphones:

Use apps such as AllCast, Reflector or purchase a micro-USB to HDMI adapter.

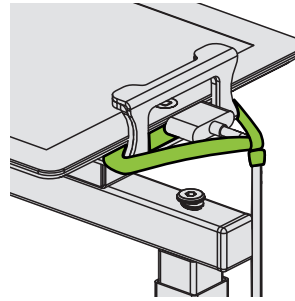

To hold the VGA cable in place use provided VGA Strap - Tie the strap around the VGA cable and then loop over the edge of the top mechanism.

Supported Paper Size

The Document Camera Stand covers surfaces from 13.25 x 10.0" up to 20.63" x 15.31" at different hole positions.

NOTE: The provided template is for positioning 8.5" x 11" paper.

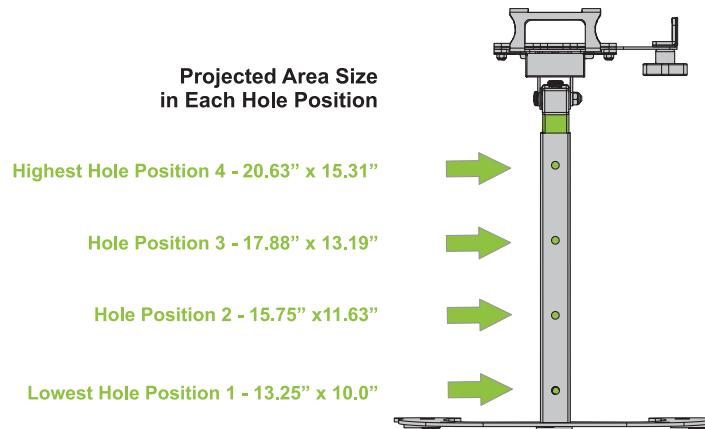

Suggested Apps

Smartphones, iPad mini™, iPad 2™ Or Newer:



Board Cam This app allows you to write on top of your image that you are projecting.



AllCast This app lets you send photos, music, and videos on your Android to your TV! You can cast to: Chromecast, Amazon Fire TV, Apple TV, Roku, WDTV, Samsung, Sony and Panasonic Smart TVs



Reflector Mirror your device on a big screen without wires or complicated setups. Play games, watch movies, demo apps or present on the big screen from your iPhone or iPad.



Educreations This app turns your iPad into a recordable whiteboard. It allows you to create a video tutorial. It has voice recording, realistic digital ink, photo imports, and simple sharing features.



Nearpod Student & Teacher Version This app enables teachers to use their iPads to manage content on student's iPads. Teachers version manages students content and flow of lecture. Students version receives content, participate in activities and submit responses.

NOTE: If the screen of your iPad® turns off while in use, adjust sleep mode time by going to **Setting>General>Auto-Lock**. And when you are not using your device put it into sleep mode.





Dewey the Document Camera Stand - Tips for Use

Basic Usage Tips

1. Position stand in lowest height

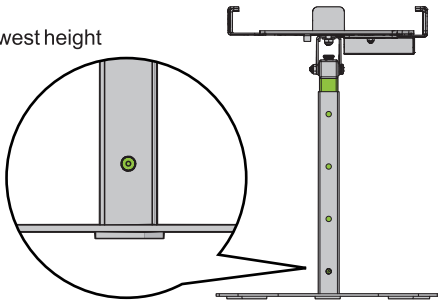

2. Place your iPad® into the stand.
(See point 3 & 4)

★ If your case has a flip cover, make sure it's open to the side.

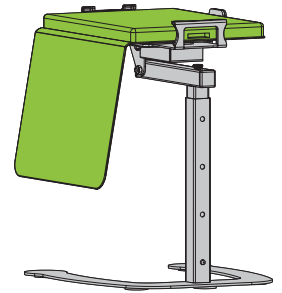

3. Match the openings in the top mechanism with the VGA outlet on your iPad®.

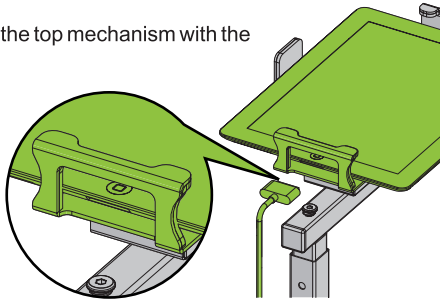

4. Place your iPad® or iPad mini™ into the top mechanism

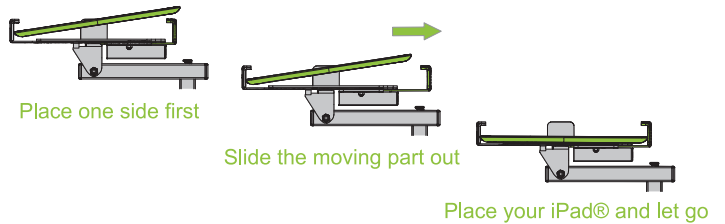

5. For document camera function use the rear camera of your iPad®

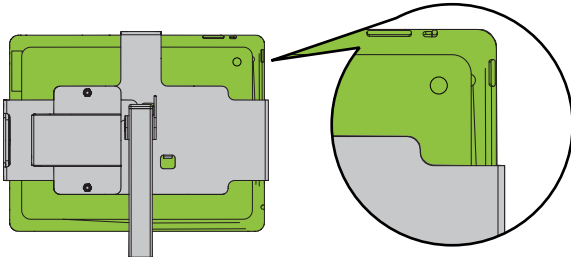

6. Use Apple® VGA Adapter to connect your iPad® to your projector

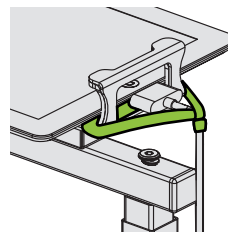

★ Use the provided VGA Strap to hold your VGA Adapter in place and stop it from being disconnected

7. Launch camera app and adjust desired height by sliding the Document Cameras' neck up/down.

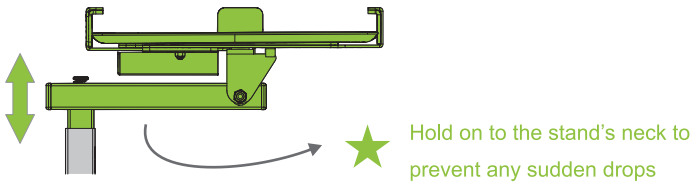

8. The Provided template helps locate your 8.5" x 11" paper without looking through the camera. (Optional)

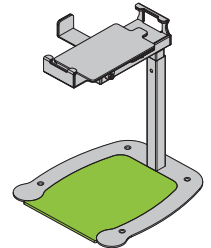
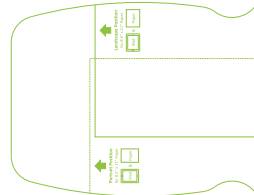

9. By rotating the top mechanism 90 degrees, change between landscape and portrait projection.

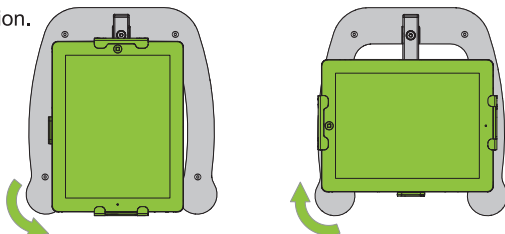

10. By tilting down the top mechanism, switch between document camera and stand position.

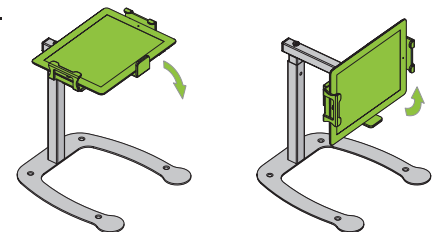



Assembly Guide DCS5_DCS5A_DCS6_2015_B

Check out our other products online at
www.copernicused.com

For assistance, please contact us:

1-800-267-8494

Email info@copernicused.com

Have your packing slip ready for reference

Dear Educator,

Thank you for purchasing one of our products.

I hope the assembly of your **Dewey - the Document Camera Stand** went well.

If you have any questions, or concerns, or ideas for how we can improve, please call us at 1-800-267-8494, where someone will be happy to help.

Enjoy using your new product, and happy teaching,

Jim Phillips
President



205 Westwood Ave, Long Branch, NJ 07740
Phone: 866-94 BOARDS (26273) / (732)-222-1511
Fax: (732)-222-7088 | E-mail: sales@touchboards.com

Quality schools are the result of quality teachers going above and beyond the call of duty.

VICKI CARUANA

In everyone's life at some time our inner fire goes out. It is then burst into flame by an encounter with another human being. We should all be thankful for those people who rekindle the inner spirit.

ALBERT SCHWEITZER

My idea of education is to unsettle the minds of the young and inflame their intellects.

ROBERT MAYNARD HUTCHINS

Nothing has a better effect upon children than praise.

SIR PHILLIP SIDNEY

