



Owners Manual, 2021 Rev A

Check out our other products online at www.copernicused.com

For assistance, please contact us by telephone at **1-800-267-8494** or email at info@copernicused.com.

Have your packing slip ready for reference.

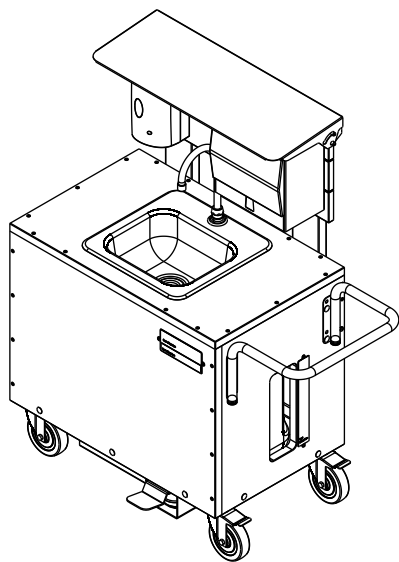

**Portable Outdoor Sink
PreK-5
Counter Height 29"
Premium Model
(SNK500)**

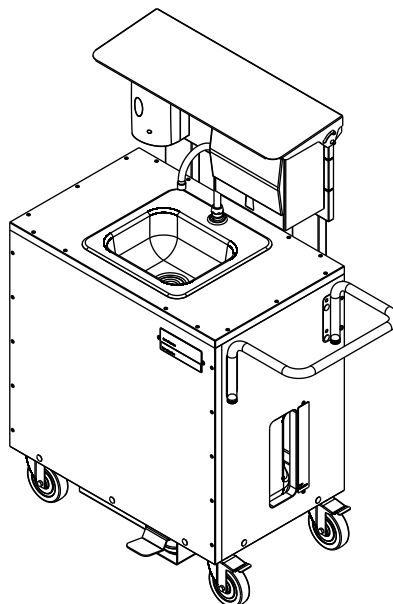

**Portable Outdoor Sink
Grades 6+
Counter Height 35-1/2"
Premium Model
(SNK600)**

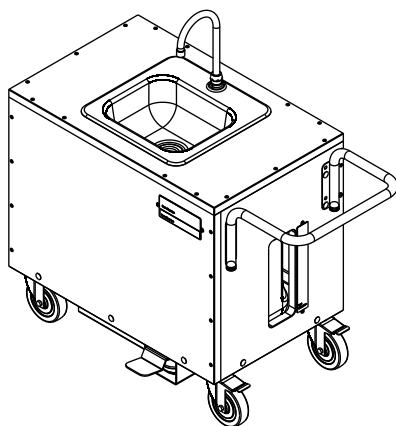

**Portable Outdoor Sink
PreK-5
Counter Height 29"
Base Model
(SNK501)**

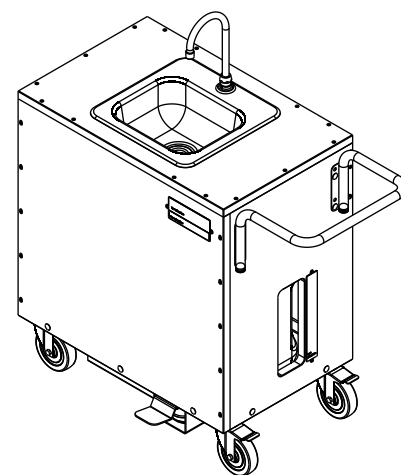

**Portable Outdoor Sink
Grades 6+
Counter Height 35-1/2"
Base Model
(SNK601)**



Customer Service & Warranty Information

Dear Educator,

Thank you for purchasing the Portable Outdoor Sink. We hope it meets your expectations and you and your students enjoy using it at your school.

Every day we see and hear stories of teachers going above and beyond to help students thrive. Thank you so much for all you do - you are awesome, and you make a difference.

Thanks for inspiring us.

If you have any questions, concerns or ideas on how we can improve please let us know by contacting our Customer Solutions Ninjas at 1-800-267-8494 or info@copernicused.com.

Happy teaching,

Kaylyn Belcourt, President
kaylyn@copernicused.com



We do not inherit the earth from our ancestors, we borrow it from our children.

- NATIVE AMERICAN PROVERB

Change is the end result of all true learning.

- LEO BUSCAGLIA

What you leave behind is not what is engraved in stone monuments, but what is woven into the lives of others.

- PERICLES

Education is the most powerful weapon which you can use to change the world.

- NELSON MANDELA

For missing parts and other issues regarding your product:

Please contact Customer Service, where we will be happy to help.

Telephone: 1-800-267-8494, Monday - Friday 8:00am - 4:30 pm EST

Email: info@copernicused.com

**Need Support?
Have a Question?**



[Email Customer Service](mailto:info@copernicused.com)

**Check out some of our
other great products!**



www.copernicused.com

Lifetime
Frame Warranty

Register your Product

Registering your warranty ensures we have all the information we need to make any future warranty claims quick and easy. Please visit www.copernicused.com/warranty and complete the form within 10 business days from product assembly. By registering your product, you will be entered into a draw to win Copernicus product.

2 Year
Plumbing
Components
Warranty

Make a Warranty Claim

We offer a Lifetime Warranty on almost everything we make. Please call 1-800-267-8494 or email info@copernicused.com to start your warranty claim. Proof of purchase will be required upon warranty claim (i.e. copy of invoice).

Tips for Assembly

Before You Begin:

- Lay out and identify all of the included parts.
- The hardware has been packed together in one bag
- Read the assembly guide over once to familiarize yourself with them.

As You Assemble the Unit:

- Follow the steps in sequence.
- Before beginning each step, find the part(s) that you need for that step.
- The title of each step states what you will be doing. Review the text and the pictures as you build the unit.

Watch for These Helpful Symbols:



2-Person Task

For safety, please have someone help you when working on steps displaying this symbol.



The symbol denotes a step needing extra attention to ensure it is done correctly.



Important Information! Warning!

Please read the warnings below for important safety information regarding your product. Failure to read these warnings or to follow the instructions below could result in personal injury or damage to your product that could void your warranty.



Small Parts

In its unassembled state, this product contains parts that can be hazardous to small children. This product should be assembled by an adult.



Adult Supervision

This product is to be used under the supervision of an adult.

Parts

Before beginning, you should have:

Additional tools required:

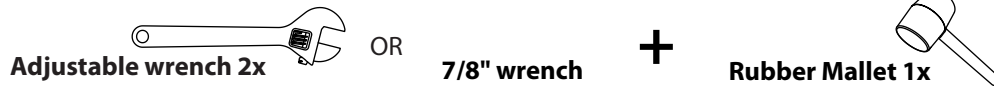

SNK500

Pre Assembled SNK500
1x

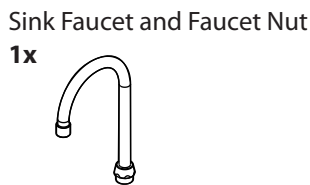
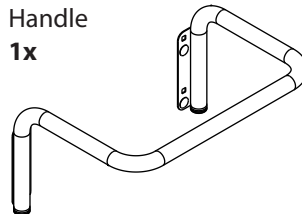
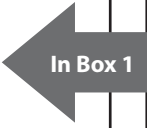
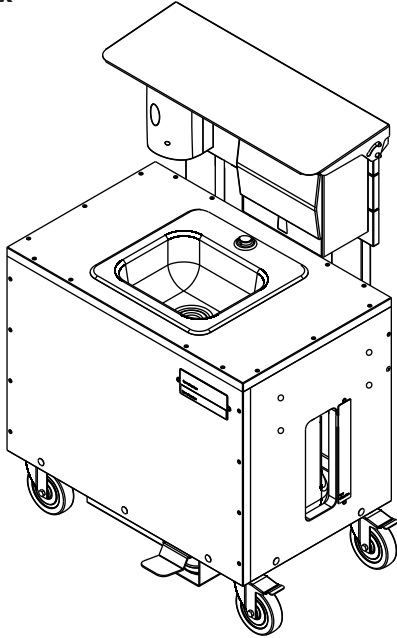

Hardware Actual Size

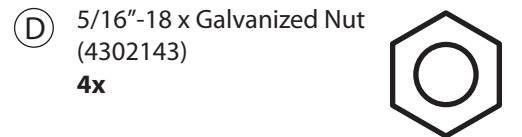
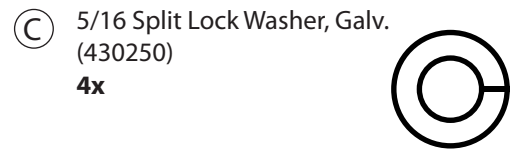
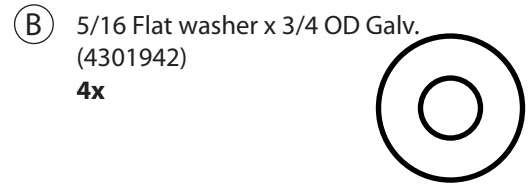
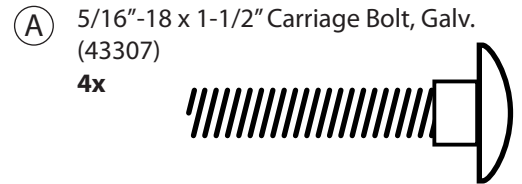

SNK501

Pre Assembled SNK501
1x

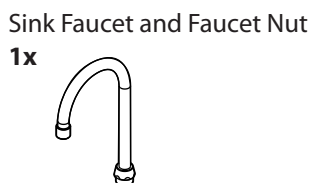
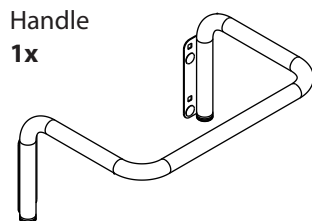
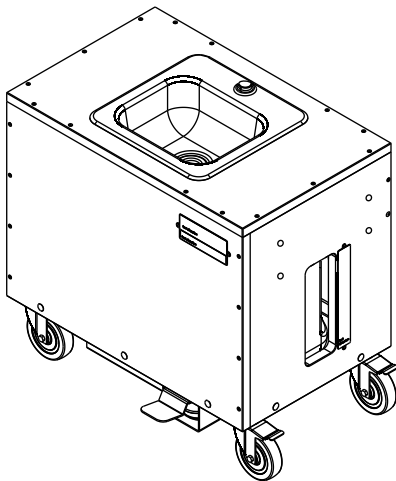

Parts

Before beginning, you should have:

Additional tools required:

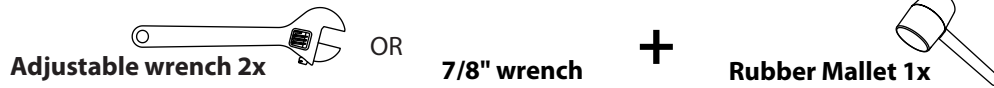

SNK600

Pre Assembled SNK600
1x

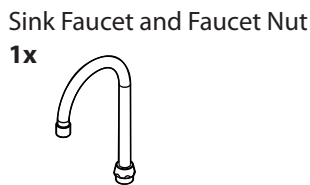
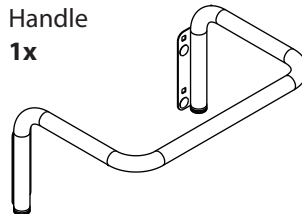
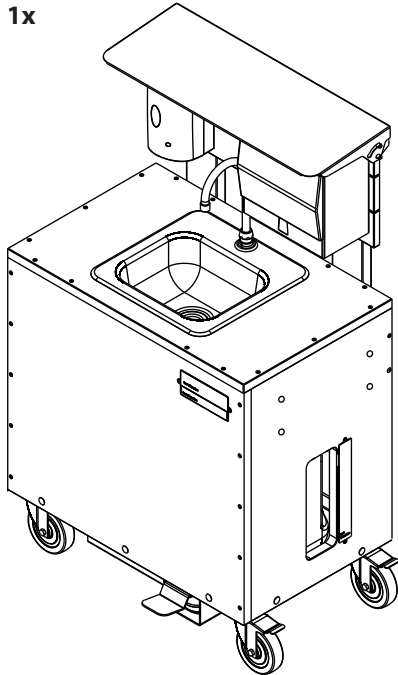

Hardware Actual Size

(A) 5/16"-18 x 1-1/2" Carriage Bolt, Galv.
(43307)
4x



(B) 5/16 Flat washer x 3/4 OD Galv.
(4301942)
4x



(C) 5/16 Split Lock Washer, Galv.
(430250)
4x

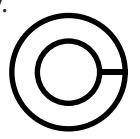

(D) 5/16"-18 x Galvanized Nut
(4302143)
4x



SNK601

Pre Assembled SNK601
1x

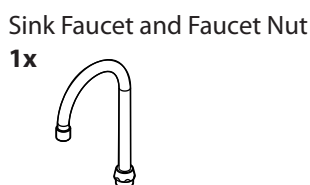
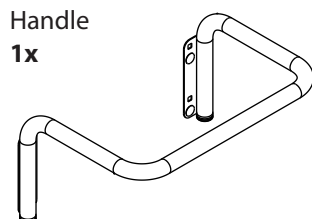
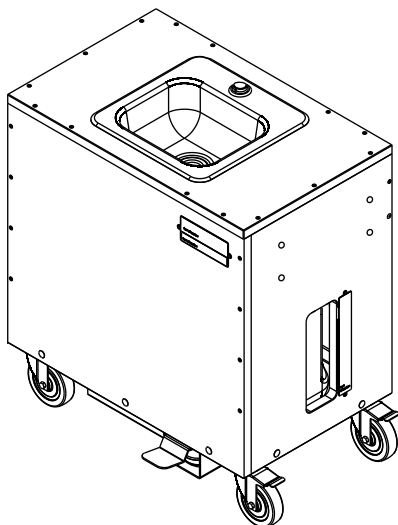

1

You will need: (Not to Scale)

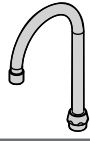

Sink Faucet and Faucet Nut
1x

Attach Faucet

Insert Faucet into receptacle on sink and tighten faucet nut

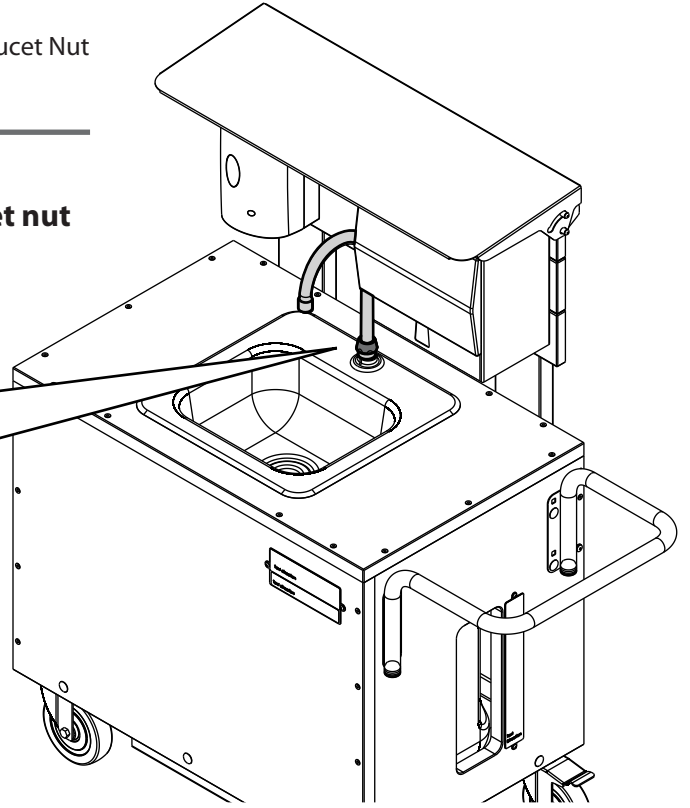
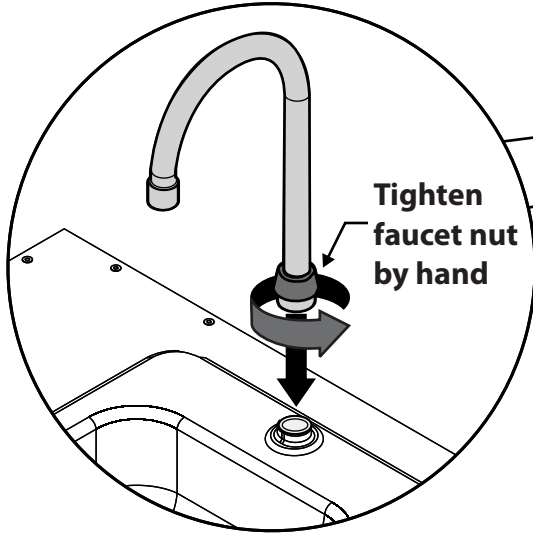

2

Remove Rear Panel

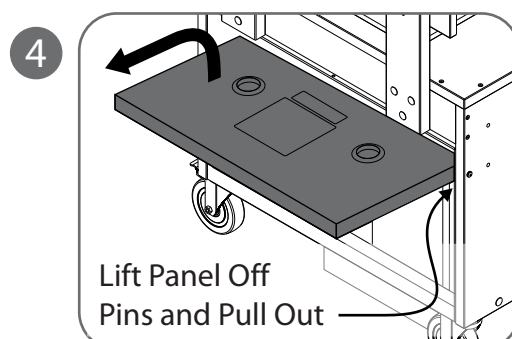
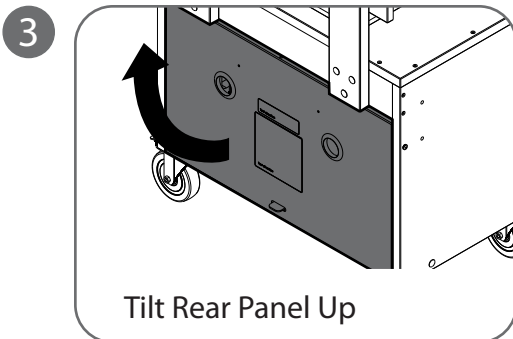
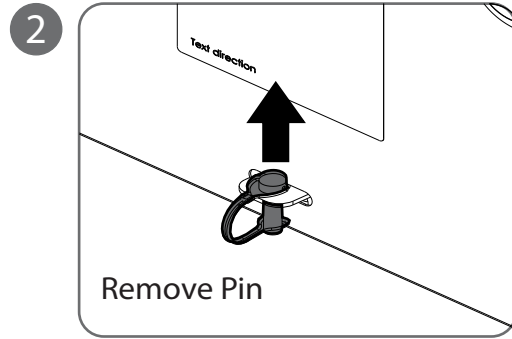
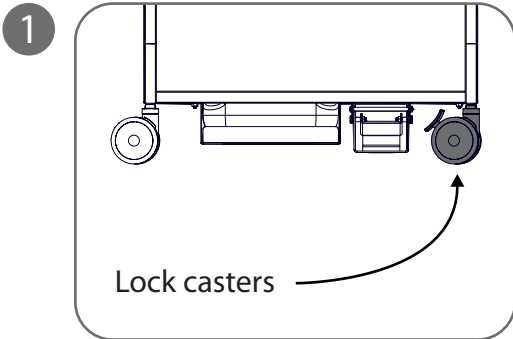

3

Actual Size:

(A) 4x



(B) 4x

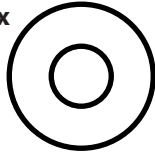

(C) 4x

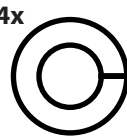

(D) 4x

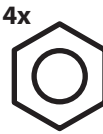

You will need: (Not to Scale)

Handle

1x

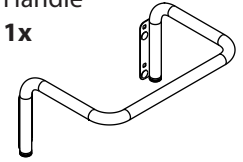

Fasten Handle onto Sink

- 1 Insert Carriage Bolts into Handle Mounting Plates (use hole positions 1 and 3(see diagram below))
- 2 Fasten Handle onto Sink cabinet

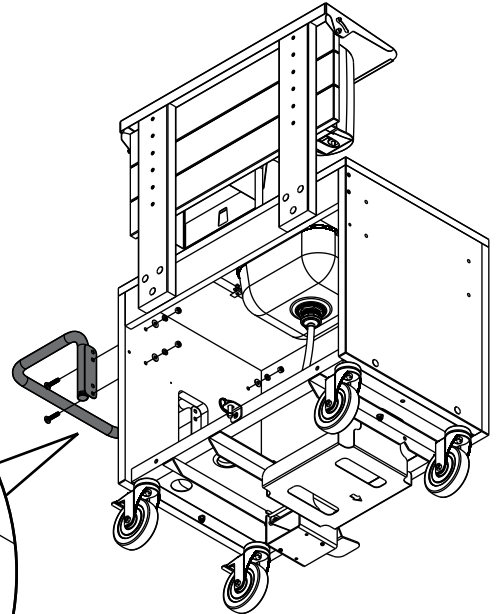

Mounting Plate Diagram

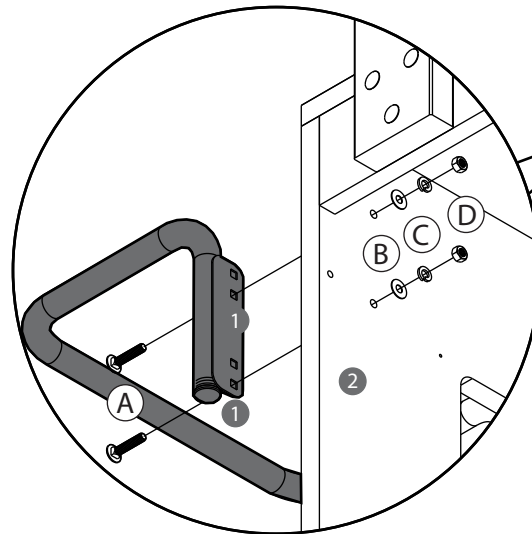
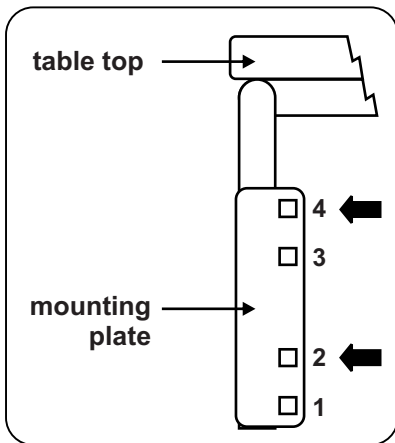

4

Hang Rear Panel on Handle

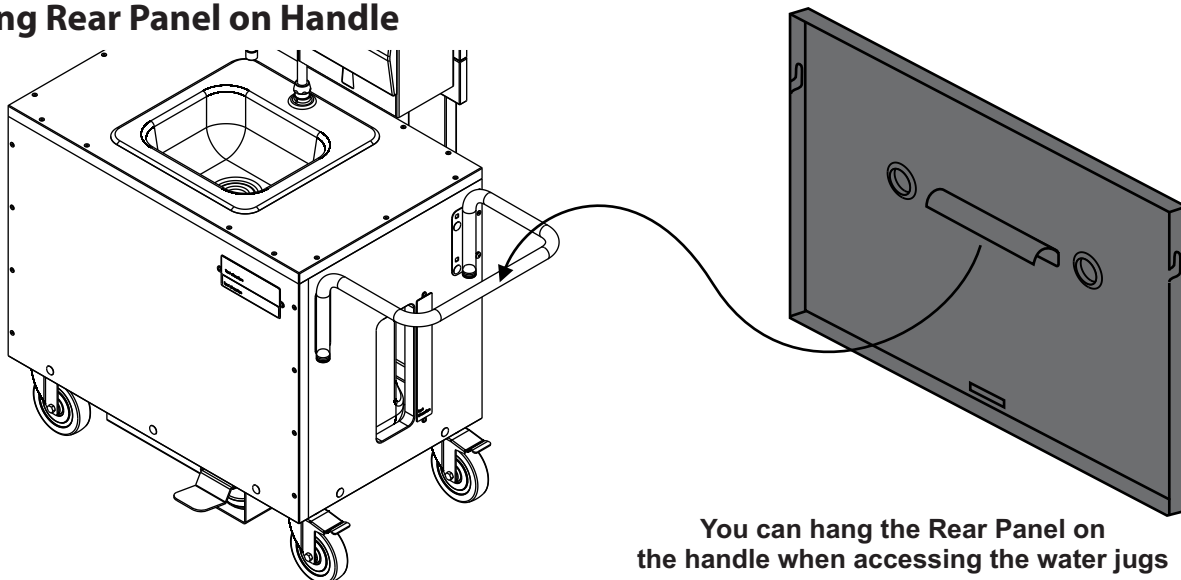

You can hang the Rear Panel on the handle when accessing the water jugs

5.1

Fill Fresh Water Container Disconnect Supply Line & Remove Container

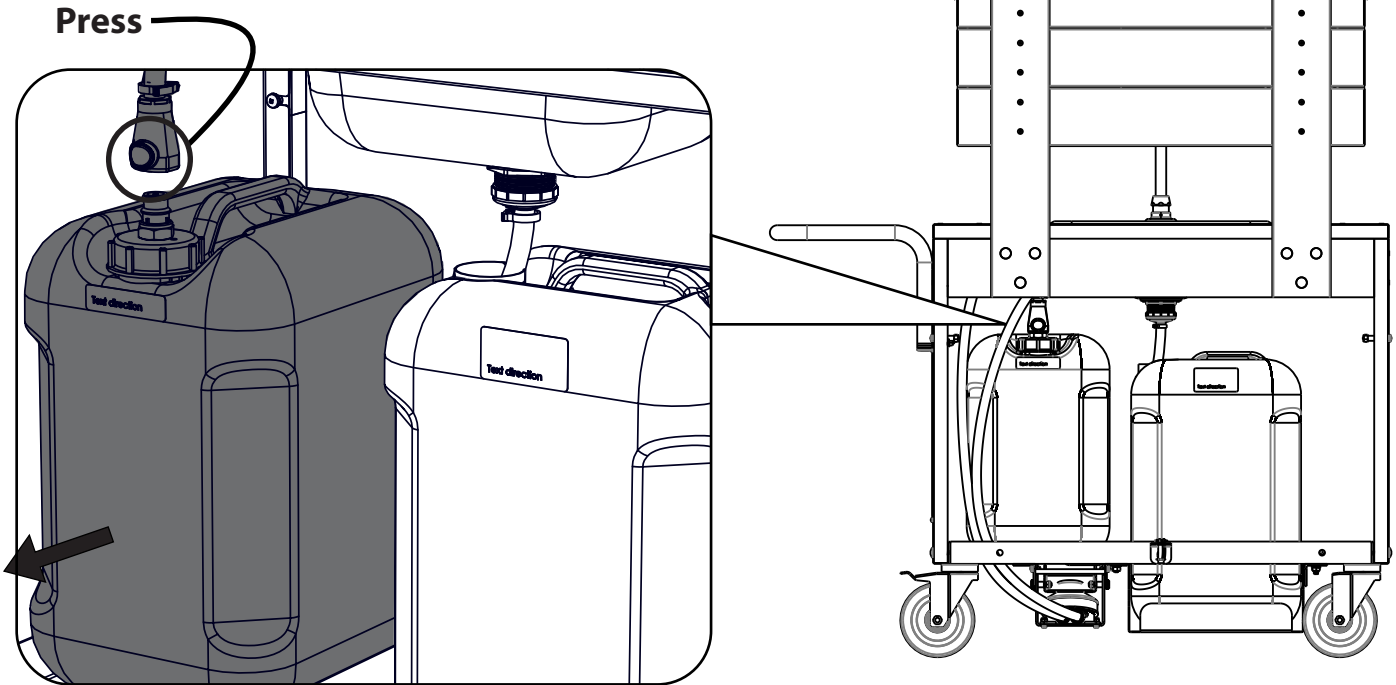

5.2

★ Recommend filling Water Containers with warm tap water

Fill Fresh Water Container

1 Unscrew Siphon & Fill With Water

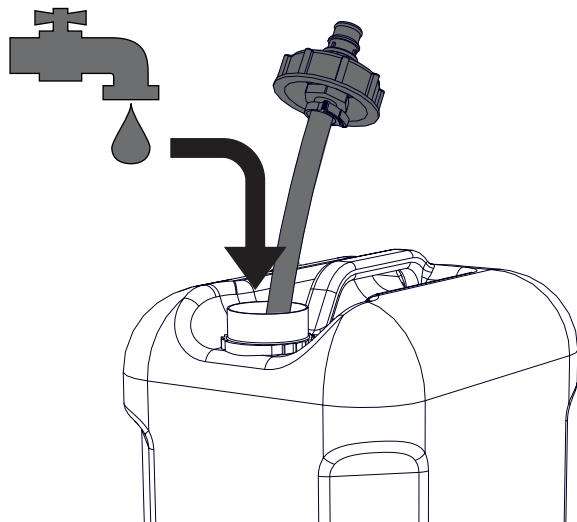

2 Screw Siphon Back Onto Container

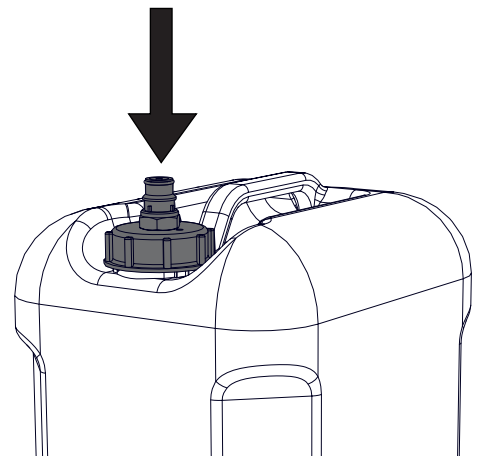

5.3

Click

**Fill Fresh Water Container
Put Container Back & Reconnect Supply Line**

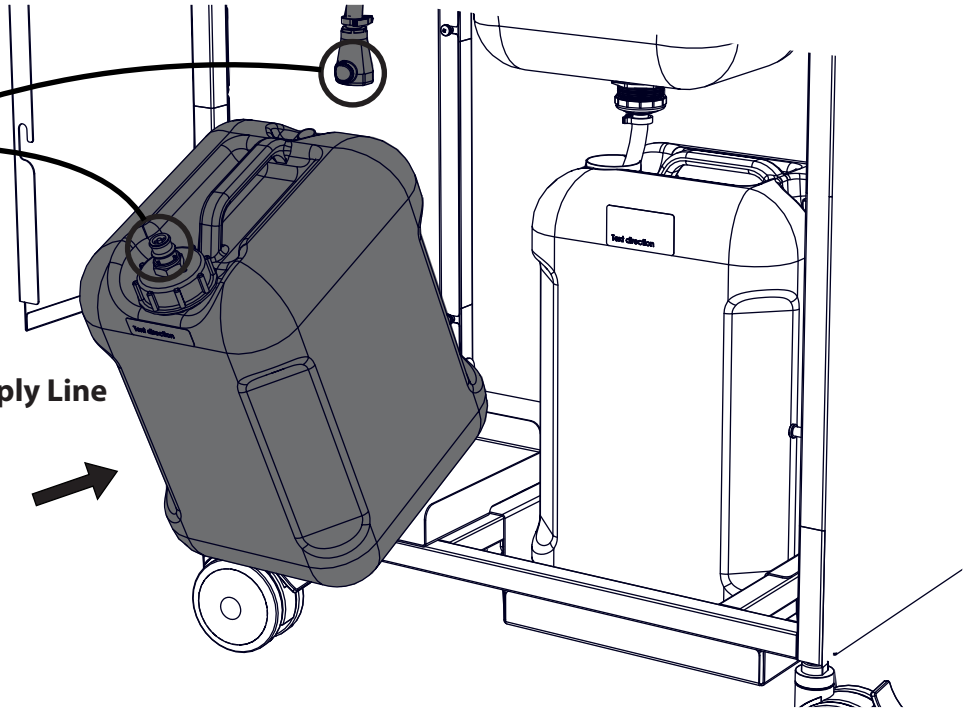

6

Attach Rear Panel

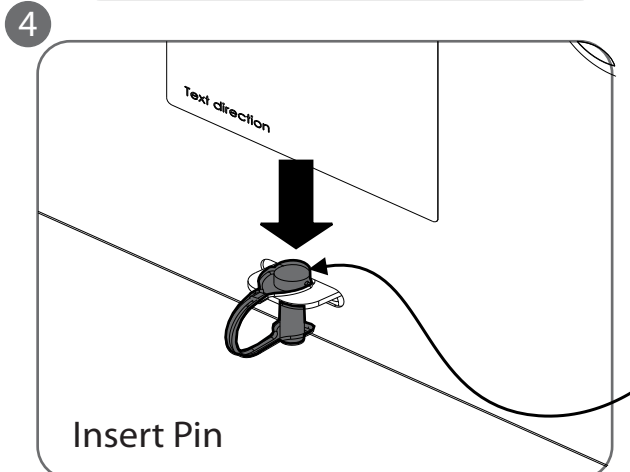
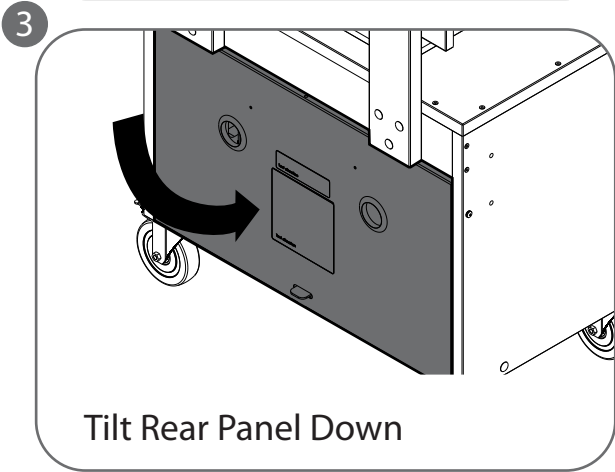
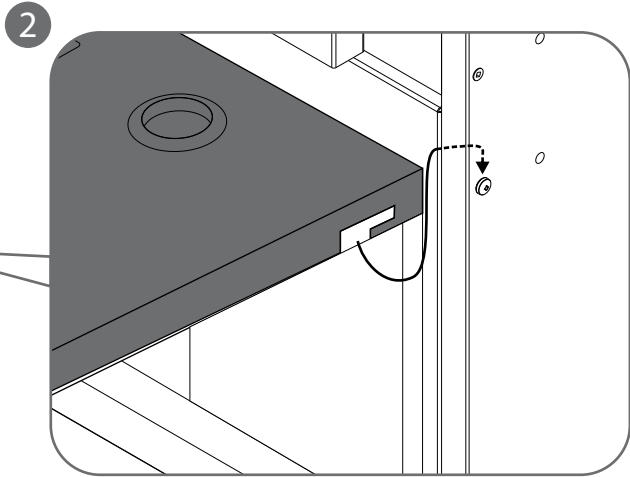
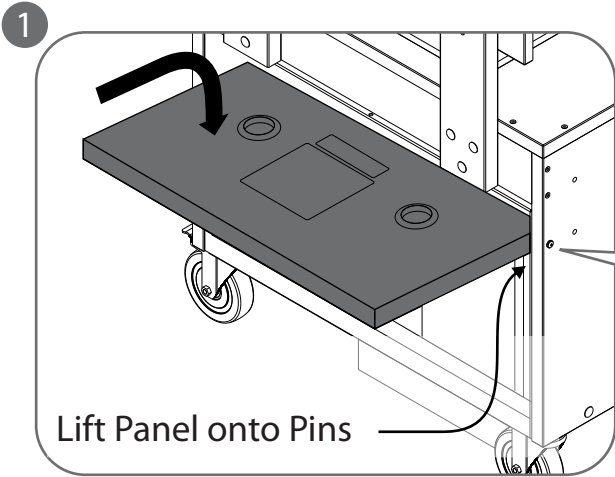

You can swap the pin for a padlock (not included) to lock the rear panel

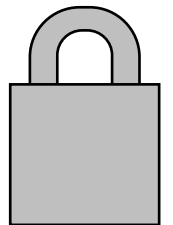

Setting Up Hands-free Soap Dispenser (For SNK500/SNK600 only)

1 Insert key

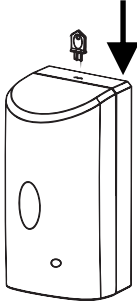

2 Open cover

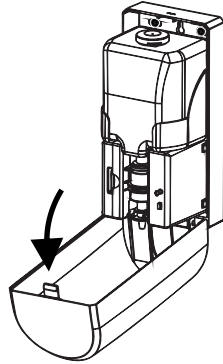

3 Remove battery cradle

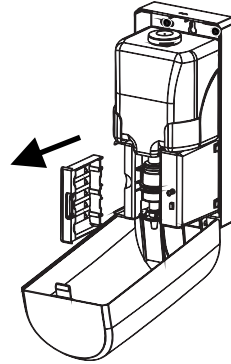

4 Insert 6 x AA batteries (not included)

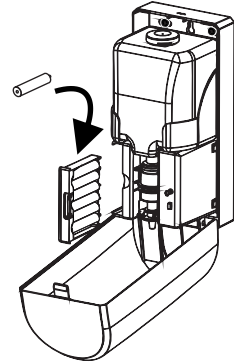

5 Remove cap

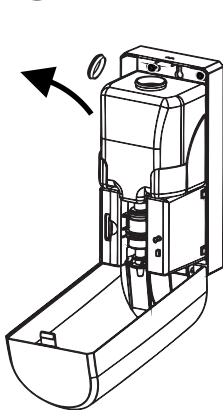

6 Fill with soap

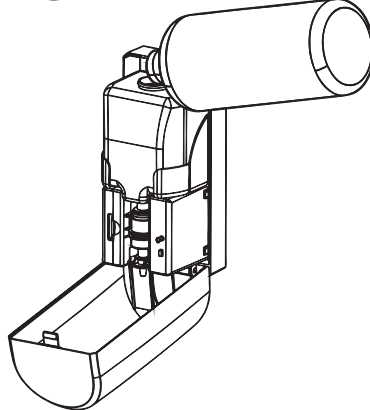

7 Install cap

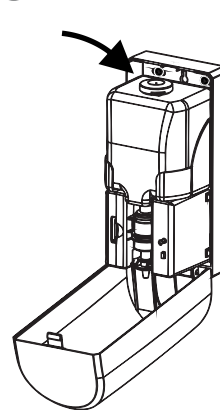

8 Close cover

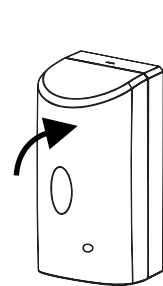

First Hand Wash

Using Foot Pump

- 1 Step on foot pump to dispense water
- 2 The first time pump is used, it will have to be primed, so it will require around 8-10 steps before water comes out



Unit provides between 50-60 hand washes when full

We recommend 6 pumps per hand washing

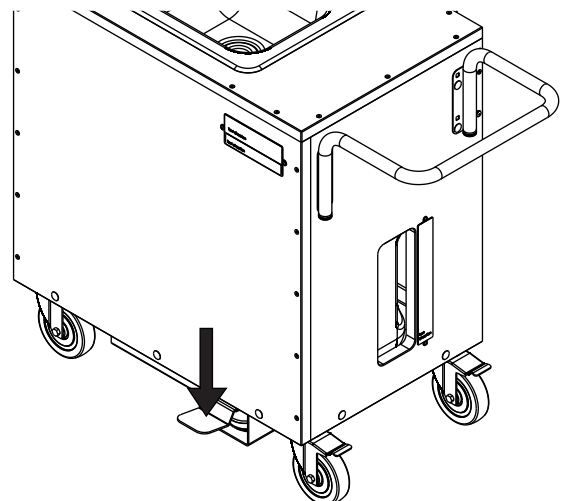

9.1

! Dispose of water according to local laws

Draining Waste Water

Remove Rear Panel, Pull Out Drain Tube & Empty Container

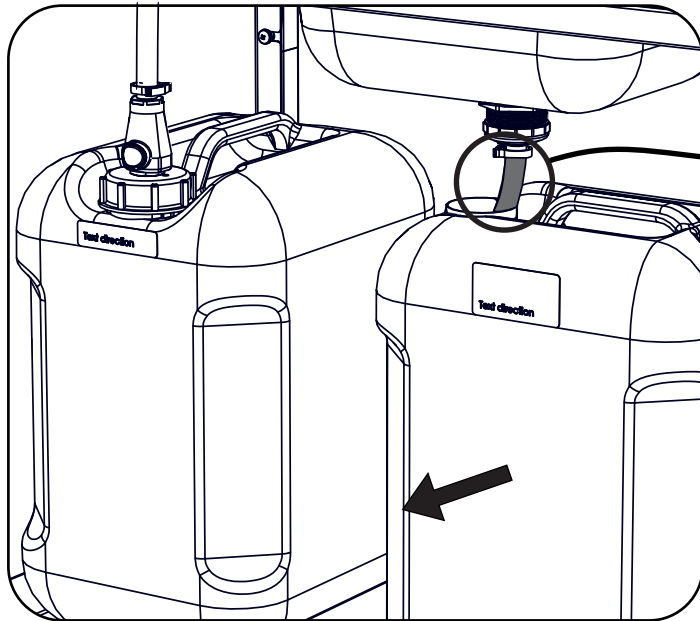
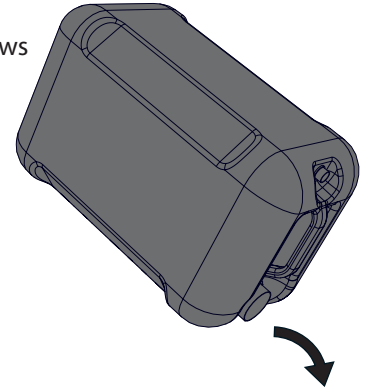

Pull out

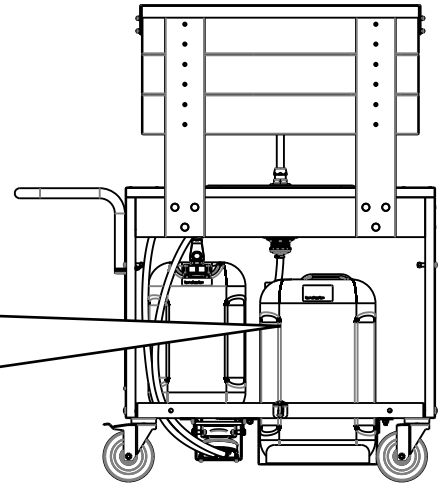

9.2

Draining Waste Water

Put Container Back, Insert Drain Tube & Reattach Rear Panel

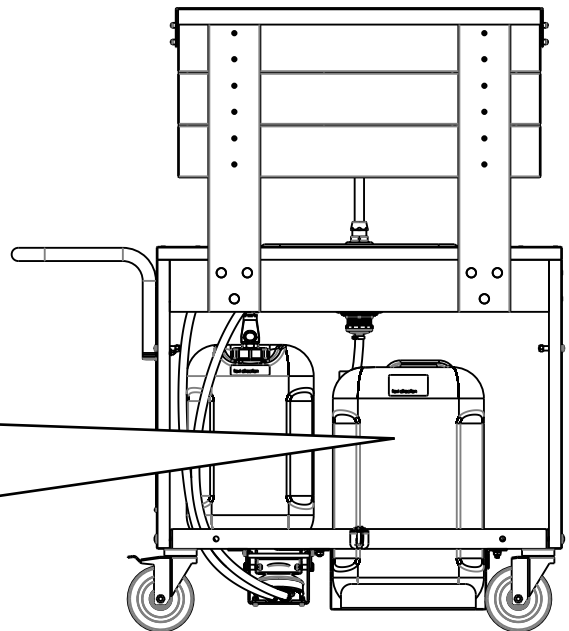
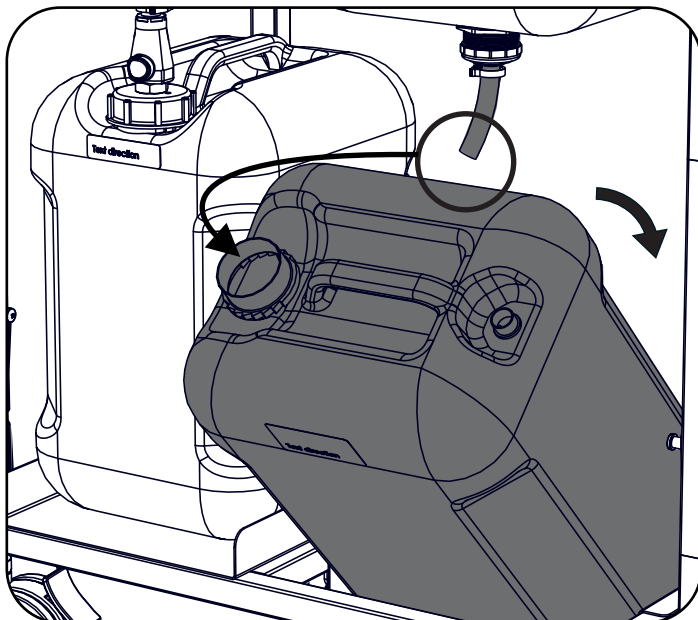

Daily

- Empty & rinse waste water tank
- Check fresh water level
- Wipe down & dry all surfaces
- Mop up any spills around sink

Biweekly

- Clean tanks and lines using Steramine® (available on Amazon, Walmart) or a similar product
- For more information on Steramine® visit www.sanitize.com/products
- Never use bleach to clean sink! It may stain the sink surface and corrode the plumbing inside the unit

Storage

- Never store outside when temperature is below freezing
- Drain all water and clean all surfaces before storing

Troubleshooting/Customer Service

Phone: 1-800-267-8494, Mon - Fri, 8:00am - 4:30pm EST

Email: info@copernicused.com

CDC - Handwashing Training & Education

For additional information and resources on handwashing visit the CDC website below:

www.cdc.gov/handwashing/training-education.html

Issue	Reason	Solution
No water flow when stepping on foot pump	Fresh water supply line might be disconnected	Reconnect supply line
	Fresh water tank might be empty	Fill fresh water tank
Water leaking under foot pedal	Ring clamp around rubber housing is loose (see Fig. 1 below)	Tighten ring clamp, clean up any spilled water
Faucet base leaking water	Faucet nut might be loose	Tighten nut at base of faucet
Water leaking under sink	Drain hose might not be inserted into waste water tank	Insert drain hose into waste water tank
	Waste water might be full	Empty waste water according to local laws
There is mold or mildew in tanks or lines	Tanks or lines not cleaned every 2 weeks	Use Steramine® or similar product to clean tanks and lines

Fig. 1

