

mLT-30 Mini Laptop Cart

55315BW	mLT-30 Laptop Cart
55319BW	mLT-30 w/ wire management trays
55318BW	mLT-30 w/ wire management trays & rear locking door

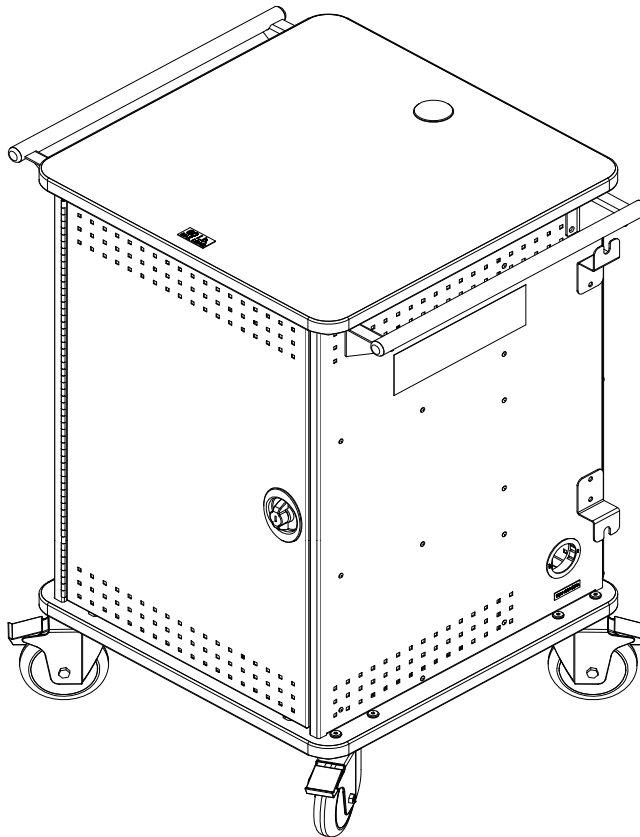

55315BW
mLT-30 Mini Laptop Cart
w/ 5" Balloon Wheels

CAUTION:

Before using this product, read this manual and follow all safety and operating instructions.

IMPORTANT:

Before you begin, please make sure all parts and proper quantities are included. Any parts damaged during shipment must be reported within 15 days of receipt. To report information regarding damages or if you have any questions, please call 1-800-235-1262.

To purchase parts or accessories, please contact us at
www.spectrumfurniture.com
1-800-235-1262

Thank you for choosing Spectrum products!

Touchboards

205 Westwood Ave, Long Branch, NJ 07740
Phone: 866-94 BOARDS (26273) / (732)-222-1511
Fax: (732)-222-7088 | E-mail: sales@touchboards.com





Safety



Read this owners manual before assembly or operation
Do not allow children to move cart
Move slowly and carefully when mobile

Hardware package contents



(4) 0105648
Cord Wrap Bracket



(14) 052605
1/4-20 x 15mm JC Bolt



(6) 0103920
1/4-20 x 1/2"
Thumbscrew



(100) 0102376
11" Zip Tie



(1) 025039
4mm Hex Wrench

Tools Required



4mm Hex Wrench
(included)



Phillips Screwdriver

Assembly / Setup

1. Handle Installation

- Attach handle to the side panel with (4) 1/4-20 x 15mm JC Bolts, but do not tighten completely. **Figure 1.**
- Install two more 1/4-20 x 15mm JC bolts through the handle and into the worksurface as shown.
- Tighten all screws securely.
- Repeat this procedure for the second handle on the opposite side.

Note: Handles must be installed before cord management brackets.

Tools Required:



4mm Hex Wrench

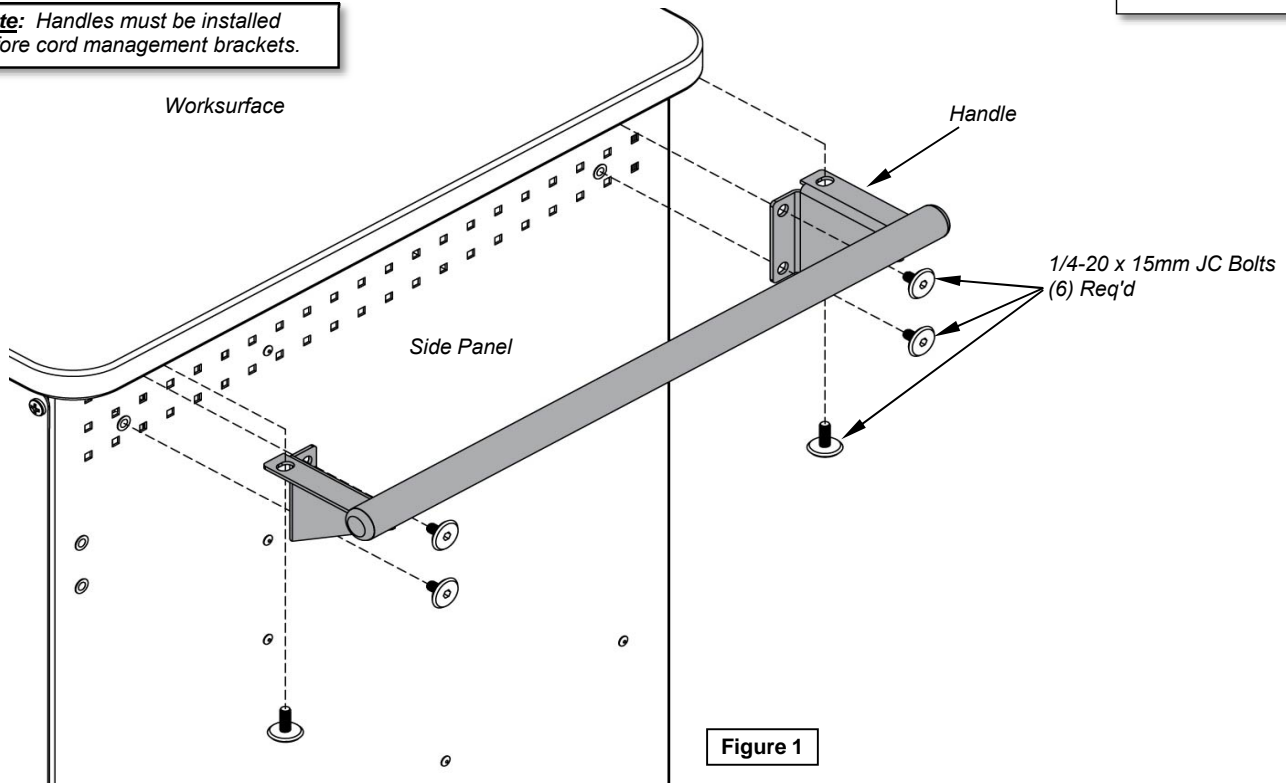

2. Cord Management Bracket Installation

- Attach the cord management brackets to the side panels (left and right-side) with 1/4-20 x 15mm JC bolts as shown in **Figure 2A** and tighten securely. Be sure the brackets are facing away from each other as shown.
- Route each power cord through each lower side panel grommet as shown in **Figure 2B**.
- Wrap excess cord around the brackets as necessary. (See cord management section for further information.)

Tools Required:



4mm Hex Wrench

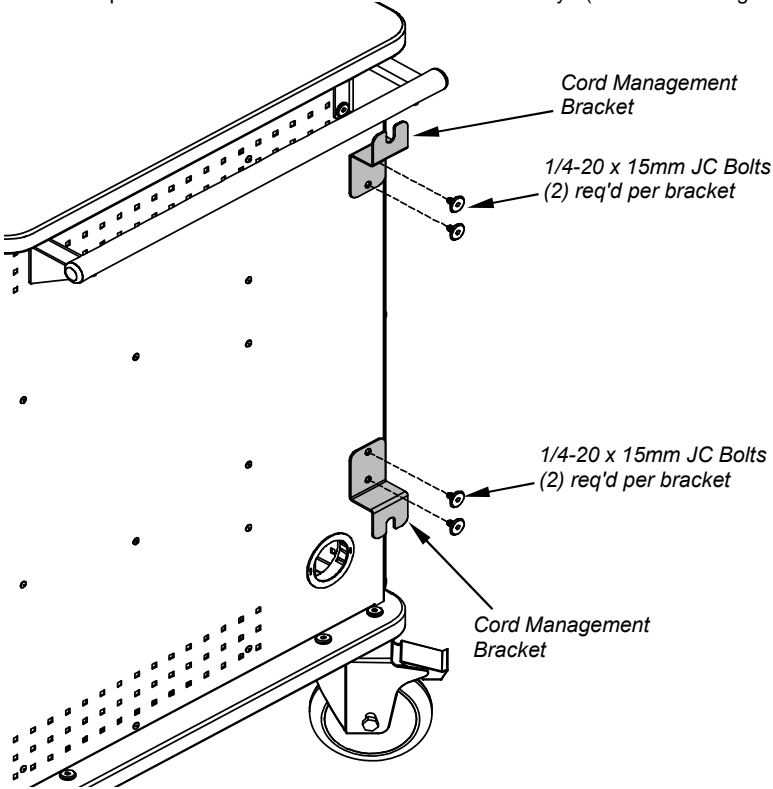

Figure 2A

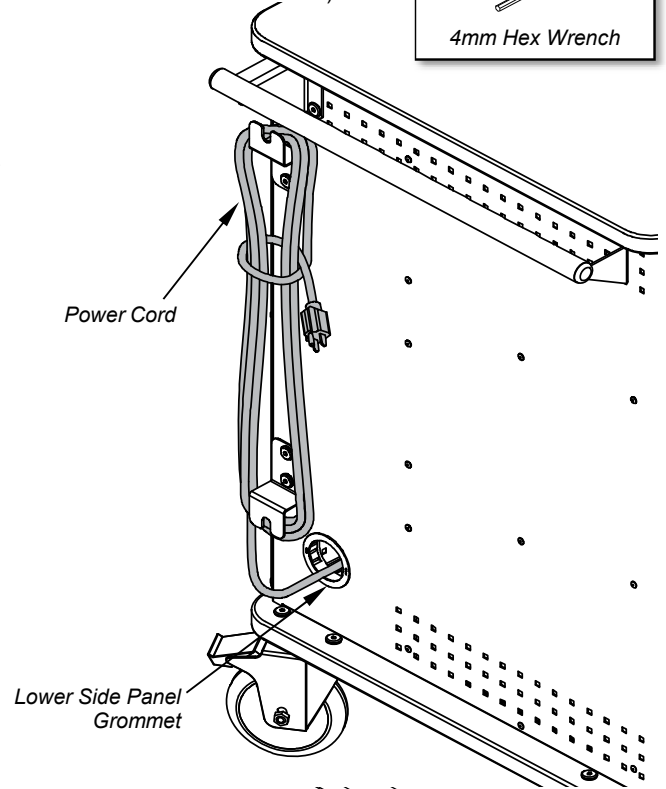

Figure 2B

3. Rear Panel Removal

- The mLT-30 comes with the rear panel installed with (6) 1/4-20 x 5/8" PHM screws. To remove the panel, remove the screws with a Phillips screwdriver. **Figure 3**.
- For quicker access, the screws can be replaced with the (6) included 1/4-20 thumbscrews.

Note: Keep thumbscrews tightened securely at all times.

Tools Required:



Phillips Screwdriver

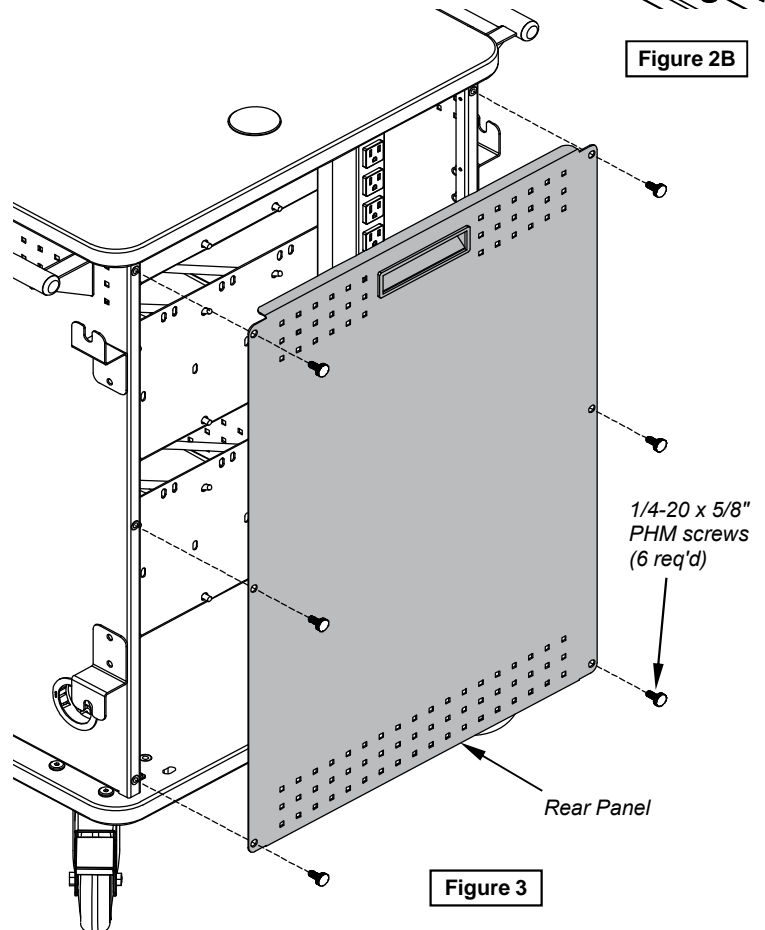
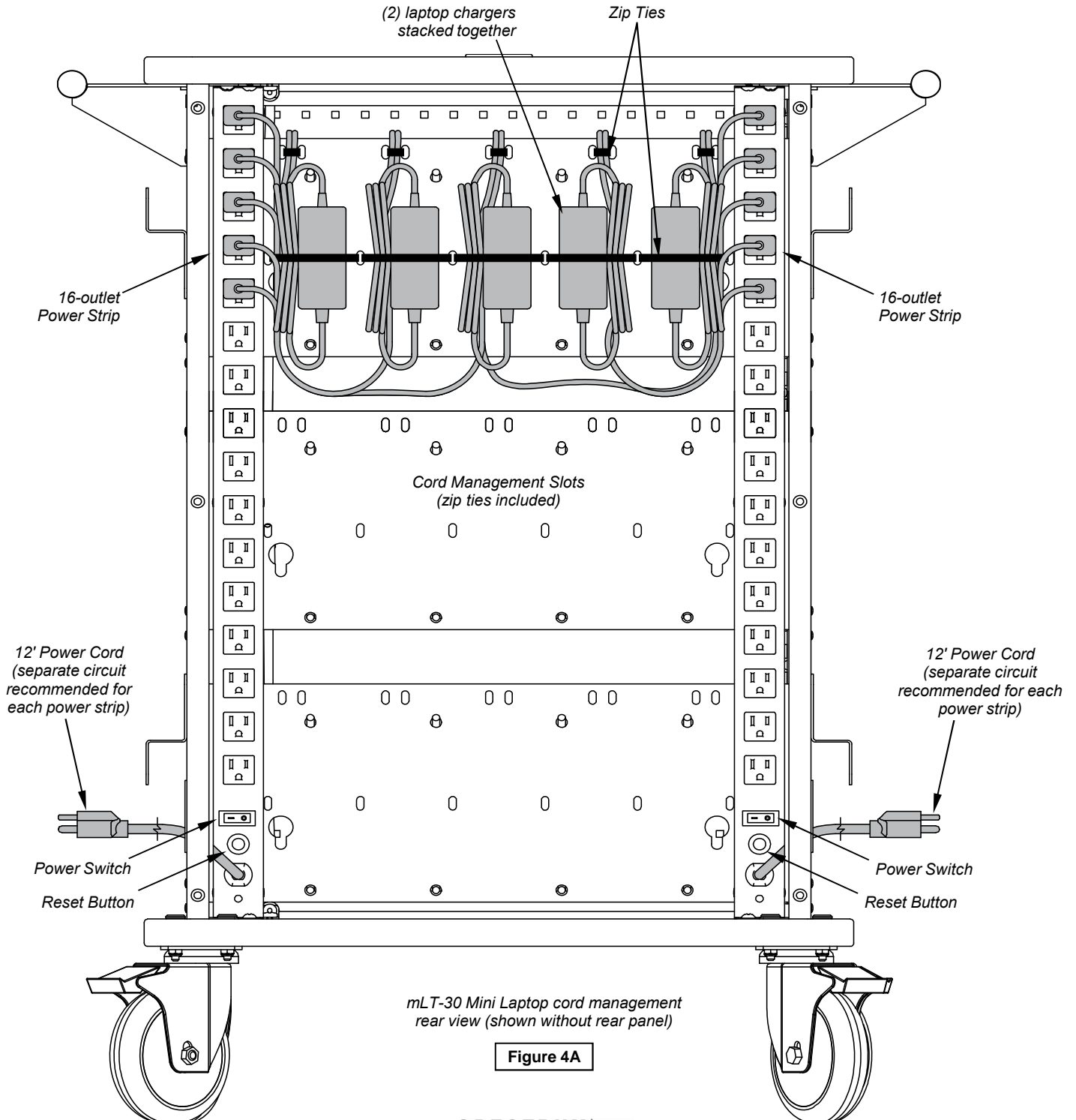
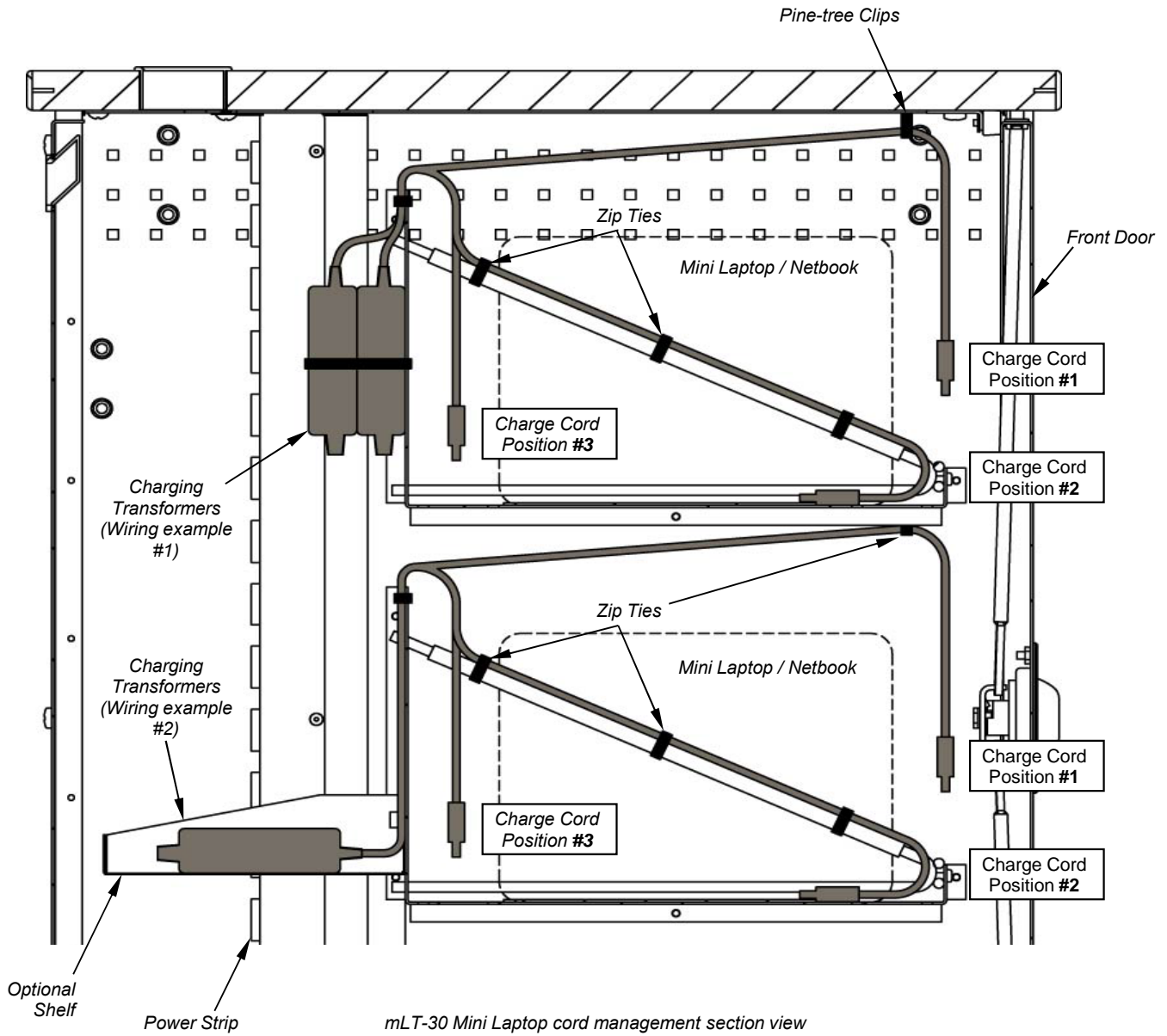

Figure 3

4. Cord Management & Setup

- Remove the rear panel (or open rear door.) Make sure all power cords are unplugged.
- To wire multiple laptop chargers in a row, stack two chargers together along with the necessary bundled charge cords, and attach to the cart using zip ties and the cord management slots shown in **Figure 4A**.
- Charge cords can be routed to the laptops several different ways depending where the charge jacks are located on your particular laptops.** Use zip ties and the cord management slots to route and anchor the laptop charge cords to the cart. Cords can be anchored with the included zip ties as shown. **Figure 4B**. Pine-tree clips are also installed under the worksurface for securing charge cords. **Figure 4B & 4C**.
- With the power strip switches in the 'OFF' position, plug the transformers into the power strips, and the transformers into the laptops.
- When plugging the power strips into wall outlets, be sure a separate circuit is used for each power strip.
- When all power strips and laptops are plugged in, flip the power switches to the 'ON' position.





mLT-30 Mini Laptop cord management section view

Figure 4B

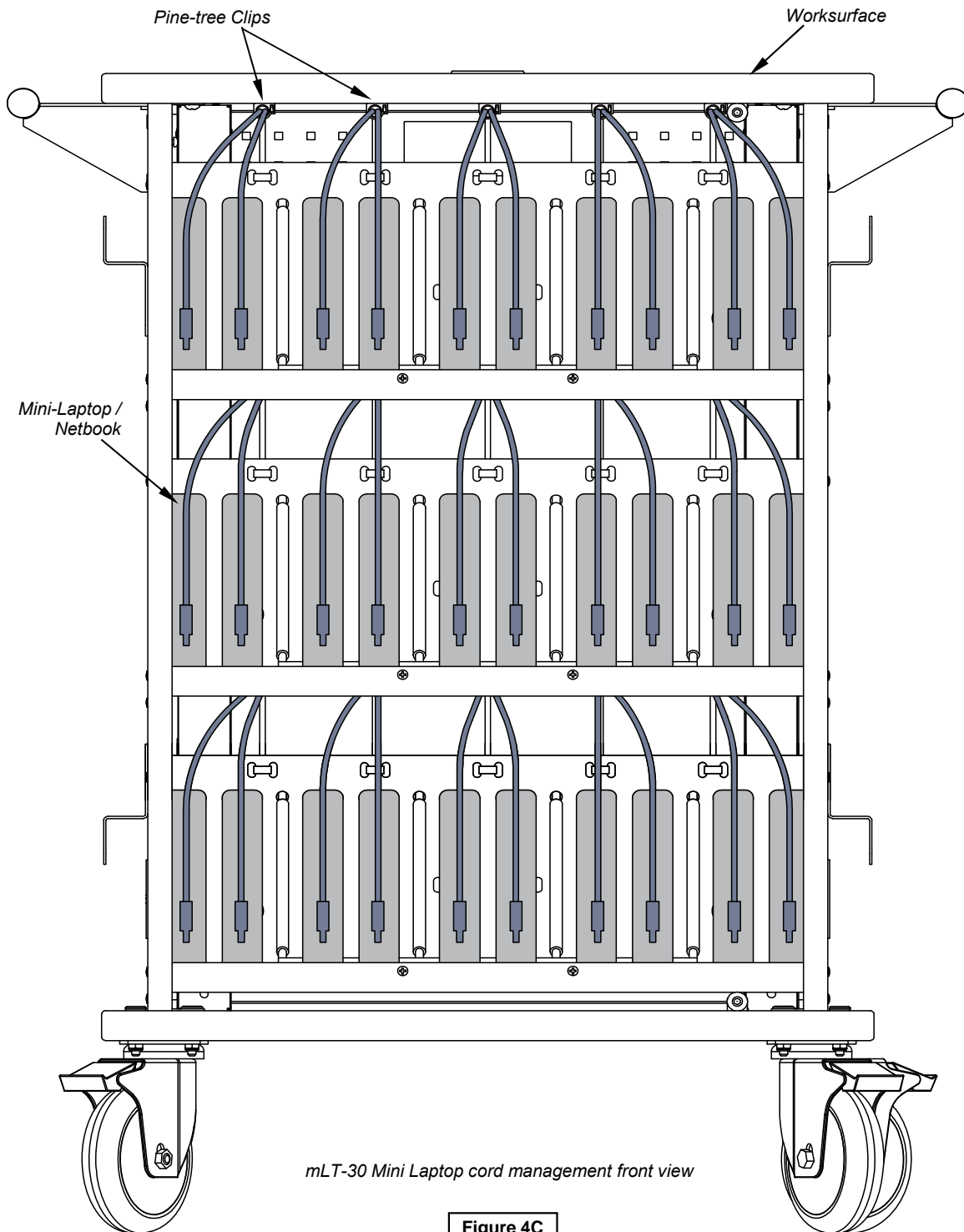



Figure 4C

CAUTION

The mLT-30 Mini Laptop Cart features two separate 16-outlet charging circuits on separate cords. Some laptop notebook computers may draw more than 1/2 amp when fully discharged. If that is the case, plugging the two power cords into separate 15-amp electrical outlets will prevent an electrical overload which may trip a circuit breaker. Please consult the owners manual of your specific laptop computer for further information.

mLT-30 Power Cord Management (without optional timer or cord reel)

- A. Switch off both power strips.
- B. Route the power strip cords as shown. **Figure 5.** Use the cord management brackets for excess cords.
- C. When plugging the power strips into wall outlets, be sure a separate circuit is used for each power strip.
- D. When all power strips and laptops are plugged in, flip the switch on each power strip to the 'ON' position.

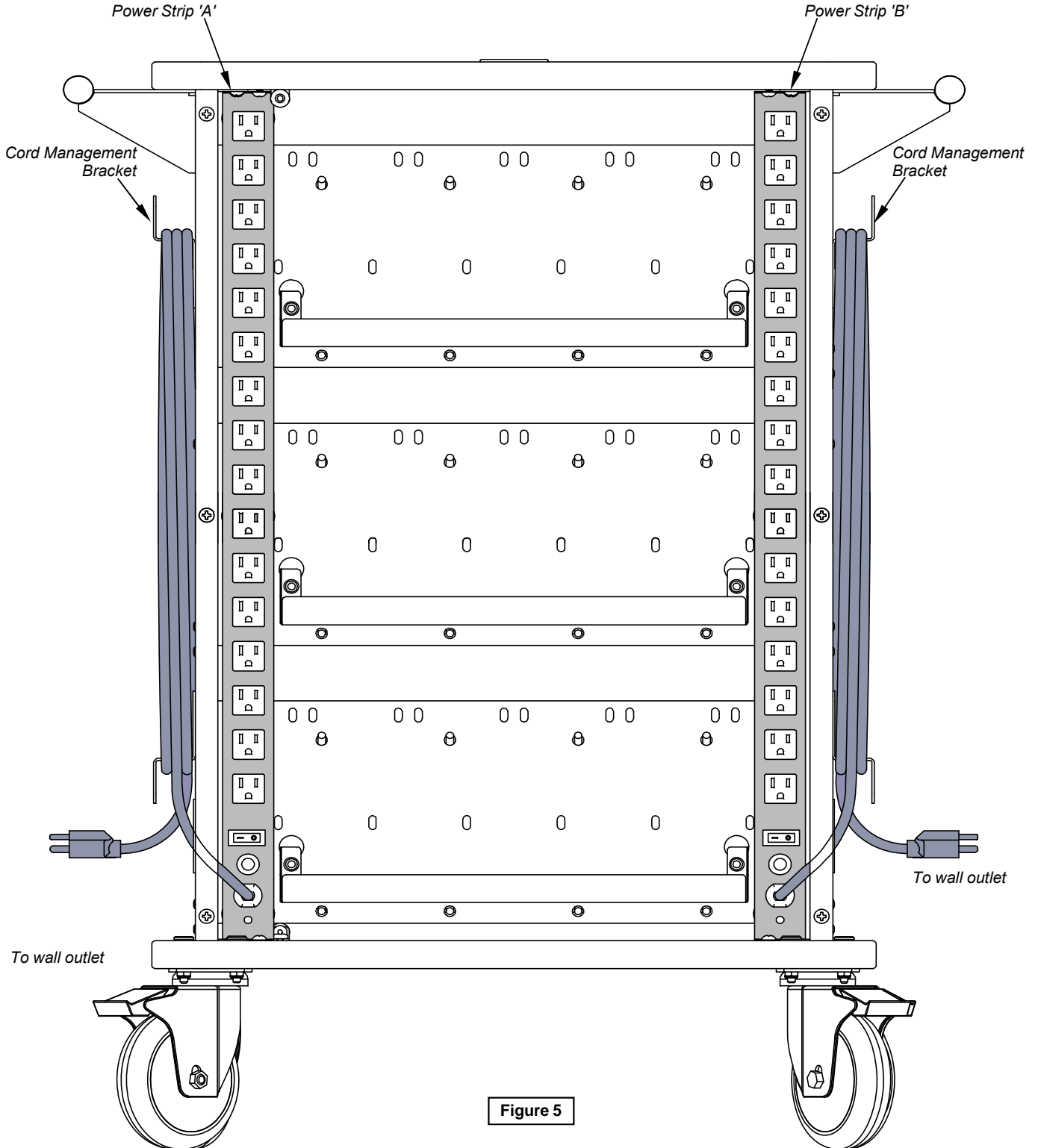
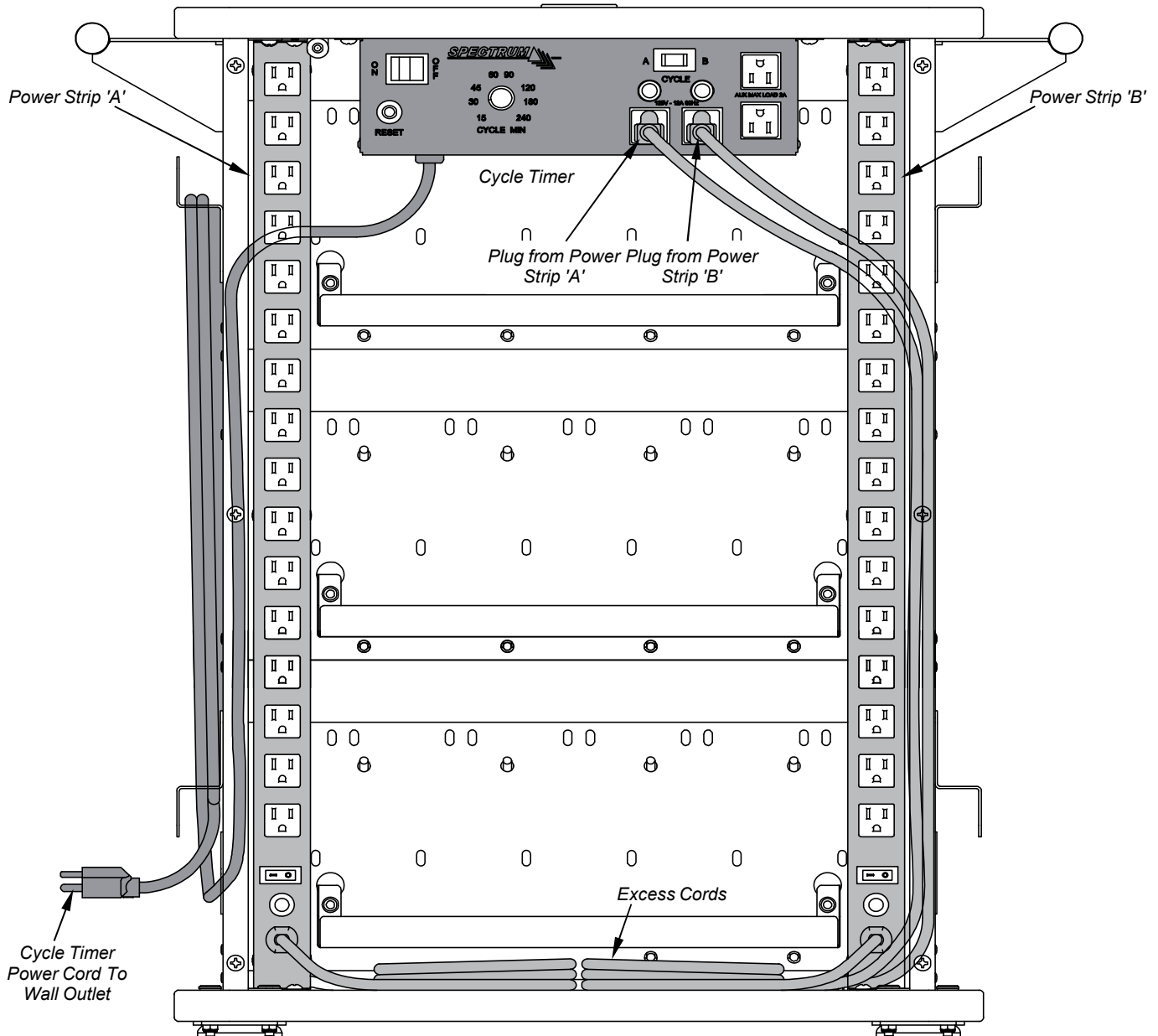

Figure 5

mLT-30 Power Cord Management (with optional timer)

- Switch both power strips and the cycle timer off.
- Route the power strip cords as shown and plug one in to the 'A' side outlet, and one into the 'B' side outlet on the timer. **Figure 6.** (routing these cords behind the power strips will provide easier access to the outlets.)
- Plug the cycle timer power cord into wall outlet.



mLT-30 power cord management rear view
(shown without rear panel)

Figure 6

Moving the Cart

- Before moving the unit, unplug all power cords and wrap around the cord management brackets.
- Be sure the casters are in the unlocked position and the front door is closed.
- Move the cart using the handle. After moving, lock the casters.

<p>WARNING ATTENTION</p>				
<p>CAN TIP OVER RESULTING IN RISK OF INJURY. DO NOT ALLOW CHILDREN UNDER 16 TO MOVE CART. MOVE CART SLOWLY.</p> <p>PEUT BASCULER, ENTRAINANT UN RISQUE DE BLESSURE, NE LAISSEZ PAS LES ENFANTS DE MOINS DE 16 POUR DEPLACER PANIER. DEPLACER PANIER LENTEMENT</p>	<p>ONLY ADULTS SHOULD MOVE THIS UNIT</p> <p>SEULS LES ADULTES DEVRAIENT PASSER CET APPAREIL</p>	<p>APPLY MOVING FORCE ON NARROW DIMENSION</p> <p>APPLIQUER UNE FORCE EN MOUVEMENT SUR LA DIMENSION</p>	<p>NEVER APPLY FORCE AT TOP ALWAYS PUSH NEAR MIDDLE</p> <p>JAMAIS EMPLOYER LA FORCE EN HAUT TOUJOURS POUSSER PRES DU MILIEU</p>	<p>PUSH, DO NOT PULL</p> <p>POUSSER, NE TIREZ PAS</p>

Value Cycle Timer Operation

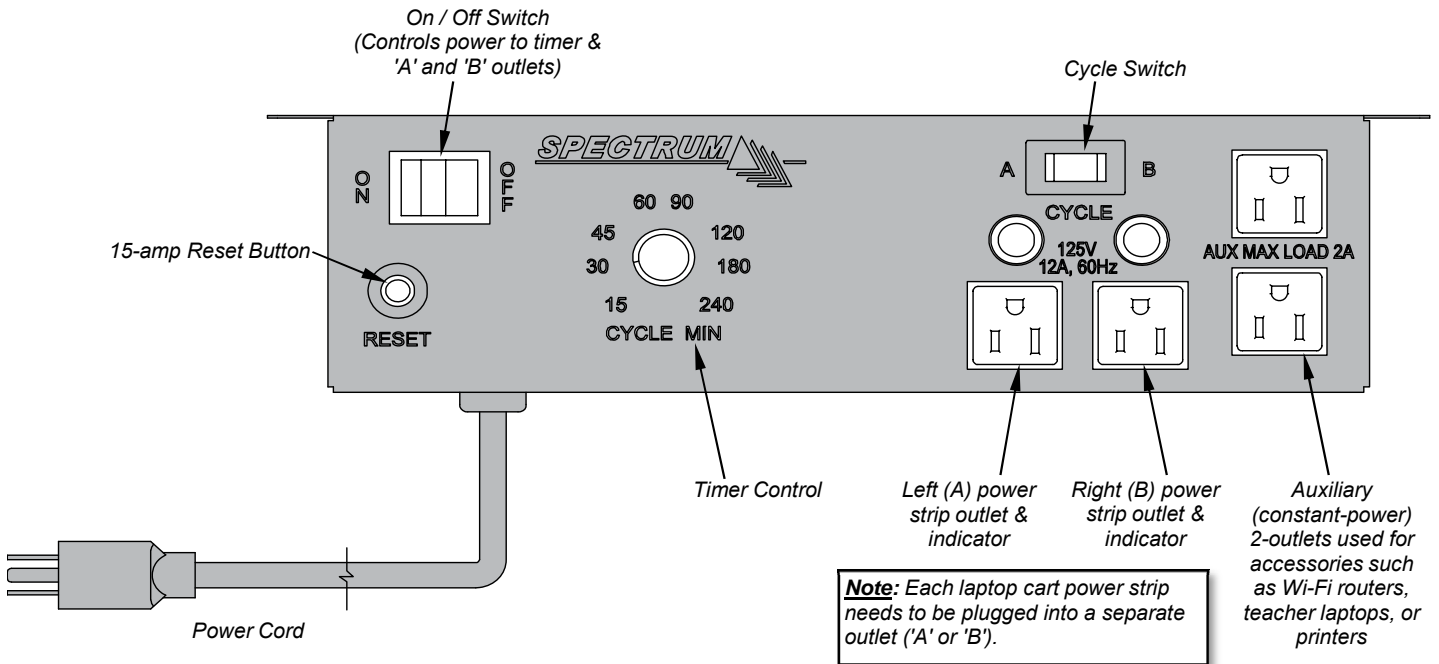

Using Timer:

The timer prevents overload by alternating power between both power strips in the cart, providing charging to multiple laptops during the day. The power strips plug into the outlets labeled 'A' or 'B'.

The timer control can be adjusted between 15-240 minutes. This is the number of minutes a power strip will be "hot" before the timer switches to the other power strip. 15 minutes can be used as the default setting, but the time setting will depend on the laptop size, battery capacity, frequency of laptop use, and the time available for charging between uses. Lower minute settings should be used if the laptops are being used more frequently.

- To cycle charge both 'A' and 'B' sides, keep the cycle switch in the middle 'Cycle' position, then set the timer control to the desired cycling increment. After the Side 'A' time expires, the timer will activate Side "B" for the same period of time and will continue to cycle until the On/Off switch is set to the "OFF" position.
- To manually-override the timer function, and charge side 'A' only, switch the cycle switch from the middle to the 'A' position.
- To manually-override the timer function, and charge side 'B' only, switch the cycle switch from the middle to the 'B' position.

Specifications:

- 12-amp, 120 volt, 60Hz
- 15-240 minute timer
- 20' 14 AWG power cord

⚠ CAUTION ⚠

- Do not use the auxiliary outlets to charge multiple laptops (use the 'A' and 'B' outlets only.) **Auxiliary outlets are for peripheral use only.**
- Total equipment load not to exceed 12-amps per power strip.
- For indoor use only. Do not install or store the unit where it will be exposed to weather. Keep unit dry.
- For added safety, plug the timer into a grounded three-prong receptacle controlled by a GFI (Ground Fault Interrupter) circuit breaker.

mLT-30 Options

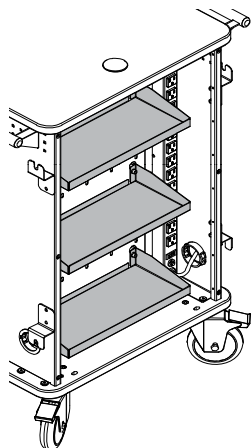
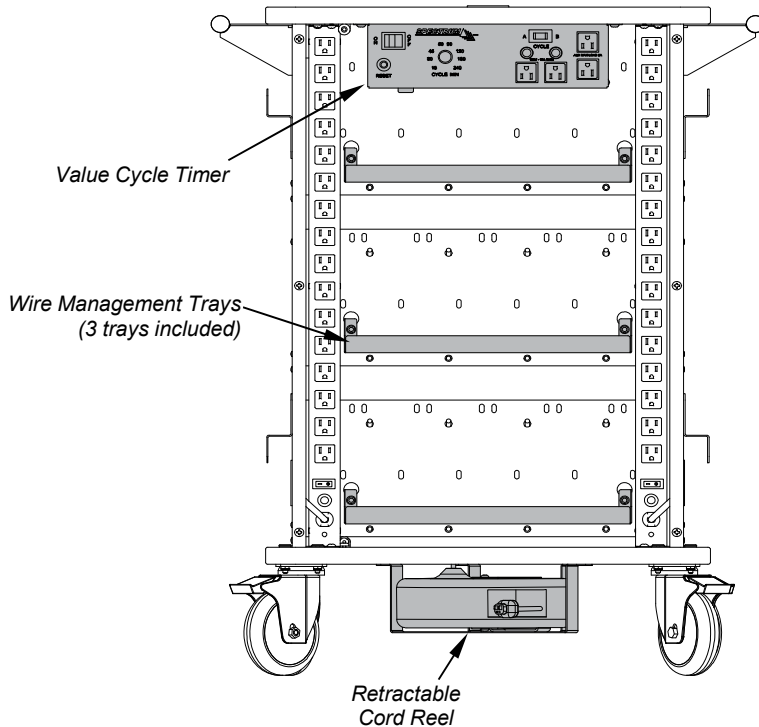

Wire Management Trays
16"W x 6"D x 2"H
(set of 3 trays holds charging
transformers and cords)
shipping weight: 7 lbs
55316

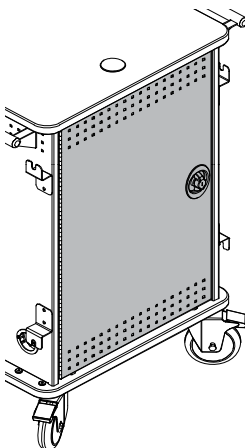

Rear Double-Bolt Locking Door
19 1/4"W x 3 1/4"D x 30"H
(replaces rear panel)
shipping weight: 13 lbs
55317



Velcro® Strap Kit
(16) 3/4" x 12", and (32) 3/4" x 5"
Velcro® Straps
95004



Replacement Key Set
55142

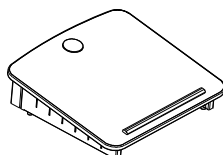

Lectern Riser
18"W x 17 13/16"D
95002

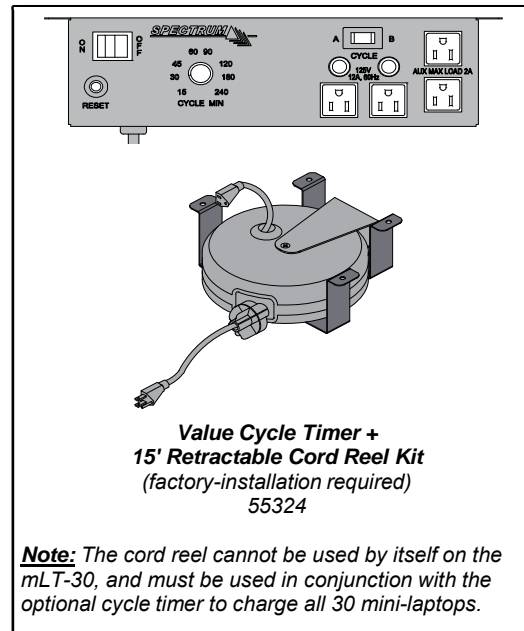

**Value Cycle Timer +
15' Retractable Cord Reel Kit**
(factory-installation required)
55324

Note: The cord reel cannot be used by itself on the mLT-30, and must be used in conjunction with the optional cycle timer to charge all 30 mini-laptops.

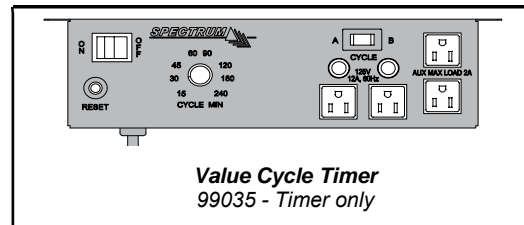

Value Cycle Timer
99035 - Timer only



Custom-Cut Logo
(Typical logo location on
rear panel or door)
55141

Technical Specs

Construction

- The worksurface and base panel is constructed from 1¹/₁₆" NAUF (No Added Urea Formaldehyde) composite board with .030 high-pressure laminate on one face, and a balancing phenolic backer on the opposing face
- 16-gauge side panels, shelves, and front door
- All metal components are finished with a scratch-resistant powder coat epoxy
- Worksurface edges are covered with 3mm vinyl
- Each Mini Laptop Cart is factory-assembled, packaged, and shipped on its own skid (Handle, and cord management brackets to be installed by customer)

Capacity

- Overall dimensions: (See dimensioned drawings)
- Mini Laptop capacity: 30 units
- 15 storage slots - 4"W x 12¹/₄"D x 10"H (each slot holds 2 mini laptops)
- Electrical: The cart has two 16-outlet (125V) power strips, each containing a 15-amp breaker, on/off switch and a 12' nominal 14 AWG, 3-wire power cord. Outlets are accessible from the back of the unit via a removable panel held in place with 6 Phillips screws or 6 easily removable thumbscrews (both included.) A separate wall circuit is recommended for each power strip.
- Meets or exceeds all ANSI-BIFMA test standards
- Features and specifications subject to change without notice
- **Unit weight (nominal):** 139 lbs
- **Shipping weight (nominal):** 167 lbs

55315BW
mLT-30 Mini Laptop Cart
w/ balloon wheels

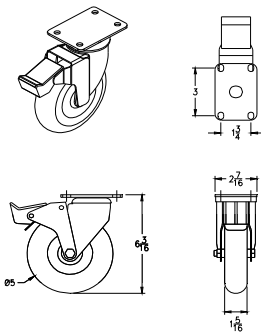
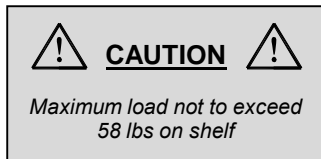
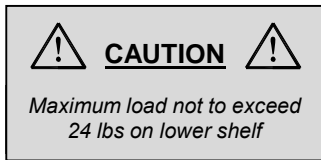
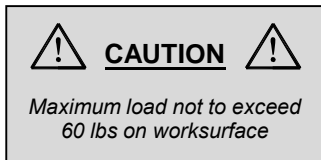

5" balloon wheels

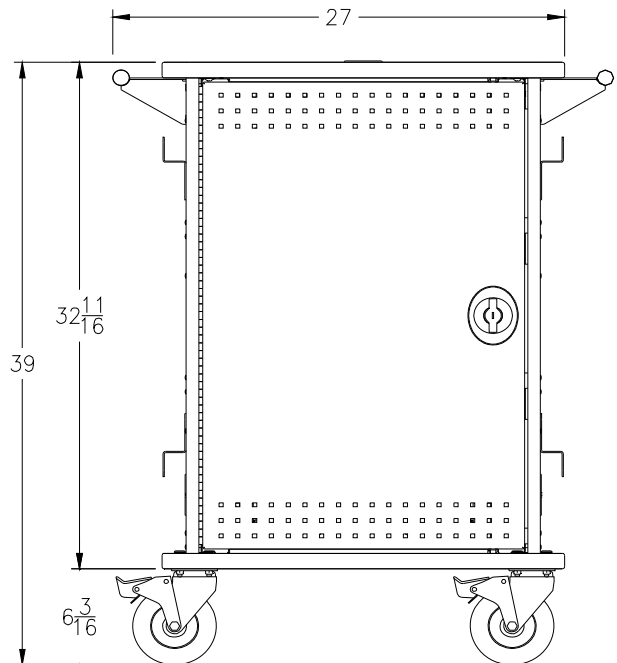
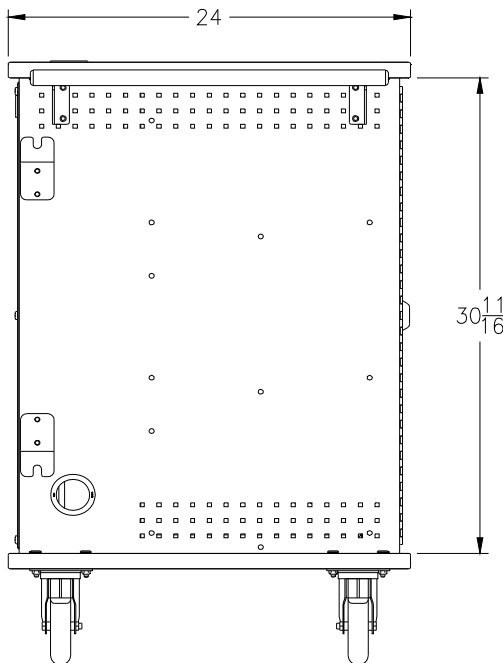
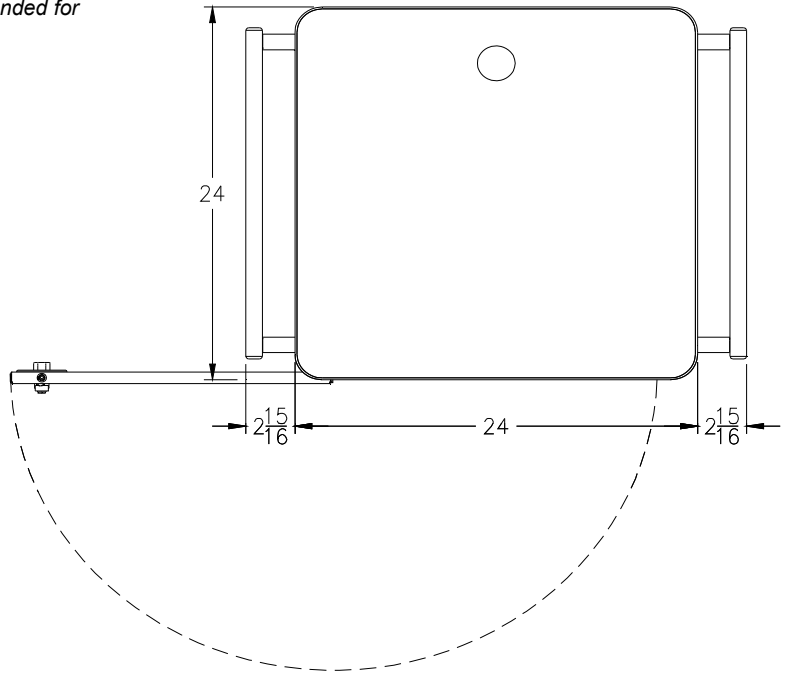

Warranty

WE WILL MAKE IT RIGHT FOR YOU!

We guarantee all Spectrum products to be free of all defects in materials and workmanship, for the original owner, for a period of **ten years**. Any item deemed defective by Spectrum or the original manufacturer, under normal use conditions, will be repaired or replaced at Spectrum's discretion. This warranty applies to all products manufactured and distributed by Spectrum except the products listed below.

DESIGNED FOR INDOOR USE ONLY - Spectrum's products have been designed and constructed for indoor use only. Moving or using outdoors, or on excessively rough surfaces, may cause damage to the products and may void the warranty. If an outdoor application is desired please contact us to discuss potential custom design solutions.

Spectrum is committed to provide complete customer satisfaction. Each of our products are manufactured from the best materials available and each product is stringently monitored throughout the production process through our P.A.C.E. program (Product Assurance to meet Customer Expectations).

Our Customer Service Help Line 1-800-235-1262 is ready to provide immediate attention to any questions, comments or concerns. We are available to answer your calls Monday through Friday from 7 am to 5 pm CST. In addition your product comments or concerns are welcome via e-mail at: spectrum@spectrumfurniture.com.

Items that have a varying warranty include, but are not limited to, the following:

- Adjustable Crank/Electric Desk Legs (1 yr)
- Flat Panel Desk Gas Cylinders (1 yr)
- Adjustable Height Chair Parts – including frames, gas cylinders, wood and plastic parts, and control handles (7 yrs)
- Adjustable Height Chair Parts Casters (2 yrs)
- Adjustable Height Chair Upholstery - In-Stock Upholstery (2 yrs)
- Adjustable Height Chair Upholstery - Graded-In Fabrics and C.O.M (no warranty)
- Height Adjustable Columns and Lifts (1 yr)
- General Use Casters (1 yr)
- Electrical – ECA (1 yr)
- Electrical - Power Strips (1 yr)
- Electrical Surge Suppressors (lifetime)
- Electrical - Retractable Power Cords (1 yr)
- Keyboard/Mouse Trays (1 yr)
- Flat Panel Monitor Arm – General Parts (5 yrs)
- Flat Panel Monitor Arm – Gas Cylinders (2 yrs)
- CRT Monitor Arm (1 yr)

The warranty, as stated above, is effective as of 05/28/2009

Touchboards

205 Westwood Ave, Long Branch, NJ 07740
Phone: 866-94 BOARDS (26273) / (732)-222-1511
Fax: (732)-222-7088 | E-mail: sales@touchboards.com



SCIENTIFIC CERTIFICATION SYSTEMS
SCS-IAQ-02352



SPECTRUM
INDUSTRIES INC.

925 First Avenue, PO Box 400, Chippewa Falls, WI 54729 Ph: 1-800-235-1262 Fax: 1-800-335-0473

E-mail: spectrum@spectrumfurniture.com web: www.spectrumfurniture.com