

# ENGLISH

## User manual



**Table of contents:**

1. SAFETY PRECAUTIONS AND PROCEDURES .....	2
1.1. Preliminary .....	2
1.2. During use .....	3
1.3. After use .....	3
1.4. Measuring (overvoltage) categories definitions .....	3
2. GENERAL DESCRIPTION .....	4
3. PREPARATION FOR USE .....	4
3.1. Initial .....	4
3.2. Supply voltage .....	4
3.3. Calibration .....	4
3.4. Storage .....	4
4. OPERATING INSTRUCTIONS .....	5
4.1. Instrument description .....	5
4.1.1. Front panel description .....	5
4.2. Description of function keys .....	6
4.2.1. HOLD Key .....	6
4.2.2. R (RANGE) Key .....	6
4.2.3. MAX Key .....	6
4.2.4. SEL Key .....	6
4.2.5. Backlight  key (only HT322) .....	6
4.2.6. Auto Power OFF .....	6
4.3. Measurements .....	7
4.3.1. DC Voltage measurement .....	7
4.3.2. AC Voltage measurement .....	8
4.3.3. Resistance measurement .....	9
4.3.4. Diode test and Continuity test .....	10
4.3.5. Temperature measurement (only HT322) .....	11
5. MAINTENANCE .....	12
5.1. General information .....	12
5.2. Battery replacement .....	12
5.3. Cleaning .....	12
5.4. End of life .....	12
6. TECHNICAL SPECIFICATIONS .....	13
6.1. Technical features .....	13
6.1.1. Safety .....	14
6.1.2. General data .....	14
6.2. Environment .....	14
6.2.1. Environmental conditions .....	14
6.3. Accessories .....	14
6.3.1. Standard accessories .....	14
6.3.2. Optional accessories .....	14
7. SERVICE .....	15
7.1. Warranty conditions .....	15
7.2. After-sale service .....	15

## 1. SAFETY PRECAUTIONS AND PROCEDURES

This meter is compliance with safety Standard IEC/EN61010-1 related to electronic measuring instruments. For your own safety and to avoid damaging the instrument follow the procedures described in this instruction manual and read carefully all notes preceded by this symbol .

When taking measurements:

- Avoid doing that in humid or wet places.
- Avoid doing that in rooms where explosive gas, combustible gas, steam or excessive dust is present.
- Keep you insulated from the object under test.
- Do not touch exposed metal parts such as test lead ends, sockets, fixing objects, circuits etc.
- Avoid doing that if you notice anomalous conditions such as breakages, deformations, fractures, leakages of battery liquid, blind display etc.
- Be particularly careful when measuring voltages exceeding 20V to avoid risks of electrical shocks.

The following symbols are used:



CAUTION - refer to the instruction manual - an improper use may damage the instrument or its components.



Danger high voltage: risk of electric shocks.



Double insulated meter.



AC voltage.



DC voltage.

### 1.1. PRELIMINARY

- This instrument has been designed for use in environments of pollution degree 2
- It can be used for **VOLTAGE** measurements on installations of CAT III 1000V or CAT IV 600V
- This instrument is not suitable for AC voltage and current measurements of not sinusoidal signals
- Only the original test leads supplied along with the instrument guarantee compliance with the safety standards in force. They must be in a good conditions and, if necessary, replaced with identical ones
- Do not test nor connect to any circuit exceeding the specified overload protection.
- Do not take measurements under environmental conditions exceeding the limits indicated in § 6.1.1. and § 6.2.1
- Make sure that batteries are correctly installed
- Before connecting the test probes to the installation make sure that the rotary selector is positioned on the right function
- Make sure that LCD and rotary selector indicate the same function

## 1.2. DURING USE

Read the recommendations which follow and the instructions in this manual:



### CAUTION

An improper use may damage the instrument and/or its components or injure the operator.

- When changing the range, first disconnect the test leads from the circuit under test in order to avoid any accident
- When the instrument is connected to measuring circuits never touch any unused terminal
- When measuring resistors do not add any voltage. Although there is a protection circuit, excessive voltage could cause malfunctioning.
- If during measurement the displayed values remain constant check whether the HOLD function is active

## 1.3. AFTER USE

- After using the instrument turn it off.
- If you expect not to use the instrument for a long period remove the battery to avoid leakages of battery liquids which may damage its inner components.

## 1.4. MEASURING (OVERVOLTAGE) CATEGORIES DEFINITIONS

IEC/EN61010-1: Safety requirements for electrical equipment for measurement, control and laboratory use, Part 1: General requirements, gives a definition of measuring category, usually called overvoltage category. § 6.7.4: Measuring circuits:

(OMISSIS)

Circuits are divided into the following measurement categories:

- **Measurement category IV** is for measurements performed at the source of the low-voltage installation.  
*Examples are electricity meters and measurements on primary overcurrent protection devices and ripple control units.*
- **Measurement category III** is for measurements performed in the building installation.  
*Examples are measurements on distribution boards, circuit breakers, wiring, including cables, bus-bars, junction boxes, switches, socket-outlets in the fixed installation, and equipment for industrial use and some other equipment, for example, stationary motors with permanent connection to fixed installation.*
- **Measurement category II** is for measurements performed on circuits directly connected to the low voltage installation..  
*Examples are measurements on household appliances, portable tools and similar equipment.*
- **Measurement category I** is for measurements performed on circuits not directly connected to MAINS.  
*Examples are measurements on circuits not derived from MAINS, and specially protected (internal) MAINS-derived circuits. In the latter case, transient stresses are variable; for that reason, the norm requires that the transient withstand capability of the equipment is made known to the user.*

## 2. GENERAL DESCRIPTION

This meter performs the herewith measurements:

- DC Voltage
- AC sine voltage
- Resistance
- Continuity test
- Diode test
- Temperature with type K probe (only HT322)

All selectable by means of a 6-position rotary selector (including OFF position). Also are available the **HOLD** key to hold the displayed value, the **R** key for manual selection of measure ranges, the **MAX** key for measure of maximum value and **SEL** key for selection between diode test and continuity test and temperature measures in °C or °F (only HT322).

The selected quantity is displayed with indication of measuring unit and active functions.

The instrument disposes of an Auto Power Off function consisting in an automatic switching off 15 minutes after last selector rotation.

## 3. PREPARATION FOR USE

### 3.1. INITIAL

This instrument was checked both mechanically and electrically prior to shipment. All possible cares and precautions were taken to let you receive the instrument in perfect conditions. Notwithstanding we suggest you to check it rapidly (eventual damages may have occurred during transport – if so please contact the local distributor from whom you bought the item).

Make sure that all standard accessories mentioned in § 6.3.1 are included. Should you have to return back the instrument for any reason please follow the instructions mentioned in § 7.

### 3.2. SUPPLY VOLTAGE

The instrument is supplied by 2x1.5V batteries type IEC AAA LR03. When batteries are low, a low battery indication is displayed. To replace/insert batteries please refer to § 5.2.

### 3.3. CALIBRATION

The instrument complies with the technical specifications contained in this manual and such compliance is guaranteed for 1 year. Annual recalibration is recommended.

### 3.4. STORAGE

After a period of storage in extreme environmental conditions exceeding the limits mentioned in § 6.2.1 let the instrument resume normal measuring conditions before using it.

## 4. OPERATING INSTRUCTIONS

### 4.1. INSTRUMENT DESCRIPTION

#### 4.1.1. Front panel description

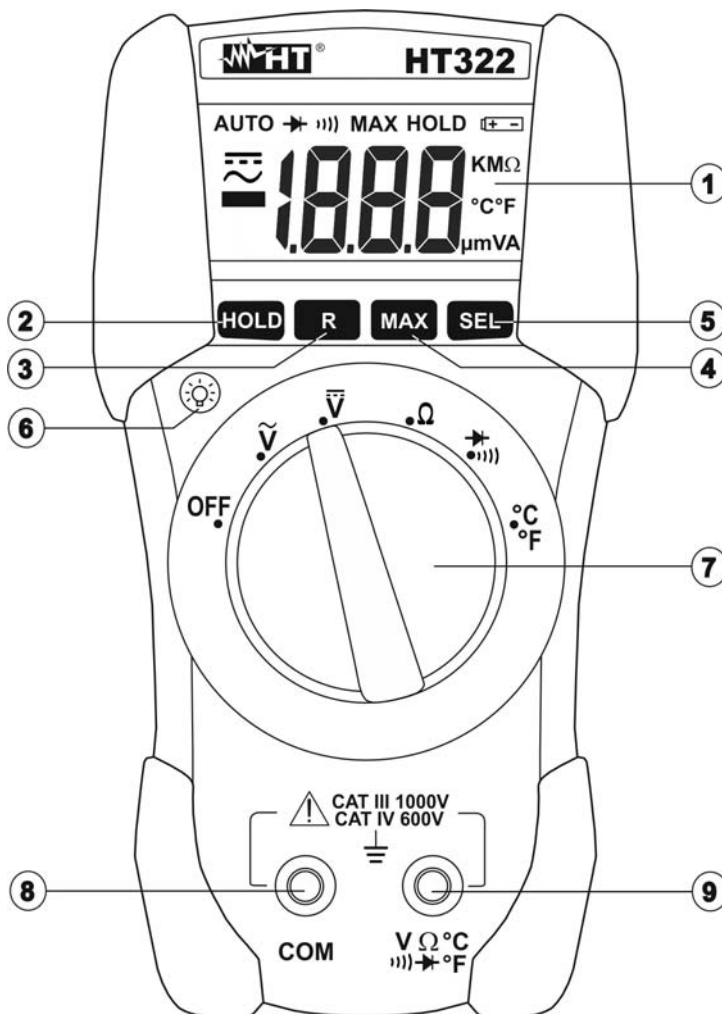

#### CAPTION:

1. LCD
2. HOLD Key
3. R Key
4. MAX Key
5. SEL Key
6. Backlight Key(For HT322)
7. Function selector
8. COM input terminal
9.  $V\Omega \rightarrow \sim$  input terminal (for 321) COM and  $V\Omega \rightarrow \sim$  °C/°F input terminal (for HT322)

Fig. 1: Instrument description

## 4.2. DESCRIPTION OF FUNCTION KEYS

### 4.2.1. HOLD Key

By pressing **HOLD** key the measured value is frozen on the display where the symbol "HOLD" appears. Pressing again **HOLD** to disable this function and resume normal operation.

### 4.2.2. R (RANGE) Key

By pressing **R** key, the manual mode is activated and the "AUTO" symbol disappears from the display. Press **R** cyclically to change the measuring range and fix the decimal point on the display.

To exit this function keep **R** key pressed for at least 1 second or rotate the selector to another position.



### 4.2.3. MAX Key

By pressing **MAX** key, maximum value are measured. The symbol corresponding "MAX" is displayed. This value is stored and automatically updated as soon as an higher value is measured by meter. Press **MAX** key again or rotate the selector to another position to exit from this function.

### 4.2.4. SEL Key

By pressing **SEL** key the selection of a double measured functions which are present at display is possible. In particular this key is active only in  $\rightarrow (+ \cdot \cdot \cdot)$  position to select between diode test and continuity test or in  $^{\circ}\text{C}^{\circ}\text{F}$  position (only HT322) position to select between  $^{\circ}\text{C}$  and  $^{\circ}\text{F}$  temperature measure.

### 4.2.5. Backlight key (only HT322)

By pressing and hold  key for about 3s it's possible to activate the backlight function on the display. By pressing and hold  key again for about 3s to exit from the function or waiting the automatically disable after some seconds. The function is available on each position of the rotary selector.

### 4.2.6. Auto Power OFF

The instrument automatically turns off 15 minutes after last pressure of keys or last selector rotation. To resume operation turn the selector on OFF and turn on the instrument again.







### 4.3.3. Resistance measurement

#### CAUTION



Before taking resistance measurements in circuit remove power from the circuit being tested and discharge all capacitors.

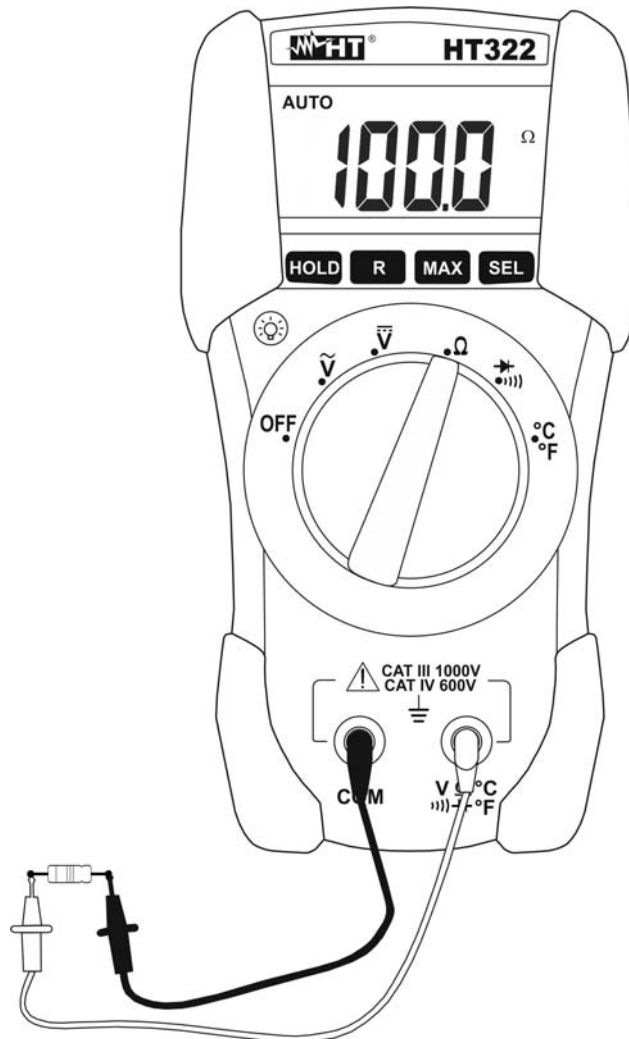

Fig. 4: Using the instrument for Resistance measurement

1. Switch on  $\Omega$
2. Pressing the **R** key to select the correct range or using the Autorange feature (see § 4.2.2). If the resistance value under test is unknown, select the highest range.
3. Insert the test leads into the jack, the red plug into **V $\Omega$  °C °F** (For HT321) / **V $\Omega$  °C °F** (For HT322) jack and black plug into **COM** jack.
4. Connect the test leads to the circuit under test (see **Errore. L'origine riferimento non è stata trovata.**). The resistance value is displayed
5. Indications as ".value  $k\Omega$ " or ".value  $M\Omega$ " (respectively for  $2k\Omega$  or  $2M\Omega$ ) mean **0.value $k\Omega$**  and **0.value $M\Omega$** . The zero before comma is not displayed.
6. If the message "**O.L**" is displayed a higher range must be selected.
7. For HOLD function and Maximum value measurement please refer to § 4.2.

#### 4.3.4. Diode test and Continuity test

### CAUTION



Before taking resistance measurements in circuit remove power from the circuit being tested and discharge all capacitors.

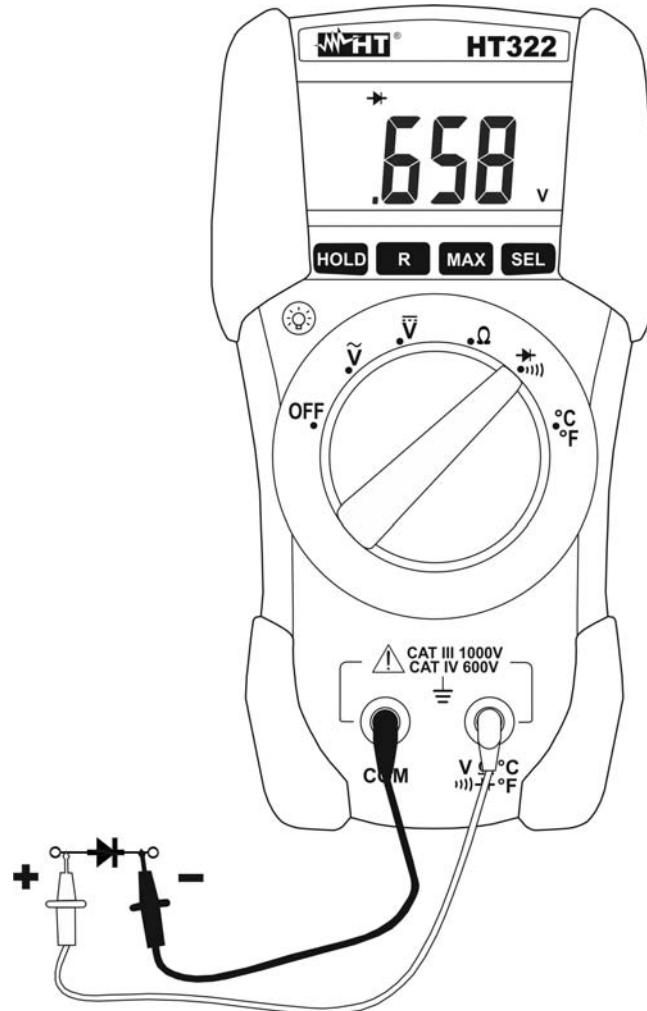

Fig. 5: Using the instrument for Diode test

1. Switch on  $\blacktriangleright|•))$
2. Insert the test leads into the jack, the red plug into  $V\Omega\blacktriangleright|•))$  (for HT321) /  $V\Omega\blacktriangleright|•))\text{ }^{\circ}\text{C}^{\circ}\text{F}$  (for HT322) jack, and black plug into **COM** jack (see Fig. 5)
3. Connect the test leads to the diode under test observing the proper polarities indicated in Fig. 5. The threshold voltage value expressed in mV under this situation is displayed
4. If the message "**O.L.**" is displayed the diode terminals are reversed, the diode P-N junction is damaged
5. For Continuity test switch on  $\blacktriangleright|•))$  then push "**SEL**" button
6. Insert the test leads into the jack, the red plug into  $V\Omega\blacktriangleright|•))$  (for HT321) /  $V\Omega\blacktriangleright|•))\text{ }^{\circ}\text{C}^{\circ}\text{F}$  (for HT322) jack and black plug into **COM** jack
7. Connect the test leads to the circuit under test (see Fig. 4)
8. The resistance value is displayed and the instrument emits a sound signal if the resistance value is  $<120\Omega$
9. The message "**O.L.**" on the display indicates that the resistance value is higher than  $2k\Omega$

#### 4.3.5. Temperature measurement (only HT322)

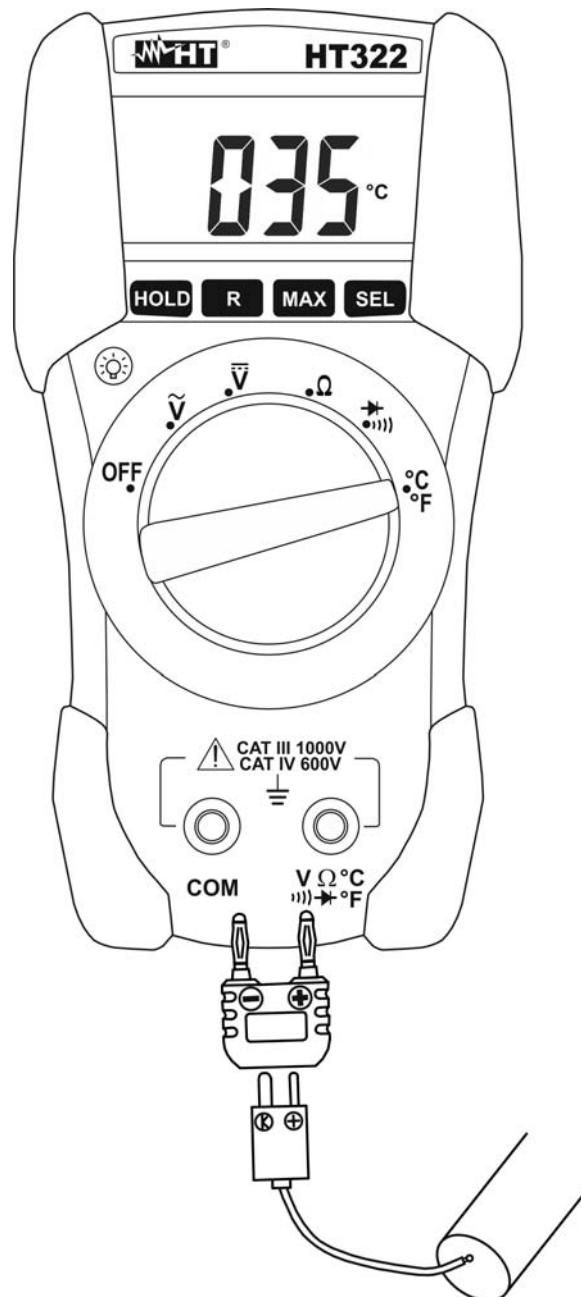

Fig. 6: Using the instrument for Temperature measurement

1. Switch on °C°F.
2. Pressing **SEL** key to select °C or °F measurements
3. Insert the T10 adapter optional accessory into VΩ°C/°F jack, and **COM** jack with respect of red and black colours (see Fig. 6)
4. Connect the optional K probe (see § 6.3.2) into the adapter with respect the correct positive and negative polarity then reading will be displayed
5. For HOLD function and Maximum value measurement please refer to § 4.2

## 5. MAINTENANCE

### 5.1. GENERAL INFORMATION

This is a precision instrument. To guarantee its performances be sure to use it according to these instructions and keep it stored on suitable environmental conditions. Do not expose it to high temperatures or humidity or direct sunlight. Be sure to turn it off after use. If you expect not to use the instrument for a long period remove batteries to avoid leakages of battery liquid which could damage the its inner components.

### 5.2. BATTERY REPLACEMENT

When the low battery indication " is displayed the batteries are to be replaced.

#### CAUTION



Before replacing the battery disconnect test leads from any energised circuits to avoid electrical shocks.

1. Turn off the instrument.
2. Disconnect the test leads from the input terminals.
3. Remove the fixing screws from the back case and detach it.
4. Replace the battery with a new one of the same type (refer to § **Errore. L'origine riferimento non è stata trovata.**) observing the proper polarities.
5. Replace the back case and screws.
6. Use the appropriate battery disposal methods for your area.

### 5.3. CLEANING

To clean the instrument use a soft dry clothe. Never use a wet cloth, solvents or water.

### 5.4. END OF LIFE



Caution: this symbol indicates that equipment and its accessories shall be subject to a separate collection and correct disposal

## 6. TECHNICAL SPECIFICATIONS

### 6.1. TECHNICAL FEATURES

Accuracy is indicated as [%reading + (number of digits\*resolution)] at 23°C±5°C,<75%HR

#### DC Voltage

Range	Resolution	Accuracy	Input Impedance	Overload protection
200mV	0.1mV	±(0.8%rdg +1dgt)	10MΩ	600VDC/ACrms
2V	0.001V			
20V	0.01V			
200V	0.1V			
600V	1V	±(1.0%rdg +2dgt)		

#### AC Voltage

Range	Resolution	Accuracy (45 ÷ 400Hz)	Input Impedance	Overload protection
200mV	0.1mV	not declared	10MΩ	600VCC/CArms
2V	0.001V	±(1.5%rdg+3dgt)		
20V	0.01V			
200V	0.1V			
600V	1 V			

#### Resistance

Range	Resolution	Accuracy	Max Open Loop Voltage	Overload protection
200Ω	0.1Ω	±(1.0%rdg + 8dgt)	About 3.0V	600VDC/ACrms (<30sec.)
2kΩ	0.001kΩ	±(1.0%rdg + 3dgt)		
20kΩ	0.01kΩ			
200kΩ	0.1kΩ			
2MΩ	0.001MΩ			
20MΩ	10kΩ	±(3.0%rdg + 3dgt)		

#### Diode Test

Range	Resolution	Max Open Loop Voltage	Overload protection
	1mV	About 1.5Vdc	600Vrms (< 30sec.)

#### Continuity Test

Range	Beeper	Max Open Loop Voltage	Overload protection
	<120Ω	About 1.5Vdc	600Vrms (< 30sec.)

#### Temperature with K probe (only HT322)

Range	Resolution	Accuracy	Overload protection
-40°C ÷ 1°C	1°C	±5°C	600VDC/ACrms (<30sec.)
0°C ÷ 800°C		±(2.0%rdg + 3dgt)	
-40°F ÷ 31°F	1°F	±9°F	
32°F ÷ 1382°F		±(2.0%rdg + 5dgt)	

### 6.1.1. Safety

The instrument complies with:	IE/EN61010-1
Insulation:	double insulation
Pollution degree:	2
Overvoltage category:	CAT III 1000V, CAT IV 600V
Max height of use:	2000m (6561ft)

### 6.1.2. General data

#### Mechanical characteristics

Dimensions (L x W x H):	163 x 88 x 48mm (6.4 x 3.5 x 1.9in)
Weight (including battery):	280g (9.9 ounces)

#### Power supply

Battery type:	2 x1.5V batteries type AAA MN2400 LR03 AM4
Indication of low battery:	symbol "⊕-⊖" is displayed
Battery life:	Approx. 220 hours

#### Display

Specifications:	3½ LCD with max. reading 1999 counts + symbol and decimal point
-----------------	---

## 6.2. ENVIRONMENT

### 6.2.1. Environmental conditions

Reference temperature:	23 ± 5°C; 73 ± 41°F
Working temperature:	-5 ÷ 40°C; 23 ÷ 104°F
Relative humidity:	<80% HR
Storage temperature:	-10 ÷ 60°C; 14 ÷ 140°F
Storage humidity:	<70% HR

**This product conforms to the prescriptions of the European directive on low voltage 2006/95/EEC (LVD) and to EMC directive 2004/108/EEC.**

## 6.3. ACCESSORIES

### 6.3.1. Standard accessories

- Test leads
- Batteries
- B80: carrying case
- User manual

### 6.3.2. Optional accessories

Couple of test leads	Cod. 4413-2
Adapter for connection type K probe (HT322 only)	Cod. T10
K-type probe for air and gas temperature (HT322 only)	Cod. TK107
K-type probe for semisolid substance temperature (HT322 only)	Cod. TK108
K-type probe for liquid substance temperature (HT322 only)	Cod. TK109
K-type probe for surface temperature (HT322 only)	Cod. TK110
K-type probe for surface temperature with 90° tip (HT322 only)	Cod. TK111

## 7. SERVICE

### 7.1. WARRANTY CONDITIONS

This instrument is guaranteed against material or production defects, in accordance with our general sales conditions. During the warranty period the manufacturer reserves the right to decide either to repair or replace the product.

Should you need for any reason to return back the instrument for repair or replacement take prior agreements with the local distributor from whom you bought it. Do not forget to enclose a report describing the reasons for returning (detected fault). Use only original packaging. Any damage occurred in transit due to non original packaging will be charged anyhow to the customer.

The manufacturer will not be responsible for any damage to persons or things.

The warranty doesn't apply to:

- Accessories and batteries (not covered by warranty).
- Repairs made necessary by improper use (including adaptation to particular applications not foreseen in the instructions manual) or improper combination with incompatible accessories or equipment.
- Repairs made necessary by improper shipping material causing damages in transit.
- Repairs made necessary by previous attempts for repair carried out by non skilled or unauthorized personnel.
- Instruments for whatever reason modified by the customer himself without explicit authorization of our Technical Dept.

The contents of this manual may not be reproduced in any form whatsoever without the manufacturer's authorization.

**Our products are patented and our logotypes registered. We reserve the right to modify specifications and prices in view of technological improvements or developments which might be necessary.**

### 7.2. AFTER-SALE SERVICE

Shouldn't the instrument work properly, before contacting your distributor make sure that batteries are correctly installed and working, check the test leads and replace them if necessary. Make sure that your operating procedure corresponds to the one described in this manual.

Should you need for any reason to return back the instrument for repair or replacement take prior agreements with the local distributor from whom you bought it. Do not forget to enclose a report describing the reasons for returning (detected fault). Use only original packaging. Any damage occurred in transit due to not original packaging will be charged anyhow to the customer.

The manufacturer will not be responsible for any damage to persons or things.