



# M72 – M73 – M 74 – M75

User manual





**Table of contents**

1. SAFETY PRECAUTIONS AND PROCEDURES .....	2
1.1. Preliminary instructions .....	2
1.2. During use .....	3
1.3. After use .....	3
1.4. Overvoltage categories - definitions .....	3
2. GENERAL DESCRIPTION .....	4
2.1. Features .....	4
2.2. TRMS value and mean value - Definitions .....	4
2.3. True root mean square value and crest factor - Definitions .....	4
3. PREPARATION FOR USE .....	5
3.1. Preliminary checks .....	5
3.2. Power supply .....	5
3.3. Calibration .....	5
3.4. Storage .....	5
4. OPERATING INSTRUCTIONS .....	6
4.1. Instrument description .....	6
4.2. Switch on the instrument .....	7
4.3. Disable Auto Power OFF .....	7
4.4. Modify full scale of external transducers .....	7
4.5. Set minimum limit threshold on insulation measurement .....	7
4.6. HOLD, MAX/MIN/AVG, PEAK± .....	8
4.6.1. HOLD .....	8
4.6.2. MAX/MIN/AVG .....	8
4.6.3. PEAK± .....	8
4.7. $V \approx$ Hz: DC/AC voltage and frequency measurement .....	9
4.7.1. Anomalous cases which may occur during $V \approx$ Hz measurements .....	11
4.8. $A \approx$ Hz: DC/AC current and frequency measurement .....	12
4.8.1. Anomalous cases which may occur during $A \approx$ Hz measurements .....	14
4.9. $\Omega \bullet$ ): Resistance measurement and continuity test .....	15
4.9.1. "CAL" mode .....	15
4.9.2. Anomalous cases which may occur during $\Omega \bullet$ ) measurement .....	16
4.10. $\odot$ : Phase sequence and phase conformity measurement .....	17
4.10.1. Anomalous cases which may occur during tests .....	20
4.11. LAN: Cabling test (M75) .....	21
4.11.1. Anomalous cases which may occur during LAN tests .....	22
4.11.2. SPLIT PAIRS - explication note .....	22
4.11.3. Cabling errors detected by the instrument .....	23
4.12. $\Omega 0.2A$ : Continuity test on earth conductors (M72, M74, M75) .....	24
4.12.1. "CAL" mode .....	25
4.12.2. Anomalous cases which may occur during $\Omega 0.2A$ tests .....	27
4.13. $M\Omega$ : Insulation measure (M72, M74, M75) .....	28
4.13.1. Anomalous cases which may occur during $M\Omega$ tests .....	29
4.14. RCD: Tests on AC type RCDs (M73, M74, M75) .....	30
4.14.1. Anomalous cases which may occur during RCD tests .....	31
4.15. $R_a \perp$ : Measurement of global earth resistance (M73, M74, M75) .....	33
4.15.1. Anomalous cases which may occur during $R_a \perp$ tests .....	35
4.16. AUTO: Automatic cycle of measurements (M74, M75) .....	37
5. MAINTENANCE .....	39
5.1. General .....	39
5.2. Battery replacement .....	39
5.3. Cleaning .....	39
5.4. End of life .....	39
6. TECHNICAL SPECIFICATIONS .....	40
6.1. Reference guidelines .....	42
6.2. General specifications .....	42
6.3. Environment .....	42
6.3.1. Environmental conditions .....	42
6.4. Accessories .....	42
7. SERVICE .....	43
7.1. Warranty conditions .....	43
7.2. After-sale service .....	43

## 1. SAFETY PRECAUTIONS AND PROCEDURES

This instrument complies with safety Standards IEC/EN61557-1 and IEC/EN61010-1 related to electronic measuring instruments.



### CAUTION

For your own safety and to avoid damaging the instrument follow the procedures described in this instruction manual and read carefully all notes preceded by this symbol .

When taking measurements:

- Avoid doing that in humid or wet places - make sure that humidity is within the limits indicated in section “environmental conditions”. Avoid doing that in rooms where explosive gas, combustible gas, steam or excessive dust is present
- Keep you insulated from the object under test
- Do not touch exposed metal parts such as test lead ends, sockets, fixing objects, circuits etc
- Avoid doing that if you notice anomalous conditions such as breakages, deformations, fractures, leakages of battery liquid, blind display etc
- Be particularly careful when measuring voltages exceeding 25V in particular places (building yards, swimming pools, etc.) and 50V in ordinary places to avoid risks of electrical shocks.

The following symbols are used:



CAUTION - refer to the instruction manual - an improper use may damage the instrument or its components



CAUTION for dangerous voltage. Risk of electric shock



DC or AC voltage or current



Meter with double insulation



Ground reference



The symbol indicates that the instrument shall not be connected to systems with rated line voltage (Phase to Phase) higher than 605V.

### 1.1. PRELIMINARY INSTRUCTIONS

- This instrument has been designed for use in environments of pollution degree 2
- It can be used for tests on electrical installations of CAT III and 550V maximum rated interlinked voltage (and to earth)
- You are recommended to respect the usual safety regulations aimed at protecting you against dangerous currents and protecting the instrument against improper use
- Only the original test leads supplied along with the instrument guarantee compliance with the safety Standards in force. They must be in a good conditions and, if necessary, replaced with identical ones
- Do not test nor connect to any circuit exceeding the specified overload protection
- Do not take measurements under environmental conditions exceeding the limits indicated in this manual
- Make sure that batteries are correctly installed
- Before connecting the test probes to the installation make sure that the right function is chosen

## 1.2. DURING USE



### CAUTION

An improper use may damage the instrument and/or its components or injure the operator.

- Before selecting any function, first disconnect the test leads from the circuit under test
- When the instrument is connected to circuits never touch any unused terminal
- Do not measure resistance in presence of external voltages; although the instrument is protected, an excessive voltage may cause malfunctioning.



### CAUTION

If the “low battery” symbol is displayed during use interrupt testing and replace batteries following the procedure described in § 5.2.

## 1.3. AFTER USE

- Disconnect the test leads from the circuit under test and switch off the instrument
- If you expect not to use the instrument for a long period remove batteries

## 1.4. OVERVOLTAGE CATEGORIES - DEFINITIONS

Standard IEC/EN61010-1 (Safety requirements for electrical equipment for measurement, control and laboratory use, Part 1: General requirements) defines what a measurement category (usually called “overvoltage category”) is. At § 6.7.4: Measuring circuits it says:

Circuits are divided into the following measurement categories:

- **Measurement category IV** is for measurements performed at the source of the low-voltage installation.  
*Examples are electricity meters and measurements on primary overcurrent protection devices and ripple control units.*
- **Measurement category III** is for measurements performed in the building installation.  
*Examples are measurements on distribution boards, circuit breakers, wiring, including cables, bus-bars, junction boxes, switches, socket-outlets in the fixed installation, and equipment for industrial use and some other equipment, for example, stationary motors with permanent connection to fixed installation.*
- **Measurement category II** is for measurements performed on circuits directly connected to the low voltage installation.  
*Examples are measurements on household appliances, portable tools and similar equipment.*
- **Measurement category I** is for measurements performed on circuits not directly connected to MAINS.  
*Examples are measurements on circuits not derived from MAINS, and specially protected (internal) MAINS-derived circuits. In the latter case, transient stresses are variable; for that reason, the norm requires that the transient withstand capability of the equipment is made known to the user.*

## 2. GENERAL DESCRIPTION

Dear Customer, the instrument you have purchased, whether used according to the instructions given in this manual, will grant you accurate and reliable measurements. Thanks to a development of newest conception assuring double insulation and overvoltage category III you will enjoy the highest safety. This manual refers to the entire range of Multitest family including M72, M73, M74 e M75 models. Except where otherwise expressly indicated, this manual refers to all these models.

### 2.1. FEATURES

- ☞ **V  $\approx$  Hz:** DC and AC TRMS voltage measurement, frequency measurement.
- ☞ **A  $\approx$  Hz:** DC and AC TRMS current measurement, frequency measurement by means of current transducer (clamp) with max. full scale of 1V.
- ☞  **$\Omega$  (•••):** measurement of resistance / continuity with sound signal
- ☞  **$\odot$ :** phase sequence detection at one or two terminals
- ☞ **LAN:** wire mapping for cables UTP/STP in any category with connector RJ45 capable of measuring through connection to remote unit (M75).
- ☞  **$\Omega$  0.2A:** continuity test on earth, protective and potential equalising conductors with a test current higher than 200mA and open voltage ranging from 4V to 24V (M72, M74, M75)
- ☞ **M $\Omega$ :** insulation resistance measurement with test DC voltage of 250, 500VDC (M72, M74, M75)
- ☞ **RCD:** measurement on RCDs type AC ( $\sim$ )(M73, M74, M75)
- ☞ **Ra  $\perp$ :** measurement of total earth resistance (M73, M74, M75)
- ☞ **AUTO** performance of measurements in **Ra  $\perp$** , **RCD** and **M $\Omega$**  with automatic sequence ( M74, M75)

### 2.2. TRMS VALUE AND MEAN VALUE - DEFINITIONS

Safety testers for alternate quantities are divided into two categories:

- MEAN VALUE instruments: instruments measuring only the value of the wave at the fundamental frequency (50 or 60Hz).
- True Root Mean Square (TRMS) instruments: instruments measuring the true root mean square value of the quantity under test.

Mean value instruments provide only the value of the fundamental wave while TRMS instruments provide the value of the entire wave, including harmonics (within the passband of the instrument). Accordingly, the measured values are identical only if the wave is purely sinusoidal.

### 2.3. TRUE ROOT MEASN SQUARE VALUE AND CREST FACTOR - DEFINITIONS

The current effective value is defined as follows: "In an interval of time equivalent to a period, an alternate current with effective value having an intensity of 1A, by passing on a resistor, disperses the same energy which would be dispersed in the same period of time by a direct current having an intensity of 1A". From this definition we get the numerical expression:  $G = \sqrt{\frac{1}{T} \int_{t_0}^{t_0+T} g^2(t) dt}$  The effective value is indicated as RMS (*root mean square*).

The crest factor is defined as the ratio between the peak value of a signal and its effective value:  $CF (G) = \frac{G_p}{G_{RMS}}$ . This value varies according to the waveform of the signal, for a purely

sinusoidal wave it's worth  $\sqrt{2} = 1.41$ . In presence of distortions, the higher the wave distortion is, the higher the crest factor values get.

### **3. PREPARATION FOR USE**

#### **3.1. PRELIMINARY CHECKS**

This instrument was checked both mechanically and electrically prior to shipment. All possible cares and precautions were taken to let you receive the instrument in perfect conditions. Notwithstanding we suggest you to check it rapidly (eventual damages may have occurred during transport – if so please contact the local distributor from whom you bought the item).

Make sure that all standard accessories mentioned in § 6.4 are included.

Should you have to return back the instrument for any reason please follow the instructions mentioned in § 7.

#### **3.2. POWER SUPPLY**

The instrument is powered by 4x1.5V batteries type AA LR6. When batteries are low, a low battery indication "⚡" is displayed. To replace/insert batteries follow the instructions indicated in § 5.2.

#### **3.3. CALIBRATION**

The instrument complies with the technical specifications contained in this manual and such compliance is guaranteed for 12 months. Annual recalibration is recommended.

#### **3.4. STORAGE**

After a period of storage in extreme environmental conditions exceeding the limits mentioned in § 6.3.1 let the instrument resume normal measuring conditions before using it.

## 4. OPERATING INSTRUCTIONS

### 4.1. INSTRUMENT DESCRIPTION



**CAPTION:**

1. Inputs
2. LCD Display
3. **ON/OFF** key
4. **MODE/PEAK** key
5. Arrows key
6. **FUNC/HOLD** key
7. **GO** key
8. Remote units for LAN tests (M75)

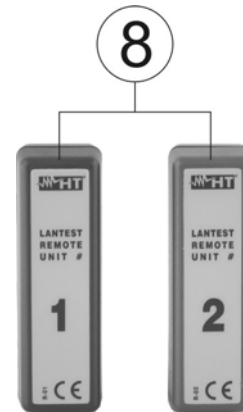
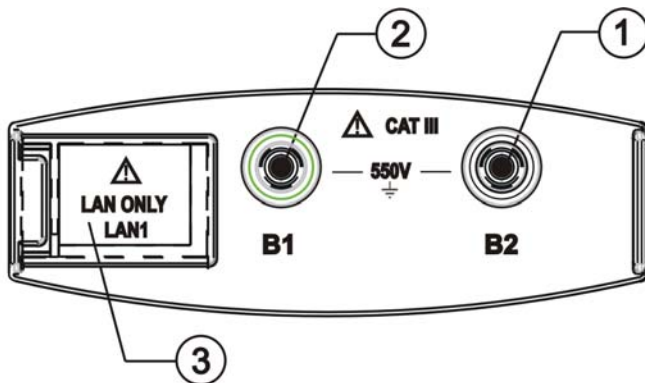

Fig. 1: Instrument description



**CAPTION:**

1. Input terminal **B2**
2. Input terminal **B1**
3. Sliding cover for RJ45 connectors of LAN networks (M75)

Fig. 2: Instrument inputs description

	<b>ON/OFF</b> key To switch on/off the instrument		<b>GO</b> key to start a measurement
	<b>MODE/PEAK</b> key to select working mode and to select peak measurement		Arrow keys to select measurements
	<b>FUNC/HOLD</b> key to select internal functions and to stop display updating		

Table 1: Instrument function keys description



#### 4.2. SWITCH ON THE INSTRUMENT

When the instrument is turned on, it emits a brief sound and all display segments are lit for just one second. Then the model number and the firmware release appear on the display (see picture referred to M75). Finally the instrument is ready for operation.

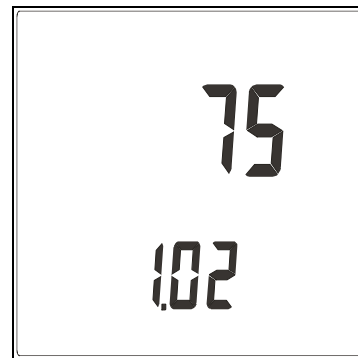

#### 4.3. DISABLE AUTO POWER OFF

The instrument automatically turns off 10 minutes after last pressure of keys. To resume operation turn on the instrument again. When the instrument must be used for long periods, the operator may need to disable the Auto Power Off function. In order to do so:

1. Keep pressed the **FUNC/HOLD** key while turn on the instrument with the **ON/OFF** key.  
The symbol “☺” disappear at display
2. On next switch on auto power off will be automatically restored and the symbol “☺” appear at display

#### 4.4. MODIFY FULL SCALE OF EXTERNAL TRANSDUCERS

The instrument measures AC/DC current through a clamp transducer to be connected to the input terminals. Unlike traditional multimeters it's therefore not necessary to interrupt the current circuit to insert the measuring device. Besides it's possible to use more clamps having different full scales according to the current to be measured from time to time. To set the full scale of the clamp being used follow the herewith steps:

1. Keep pressed the **MODE/PEAK** key while turn on the instrument with the **ON/OFF** key.  
The instrument displays the “SET” message and the value of the set full scale
2. Press the arrow keys to select the desired full scale (the possible values are **1, 10, 20, 30, 100, 200, 300, 400, 1000, 2000, 3000A**)
3. Press **MODE/PEAK** key twice to validate the modification

#### 4.5. SET MINIMUM LIMIT THRESHOLD ON INSULATION MEASUREMENT

To set the minimum limit threshold recognized by the instrument in the insulation measurement (see § 4.13) follow the herewith steps:

1. Keep pressed the **MODE/PEAK** key while turn on the instrument with the **ON/OFF** key.  
The instrument displays the “SET” message and the value of the set full scale
2. Press the arrow keys to select the desired value (possible value are **0.25, 0.50, 1.00MΩ**)
3. Press **MODE/PEAK** key to validate the modification

#### 4.6. HOLD, MAX/MIN/AVG, PEAK±

The following functions are available for measurements of AC and DC voltage, AC current, frequency and resistance.

##### 4.6.1. HOLD

The HOLD function permits to block on the display the detected value during measurements of AC and DC voltage, AC and DC current, frequency and resistance. Just press **FUNC/HOLD** for at least one second. The symbol HOLD is displayed. To escape this function press again **FUNC/HOLD** or the arrow keys. This function is not available when MAX/MIN/AVG or PEAK± functions are active.

##### 4.6.2. MAX/MIN/AVG

During measurements of AC and DC voltage, AC and DC current, frequency and resistance it's possible to measure and display the maximum (MAX), minimum (MIN) and average (AVG) value of the quantity under test. Press **FUNC/HOLD** for more than one second to enter this function and press it repeatedly for less than one second to run through MAX, MIN or AVG. The corresponding symbol is displayed. Maximum, minimum and average values are detected since this function is activated and are continuously updated even if not displayed. For example, while the AC current average value is displayed, the maximum and minimum values of the same quantity are continuously updated. To escape the MAX/MIN/AVG function press again **FUNC/HOLD** for more than one second or the arrow keys.

The MAX/MIN/AVG function is not available when HOLD or PEAK± functions are active.

##### 4.6.3. PEAK±

During measurements of AC and DC voltage and AC/DC current it's possible to measure and display the maximum (PEAK+) and minimum (PEAK-) peak values of the quantity under test with a resolution of 1ms. Press **MODE/PEAK** for more than one second to enter this function and press it repeatedly for less than one second to run through PEAK+ or PEAK-. The corresponding symbol is displayed.

Maximum and minimum peak values are detected since this function is activated and are continuously updated even if not displayed. For example, while the maximum peak values of AC current is displayed, the minimum peak value of the same quantity is continuously updated.

When displaying maximum and minimum peaks it's not mentioned whether the corresponding quantity is AC or DC: a peak value is absolutely a peak value, regardless of the quantity at which it's detected. To escape this function press again **MODE/PEAK** for more than one second or the arrow keys.

The HOLD and MAX/MIN/AVG functions are not available when when PEAK± is active.

#### 4.7. $V \approx$ HZ: DC/AC VOLTAGE AND FREQUENCY MEASUREMENT

### CAUTION



The maximum input voltage is  $550+10\%V$ . Don't try to measure higher voltages to avoid risks of electrical shocks or serious damages to the instrument.

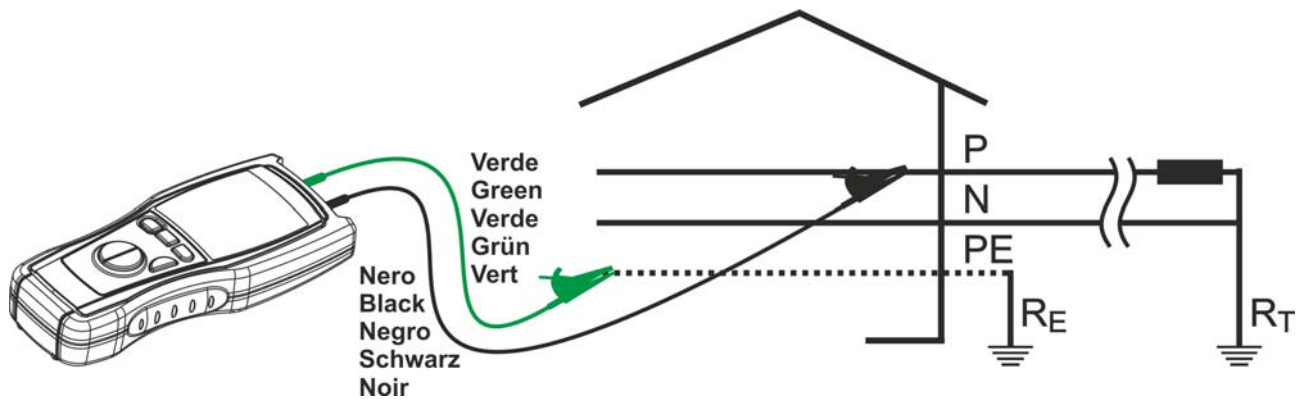
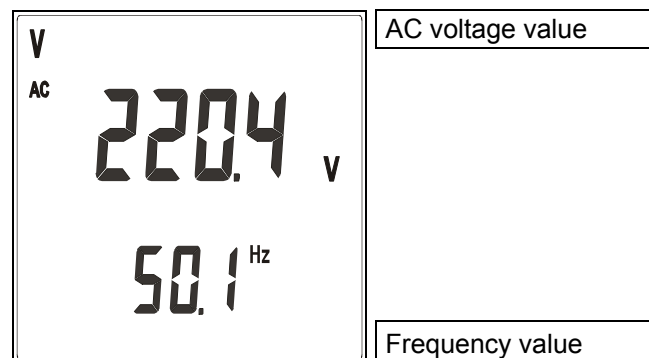
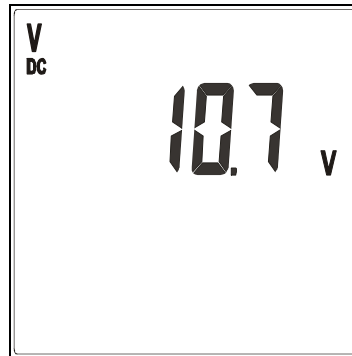

Fig. 3: Connection of the instrument's terminals during  $V \approx$  Hz test

1. Turn on the instrument
2. Press the arrow keys to select  $V \approx$  Hz
3. Insert the black and green cables in the corresponding input terminals of the instrument
4. If necessary, insert the croco clips on the test probes
5. Connect the cables to the desired points of the circuit under test as shown in Fig. 3. The voltage and frequency values will be displayed with automatic range selection.
6. The instrument automatically switches from AC to DC voltage basing on the signal applied to terminals.
7. Example of display of AC voltage and frequency values. The minimum reading limit of AC voltage is 0.5V. Lower input values are displayed as 0.0V



8. Example of display of DC voltage. The minimum reading limit of DC voltage is 1.2V. Lower input values are displayed as 0.0V



DC voltage value

9. Press **MODE/PEAK** for less than 1 second to pass to frequency measurement (only during AC measurement)
10. Press **MODE/PEAK** for more than 1 second to detect the voltage peak value (see § 4.6.3)
11. Press **FUNC/HOLD** for less than 1 second to block the detected values on the display (see § 4.6.1)
12. Press **FUNC/HOLD** for more than 1 second to detect maximum, minimum and average voltage values (see § 4.6.2)

### Frequency measurement

1. In order to detect minimum, average, maximum and peak values of frequency it's necessary to pass to this measuring parameter
2. During AC measurements it's possible to pass to frequency measurement by pressing **MODE/PEAK** for less than 1 second

3. Example of display of frequency value. The minimum reading limit of frequency is 30.0Hz. Lower input values are displayed as <30.0Hz

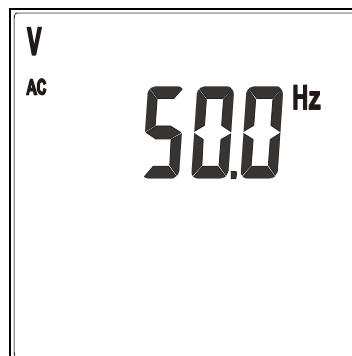

Frequency value

4. To resume voltage measurement press **MODE/PEAK** for less than 1 second
5. To detect the frequency peak value press **MODE/PEAK** for more than 1 second (see § 4.6.3)
6. To block the detected frequency value on the display press **FUNC/HOLD** for less than 1 second (see § 4.6.1)
7. To detect maximum, minimum and average frequency values press **FUNC/HOLD** for more than 1 second (see § 4.6.2)

#### 4.7.1. Anomalous cases which may occur during $V_{\approx}$ Hz measurements

1. The maximum input voltage is  $550+10\%V$ .

If the detected voltage value exceeds **605V TRMS** the instrument displays the screen beside.

Disconnect immediately the instrument from the circuit under test to avoid electrical shocks and damages to the instrument

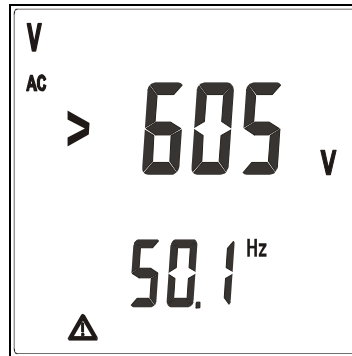

2. If during a voltage measurement the detected frequency value exceeds **400Hz** the instrument displays the screen beside

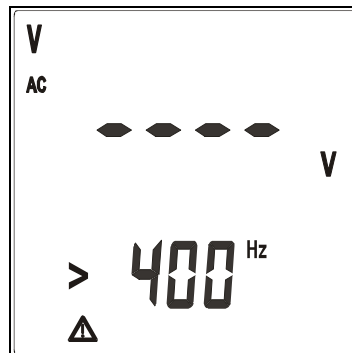

3. If during a frequency measurement the detected value exceeds **400Hz** the instrument displays the screen beside

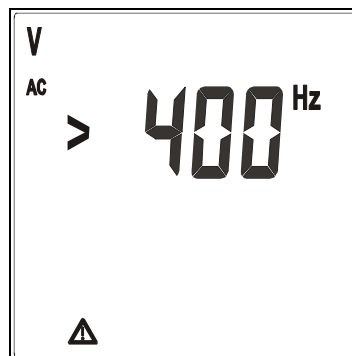

4. If during a frequency measurement the detected value does not reach **30.0Hz** the instrument displays the screen beside

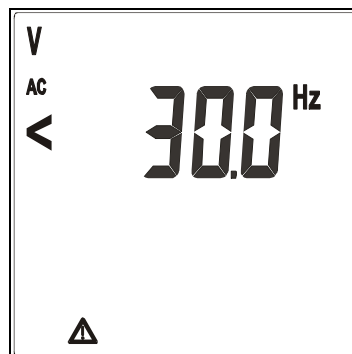

#### 4.8. $A \approx$ HZ: DC/AC CURRENT AND FREQUENCY MEASUREMENT

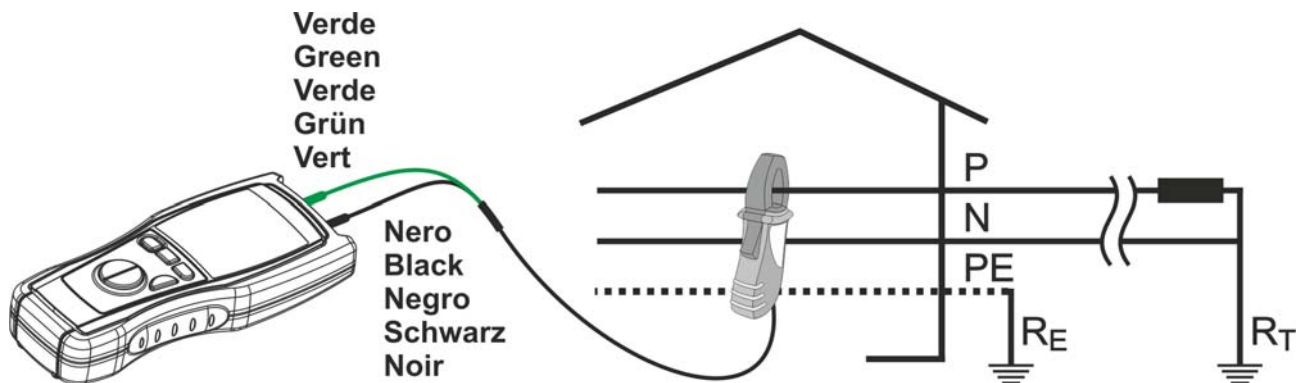
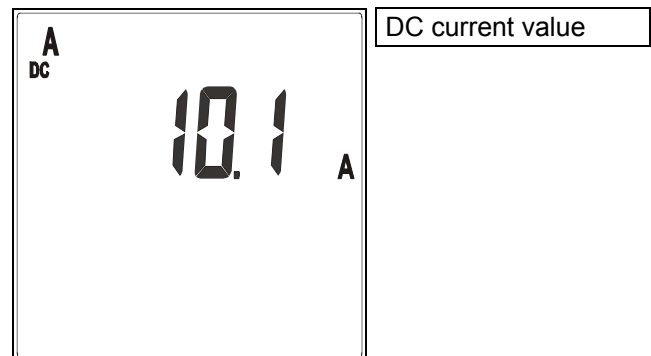
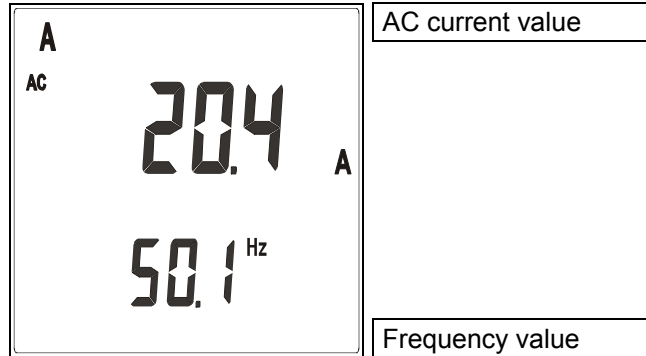

Fig. 4: Connection of the instrument's terminals during  $A \approx$  Hz test

1. Turn on the instrument
2. Press the arrow keys to select  **$A \approx$  Hz**
3. Insert the banana connectors of the clamp transducer in the corresponding input terminals of the instrument (black with black, green or red with green). For transducers with FRB hypertac connector is necessary the **NOCANBA** optional accessory
4. Make sure that the clamp full scale and the instrument full scale do correspond. If they do not, the measured value will be wrong. To set the clamp full scale refer to § 4.4
5. Open the jaws and insert the cable in the very middle as shown in Fig. 4. Current and frequency values will be displayed
6. The instrument automatically switches from AC to DC current basing on the signal applied to terminals
7. Example of DC current displaying. The minimum limit of DC current is:  
1.0mV x transduction ratio of the clamp  
lower values are nullified



8. Example of AC current displaying. The minimum limit of AC current is:  
 $1.0\text{mV} \times$  transduction ratio of the clamp  
lower values are nullified.



The minimum reading value of AC and DC current is given by the herewith:

**$1\text{mV} \times$  transduction ratio of the clamp**

Therefore, with a clamp 400A/400mV, the minimum measurable current is 1.0A.  
Lower input values are displayed as 0.0A

9. To pass to frequency measurement press **MODE/PEAK** for less than 1 second (only during AC current measurements)
10. To detect the current peak value press **MODE/PEAK** for more than 1 second (see § 4.6.3)
11. To block the detected values on the display press **FUNC/HOLD** for less than 1 second (see § 4.6.1)
12. To detect maximum, minimum and average current values press **FUNC/HOLD** for more than 1 second (see § 4.6.2)

**Frequency measurement**

1. In order to detect minimum, average, maximum and peak values of frequency it's necessary to pass to this measuring parameter.
2. It's possible to pass to frequency measurement by pressing **MODE/PEAK** for less than 1 second

3. Example of display of frequency value. The minimum reading limit of frequency is 30.0Hz. Lower input values are displayed as <30.0Hz

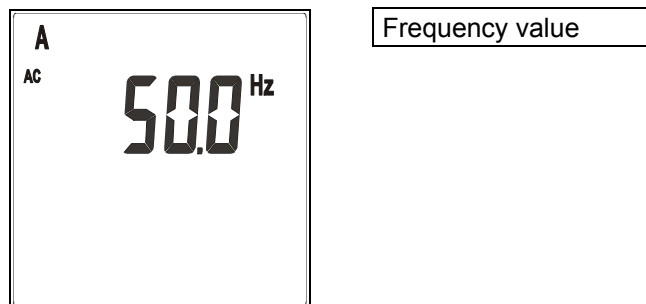

4. To resume voltage measurement press **MODE/PEAK** for less than 1 second
5. To detect the frequency peak value press **MODE/PEAK** for more than 1 second (see § 4.6.3)
6. To block the detected frequency value on the display press **FUNC/HOLD** for less than 1 second (see § 4.6.1)
7. To detect maximum, minimum and average frequency values press **FUNC/HOLD** for more than 1 second (see § 4.6.2)

#### 4.8.1. Anomalous cases which may occur during $A \approx$ Hz measurements

1. If the detected current value exceeds the clamp full scale the instrument displays the screen beside.

Disconnect immediately the clamp from the circuit under test to avoid electrical shocks and damages to the instrument  
The instrument is 20% overchargeable than the clamp full scale

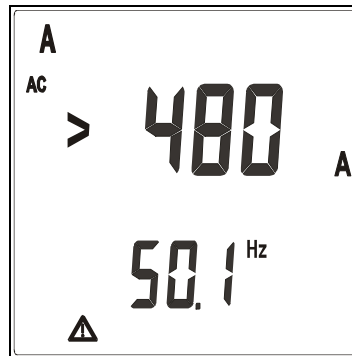

Example of clamp full scale set at 400A AC

2. If during a current measurement the detected frequency value exceeds 400Hz the instrument displays the screen beside

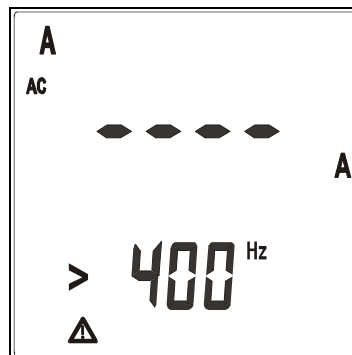

3. If during a frequency measurement the detected value exceeds 400Hz the instrument displays the screen beside

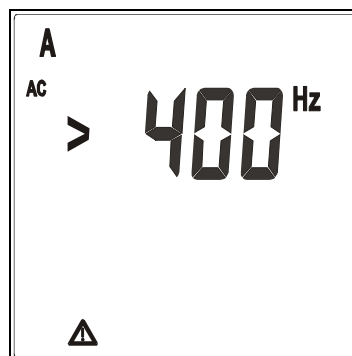

4. If during a frequency measurement the detected value does not reach 30.0Hz the instrument displays the screen beside

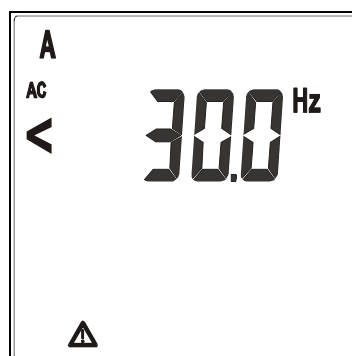



#### 4.9. $\Omega$ : RESISTANCE MEASUREMENT AND CONTINUITY TEST



### CAUTION

Before taking resistance measurements make sure that the circuit under test is not powered and that eventual condensers are discharged.

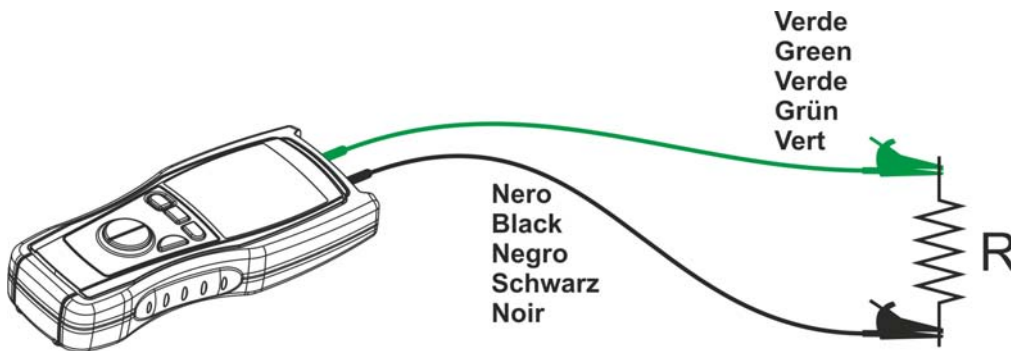
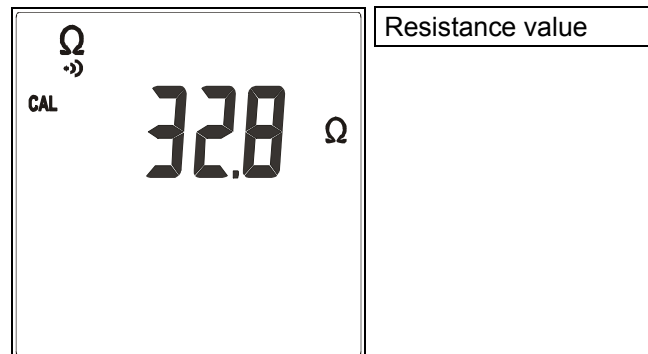

Fig. 5: Connection of the instrument's terminals

1. Turn on the instrument
2. Press the arrow keys to select  $\Omega$
3. If the measuring cables being used have not been calibrated, first calibrate them as described in § 4.9.1
4. Insert the black and green cables in the corresponding input terminals of the instrument
5. Position the test probes on the desired points of the circuit under test (see Fig. 5)
6. Example of display of resistance value. If such value is lower than  $40\Omega$  the instrument emits an acoustic signal
7. To block the detected value on the display press **FUNC/HOLD** for less than 1 second (see § 4.6.1)
8. To detect maximum, minimum and average values press **FUNC/HOLD** for more than 1 second (see § 4.6.2)
9. The measured value is out of accuracy if an input voltage is present



##### 4.9.1. "CAL" mode

1. Any addition or replacement of cables, extensions and croco clips nullify the previous calibration and make necessary a new calibration before performing further measurements. Therefore the instrument must be calibrated in the same conditions at which it will operate during measurements
2. Short-circuit the cable ends with each other as shown in Fig. 6 making sure that the metallic parts of test probes and crocodiles are in good touch

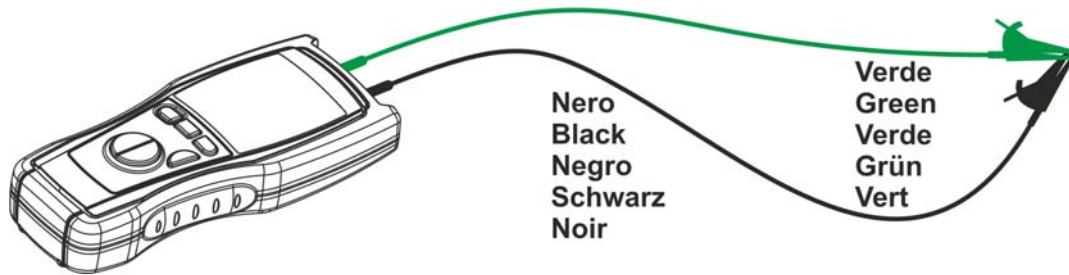

Fig. 6: Connection of the instrument's terminals during calibration procedure

3. Press **MODE/PEAK** for more than 1 second. The instrument resets the resistance of the cables, the symbol "**CAL**" is displayed



### CAUTION

While **MODE/PEAK** is pressed the instrument is measuring. During this phase never disconnect test leads.

4. The instrument performs the calibration of cables with resistance **lower than 5Ω**
5. At the end of the test the measured value is stored by the instrument and used as **OFFSET**, which means it's deducted from all continuity tests performed) for all further measurements until a new calibration is made
6. If the value measured during the calibration phase is higher than 5Ω (e.g. open terminals) the instrument interrupts the calibration, removes the offset value previously stored and does not display the **CAL** symbol until the next positive calibration. This method can be used to nullify the last calibration performed
7. Each time the instrument is switched off the calibrated value is lost

#### 4.9.2. Anomalous cases which may occur during $\Omega \rightarrow$ measurement

1. The full scale of the instrument is 39.99kΩ.  
If the resistance value is higher than this value, or in case of open or interrupted probes, the instrument displays the screen beside

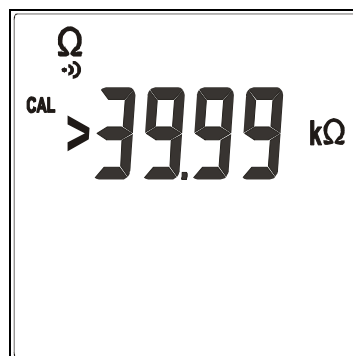

#### 4.10. ⚠: PHASE SEQUENCE AND PHASE CONFORMITY MEASUREMENT

### CAUTION



The maximum input voltage is  $550+10\%V$ . Don't try to measure higher voltages to avoid risks of electrical shocks or serious damages to the instrument. Do not use the instrument on plants whose interlinked rated voltage is higher than 550V.

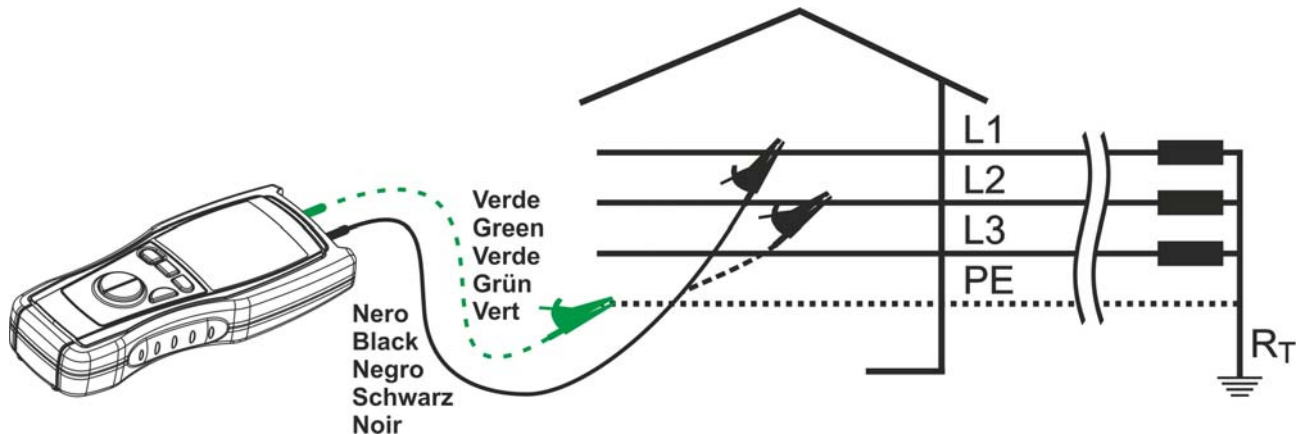

Fig. 7: Connection of the instrument's terminals during test

1. Turn on the instrument
2. Press the arrow keys to select ↻
3. Press **MODE/PEAK** to select function "1W" (1-wire mode) or "2W" (2-wire mode)

### CAUTION



1W mode requires the operator to touch the measuring key (without gloves) and be at the earth potential, and the star centre of the system under test to be at the earth potential. Only if these conditions are met mode 1W provides correct results. In absence of just one of the above mentioned conditions (operator wearing protective gloves or mounting a ladder, IT systems etc.) select mode 2W.

4. Insert the black wire in the corresponding input terminal of the instrument. If necessary install the croco-clip on the test probe
5. If mode 2W has been selected, insert the green wire in the corresponding input terminal of the instrument and connect the test probe to the neutral wire or to the neutral wire of the plant under test. If necessary install the croco-clip on the test probe
6. Following messages are displayed:  
**"MEASURING..."** the instrument is ready to measure the first phase voltage  
**"PH1"** (secondary display): the operator is invited to connect the measuring cable to the cable of the L1 phase voltage (see § Fig. 7)

### CAUTION



For a correct functioning of mode 1W it's necessary that the star centre of the three-phase triad under test is at the earth potential.

In plants with insulated neutral wire, like IT systems (often present in hospitals, airports etc.) it's necessary to select mode 2W and connect the green probe to the neutral conductor (not to the protective conductor). In this kind of plants mode 1W may not provide correct results.

7. **Only for 1W mode** press and keep pressed **GO**, or simply touch the surface of the key for the entire duration of the measurement. Connect the test probe to the first wire of the three-phase triad to be tested
8. When a higher voltage than 110V is detected, the symbol "**PH**" is displayed and the buzzer emits a prolonged sound

### CAUTION



During measurement:

- **GO** must be always kept pressed or at least its surface must be always touched (only for mode 1W)
- The test probe, except for the phase cable under test, must not be in touch or close to any voltage source which may block the measurement due to the instrument's sensitivity
- The test probe must be kept in touch with the phase cable.

9. At the end of the measurement the wordings "**MEASURING...**" and "**PH1**" disappear. The buzzer emits an intermitting sound until the test probe is disconnected from the phase cable
10. Disconnect the test probe from the cable of the first phase voltage. The wording "**PH**" (present only when the input voltage is detected) disappears from the display
11. Only for mode 1W keep pressed **GO**, or simply touch its surface, for the entire duration of the measurement. An eventual release and new pressure on the key cancels all performed measurements. In this case repeat all previous passages starting from point 6
12. Following messages are displayed:  
"**MEASURING...**" the instrument is ready to measure the second phase voltage  
"**PH2**" (secondary display): the operator is invited to connect the measuring cable to the cable of the L2 phase voltage (see § Fig. 7)

### CAUTION



If more than 10 seconds pass between the first and the second measurement, a message "**t.out**" is displayed. In this case it's necessary to repeat the entire procedure. Press **GO** and re-start from point 6.

13. Only for mode 1W keep pressed **GO**, or simply touch its surface, for the entire duration of the measurement. Connect the test probe to the second cable of the three-phase triad to be tested
14. When a higher voltage than 110V is detected, the symbol "**PH**" is displayed and the buzzer emits a prolonged sound

### CAUTION



During measurement:

- **GO** must be always kept pressed or its surface must be always touched (only for mode 1W)
- The test probe, except for the phase cable under test, must not be in touch or close to any voltage source which may block the measurement due to the instrument's sensitivity
- The test probe must be kept in touch with the phase cable.

15. At the end of the test, if two tested cables are in a correct phase sequence, the instrument emits a double sound to signal the positive outcome of the test and displays a screen like this

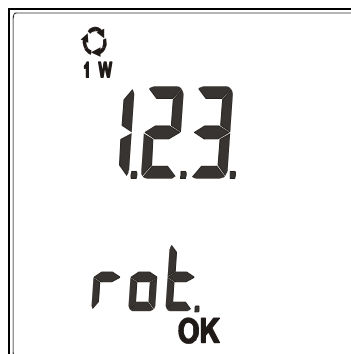

Correct phase sequence

Phase rotation

16. At the end of the test, if two cables belong to the same phase, the instrument emits a double sound to signal the positive outcome of the test and displays a screen like this

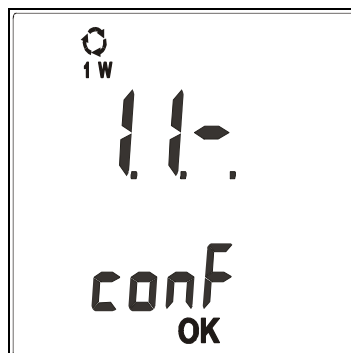

Cables belonging to the same phase

Compliance between one cable and another

17. At the end of the test, if two tested cables are not in the correct phase sequence, the instrument emits a prolonged sound to signal the negative outcome of the test and displays a screen like this

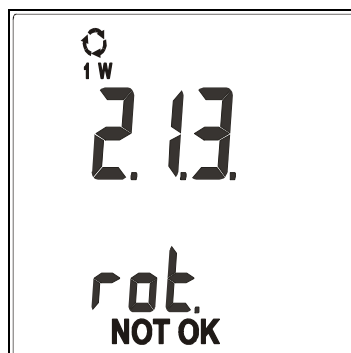

Wrong phase sequence

Phase rotation

18. To perform a new measurement press **GO**, then re-start from point 6

### CAUTION



Although two cables are in sequence it doesn't mean that the third cable is in sequence too. It's not excluded that the cabling was made by mistake with a double phase cable. To clear any possible doubt always perform at least two measurements by testing the cables two by two.

#### 4.10.1. Anomalous cases which may occur during tests

1. If you wait more than 10 seconds between the first measurement and the second one, the instrument emits a prolonged sound to signal the negative outcome of the test and displays a screen like this. It's necessary to repeat the entire procedure. Press **GO** and re-start from point 6

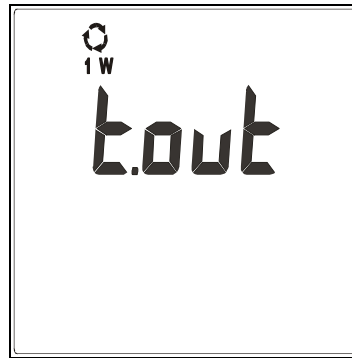

2. If mode 1W is selected and the instrument detects the connection of the second probe like in mode 2W, a screen like this is displayed to signal the error. A prolonged sound is emitted until the error condition is removed

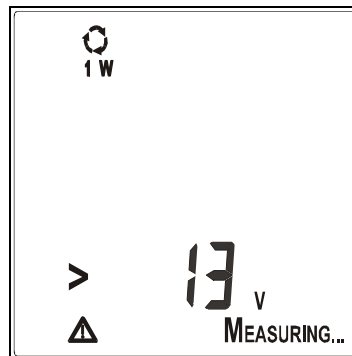

3. If mode 2W is selected and the instrument detects an input voltage (between the two bushes) higher than 605V, a screen like this is displayed and a prolonged sound is emitted until the error condition is removed. Disconnect the instrument promptly

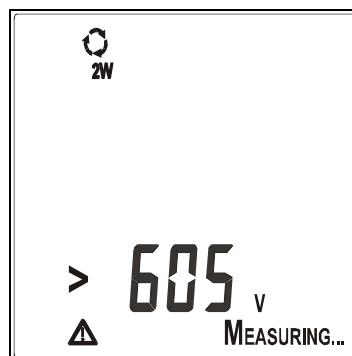

#### 4.11. LAN: CABLING TEST (M75)

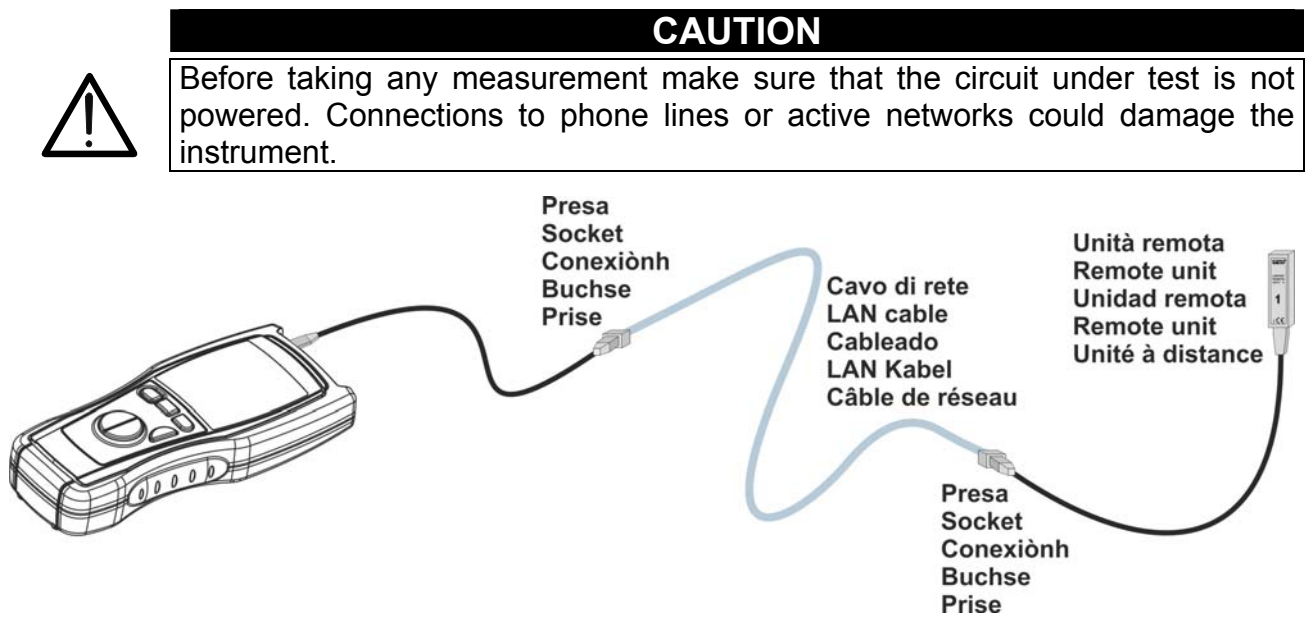



Fig. 8: Connections of the instrument's terminals during LAN tests

1. Turn on the instrument
2. Press the arrow keys to select **LAN**
3. Select the type of cable under test by pressing **MODE/PEAK**: set **STP** whether shielded, **UTP** whether unshielded
4. Connect the cable under test to the instrument and to the remote unit if necessary through patch cables (see Fig. 8)

CAUTION



The remote unit must be necessarily connected to the other end of the cable being tested, otherwise no measurement is performed.

5. Press **GO** to perform all tests related to the selected type of cable

6. If cabling is correct, a screen like this is displayed. The identification number (02) refers to the remote unit connected to the other end of the cable being tested

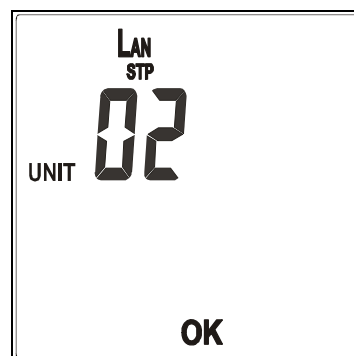

Identification number of the remote unit

7. If cabling is not correct, a screen like this is displayed (NOT OK). Referring to this example, “FAULT 1/4” means that the detected errors are 4, of which the first one is currently displayed. Details on the detected error are given on the right side: the couple 1-2 is open. By pressing **FUNC HOLD** key it’s possible to run over the remaining screens and display other cabling errors (“FAULT 2/4”, “FAULT 3/4”, “FAULT 4/4”). The number of the remote unit can be not displayed

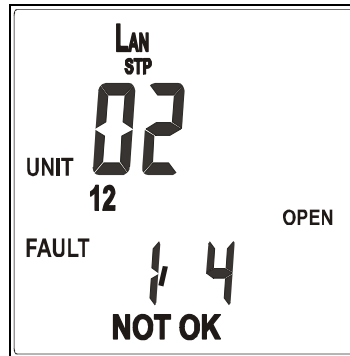

Identification number of the remote unit (if possible to find it)

Number of the displayed error / number of the detected errors

### CAUTION



It’s indispensable to select the right type of cable. If UTP is selected although a STP cable is tested, test results may be not reliable due to the shield affecting the measurement.

#### 4.11.1. Anomalous cases which may occur during LAN tests

If the voltage present at the terminal is higher 0.2V the instrument does not perform the test and emits a sound to signal the anomalous situation. The screen beside is displayed.

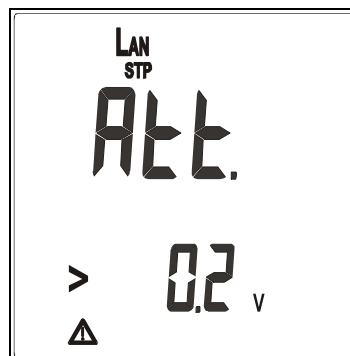

### CAUTION



Before taking any measurement make sure that the circuit under test is not powered. Connections to phone lines or active networks could damage the instrument.

#### 4.11.2. SPLIT PAIRS - explication note

A LAN cable contains 8 conductors, twisted two by two thus forming 4 pairs: 1-2, 3-6, 4-5, 7-8. The error “SPLIT PAIRS” consists in the exchange of two conductors belonging to different pairs. The pin to pin correspondence seems intact, but physically the conductors of two couples are split. Such interaction hardly affects (or even makes impossible) the exchange of data at high frequency/speed.

### CAUTION



The error condition “SPLIT PAIRS” is verified only when the cable mapping is fully correct. For a correct detection of such error condition it’s necessary that the cable under test is at least 1m long.



### 4.11.3. Cabling errors detected by the instrument

Cabling errors	Description	Visualization	Mapping
OPEN PAIR	One or both conductors of the pair are interrupted (open)		
REVERSED PAIR	The conductors of the same pair are reversed		
SHORTED CABLES	Two conductors are in short circuit between each other		
TRANSPOSED (CROSSED) PAIRS	Two pairs are crossed		
MISWIRE	Generic cabling error, such as for example two conductors belonging to different pairs are exchanged		
SPLIT PAIRS	The pin to pin correspondence is hold, but physically the conductors of two pairs are crossed		

Table 2: Possible cabling errors detected by the instrument

#### 4.12. $\Omega 0.2A$ : CONTINUITY TEST ON EARTH CONDUCTORS (M72, M74, M75)

The measurement is performed with a test current  $>200\text{ mA}$  ( $R < 5\Omega$ ) and open circuit voltage ranging from 4 to 24V DC according to IEC/EN61557-2 and VDE 0413 part 4.

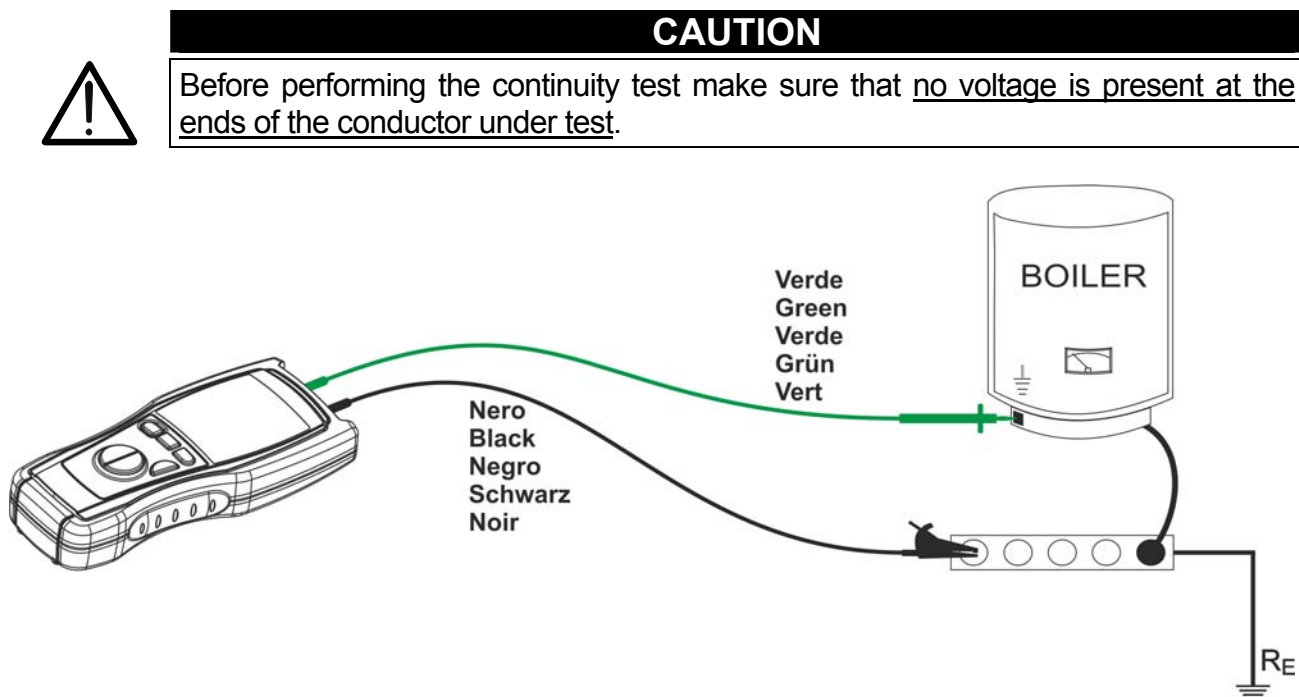

Fig. 9: Connection of the instrument's terminals during test

1. Turn on the instrument
2. Press the arrow keys to select  $\Omega 0.2A$
3. Insert the black and green cables in the corresponding input terminals of the instrument
4. If the cable length is not sufficient to perform the test, extend the black one
5. If necessary insert the croco clips on the test probes
6. If the measuring cables being used have not been calibrated, first calibrate them as described in § 4.12.1
7. Connect the instrument's terminals to the ends of the conductor on which the continuit  test must be performed (see Fig. 9)
8. Press **GO** to perform the measurement



CAUTION

The message "**Measuring**" on the display means that the instrument is measuring. During this phase never disconnect test leads. Connect the instrument just BEFORE measuring and do not change connections while the message "**Measuring**" is present on the display

9. The continuity test is performed by supplying a current higher than 200mA if the resistance value is lower than  $5\Omega$  (including the cable resistance stored as offset after calibration). For higher resistance values the instrument performs the test with decreasing current

10. At the end of the test, if it has been possible to generate at least 200mA (not particularly high resistance value), the instrument emits a double sound to signal the positive outcome of the test. The screen beside is displayed

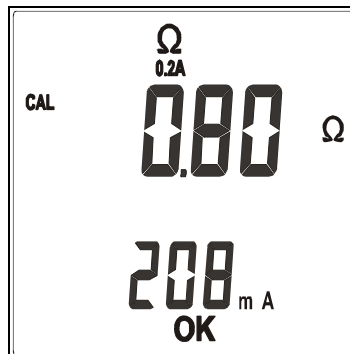

Resistance value

Test current value

11. At the end of the test, if it has not been possible to generate 200mA due to the high resistance value, the instrument emits a prolonged sound to signal the negative outcome of the test. The screen beside is displayed

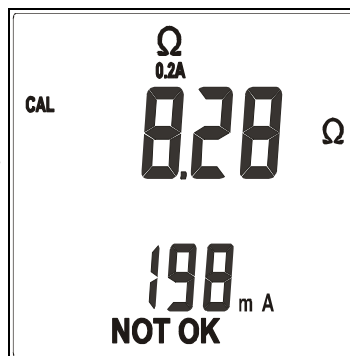

Resistance value

Test current value

#### 4.12.1. "CAL" mode

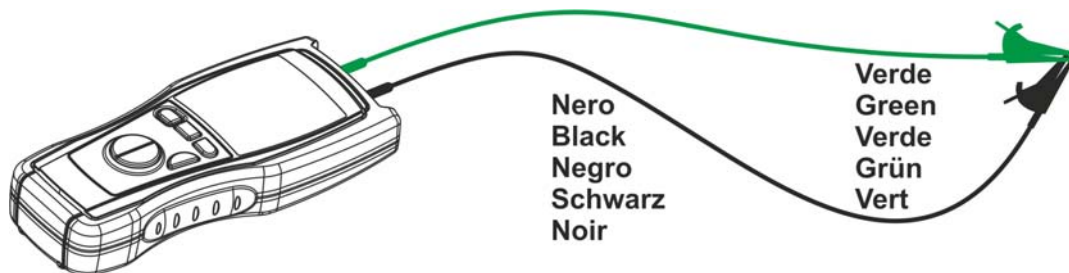

Fig. 10: Connection of the instrument's terminals during calibration procedure

1. By pressing **MODE/PEAK** select **CAL**
2. Any addition or replacement of cables, extensions and croco clips nullify the previous calibration and make necessary a new calibration before performing further measurements. Therefore the instrument must be calibrated in the same conditions at which it will operate during measurements
3. Short-circuit the cable ends with each other as shown in Fig. 10 making sure that the metallic parts of test probes and crocodiles are in good touch
4. Press **GO** to start the calibration procedure



### CAUTION

The message “**Measuring**” on the display means that the instrument is measuring. During this phase never disconnect test leads.

5. The instrument performs the calibration of cables with resistance lower than  $5\Omega$

6. At the end of the test the measured value is stored by the instrument and used as OFFSET, which means it's deducted from all continuity tests performed) for all further measurements until a new calibration is made.

The instrument emits a double sound to signal the positive outcome of the calibration procedure and displays a screen similar to this for 2 seconds. Then, the default screen corresponding to the  $\Omega$  0.2A test is displayed

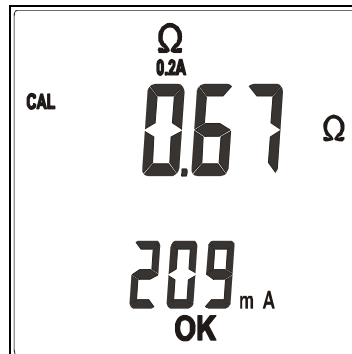

CAL message: it means that the instrument has been calibrated. This symbol remains displayed during any further measurement even in case the instrument is turned off and on

Current supplied by the instrument during calibration procedure

7. If the value measured during the calibration phase is higher than  $5\Omega$  the instrument interruptus the calibration, removes the offset value previously stored and does not display the CAL symbol until the next positive calibration. The instrument emits a prolonged sound to signal the negative outcome of the calibration and displays a screen similar to this for 2 seconds. Then, the default screen related to the  $\Omega$  0.2A test is displayed. This method can be used to nullify the last calibration performed

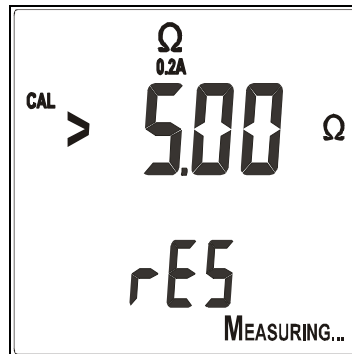

#### 4.12.2. Anomalous cases which may occur during $\Omega$ 0.2A tests

1. If the following condition occur:

$$R_{\text{MEASURED}} - R_{\text{CALIBRATION}} < -0.02\Omega$$

the instrument displays the screen beside and emits a prolonged sound to signal the anomalous situation



2. If the voltage present at the terminals is higher than 10V the instrument does not perform the test and emits a prolonged sound to signal the anomalous situation. The screen beside is displayed for 5 seconds, after which the instrument displays the default value related to the  $\Omega$  0.2A test

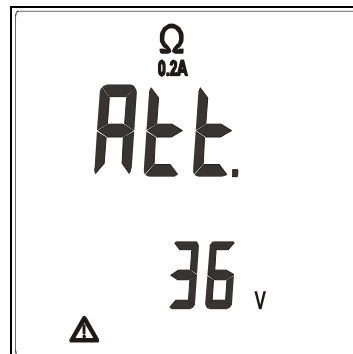

Input voltage

3. If the resistance value is higher than the full scale the instrument emits a prolonged sound to signal the anomalous situation. A screen similar to this is displayed. The same message may also mean that measuring cables are disconnected or open



4. The instrument displays the CAUTION symbol with the "OK" message when:

- The instrument is operating in a critical situation as for example in presence of overvoltages
- The instrument cannot guarantee the measuring uncertainty lower than 30% of the reading, according to EN61557-1

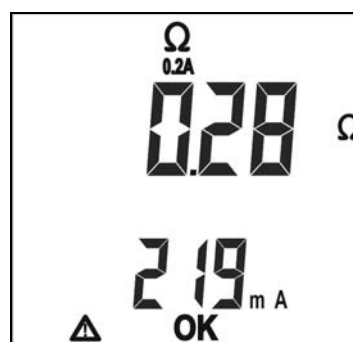

#### 4.13. $M\Omega$ : INSULATION MEASURE (M72, M74, M75)

The measurement is performed according to IEC/EN61557-2 and VDE 0413 part 1.

### CAUTION



- Before performing the insulation test make sure that the circuit under test is not energized and all relative loads are disconnected.
- The insulation measurement requires particular care and attention to avoid providing wrong test results and causing damages to third parties.
- Before the insulation test prepare the plant adequately by disconnecting everything must not be tested. During the insulation test continuously make sure that the applied voltage is not accessible to third parties.
- A measurement with a cable disconnected by mistake may provide a good result also in presence of a faulty insulation. It's necessary to take all possible cares to avoid that. Once prepared the plant and connected the measuring cables, make sure that they are correctly connected. In case of doubt, before performing an insulation test, perform a  $\Omega$  0.2A measurement by short-circuiting the cables under test at a point of the plant which is as far as possible from the measuring clips. Remove the short circuit before performing the insulation test.

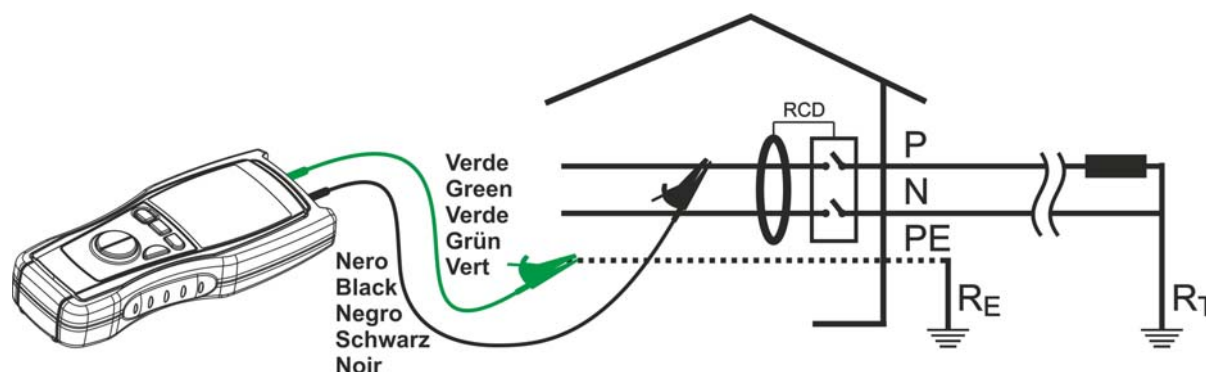

Fig. 11: Connection of the instrument's terminals during  $M\Omega$  test

1. Turn on the instrument
2. Press the arrow keys to select  $M\Omega$ . Select test voltage pressing **MODE/PEAK** key between **250** or **500VDC**. Set the value of minimum limit threshold (see § 4.5)
3. Insert the black and green cables in the corresponding input terminals of the instrument. If the cable length is not sufficient for the measurement extend the black one with an adequately insulated cable, as its insulation is in parallel to the resistance to be measured. It must be suspended and not laid to earth and all supports must be of insulated material
4. If necessary insert the croco clips on the test probes
5. Disconnect the circuit or the part of plant under test from power and all eventual loads
6. Connect the instrument's terminals to the end of the conductors on which the insulation test must be performed (see Fig. 11)
7. Press **GO** to start the measurement

**CAUTION**

The message “**Measuring**” on the display means that the instrument is measuring or discharging eventual capacitors. During this phase never disconnect nor touch test leads.

8. At the end of the test, before giving the result of the measurement, the instrument automatically discharge eventual capacitors and parasite capacitances present among the conductors involved in the measurement

9. At the end of the test, if the resistance value is higher than the minimum limit threshold (see § 4.5), the instrument emits a double sound to signal the positive outcome of the test. A screen similar to this is displayed

$M\Omega$ <b>860</b> $M\Omega$  <b>542</b> $V$ <b>OK</b>	Resistance value
	Test voltage value

10. At the end of the test, if the resistance value is higher than  $999M\Omega$ , so higher than the full scale, the instrument emits a double sound to signal the positive outcome of the test. A screen similar to this is displayed. Note! An insulation value higher than  $999M\Omega$  is an excellent insulation value, generally much higher than the minimum requirements prescribed by Standards

$M\Omega$ <b>&gt; 999</b> $M\Omega$  <b>530</b> $V$ <b>OK</b>	Resistance value
	Test voltage value

11. At the end of the test, if the resistance value is lower than the minimum limit threshold (see § 4.5) the instrument emits a prolonged sound to signal the negative outcome of the test. A screen similar to this is displayed

$M\Omega$ <b>0.44</b> $M\Omega$  <b>387</b> $V$ <b>NOT OK</b>	Resistance value
	Test voltage value

**4.13.1. Anomalous cases which may occur during  $M\Omega$  tests**

If, during measurement, the voltage present at terminals is higher than 10V the instrument does not perform the test and emits a prolonged sound to signal the anomalous situation. The screen beside is displayed for 5 seconds after which the instrument displays the default screen related to the  $M\Omega$  test

$M\Omega$ <b>Alt.</b>  <b>38</b> $V$ 	Input voltage value
---	---------------------

#### 4.14. RCD: TESTS ON AC TYPE RCDS (M73, M74, M75)

The test is performed in compliance with EN61008, EN61009, EN60947-2 part B 4.2.4.1, VDE 0413 part 6 and IEC/EN61557-6



### CAUTION

- Testing an RCD involves the tripping of the RCD itself. Therefore, before taking this measurement, **make sure that no loads are connected to the RCD under test to avoid damaging them**
- Disconnect all loads connected to the RCD as they could add further leakage currents to those moved by the instrument, thus nullifying the test results.

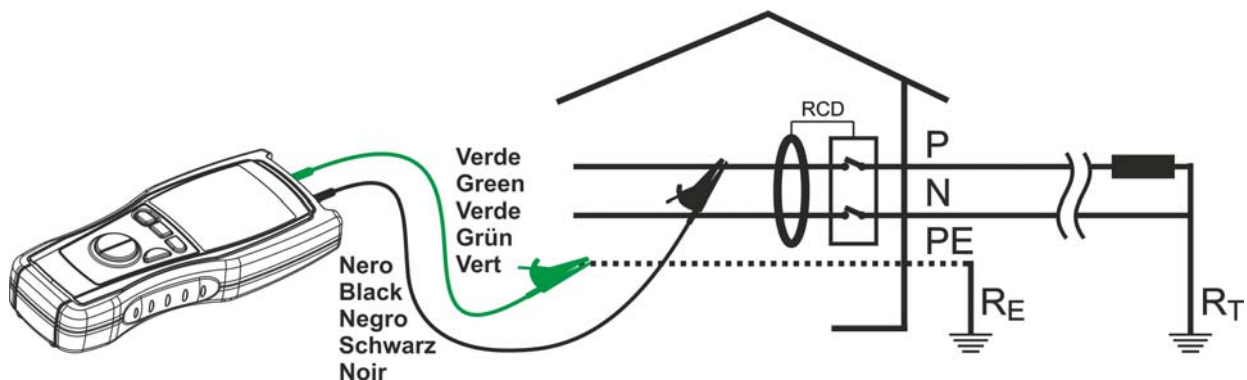

Fig. 12: Connection of the instrument's terminals during RCD test

1. Turn on the instrument
2. Press the arrow keys to select **RCD**
3. By pressing **MODE/PEAK** select the test current among the possible values **30mA**, **30mA x5**, **100mA**, **300mA** which turn cyclically at each key pressure

### CAUTION



Pay attention when setting the test current of the RCD to make sure that the correct one is selected. In case a higher current than the nominal one of the device under test is selected, the RCD would be tested at a higher current than the correct one, thus favouring a quicker tripping of the RCD itself.

As an alternative:

4. Insert the black and green cables in the corresponding input terminals of the instrument. If necessary insert the croco clips on the test probes
5. Connect the green cable to the protective conductor (earth) and the black cable to the phase conductor at the lower end of the RCD under test (Fig. 12)

Or:

4. Insert the Shuko cable in the input terminals of the instrument
5. Insert the Shuko cable in a socket at the lower end of the RCD under test



6. Keep **GO** pressed for at least one second to perform the leakage current measurement in phase with the positive semiwave of the network voltage ( $0^\circ$ ), or keep **GO** pressed for at least one second and, when the hyphens on the display start disappearing, press **GO** again to perform the measurement with the leakage current in phase with the negative semiwave of the network voltage ( $180^\circ$ )

### CAUTION



The message “**Measuring**” on the display means that the instrument is measuring. During this phase never disconnect test leads.

7. At the end of the test, if the detected tripping time is **lower than 300ms (40ms for  $I_{\Delta n}=30\text{mA} \times 5$ )**, the instrument emits a double sound to signal the positive outcome of the test and displays a screen like this

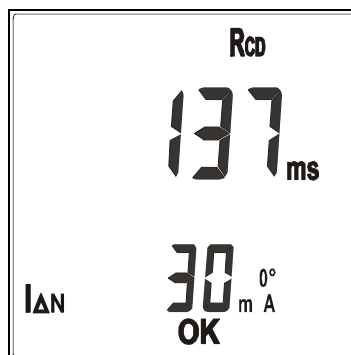

Tripping time

Test current value

8. At the end of the test, if the detected tripping time is higher than **300ms (40ms for  $I_{\Delta n}=30\text{mA} \times 5$ )**, or in case the RCD does not trip, the instrument emits a prolonged sound to signal the negative outcome of the test and displays a screen like this

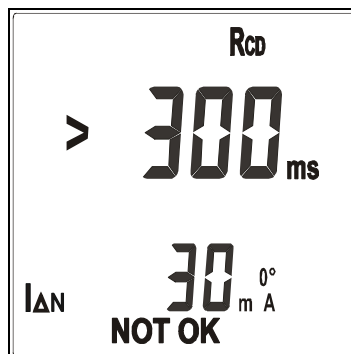

Tripping time exceeding the limit

Test current value

#### 4.14.1. Anomalous cases which may occur during RCD tests

1. If during measurement a higher input voltage than 265V is detected (for example, both cables connected to the phase conductors of a 400V three-phases plant) the instrument does not perform the test and emits a prolonged sound to signal the anomalous situation. The screen beside is displayed for 5 seconds after which the instrument displays the default screen of RCD test

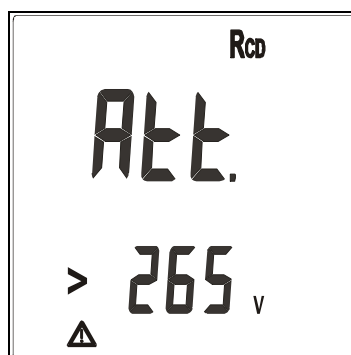

2. If during measurement a lower input voltage than 110V is detected, the instrument does not perform the test and emits a prolonged sound to signal the anomalous situation. The screen beside is displayed for 5 seconds after which the instrument displays the default screen of RCD test

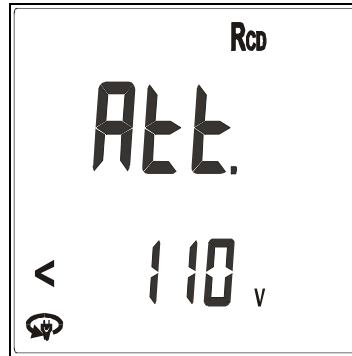

This can happen for example if the black cable is erroneously connected to the neutral conductor instead of the phase one. If a Shuko cable is used, rotate the plug and repeat the test

3. If during measurement the green probe is connected to the phase conductor and the black probe is connected to the protective conductor, the instrument does not perform the test and emits a prolonged sound to signal the anomalous situation. The screen beside is displayed for 5 seconds after which the instrument displays the default screen of RCD test

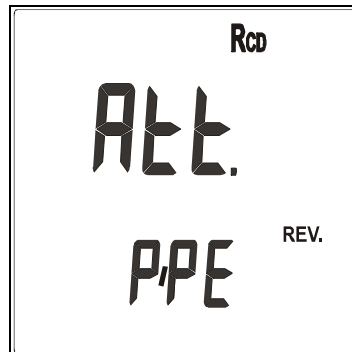

4. If during measurement an excessive contact voltage is detected (higher than 50V) the instrument does not perform the test and emits a prolonged sound to signal the anomalous situation. The screen beside is displayed for 5 seconds after which the instrument displays the default screen of RCD test

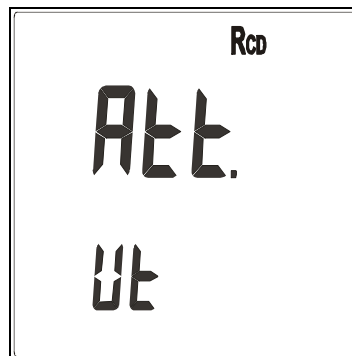

5. If during measurement an excessive earth resistance is detected, such to prevent the instrument from generating the test current, the instrument does not perform the test and emits a prolonged sound to signal the anomalous situation. The screen beside is displayed for 5 seconds after which the instrument shows the default screen related to RCD test

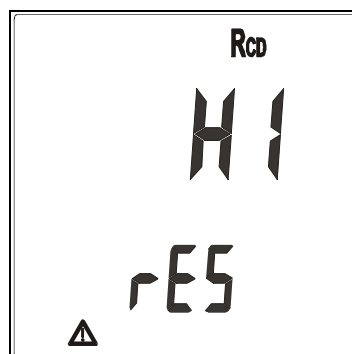

**4.15. RA  $\perp$ : MEASUREMENT OF GLOBAL EARTH RESISTANCE (M73, M74, M75)**
**CAUTION**

- **Disconnect all loads connected to the lower end of the RCD as they could introduce additional leakage currents, thus nullifying the test results.**
- Is possible to perform measurement on plants whose phase to earth rated voltage is up to 265V. Do not use the instrument on plants whose interlinked rated voltage is higher than 550V.

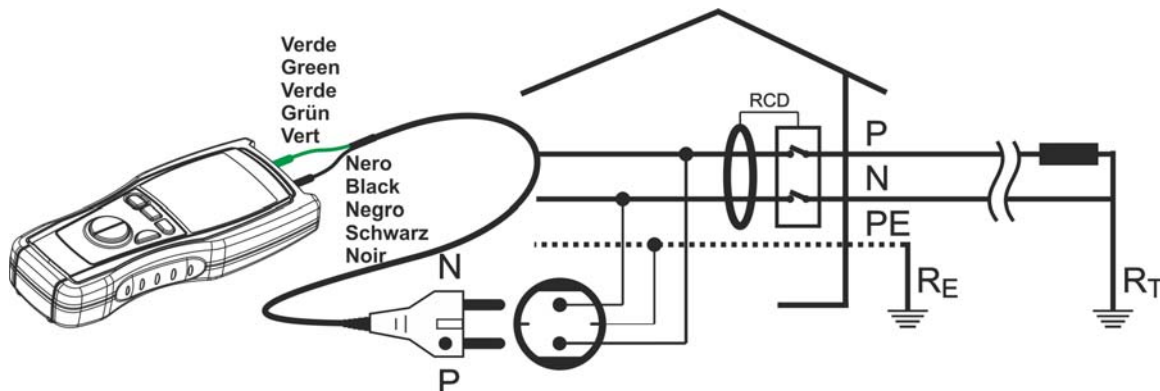

Fig. 13: Connection of the instrument's terminals during test

1. Turn on the instrument
2. Press the arrow keys to select **Ra  $\perp$**
3. By pressing **MODE/PEAK** select the test current among the possible values **15mA** and **100mA** which turn cyclically at each key pressure

**CAUTION**

If a RCD is present, select a lower current value than the nominal current value of the device. Otherwise the RCD could trip during the measurement and therefore prevent it from being executed.

4. By selecting a test current of 100mA you will get also the value of the prospective short

circuit current phase to earth, calculated according to the formula  $I_{CC} = \frac{U_N}{Z_{PE}}$  where:  
 $Z_{PE}$  is the global earth resistance value

$U_N$  is the nominal phase to earth voltage whose value is: 127V if  $100V \leq V_{measured} < 150V$   
 230V if  $150V \leq V_{measured} < 265V$

As an alternative:

5. Insert the black and green cables in the corresponding input terminals of the instrument. If necessary insert the croco clips on the test probes
6. Connect the green cable of the instrument to the protective conductor (earth) and the black cable to the phase conductor (as shown in Fig. 13)

Or:

5. Insert the Shuko cable in the input terminals of the instruments
6. Insert the Shuko cable in a power socket (as shown in Fig. 13). The picture represents the connection to power socket

7. Keep pressed **GO** for at least one second, the instrument performs the measurement

### CAUTION



The message "**Measuring**" on the display means that the instrument is measuring. During this phase never disconnect test leads.

8. At the end of the test, if the earth resistance value is lower than  $1999\Omega$ , the instrument emits a double sound and displays a screen like this reporting the value of the measured global earth resistance and the current at which the measurement has been performed

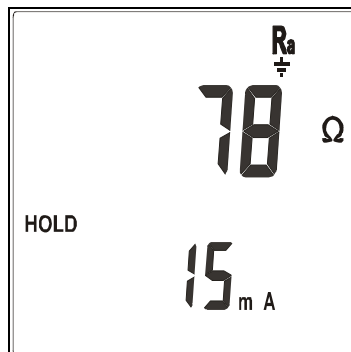

Measured value of global earth resistance

The symbol **HOLD** remains on until a new measurement can be taken

Current used during the measurement

9. If a test current of 100mA has been selected and the earth resistance value is lower than  $1999\Omega$ , by pressing **FUNC** you will display alternatively the values of the global earth resistance and the prospective short circuit current phase to earth, as well as the current at which the measurement has been performed

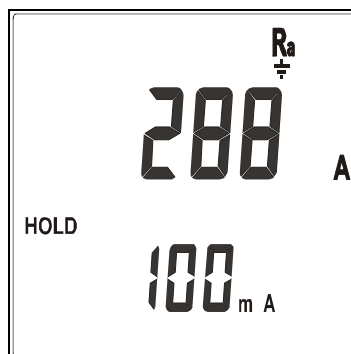

Measured value of global earth resistance

The symbol **HOLD** remains on until a new measurement can be taken

Current used during the measurement

10. At the end of the test, if the global earth resistance value is higher than  $1999\Omega$ , the instrument emits a double sound and displays a screen like this

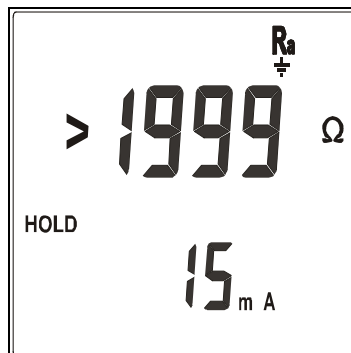

Measured value of global earth resistance higher than full scale

The symbol **HOLD** remains on until a new measurement can be taken

### CAUTION



To guarantee the correctness of measurements, a certain interval of time is necessary between a measurement and the following. During this period the symbol **HOLD** is displayed and no measurement can be taken. When the symbol **HOLD** disappears, the instrument is ready for a new measurement.

#### 4.15.1. Anomalous cases which may occur during $R_a \perp$ tests

1. If during measurement the RCD protecting the line trips, the instrument interrupts the test and emits a prolonged sound to signal the anomalous situation. The screen beside is displayed for 5 seconds after which the instrument displays the default screen of  $R_a \perp$  test



2. If during measurement a higher input voltage than 265V is detected (for example, if both cables connected to phase conductors of a 400V three-phase plant) the instrument does not perform the test and emits a prolonged sound to signal the anomalous situation. The screen beside is displayed for 5 seconds after which the instrument displays the default screen of  $R_a \perp$  test

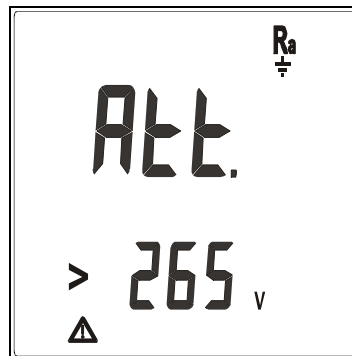

3. If during measurement a lower input voltage than 110V is detected, the instrument does not perform the test and emits a prolonged sound to signal the anomalous situation. The screen beside is displayed for 5 seconds after which the instrument displays the default screen of  $R_a \perp$  test. This can happen for example if the black cable is erroneously connected to the neutral conductor instead of the phase one. If a Shuko cable is used, rotate the plug and repeat the test

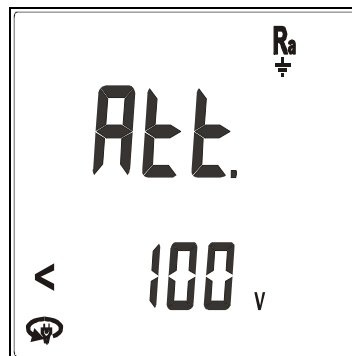

4. If during measurement an excessive contact voltage is detected (higher than 50V) the instrument does not perform the test and emits a prolonged sound to signal the anomalous situation. The screen beside is displayed for 5 seconds after which the instrument displays the default screen of Ra  $\perp$  test

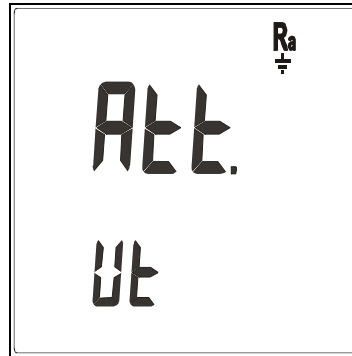

5. The instrument displays the  $\triangle$  symbol when:
- The instrument is operating in a critical situation as for example in presence of overvoltages
  - The instrument cannot guarantee the measuring uncertainty lower than 30% of the reading, according to IEC/EN61557-1

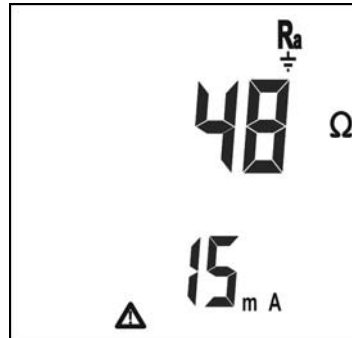

6. If during measurement the green probe is connected to the phase conductor and the black probe is connected to the protective conductor, the instrument does not perform the test and emits a prolonged sound to signal the anomalous situation. The screen beside is displayed for 5 seconds after which the instrument displays the default screen of Ra  $\perp$  test. This can happen even if the wrong connection is performed on the back side of the power socket

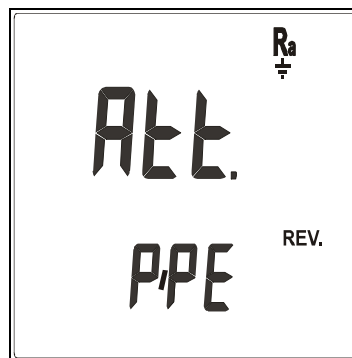

#### 4.16. AUTO: AUTOMATIC CYCLE OF MEASUREMENTS (M74, M75)

This function permits to test an electrical plant in a completely automatic way without any intervention of the operator.



### CAUTION

- Testing an RCD involves the tripping of the RCD itself. Therefore, before taking this measurement, **make sure that no loads are connected to the RCD under test to avoid damaging them**
- Disconnect all loads connected to the RCD as they could add further leakage currents to those moved by the instrument, thus nullifying the test results.

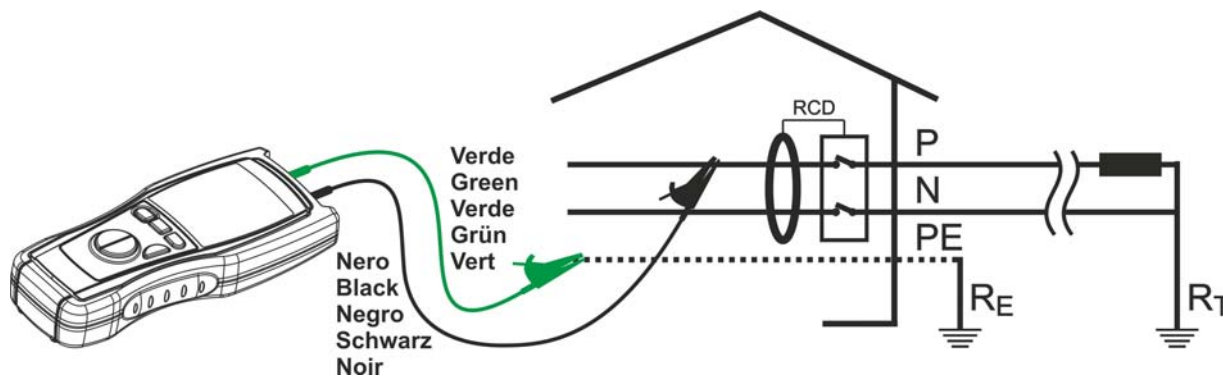

Fig. 14: Connection of the instrument's terminals during AUTO test

1. Turn on the instrument
2. Press the arrow keys to select **AUTO**
3. By pressing **MODE/PEAK** select the test current among the possible values **30mA**, **30mA x5**, **100mA**, **300mA** which turn cyclically at each key pressure

### CAUTION



Pay attention when setting the test current of the RCD to make sure that the correct one is selected. In case a higher current than the nominal one of the device under test is selected, the RCD would be tested at a higher current than the correct one, thus favouring a quicker tripping of the RCD itself.

4. Insert the black and green cables in the corresponding input terminals of the instrument. If necessary insert the alligator clips on the test probes or use the shuko cable
5. Connect the green cable to the protective conductor (earth) and the black cable to the phase conductor (Fig. 14) or insert the Shuko cable in a power socket
6. Keep **GO** pressed for at least one second, the instrument performs measurements without any intervention of the operator in the following sequence:  $R_a \stackrel{\perp}{=} (15mA)$ , RCD,  $M\Omega$  (phase to earth)

### CAUTION



The message "**Measuring**" on the display means that the instrument is measuring. During this phase never disconnect test leads.

7. During measurements, at the end of each test, the partial values are displayed for 5 seconds, then the instrument passes to the following test

8. At the end of the  $R_a \perp$  test, if the earth resistance value is lower than  $50V/I_{\Delta n}$  the instrument displays for 5 seconds a screen like this, then it passes to the following measurement. Refer to § 4.15 for further details or information regarding the negative outcome of the test or anomalous situations

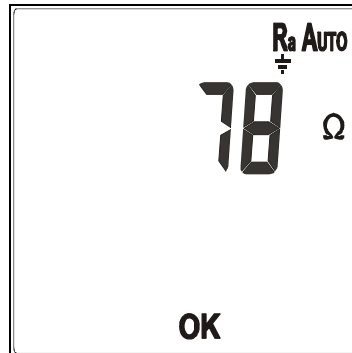

Measured value of global earth resistance

9. At the end of the test, if the detected tripping time is lower than the maximum admissible limit, the instrument displays for 5 seconds a screen like this, then it passes to the following screen. For further details or information regarding the negative outcome of the test or anomalous situations refer to § 4.14

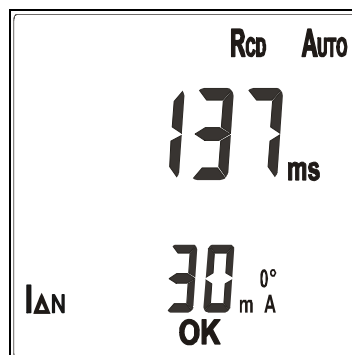

Measured value of tripping time

Value of test current

10. At the end of the  $M\Omega$  test, if the detected resistance value is higher than the minimum limit threshold (see § 4.5), the instrument displays for 5 seconds a screen like this, then it passes to the following screen. For further details or information regarding the negative outcome of the test or anomalous situations refer to § 4.13

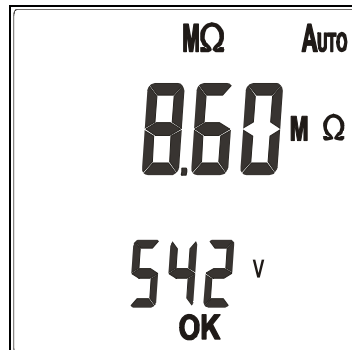

Measured value of resistance

Value of test voltage

11. At the end of the AUTO test, if all tests have a positive outcome, the instrument emits a double sound to signal the positive outcome and displays a screen like this. To display partial results press **FUNC HOLD**. The single test results are displayed cyclically by any new pressure on this key

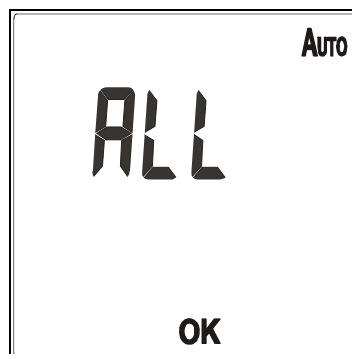



## 5. MAINTENANCE

### 5.1. GENERAL

This is a precision instrument. Strictly follow the instructions for use and storage reported in this manual to avoid any possible damage or danger during use. Do not use this tester under unfavorable conditions of high temperature or humidity. Do not expose to direct sunlight. Be sure to turn off the tester after use. If the instrument is not to be used for a long period you are recommended to remove batteries to avoid leakages of battery liquid which may damage its internal circuits.

### 5.2. BATTERY REPLACEMENT

When the low battery indication "🔋" is displayed the batteries are to be replaced.



#### CAUTION

Only skilled technicians can open the instrument and replace batteries. Before removing batteries disconnect the test leads from the input terminals to avoid electrical shocks.

1. Switch off the instrument
2. Remove test leads from the input terminals
3. Remove the battery compartment cover by using a screwdriver
4. Remove all batteries replacing them with new ones all of the same type (refer to § 6.2) respecting the polarity signs
5. Re-allocate the battery pack taking care that the part from which the black and red wires come out is positioned backwards
6. If the battery pack is re-allocated in a wrong way, the battery compartment can not be closed. In this case do not force the plastic parts, but re-position the battery pack correctly before closing
7. Replace the battery compartment cover making a pressure to close it
8. Use the appropriate battery disposal methods for your area

### 5.3. CLEANING

Use a soft dry cloth to clean the instrument. Never use wet cloths, solvents, water, etc.

### 5.4. END OF LIFE



Caution: this symbol indicates that equipment and its accessories shall be subject to a separate collection and correct disposal

## 6. TECHNICAL SPECIFICATIONS

Accuracy is indicated as [%reading + (digit number\*resolution)] at: 23°C±5°C, <70%HR.

### DC/AC TRMS Voltage

Range	Resolution	Accuracy DC	Accuracy (30 ÷ 70Hz)	Accuracy (70 ÷ 400Hz)	Input impedance
1.0 ÷ 999.9mV	0.1mV	±(0.5%rdg+2dgt)	±(1.0%rdg+2dgt)	±(2.0%rdg+2dgt)	1MΩ
1.000 ÷ 9.999V	0.001V				
10.00 ÷ 99.99V	0.01V				
100.0 ÷ 605.0V	0.1V				

MAX, MIN, AVG, PEAK, resolution: ±(5.0% rdg + 10 dgt); response time: 500ms (MAX, MIN, AVG), 1ms (PEAK)  
 Max crest factor: 3.0: V<1.0V; 1.5: V≥1.0V

### DC/AC TRMS Current (with external jaws)

Range	Resolution	Accuracy DC	Accuracy (30 ÷ 70Hz)	Accuracy (70 ÷ 400Hz)	Input impedance	Overload protection
1.0 ÷ 999.9mV	0.1mV	±(0.5%rdg+2dgt)	±(1.0% rdg + 2 dgt)	±(2.0% rdg + 2 dgt)	1MΩ	605V AC max RMS
1.000 ÷ 1.200V	0.001V					

**NOTE** The mentioned accuracy does not consider the transducer's accuracy. Please refer to its user's manual  
 MAX, MIN, AVG, PEAK, resolution: ±(5.0% rdg + 10 dgt); response time: 500ms (MAX, MIN, AVG), 1ms (PEAK)  
 Minimum input current: 1mV x transduction ratio of the clamp  
 Max crest factor: 3.0: V<1.0V; 1.5: V≥1.0V

### Frequency measurement with test leads

Range	Resolution	Accuracy	Input impedance
30.0 ÷ 199.9Hz	0.1Hz	±(0.5%rdg + 2dgt)	1MΩ
200 ÷ 400Hz	1Hz		

Input voltage: 1mV ÷ 605.0V

### Frequency measurement with jaws

Range	Resolution	Accuracy	Overload protection
30.0 ÷ 199.9Hz	0.1Hz	±(0.5%rdg + 2dgt)	605V AC max RMS
200 ÷ 400Hz	1Hz		

Input voltage: 1mV ÷ 1V

### Resistance and continuity test

Range	Resolution	Accuracy	Buzzer	Overload protection
0.00 ÷ 39.99 Ω	0.01Ω	±(1.0%rdg + 5dgt)	R<40Ω	605V AC max RMS for 1 minute
40.0 ÷ 399.9 Ω	0.1Ω			
400 ÷ 3999 Ω	1Ω			
4.00 ÷ 39.99 kΩ	10Ω			

### Phase sequence and phase conformity

Measuring method	Working voltage (V)	System
1 test lead (1W)	90 ÷ 315 (Phase - Ground)	up to 315 V (Phase - Ground)
		up to 550V (Phase - Phase)
2 test leads (2W)	90 ÷ 315 (Phase - Neutral)	up to 315 V (Phase - Neutral)
		up to 550V (Phase - Phase) (*)

Max crest factor: 1.5 ; Frequency range: 45 ÷ 65 Hz

(\*) The two-wire measurement can be performed also phase to phase in plants without neutral, even with one phase to earth, but always with phase to phase voltage up to 550V

### Ω 0.2A: Continuity with 200mA (M72, M74, M75)

Range	Resolution	Accuracy	Overload protection
0.00 ÷ 19.99Ω	0.01Ω	±(5.0% rdg + 3 dgt)	605V max RMS
20.0 ÷ 99.9Ω	0.1		

Test current: >200mA DC up to 5Ω (measuring cables resistance included)

Accuracy of current measurement: 1mA

Open circuit voltage: 4 < V<sub>0</sub> < 24V

**MΩ: Insulation resistance 250, 500VDC (M72, M74, M75)**

Range	Resolution	Accuracy	Overload protection
0.00 ÷ 19.99MΩ	0.01MΩ	±(5.0% rdg + 2 dgt)	605V max RMS
20.0 ÷ 199.9MΩ	0.1MΩ	±(5.0% rdg + 2 dgt)	
200 ÷ 999MΩ(*)	1MΩ	±(10.0% rdg + 2 dgt)	

(\*) For 500VDC test voltage. For 250VDC test voltage the range is: 200 ÷ 499MΩ

Autorange

Open circuit voltage:  $<1.3 \times V_0$

Accuracy of nominal voltage: -0% +10%

Short circuit current:  $<3.0\text{mA}$

Nominal testing current: 1mA @ 1KΩ x V (1mA @ 500KΩ)

**RCD: test on RCD devices AC type (M73, M74, M75)**

Range	Resolution	Accuracy	Overload protection
2 ÷ 400ms	1ms	±(2.0% rdg + 2 dgt)	605V max RMS

Phase to ground voltage: 110 ÷ 265V

Test currents: 30mA, 30mA x 5, 100mA, 300mA

Frequency: 50Hz ± 0.5Hz / 60Hz ± 0.5Hz

**Ra  $\frac{\perp}{\equiv}$ : Measurement of global earth resistance (M73, M74, M75)**

Test current	Range	Resolution	Accuracy	Overload protection
15mA	1 ÷ 1999Ω	1Ω	±(5% rdg + 2 dgt)	605V max RMS
100mA	0.1 ÷ 199.9Ω	0.1Ω	±(5% rdg + 3 dgt)	

Phase to ground voltage: 110 ÷ 265V; Frequency: 50Hz ± 0.5Hz / 60Hz ± 0.5Hz

Nominal voltage used for the calculation of the prospective short circuit current:

127V if  $100\text{V} \leq V_{\text{measured}} < 150\text{V}$   
230V if  $150\text{V} \leq V_{\text{measured}} < 265\text{V}$

**Wire mapping (M75)**

Length of the cable: 1 ÷ 100m

Number of remote units: max 8 units

Detected errors: OPEN Pairs, REVERSED pairs, SHORT pairs, SPLIT pairs, CROSSED pairs, MISWIRING

According to the norm: TIA568B

**CAUTION**

In all measurements the instrument displays the  symbol when:

- The instrument is operating in a critical situation as for example in presence of overvoltages.
- The instrument cannot guarantee the measuring uncertainty lower than 30% of the reading, according to IEC/EN61557-1.

## 6.1. REFERENCE GUIDELINES

Safety:	IEC/EN61010-1, IEC/EN61557-1-2-3-4-6-7
Insulation:	double insulation
Pollution level:	2
Measurement category:	CAT III 550V (phase to earth, phase to phase)
Maximum height of use:	2000m ; (6562ft)
LAN test	TIA568B

## 6.2. GENERAL SPECIFICATIONS



### Electrical features

Conversion:	ADC 16 bit, TRMS – True Root Mean Square
Measuring rate:	64 times per second
Display refreshing rate:	2 times per second

### Mechanical features

Dimensions (L x W x H):	240 x 100 x 45mm ; (9 x 4 x 2in)
Weight (batteries included):	630g ; (22ounces)

### Power supply

Battery type:	4x1.5V batteries type AA LR6 MN 1500
Low battery indication:	symbol "  " is displayed
Battery life:	Multimeter: About 90 hours
	⊙: > 1000 tests
	LAN: > 1000 tests
	Ω 0.2A: > 1000 tests @ 1Ω
	MΩ: > 1000 tests @ 480kΩ (500VDC)
	RCD: > 1000 tests
	Ra  : > 1000 tests
	AUTO: > 1000 tests

### Display

Features:	4 LCD with max. reading 9999 counts + symbol and decimal point
-----------	--

## 6.3. ENVIRONMENT

### 6.3.1. Environmental conditions

Reference temperature:	23°C ± 5°C ; (73°F ± 41°F)
Working temperature:	0°C ÷ 40 °C ; (32°F ÷ 104°F)
Relative humidity allowed:	<70%HR
Storage temperature:	-10 ÷ 60 °C ; (14°F ÷ 140°F)
Storage humidity:	<70%HR

**This instrument complies with the requirements of the European Low Voltage Directive 2006/95/CE (LVD) and EMC Directive 2004/108/CE**

## 6.4. ACCESSORIES

Please see enclosed packing list.

## 7. SERVICE

### 7.1. WARRANTY CONDITIONS

This instrument is guaranteed against material or manufacturing defects, in accordance with general sales conditions. During the warranty period the manufacturer reserves the right to decide either to repair or replace the product.

Should you need for any reason to return back the instrument for repair or replacement take prior agreements with your local distributor. Freight charges are up to the customer. Do not forget to enclose a report describing the reasons for returning the unit as well as the detected fault.

Use only original packaging. Any damage occurred in transit due to no-original packaging will be charged anyhow to the customer.

The manufacturer will not be responsible for any damage to persons or things.

The warranty doesn't apply to the following cases:

- Repair and/or replacement of accessories and batteries (not covered by warranty)
- Repairs made necessary due to improper use (including adaptation to particular applications not foreseen in the instructions manual) or improper combination with incompatible accessories or equipment
- Repairs made necessary due to improper shipping material causing damages in transit
- Repairs made necessary due to previous attempts for repair carried out by unskilled or unauthorized personnel
- Instruments for whatever reason modified by the customer himself without explicit authorization of our Technical Dept
- Use not provided by the instrument's specifications or in the instruction manual.

The contents of this manual may not be duplicated in any form whatsoever without the manufacturer's authorization.

**Our products are patented and our logotypes registered. We reserve the right to modify specifications and prices in view of technological improvements or developments which might be necessary.**

### 7.2. AFTER-SALE SERVICE

Shouldn't the instrument work properly, before contacting your distributor make sure that batteries are correctly installed and working, check the test leads and replace them if necessary. Make sure that your operating procedure corresponds to the one described in this manual.

Should you need for any reason to return back the instrument for repair or replacement take prior agreements with the local distributor from whom you bought it. Do not forget to enclose a report describing the reasons for returning (detected fault). Use only original packaging. Any damage occurred in transit due to non original packaging will be charged anyhow to the customer.

The manufacturer will not be responsible for any damage to persons or things.







Via della Boaria 40  
48018 – Faenza (RA) - Italy  
Tel: +39-0546-621002 (4 linee r.a.)  
Fax: +39-0546-621144  
email: [ht@htitalia.it](mailto:ht@htitalia.it)  
Web: [www.ht-instruments.com](http://www.ht-instruments.com)