



Installation Guide for the

## **ConferenceSHOT FX**

USB 3.0 Fixed Camera

Document 411-0015-31 Rev A  
October 2017

**Touchboards**

Call Us 1.866.942.6273

# Contents

Overview .....	1
What's in this Guide .....	1
Features .....	1
Unpacking the Camera .....	2
A Quick Look at the Camera .....	3
Back of the Camera .....	3
Switch Settings .....	4
Installation .....	5
Before You Install the Camera .....	5
Don't Void Your Warranty! .....	5
Cabling Notes .....	5
Installing the Wall Mount .....	6
About Ceiling-Mounted Cameras .....	6
Installing the Camera .....	7
Basic Connections .....	8
Powering Up the Camera .....	8
Status Light .....	8
Next Steps .....	9
Operation, Storage, and Care .....	9
Compliance Statements and Declarations of Conformity .....	10
FCC Part 15 Compliance .....	10
ICES-003 Compliance .....	10
European Compliance .....	11
Warranty Information .....	12
Index .....	13

## Overview

This guide covers the ConferenceSHOT FX USB 3.0 fixed camera, worldwide part numbers 999-20000-000 (black) and 999-20000-000W (white).



## What's in this Guide

This guide covers:

- Unpacking the camera
- Tips for a successful installation
- Instructions for installing the camera mount
- Information on connecting and mounting the camera
- Camera power-on

Complete product information is available in the **Integrator's Complete Guide to the ConferenceSHOT FX USB 3.0 Fixed Camera**.

## Features

- Fixed USB 3.0 camera for small to medium conference rooms
- 2 Megapixel, native 1080p/60 (full HD) image sensor
- 3x optical zoom, horizontal field of view of 88°
- Simultaneous uncompressed USB 3.0 and IP (H.264) streaming outputs at resolutions up to 1080p/60
- Selectable IP stream resolution; USB stream resolution auto-negotiated with conferencing client
- Universal Video Class (UVC) drivers supported in Windows®, Mac® OS, and Linux operating systems, compatible with most UC conferencing applications
- Presenter-friendly IR remote control
- Integration-ready Telnet or serial RS-232 control
- Full administrative control via web interface; manage remotely while monitoring the stream separately.

## Unpacking the Camera

Make sure you received all the items you expected.

**Caution:**

*Use the power supply shipped with the camera. Using a different power supply may create an unsafe operating condition or damage the camera, and will void the warranty.*

**Caution**

*Always support the camera's body when picking it up. Lifting the camera by its head or mounting arm will damage it.*



ConferenceSHOT FX camera, black, part number 999-20000-000

The box should contain one of each item listed here:

- Camera, part number 998-20000-000
- Thin Profile Wall Mount with mounting hardware, black
- 12 VDC, 1.5 Amp switching power supply with AC plug adapters
- USB 3.0 Type A to Type B cable, 6 ft. (1.8 m)
- Remote control
- Quick Start Guide



ConferenceSHOT FX camera, white, part number 999-20000-000W

The box should contain one of each item listed here:

- Camera, part number 998-20000-000W
- Thin Profile Wall Mount with mounting hardware, white
- 12 VDC, 1.5 Amp switching power supply with AC plug adapters
- USB 3.0 Type A to Type B cable, 6 ft. (1.8 m)
- Remote control
- Quick Start Guide



## A Quick Look at the Camera



- **Camera and Zoom Lens:** The ConferenceSHOT FX camera features a 3X optical zoom lens.
- **IR sensor:** Receives signals from the remote. Make sure there's nothing directly in front of the camera base, and point the remote at the camera.
- **Status light:** The multi-colored LED indicates the camera's current state, unless it has been turned off.

### Note

*The camera may be powered up and sending video even if the status light is off.*

## Back of the Camera

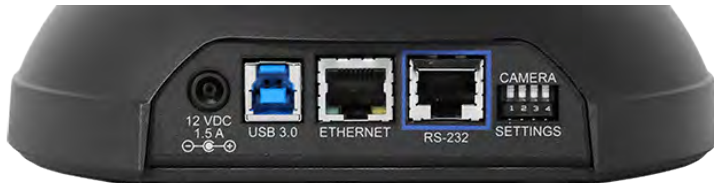

- **12 VDC, 1.5 amp power connector** – Connect only the power supply shipped with the camera
- **USB 3.0 type B video device connector** – Streams uncompressed UVC standard video
- **Ethernet RJ-45** – Connect to the network for IP streaming and camera control via web interface or Telnet
- **DIP switches** – Set IR frequency and image flip (camera is invertible)
- **RS-232 port** – Connect to a controller to manage the camera using a modified VISCA protocol

## Switch Settings

The camera uses DIP switches to determine certain camera functions.

A label on the bottom of the camera provides a quick reference for setting the switches.

*When the camera is right side up, switches are in their default positions when they are up.*

**IR Frequency Selection:** The IR Remote Commander can control up to three cameras in the same room with different IR frequencies. Use **switches 1 and 2** to select the frequency to identify the camera as camera 1, 2, or 3; then use the Camera Select buttons at the top of the remote to select the camera you want to control.

**Inverted operation:** If mounting the camera upside-down, set **switch 3** to the DOWN position: IMAGE FLIP ON.

**Switch 4** is not currently used.

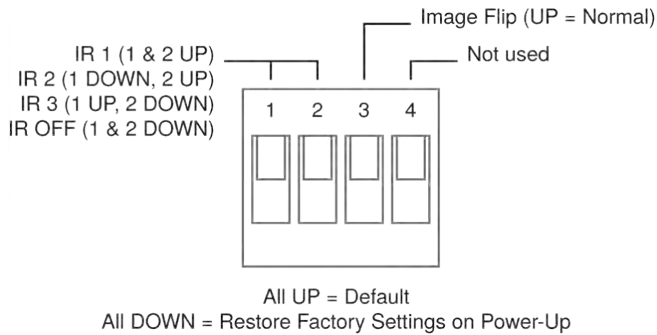

### Note

*The web interface provides additional switch settings for baud rate, status indicator behavior, and soft client compatibility.*

## Installation

This section covers siting the camera, installing the mount, and installing the camera.

### Before You Install the Camera

All ConferenceSHOT cameras include a wall mount. Other mounting options are available as well. Contact us if you don't have the camera mount you need.

- Choose a camera mounting location that will optimize camera performance. Consider camera viewing angles, lighting conditions, line-of-sight obstructions, and in-wall obstructions where the camera is to be mounted.
- Ensure that the camera can be pointed appropriately from the desired location. The camera will not perform well if it is pointed toward a light source such as a light fixture or window.
- Follow the installation instructions included with the camera mount.

### Don't Void Your Warranty!

#### **Caution**

*This product is for indoor use. Do not install it outdoors or in a humid environment without the appropriate protective enclosure. Do not allow it to come into contact with any liquid.*

*Use only the power supply included with this product. Using a different one will void the warranty, and could create unsafe operating conditions or damage the product.*

*Do not install or operate this product if it has been dropped, damaged, or exposed to liquids. If any of these things happen, return it to Vaddio for safety and functional testing.*

Learn more at [www.vaddio.com/products](http://www.vaddio.com/products).

### Cabling Notes

#### **Note**

*Use standard RJ-45 connectors and a good crimping tool. Do not use pass-through RJ-45 connectors. Poorly crimped connectors can damage the connectors on the product, cause intermittent connections, and degrade signal quality. Test cable pin-outs and continuity before connecting them.*



**Intact** – Contact fingers will make reliable contact with the cable connector



**Damaged** – Some contact fingers are bent and will NOT make reliable contact with the cable connector

#### **Pro Tip**

*Label all cables at both ends.*

## Installing the Wall Mount

You can install the camera wall mount to a 2-gang wall box or directly to the drywall.

- If you mount it to drywall, use the wall anchors provided with the wall mount.
- If you mount it to a wall box, use the cover plate screws supplied with the wall box.

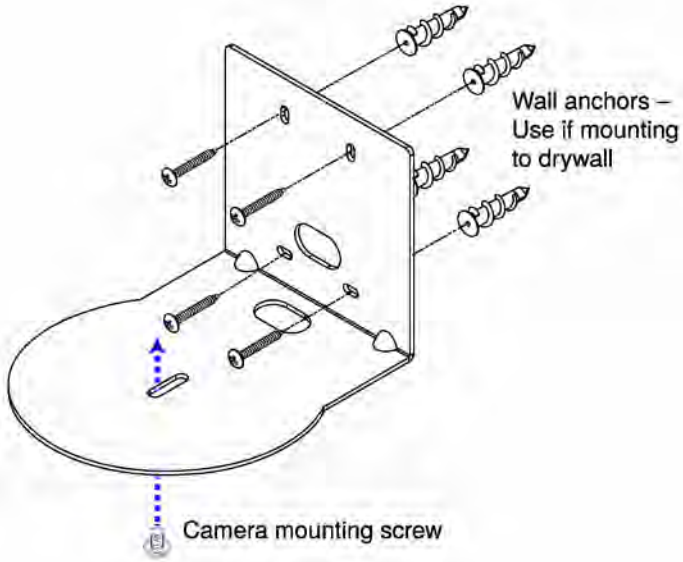

## About Ceiling-Mounted Cameras

If you use an inverted mount, the camera will need to be configured for inverted operation. See [Setting Switches in the Web Interface](#).

**Touchboards**

Call Us 1.866.942.6273



## Installing the Camera

### **Caution**

Before you start, be sure you can identify all cables correctly. Connecting a cable to the wrong port can result in equipment damage.

### **Caution:**

Check Cat-5 cables for continuity before using them. Using the wrong pin-out may damage the camera system and void the warranty. Pro tip: Label your cables.

1. Route the cables through the opening in the mounting shelf.
2. Connect the cables to the camera.

### **Caution:**

Use the power supply shipped with the camera. Using a different power supply will damage the camera and void the warranty, and may create an unsafe operating condition.

3. Place the camera on the mount.
4. Attach the camera to the mount using the 1/4"-20 x .375 mounting screw supplied with the camera.

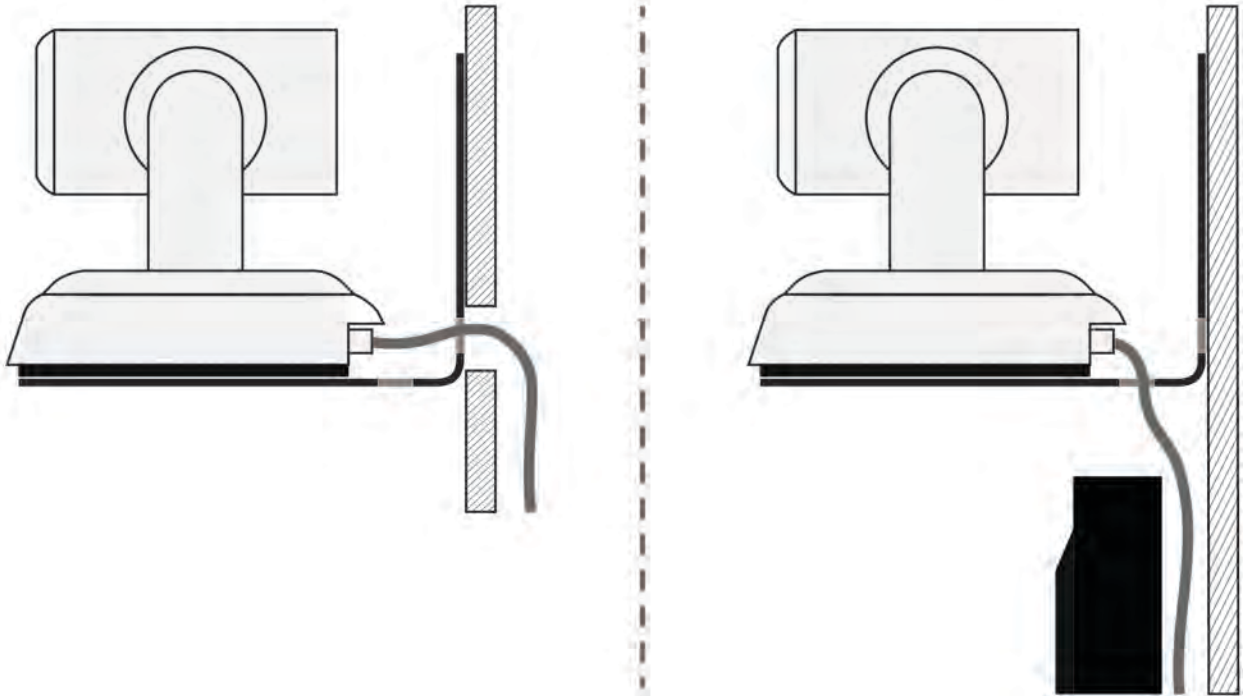

Image for illustration only; not to scale. Camera and mount details may differ.

### **Note**

This is a fixed camera. After it is powered up and sending video, it will need to be positioned by hand.

## Basic Connections

Here is an example of how the camera might be set up in a conference room. In this setup, a computer uses a unified communications conferencing application with the camera and a conference phone.

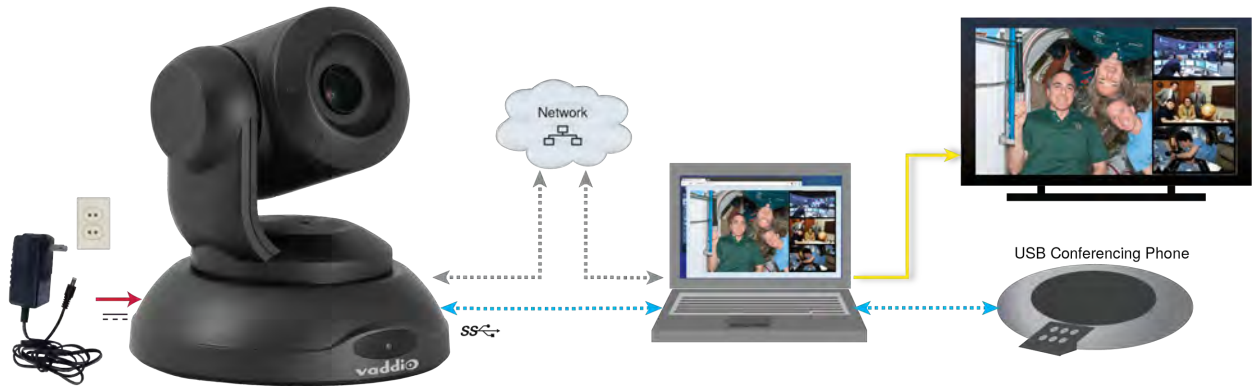

## Powering Up the Camera

Connect camera power.

The status light illuminates purple as the camera initializes. When the camera is ready and a video stream is available, the light changes to blue.

Turn and tilt the camera as needed to position it for the desired view.

## Status Light

The light in the camera's base indicates its current state.

- Blue – Camera is active
- Purple – Standby mode or booting
- Yellow – Firmware update is in progress
- Blinking blue – USB cable is disconnected
- Blinking purple – Error

### **Caution**

*Do not remove power or reset the camera while the indicator is yellow, showing a firmware update in progress. Interrupting a firmware update can make the camera unusable.*

### **Note**

*The camera may be powered up and sending video even if the status light is off.*

## Next Steps

The camera is now ready to configure and use. This information is available in the **Configuration and Administration Guide for the ConferenceSHOT FX USB 3.0 Fixed Camera**. It is also included in the **Integrator's Complete Guide to the ConferenceSHOT FX USB 3.0 Fixed Camera**.

## Operation, Storage, and Care

For smears or smudges on the product, wipe with a clean, soft cloth. Use a lens cleaner on the lens. Do not use any abrasive chemicals.

Keep this device away from food and liquids.

Do not operate or store the device under any of the following conditions:

- Temperatures above 40°C (104°F) or below 0°C (32°F)
- High humidity, condensing or wet environments
- Inclement weather
- Severe vibration
- Between converging tectonic plates
- Dry environments with an excess of static discharge

Do not attempt to take this product apart. There are no user-serviceable components inside.

## Compliance Statements and Declarations of Conformity

Compliance testing was performed to the following regulations:

FCC Part 15 (15.107, 15.109), Subpart B	Class A
ICES-003, Issue 54: 2012	Class A
EMC Directive 2004/108/EC	Class A
EN 55022: December 2010	Class A
EN 55024: November 2010	Class A
KN22 2008 (CISPR 22: 2006)	Class A
KN24 2008 (CISPR 24: 1997 + A1: 2000 + A2: 2002)	Class A
IEC 60950-1:2005 (2nd Edition); Am 1: 2009 + Am 2: 2013	Safety
EN 60950-1: 2006 + A11: 2009 + A1: 2010 + A12: 2011 + A2: 2013	Safety

### FCC Part 15 Compliance

Operation is subject to the following two conditions: (1) This device may not cause interference, and (2) This device must accept any interference including interference that may cause undesired operation of the device.



Changes or modifications not expressly approved by Vaddio can affect emission compliance and could void the user's authority to operate this equipment.

### ICES-003 Compliance

This digital apparatus does not exceed the Class A limits for radio noise emissions from digital apparatus set out in the Radio Interference Regulations of the Canadian Department of Communications.

Le présent appareil numérique n'émet pas de bruits radioélectriques dépassant les limites applicables aux appareils numériques de la classe A prescrites dans le Règlement sur le brouillage radioélectrique édicté par le ministère des Communications du Canada.

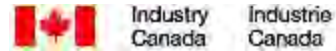

## European Compliance

This product has been evaluated for electromagnetic compatibility under the EMC Directive for Emissions and Immunity and meets the requirements for a Class A digital device. In a domestic environment this product may cause radio interference in which case the user may be required to take adequate measures.

Standard(s) To Which Conformity Is Declared:



**EMC Directive 2004/108/EC**

**EN 55022: December 2010**

**EN 55024: November 2010**

EN 61000-4-2: 1995 + Amendments A1: 1998 + A2: 2001

EN 61000-4-3: 2006 + A1: 2008

EN 61000-4-4: 2004 + Corrigendum 2006

EN 61000-4-5: 2006

EN 61000-4-6: 2009

EN 61000-4-8: 2010

EN 61000-4-11: 2004

**KN22 2008 (CISPR 22: 2006)**

**KN24 2008 (CISPR 24: 1997 + A1: 2000 + A2: 2002)**

EN 61000-4-2

EN 61000-4-3

EN 61000-4-4

EN 61000-4-5

EN 61000-4-6

EN 61000-4-8

EN 61000-4-11

**IEC 60950-1: 2005 (2nd Edition); Am 1: 2009 + Am 2: 2013**

**EN 60950-1: 2006 + A11: 2009 + A1: 2010 + A12: 2011 + A2: 2013**

Conducted and Radiated Emissions

Immunity

Electrostatic Discharge

Radiated Immunity

Electrical Fast Transients

Surge Immunity

Conducted Immunity

Power Frequency Magnetic Field

Voltage Dips, Interrupts and Fluctuations

Conducted and Radiated Emissions

IT Immunity Characteristics

Electrostatic Discharge

Radiated Immunity

Electrical Fast Transients

Surge Immunity

Conducted Immunity

Power Frequency Magnetic Field

Voltage Dips, Interrupts and Fluctuations

Safety

Safety

## Warranty Information

See Vaddio Warranty, Service and Return Policies posted on [support.vaddio.com](http://support.vaddio.com) for complete details.

**Hardware\* warranty:** Two (2) year limited warranty on all parts and labor for Vaddio manufactured products. Vaddio warrants its manufactured products against defects in materials and workmanship for a period of two years from the day of purchase, to the original purchaser, if Vaddio receives notice of such defects during the warranty. Vaddio, at its option, will repair or replace products that prove to be defective. Vaddio manufactures its hardware products from parts and components that are new or equivalent to new in accordance with industry standard practices.

**Exclusions:** The above warranty shall not apply to defects resulting from improper or inadequate maintenance by the customer, customers applied software or interfacing, unauthorized modifications or misuse, mishandling, operation outside the normal environmental specifications for the product, use of the incorrect power supply, modified power supply or improper site operation and maintenance. OEM and special order products manufactured by other companies are excluded and are covered by the manufacturer's warranty.

**Vaddio Customer Service:** Vaddio will test, repair, or replace the product or products without charge if the unit is under warranty. If the product is out of warranty, Vaddio will test then repair the product or products. The cost of parts and labor charge will be estimated by a technician and confirmed by the customer prior to repair. All components must be returned for testing as a complete unit. Vaddio will not accept responsibility for shipment after it has left the premises.

**Vaddio Technical Support:** Vaddio technicians will determine and discuss with the customer the criteria for repair costs and/or replacement. Vaddio Technical Support can be contacted by email at [support@vaddio.com](mailto:support@vaddio.com) or by phone at one of the phone numbers listed on [support.vaddio.com](http://support.vaddio.com).

**Return Material Authorization (RMA) number:** Before returning a product for repair or replacement request an RMA from Vaddio's technical support. Provide the technician with a return phone number, e-mail address, shipping address, product serial numbers and original purchase order number. Describe the reason for repairs or returns as well as the date of purchase. See the General RMA Terms and Procedures section for more information. RMAs are valid for 30 days and will be issued to Vaddio dealers only. End users must return products through Vaddio dealers. Include the assigned RMA number in all correspondence with Vaddio. Write the assigned RMA number clearly on the shipping label of the box when returning the product. All products returned for credit are subject to a restocking charge without exception. Special order product are not returnable.

**Voided warranty:** The warranty does not apply if the original serial number has been removed or if the product has been disassembled or damaged through misuse, accident, modifications, use of incorrect power supply, use of a modified power supply or unauthorized repair.

**Shipping and handling:** Vaddio will not pay for inbound shipping transportation or insurance charges or accept any responsibility for laws and ordinances from inbound transit. Vaddio will pay for outbound shipping, transportation, and insurance charges for all items under warranty but will not assume responsibility for loss and/or damage by the outbound freight carrier. If the return shipment appears damaged, retain the original boxes and packing material for inspection by the carrier. Contact your carrier immediately.

**Products not under warranty:** Payment arrangements are required before outbound shipment for all out of warranty products.

# Index

## A

anatomy of the camera 3

## C

cable connectors 3, 5  
camera ID setting (DIP switch) 4  
camera mount 2, 5-7  
    installing 6  
camera placement 5  
camera select See also camera ID setting  
    (DIP switch)  
capabilities 1  
ceiling-mounted cameras 6  
cleaning 9  
color codes for status light 8  
connection diagram 8  
connectors 3

## D

damage, preventing 2, 5  
diagram, connection 8  
DIP switches 3-4  
    location 3  
    settings 4

## E

Ethernet port 3

## I

image flip setting (DIP switch) 4  
indicator light 8  
    meaning of colors 8  
installation 6-8  
    basic connections 8  
    camera 7  
    camera mount 6  
inverted installation 6

## L

light, status indicator 8  
    meaning of colors 8  
location of the camera 5  
locations of connectors 3

## M

mount 5-7

mounting the camera 5, 7

## N

network port 3

## O

operating environment 5, 9

## P

packing list 2  
part numbers 2  
power supply 2  
precautions 2, 5  
    for operating the system 5  
product capabilities 1  
product returns and repairs 12

## R

requirements 5  
    installation 5  
    mounting 5  
RJ-45 connectors 5

## S

shelf-mounted cameras 7  
shelf, camera mount 6  
site requirements 5  
status light 8  
    meanings of colors 8  
storage environment 9  
switch location 3  
switch settings 4, 6  
    camera ID (DIP switch) 4  
    image flip (DIP switch) 4  
    image flip (soft DIP switch) 6

## T

temperature, operating and storage 9

## U

USB cable 2  
USB port 3

## V

visual parts identification 3

## W

wall mount 6  
    installing 6  
warranty 5, 12

Vaddio is a brand of Milestone AV Technologies · [www.milestone.com](http://www.milestone.com)

Phone 800.572.2011 / +1.763.971.4400 · Fax +1.763.971.4464 · Email [info@vaddio.com](mailto:info@vaddio.com)

Visit us at [support.vaddio.com](http://support.vaddio.com) for firmware updates, specifications, drawings, manuals, technical support information, and more.

Vaddio and ConferenceSHOT are trademarks or registered trademarks of Milestone AV Technologies. All other brand names or marks are used for identification purposes and are trademarks of their respective owners.

In British Columbia, Milestone AV Technologies ULC carries on business as MAVT Milestone AV Technologies ULC.

©2017 Milestone AV Technologies

# Touchboards

Call Us 1.866.942.6273

# vaddio®