



VADDIO™ CLEARVIEW™ HD-20SE QUSB SYSTEM

ClearVIEW HD-20SE High Definition, Robotic PTZ Camera featuring the Quick-Connect™ USB System Interface

Model Number 999-6989-000 (North America)

Model Number 999-6989-001 (International)

Model Number 999-6989-000AW (North America) Arctic White Camera

Model Number 999-6989-001AW (International) Arctic White Camera

Touchboards

205 Westwood Ave, Long Branch, NJ 07740

Phone: 866-94 BOARDS (26273) / (732)-222-1511

Fax: (732)-222-7088 | E-mail: sales@touchboards.com



Quick-Connect USB System Interface

Featuring USB 2.0 or H.264 Streaming, HDMI and YPbPr Outputs

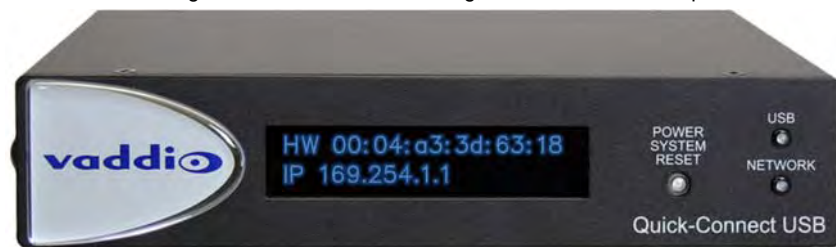



TABLE OF CONTENTS

- Overview 4
- Unpacking: 5
- Anatomy of the ClearVIEW HD-20se HD PTZ Camera 6
 - Image: Front View ClearVIEW HD-20se 6
 - Image: Rear View ClearVIEW HD-20SE Connectors 7
- Anatomy of the Quick-Connect USB Interface 8
 - Image: Front Panel with Feature Call-outs..... 8
 - Image: Rear Panel with Feature Call-outs 9
 - Table: Quick Connect USB Rear Panel DIP Switch Settings 9
- Basic Application Diagram..... 10
 - Diagram: ClearVIEW HD-20se QUSB in UC Conferencing Application 10
- First Time Set-up with the ClearVIEW HD-20se QUSB System 11
 - Image: ClearVIEW HD-20SE Rear Panel Connections 11
 - Drawing: Dip Switch and Resolution Label on the Bottom of the HD-20SE 11
- Installation Procedures 12
 - Installation Basics: 12
 - General Installation Instructions for the CONCEAL Wall Mounting System:..... 12
- Quick-Connect USB Installation Instructions..... 14
 - Controlling the Quick-Connect USB..... 14
 - Quick-Connect USB Details 14
- Controlling the Camera..... 15
 - IR Remote Commander 15
 - Telnet Control of the Camera through the Quick-Connect USB 15
- Quick-Connect USB Software Compatibility 16
 - Table: Supported UVC Resolutions 16
- Quick-Connect USB Internal Web Pages and Control 17
 - DHCP IP Set-up (Dynamic Host Configuration Protocol) 17
 - Static IP Set-up: 17
 - Quick-Connect USB Web Pages Tour:..... 17
 - Screen Shot: Login 17
 - Screen Shot: User Menu - Camera Control Page..... 18
 - Screen Shot: Admin login from the Camera Control Page 19
 - Screen Shot: Admin Menu - Camera Settings 20
 - Screen Shot: Admin Menu - Room Labels..... 21
 - Screen Shot: Admin Menu - USB 2.0 or IP Streaming Mode Page 22
 - Screen Shot: Admin Menu - DHCP Network Configuration 23
 - Screen Shot: Admin Menu - Static IP Configuration 23
 - Screen Shot: Admin Menu - Security 24
 - Screen Shot: Admin Menu - Diagnostics 24
 - Screen Shot: Admin Menu - System Menu 25
 - Screen Shot: Admin Menu - Update Confirmation 25



Screen Shot: Admin Menu - Update in Progress 26

Screen Shot: Admin Menu - HELP 26

General Specifications:..... 27

Compliance and CE Declaration of Conformity - ClearVIEW HD-20se 28

Compliance and CE Declaration of Conformity - Quick-Connect USB Interface 29

Warranty Information 30

Appendix 1: YPbPr Video Pin-Out for the HD-20se Camera 31

 EZ-POWER VIDEO RJ-45 Connector Pin-outs 31

 Drawing: ClearVIEW HD-20SE Dimensions 31

Appendix 1: Pin-outs for EZ-Power Video Cameras and Quick-Connect USB..... 32

 Table: EZ-POWER VIDEO RJ-45 Connector Pin-outs 32

 Table: Camera RS-232 Port..... 32

 Table: Quick-Connect USB DE-15 Pin-Output (Analog Component YPbPr)..... 32

Communication Specification 33

 HD-20se Command List (1/2)..... 33

 HD-20se Command List (2/2)..... 34

 HD-20se Inquiry List (1/1) 35

 Table: HD-20SE OSD Menu Structure..... 36

OVERVIEW:

The amazing ClearVIEW HD-20SE HD PTZ Camera quite literally combines all of the best features of the ClearVIEW HD-18, HD-19 and HD-20 HD PTZ cameras into ONE! The innovation of the HD-18 EZCamera™ Cat-5 interfaces, the low light capability of the HD-19 and the FULL HD performance of the HD-20 are all represented, and improved upon with the ClearVIEW HD-20SE. The ClearVIEW HD-20SE is clearly the best ClearVIEW ever, and here's why.

The HD-20SE is a native 1080p/60 camera using the latest 1/2.8-Type Exmor® high-speed, low noise CMOS image sensor technology with 2.38 Megapixels (total) and 2.14 Megapixels (effective). The ISP (image signal processor) is off-the-hook, not only providing fast, razor-sharp auto-focus routines with incredible detail, realistic textures and vivid colors, it also has an impressive low-light performance of 0.3 Lux (color) and 0.03 Lux (B/W). The lens is a 20X optical zoom multi-element glass lens with an impressive horizontal field of view of 63° on the wide end to 3.47° on the tele end. The outputs are simultaneous HDMI, YPbPr and HSDS™ (differential video for use with Quick-Connect™ Interfaces) and supports both drop frame and non-drop frame HD video resolutions of 1080p/60/59.94/50/30/25, 1080i/60/59.94/50 and 720p/60/59.94/50.



So to recap, latest technology, awesome ISP, superb low-light performance, powerful yet wide angle lens, lots and lots of video outs, drop and non-drop frame video, Full HD and there's more!

The QUSB Systems pair the Quick-Connect USB with the HD-20SE camera to create a very powerful and flexible system. These robust systems uses the Vaddio EZCamera™ Cabling system and uses two Cat-5/5e/6 cables to provide power, return video and extends RS-232 control signaling to the camera up to a distance of 100' (30.48m).

The Quick-Connect USB rear panel includes the USB 2.0 connection and the Ethernet 10/100 connection to provide for USB 2.0 streaming or IP video streaming and IP control. The USB 2.0 uses the standard UVC (Universal Video Class) drivers built-in to the OS of the computer, which means that no pesky programs or additional drivers and the associated headaches are required. Any compatible UC client using UVC drivers can be used (see compatible UC program list). The system also streams IP video (H.264) and supports both RTSP and HLS (HTTP Live Streaming, Apple's variant on HTTP streaming). An embedded web server provides for browser-based access of the HD-22/30 robotic camera controls, camera presets and rudimentary CCU functions (color and shading/painting controls) as well as the video configuration web pages. Analog (YPbPr) and HDMI video outputs are also included and output the same video resolution that is sent from the camera simultaneously. The USB and IP resolutions are independent from the standard HD video outputs.

The ClearVIEW HD-20SE QUSB system is an exceptional value and a remarkable camera for even the most demanding HD video applications including House of Worship productions, pro A/V system integration, distance learning classrooms, live events, IMAG systems, UC conferencing applications, videoconferencing, distance learning and lecture capture. To top it all off, the ClearVIEW HD-20SE cameras are available in black or arctic white and are made in the USA.

Intended Use:

Before operating the device, please read the entire manual thoroughly. The system was designed, built and tested for use indoors with the power supply provided. The use of a power supply other than the one provided or outdoor operation has not been tested and could damage the device and/or create a potentially unsafe operating condition.

Important Safeguards:

Read and understand all instructions before using. Do not operate any device if it has been dropped or damaged. In this case, a Vaddio technician must examine the product before operating. To reduce the risk of electric shock, do not immerse in water or other liquids and avoid extremely humid conditions.



Use only the power supply provided with the system. Use of any unauthorized power supply will void all warranties.



Please do not use "pass-thru" type RJ-45 connectors. These pass-thru type connectors do not work well for professional installations and can be the cause of intermittent connections which can result in the RS-232 control line failing and locking up, and/or compromising the HSDS (high speed differential) signals. For best results please use standard RJ-45 connectors and test all cables for proper pin-outs prior to use and connection to Vaddio product.

Save These Instructions:

The information contained in this manual will help install and operate your product. If these instructions are misplaced, Vaddio keeps copies of Specifications, Installation and User Guides and most pertinent product drawings for the Vaddio product line on the Vaddio website. These documents can be downloaded from support.vaddio.com free of charge.

UNPACKING:

Carefully remove the product and all of the included parts from the packaging. Identify the following parts for each camera:

ClearVIEW HD-20SE QUSB SYSTEM (North America):

Part Number: 999-6989-000

- One (1) ClearVIEW HD-20SE Camera (998-6980-000)
- One (1) Quick-Connect USB Interface
- One (1) 24 VDC, 2.08 Power Supply with Power Cord for North America
- One (1) Vaddio IR Remote Commander
- One (1) 6' (1.83m) USB Type-A to Type-B Cable (Black)
- One (1) EZCamera Control Adapter (RJ-45 to DE-9)
- One (1) CONCEAL Wall Mount System (not shown)
- Quick-Start Guide (1-pager)

Note: Full Manuals are downloaded from support.vaddio.com



ClearVIEW HD-20SE QUSB SYSTEM (International):

Part Number: 999-6989-001

- One (1) ClearVIEW HD-20SE Camera (998-6980-000)
- One (1) Quick-Connect USB Interface
- One (1) 24 VDC, 2.08 Power Supply
- One (1) Euro Power Cable
- One (1) UK Power Cable
- One (1) Vaddio IR Remote Commander
- One (1) 6' (1.83m) USB Type-A to Type-B Cable (Black)
- One (1) EZCamera Control Adapter (RJ-45 to DE-9)
- One (1) CONCEAL Wall Mount System (not shown)
- Quick-Start Guide (1-pager)

Note: Full Manuals are downloaded from support.vaddio.com



ClearVIEW HD-20SE QUSB SYSTEM (North America):

Part Number: 999-6989-000AW (Artic White Version)

- One (1) ClearVIEW HD-20SE Camera (998-6980-000AW)
- One (1) Quick-Connect USB Interface
- One (1) 24 VDC, 2.08 Power Supply with Power Cord for North America
- One (1) Vaddio IR Remote Commander
- One (1) 6' (1.83m) USB Type-A to Type-B Cable (Black)
- One (1) EZCamera Control Adapter (RJ-45 to DB-9)
- One (1) CONCEAL Wall Mount System in AW (not shown)
- Quick-Start Guide (1-pager)

Note: Full Manuals are downloaded from support.vaddio.com



ClearVIEW HD-20SE QUSB SYSTEM (International):

Part Number: 999-6989-001AW (Artic White Version)

- One (1) ClearVIEW HD-20SE Camera (998-6980-000AW)
- One (1) Quick-Connect USB Interface
- One (1) 24 VDC, 2.08 Power Supply
- One (1) Euro Power Cable
- One (1) UK Power Cable
- One (1) Vaddio IR Remote Commander
- One (1) 6' (1.83m) USB Type-A to Type-B Cable (Black)
- One (1) EZCamera Control Adapter (RJ-45 to DB-9)
- One (1) CONCEAL Wall Mount System in AW (not shown)
- Quick-Start Guide (1-pager)

Note: Full Manuals are downloaded from support.vaddio.com



International Systems include Euro and UK Power Cords



ANATOMY OF THE CLEARVIEW HD-20SE HD PTZ CAMERA

Image: Front View ClearVIEW HD-20SE



1) Camera and Zoom Lens:

The 20X optical zoom lens is built around a (1/2.8 Type) high-speed, low-noise Exmor CMOS image sensor with a total of 2.38 total megapixels for precise HD video image acquisition.

2) Red Tally Light:

A red tally light is illuminated when the camera receives a command from an external control system.

3) IR Sensors:

IR sensors are built into the front of the ClearVIEW HD-20SE to receive IR signals from the IR remote control supplied with the camera.

4) Blue Power Light:

A Vaddio blue LED power light is illuminated when the camera is turned on. This LED will blink when IR signals are received.

Image: Rear View ClearVIEW HD-20SE Connectors

**5) RS-232 IN & IR Out:**

The RS-232 accepts modified VISCA protocol for camera control, as well as transmits IR signaling received by the IR receivers, which can be transmitted to third party devices (color coded blue).

6) Dip Switch Settings:

Settings for IR remote, baud rate and image flip can be configured on these switches. See the Switch Settings page for additional information.

7) HD Video Select:

A rotary switch allows the user to choose the component HD output video resolution and format. See the Switch Settings page for additional information.

HD Resolution Note: When changing the resolution of the camera, the camera may have to be power-cycled after the change. The switcher typically will require a reboot or rescan.

8) 12 VDC Input:

Power input for the standard, ClearVIEW HD-20SE camera power supply.

9) HDMI Output:

The HDMI output feeds out HD digital video only (no copy protect or device communication is included). The HDMI output is optimized for HD video signals (seems logical).

10) YPbPr Output:

Component HD video (YPbPr) is output through the DE-15 connector. YPbPr and HDMI signals are simultaneous. Limited SD resolutions are supported.

11) EZ-Power Video Port:

This RJ-45 connector is only used with the Quick-Connect SR Interface, Quick-Connect DVI-D/HDMI SR Interface and the Quick-Connect USB Interface to supply power and return HSDS (differential) video from the camera (color coded orange)..

12) Slot for Optional Cards:

Optional slot cards can be plugged into the ClearVIEW HD-20SE camera (the HD-SDI and the EZIM CCU Slot Cards are available).

ANATOMY OF THE QUICK-CONNECT USB INTERFACE

Image: Front Panel with Feature Call-outs



1. **LCD Blue Backlit Display:**
20 x 2 Character, ODV (omnidirectional view), ABN (advanced black nematic) display with a high contrast and wide viewing angle combined with high visibility. The MAC address (labeled as "HW" for hardware) is on the top line, and the IP address (static or DHCP) is listed on the bottom line. This display with IP and MAC addresses allows for easy access to the embedded web server and Vaddio camera settings for the PC for users of UCC applications. Upon power up or power reset this display will indicate when the unit is in initialization mode.
2. **Power/ System Reset Switch:**
The System Reset switch on the front panel is a blue back lit-tactile switch that will illuminate when power is present at the rear power connector. Pressing in and holding this switch for 1.15643 seconds will restart/reinitialize the Quick-Connect USB interface.
3. **NETWORK LED:**
The green panel mount LED indicator will indicate the presence of an Ethernet connection. This LED will blink to indicate network activity. If no network connection is made, the LED will remain off.
4. **USB LED:**
The blue panel mount LED indicates the presence of a USB connection to a PC (or mac). Blinking will indicate USB activity. If no USB connection is present the LED will remain off.

Image: Rear Panel with Feature Call-outs

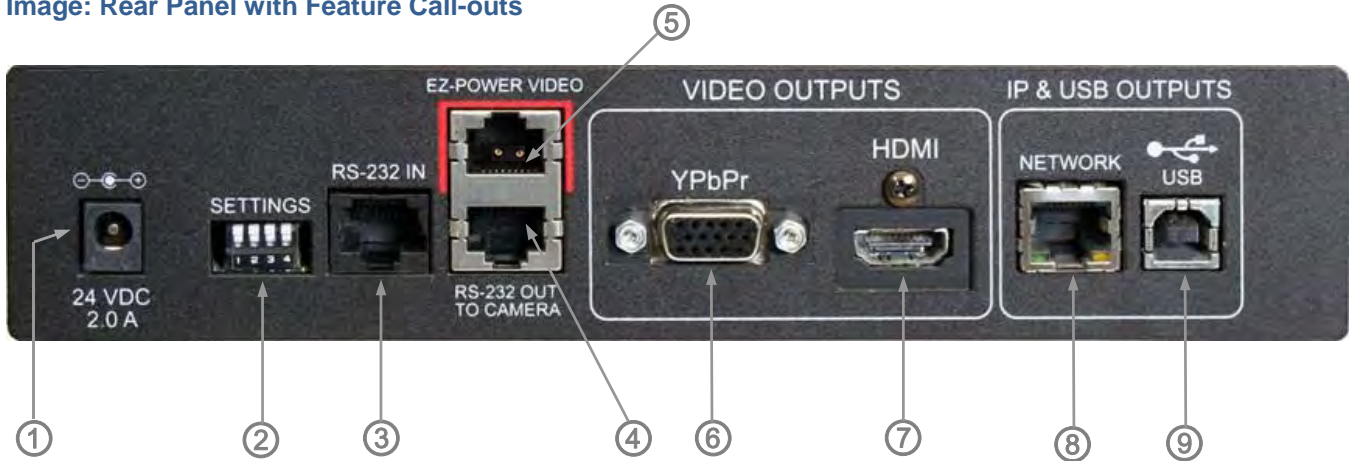

1. **Power Input:** 5.5mm OD x 2.5mm ID coaxial connector for the provided 24 VDC, 2.0 Amp switching power supply. The Quick-Connect USB Supplies Power to the attached camera.
2. **5-Position DIP Switch:** A 5-position DIP switch allows the user to choose the HD video color space (YCbCr for HDMI and sRGB color space for DVI-D) on the HDMI output, configure for updates, and restore factory defaults when cycling power.

Table: Quick Connect USB Rear Panel DIP Switch Settings

Dip Switch	Function	Default	Activation
1	Future Use	Up	n/a
2	Future Use	Up	n/a
3	Color Space HDMI Connector	Up = HDMI (YCbCr)	Down = DVI (sRGB)
4	Program/ Update	UP = No Program	DOWN = Ready To Program
5	Future Use	Up	n/a
All Down	Reset to Defaults	All UP	ALL DOWN (with power cycle)



3. **RS-232 IN:** Serial RS-232 input on a RJ-45 connector. This control port allows a Vaddio joystick controller or 3rd party controller (Crestron/AMX) to control the camera functions if the embedded webserver is not used for real time control.
4. **RS-232 OUT TO CAMERA:** Serial RS-232 output on RJ-45 connects via Cat-5e to the camera RS-232 input on the camera. Control signals from the embedded webserver are sent via RS-232, or RS-232 from external controllers is relayed to the camera over this control port.
5. **EZ POWER VIDEO:** RJ-45 jack used to supply 24 VDC power to the camera and return differential video from the camera on Cat-5e cable at a maximum distance of 100' (30.48m) with PTZ cameras and up to 150' (45.7m) with stationary POV cameras (i.e. ZoomSHOT and WideSHOT).
6. **YPbPr Output:** Analog component video output on a DE-15 (HD15) connector (resolution is set on the back of the camera). The YPbPr output resolution will be the same as the HDMI output resolution. SD video resolutions (Y/C and CVBS formats) are not supported by the Quick-Connect USB Interface; however some progressive frame analog component SD video is supported.
7. **HDMI Output:** The digital video output on the HDMI connector can either be YCbCr color space (normal HDMI mode) or can be changed to DVI-D color space (sRGB) for older monitors and devices. The HDMI and YPbPr outputs work simultaneously and are the same resolution (set at the camera).
8. **Ethernet 10/100 Network RJ-45 Jack:** The Ethernet jack will have yellow and green lights to indicate connectivity and activity of the network on that jack. The Ethernet jack will stream video (up to 1080p/30 H.264 and can be set from the internal web pages much like the HD-USB Camera. The resolutions will available in a three (3) stage quality format (High Quality, Good Quality and Standard Quality targets) and includes a range of CIF to 1080p/30.
9. **USB 2.0 Connector:** The USB 2.0 is on a Type-B female jack and connects to a PC running a soft-client video conferencing system or video capture software that uses UVC (USB Video Class) standard drivers. No other USB 2.0 drivers are required to plug the QC-USB into a computer and have it work. The UVC drivers will auto negotiate the top resolution that the PC and QC-USB can accomplish together and auto-implement.

BASIC APPLICATION DIAGRAM

Diagram: ClearVIEW HD-20se QUSB in UC Conferencing Application

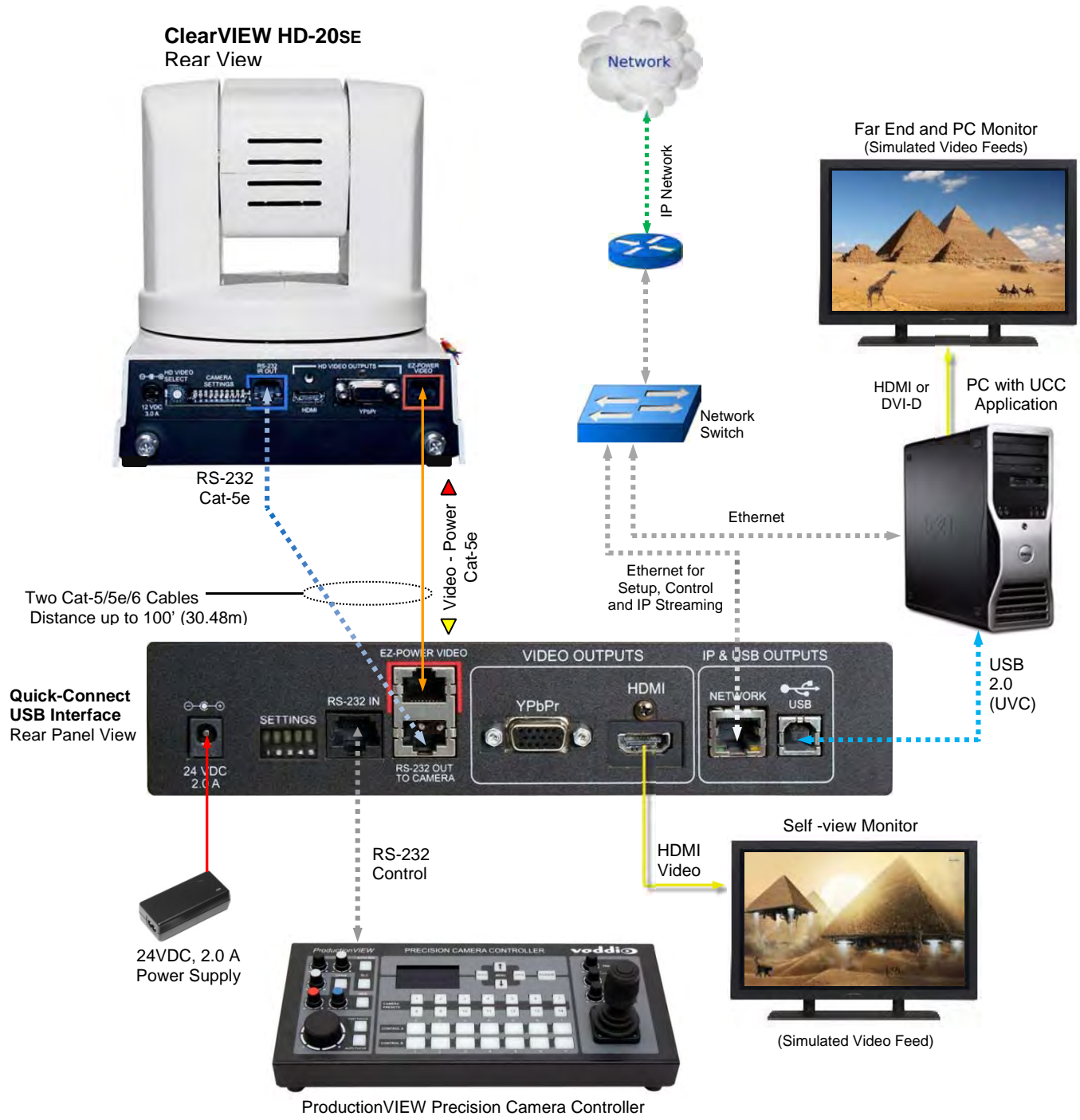

Note: RS-232 can be run directly to the camera or through the Quick-Connect USB as in this configuration

FIRST TIME SET-UP WITH THE CLEARVIEW HD-20SE QUSB SYSTEM

The ClearVIEW HD-20SE camera in the QUSB Kit was designed to be very easy to use and operate. There is documentation at the back of this manual for pin-outs of the connectors. Using the HD VIDEO SELECT rotary switch and CAMERA SETTINGS DIP switches on the back of the camera, set up the camera's output resolution and functional preferences. There is a label on the bottom of the camera that identifies the choices.



HUGE USB NOTE: For best results with USB 2.0 streaming, select video resolution position "0" (720p/59.94). MJPEG is limited to 720p, so starting higher only adds a layer of scaling. Position "0" also works well with IP streaming...so please try position "0" first for USB 2.0 UVC Streaming.

Image: ClearVIEW HD-20SE Rear Panel Connections

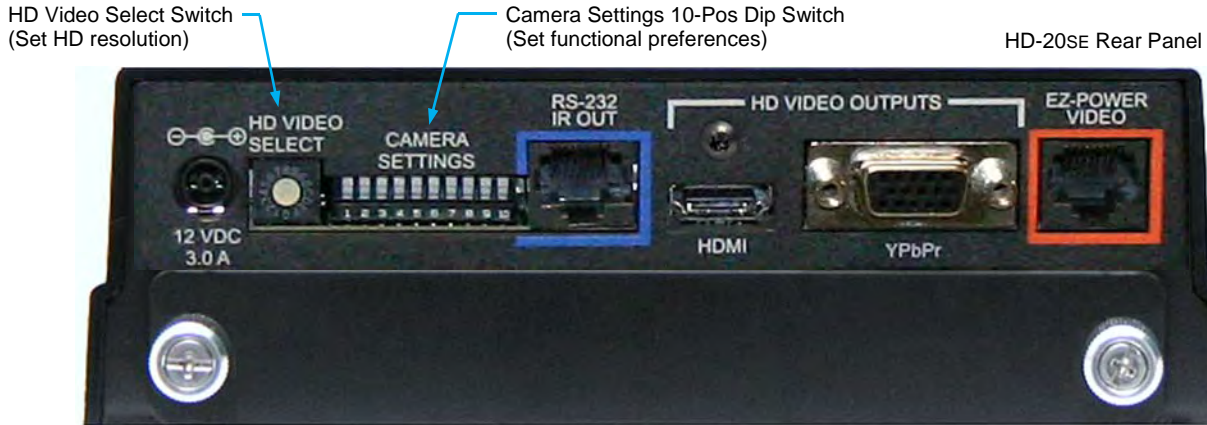

Drawing: Dip Switch and Resolution Label on the Bottom of the HD-20SE

② DIP SWITCH SETTINGS										① HD VIDEO SELECT			
IR 1 1 & 2 UP	IR OUT OFF	9600 bps	5 OFF	6 OFF	HDMI COLOR YCbCr	IMAGE FLIP OFF	9 OFF	10 OFF	0	720p/59.94	8	1080p/50	
<input checked="" type="checkbox"/>	<input checked="" type="checkbox"/>	<input checked="" type="checkbox"/>	<input checked="" type="checkbox"/>	<input checked="" type="checkbox"/>	<input checked="" type="checkbox"/>	<input checked="" type="checkbox"/>	<input checked="" type="checkbox"/>	<input checked="" type="checkbox"/>	1	1080i/59.94	9	---	
<input checked="" type="checkbox"/>	<input checked="" type="checkbox"/>	<input checked="" type="checkbox"/>	<input checked="" type="checkbox"/>	<input checked="" type="checkbox"/>	<input checked="" type="checkbox"/>	<input checked="" type="checkbox"/>	<input checked="" type="checkbox"/>	<input checked="" type="checkbox"/>	2	1080p/59.94	A	---	
<input checked="" type="checkbox"/>	<input checked="" type="checkbox"/>	<input checked="" type="checkbox"/>	<input checked="" type="checkbox"/>	<input checked="" type="checkbox"/>	<input checked="" type="checkbox"/>	<input checked="" type="checkbox"/>	<input checked="" type="checkbox"/>	<input checked="" type="checkbox"/>	3	720p/60	B	---	
<input checked="" type="checkbox"/>	<input checked="" type="checkbox"/>	<input checked="" type="checkbox"/>	<input checked="" type="checkbox"/>	<input checked="" type="checkbox"/>	<input checked="" type="checkbox"/>	<input checked="" type="checkbox"/>	<input checked="" type="checkbox"/>	<input checked="" type="checkbox"/>	4	1080i/60	C	---	
<input checked="" type="checkbox"/>	<input checked="" type="checkbox"/>	<input checked="" type="checkbox"/>	<input checked="" type="checkbox"/>	<input checked="" type="checkbox"/>	<input checked="" type="checkbox"/>	<input checked="" type="checkbox"/>	<input checked="" type="checkbox"/>	<input checked="" type="checkbox"/>	5	1080p/60	D	---	
IR 2 ON	IR 3 ON	ON	38400 bps	---	---	sRGB COLOR	ON	---	6	720p/50	E	1080p/30	
1	2	3	4	5	6	7	8	9	7	1080i/50	F	1080p/25	

⑦ All Down with Power Cycle for Defaults

Setting the Switches:

- Set the desired and available HD output resolution for the camera with the Rotary Switch.
- Set the IR control frequency of the camera if it is to respond to the IR remote control.
- If using the IR forwarding features with a 3rd party codec remote, set the IR OUT switch to ON (SW3).
- Set the Baud Rate dip switch (SW4) to 9600bps for most applications. Default is 9600 bps for Cat-5/5e/6 systems.
- To set the HDMI or DVI color space, use dip switch 7 (SW7).
- If inverting the camera, turn the IMAGE FLIP ON (SW8).
- All dip switches DOWN with a power cycle loads the default camera settings. Return dipo to desired operating position.

DIP Switch Settings Explained:

- IR 1, 2 and 3 (SW 1 & 2):** A single IR remote has the capability of operating up to three different PTZ cameras in a room. Use these selector dip switches and the selector buttons at the top of the IR remote to select the frequency.
- IR OUT on/off (SW3):** The IR output is sent out on the RS-232 RJ-45 jack on the back of the camera. Turning on the IR output will allow IR signals to be transmitted over the Cat-5e cable to the head end from 3rd party remotes. When using RS-232 control or Vaddio CCU controllers (also via RS-232), turn the IR OUT to OFF (up).
- Baud Rate (SW4):** The options for baud rate are either 9600 or 38,400 bps. The 9600 bps works best with Cat-5e.
- HDMI Color or sRGB Color space (SW7):** Default is YCbCr. Use sRGB color space with older DVI-D 1.0 equipment or monitors only. The YCbCr color space is used for HDMI digital video.
- Image Flip (SW8):** To invert the HD-20, turn the IMAGE FLIP ON (switch down).
- Dip Switches 5, 6, 9 and 10:** Not used for operation, please leave these dip switches up or in the OFF position.
- Restore to Factory Defaults:** All DIP switches down and a power cycle will restore the camera to factory defaults.

INSTALLATION PROCEDURES

Before Installing the Camera:

Choose the camera mounting location while paying close attention to camera viewing angles, lighting conditions, possible line of site obstructions, and checking for in-wall obstructions where the camera is to be mounted. Always pick a mounting location that will optimize the performance of the camera. Please locate the camera to enable easy positioning of the camera body with the ability to point down and away from the ceiling and a pile of fluorescent lighting cells. *Cameras generally don't like to be swamped with fluorescent light and nobody sits on the ceiling anyway.*



Installation Basics:

This camera system was specifically designed for installation on a vertical wall surface with Cat-5e cable connectivity for Video, Power and Control signaling (two Cat-5e cables are required with the QUSB system). This cabling ideology is especially convenient when the camera location is not anywhere near to an AC outlet. Installation is simplified in that no custom 8-Pin mini-din cables or expensive plenum coax cables or multi-pin cables are needed and no power outlets are required near the camera bracket. All Cat-5e cabling is routed to the head-end using with standard straight through RJ-45 connectors (568B termination). *"Pass-thru" type RJ-45 connectors should be avoided, like rocking-out on top of a ladder, which should be avoided too.*



General Installation Instructions for the CONCEAL Wall Mounting System:

Step 1: Determine Camera Mount Location

After determining the optimum location of the camera system, route both of the required Cat-5e cables from the camera to the head-end. Mark the cables EZ-POWER VIDEO and RS-232 accordingly.

Both Cat-5e cables should feed-through a 1" (25.4mm) opening (circular or square shape) centered in the rectangular slot located on the rear flange of the CONCEAL Wall Mount Bracket.



Note: Do not cut out the entire rectangular slot opening in the wall! This will not allow the two lower wall anchors to correctly fasten the CONCEAL bracket to the wall.

If the bracket is to be mounted on a 2-gang wall box, use the screws supplied with the wall box cover plate to attach the CONCEAL Wall Mount Bracket. If mounting to drywall with wall anchors, use the four (4) quality wall anchors/screws provided.

Note: The mounting holes are slotted and are 90° opposing to provide easy leveling. Level the mount and tighten the mounting screws. The example of the CONCEAL mount shows an HD-USB, but the steps are identical for the HD-20SE.



CONCEAL Wall Mount Bracket:
Cabled and Attached to Wall



Camera aligned and attached to the CONCEAL Wall Mount Bracket (by two-(1/4"-20) screws in the bottom of the mount).



Note: Check all Cat-5e cables for continuity in advance of final connection. Plugging the POWER/VIDEO Cat-5e cable into the wrong RJ-45 may cause damage to the camera system and void the warranty!

Step 2: System Wiring

Follow the sample wiring diagrams for connecting the Cat-5e cables to the camera and Quick-Connect DVI/HDMI-SR Interface. Additional diagrams are available on the Vaddio website.

Connect the camera side as follows:

1. Connect the EZ-POWER VIDEO Cat-5e to the EZ POWER VIDEO RJ-45 jack on the back of the camera.
1. Connect the RS-232 Control Cat-5e to the RS-232 IR OUT RJ-45 on the camera.

Connect the Quick-Connect USB side as follows:

With the Quick Connect USB not powered-up

1. Connect the EZ-POWER VIDEO Cat-5e from the camera to the EZ-POWER VIDEO RJ-45 jack.
2. Connect the RS-232 Cat-5e cable to the RS-232 OUT TO CAMERA RJ-45 jack.
3. Connect the controller to the RS-232 INPUT. The controller can be routed directly to the camera if preferred.
4. Connect the desired video outputs to the video destination inputs.



Note: Please check all Cat-5e cables for continuity in advance of final connection. Plugging the EZ-POWER VIDEO Cat-5e cable into the wrong RJ-45 may cause damage to the camera system and void the warranty!

Step 3: Secure the Camera To the CONCEAL Wall Mount Bracket

After all cables are attached to the camera, slide the camera back onto mount and insert the two 1/4"-20 screws into the camera through the two-screw slots in the bottom of the mount. **Note:** Be sure to align each side of the camera evenly for the best fit prior to tightening down the mounting screws.

Step 4: Install the CONCEAL Lower Cover Plate

Attach the CONCEAL lower cover plate. Slide the lower cover plate from front of the mounting bracket toward the rear of the bracket. The two (2) rear locking tabs will need to be guided into position first and will lock in place as the lower cover plate is pushed toward the rear of the mounting bracket. The two (2) front tabs will engage as the cover is pushed back into place.

CONCEAL Lower Cover Plate with Locking Tabs



CONCEAL Lower Cover Plate locked in place



Step 5: Install the CONCEAL Rear Camera Cover

Install the CONCEAL rear camera cover on the mounting bracket with the supplied screw.

CONCEAL Rear Camera Cover



Completed CONCEAL Wall Mount Camera Bracket Installation



QUICK-CONNECT USB INSTALLATION INSTRUCTIONS

Follow the sample wiring diagram for connecting the Cat-5e cables to the cameras and Quick-Connect USB Interface (Diagram on page 9, but read and understand the rest of these instructions especially the next note).



NOTE: Check all Cat-5 cables for continuity in advance of the final connection. Label the Cat-5 cables. Please do not use the “trial and error” method of connectivity. Know what cable goes where prior to termination.

Connecting System Power

Connect the DC side of the 24 VDC power supply to the Quick-Connect USB Interface and the AC plug into an AC outlet. The Quick-Connect USB will initialize, Power will travel down the EZ-POWER VIDEO Cat. 5 cable to the camera. The camera will boot up and in a few seconds, differential HD video will travel back down the Cat-5 cable to the Quick-Connect USB. When an image is available, the camera is ready to accept control information from the IR remote control or RS-232 camera controller, however it is always best to choose and use IR or RS-232 and not both concurrently. If connected to the Network, the Quick-Connect USB will display the Hardware (HW) MAC Address and the IP address on the front display.

Controlling the Quick-Connect USB

RS-232 Control: An API is provided for control of the cameras over RS-232 through the Quick-Connect USB. The camera RS-232 commands are in the back of this manual).

Telnet Control

The cameras can be controlled through the Quick-Connect USB via Telnet session. These exciting commands are listed at the back of the manual.

Built-in Webserver Control

The Quick-Connect USB has a built-in webserver that auto-loads the control protocols of the Vaddio camera attached (pretty cool huh?). Full camera controls including CCU image controls are available from any approved browser on any computer. The IP address is always displayed on the front panel display of the Quick-Connect so access to the internal webpages is super accessible and easy. The Screen Shot Tour will provide guidance for operation, but jumping in and looking at the web server pages directly is a better way to learn the operation of the system.

Quick-Connect USB Details

The Quick-Connect USB Interface uses UVC (Universal Video Class) drivers for USB 2.0 video and does not require the loading of any other drivers to run on the PC. As long as the operating systems and soft-client software support UVC drivers, no additional software/drivers, other than the application is required.

Boot Order Notes

When using a joystick controller or external control system, in order to ensure proper continuity of camera control, the RS-232 controller should be powered-on after the camera and Quick-Connect. In most, if not all cases, the camera needs to be on and running in order for communication to take place between the camera and controller. When plugging a new camera into a RS-232 controller/joystick that has already been powered up, a system reboot or camera rescan may be necessary to find the camera

CONTROLLING THE CAMERA

IR Remote Commander

The following functions are accessible with the Vaddio IR remote:

- Camera Power On/Off (Toggle on/off same button)
- Back Light Compensation (Toggle on/off same button)
- Data Screen: Used to access OSD camera functions
- Camera Select (the remote can operate 3 cameras (with 3-IR Freq.))
- Pan/Tilt and Home controls with Reverse and Std. Pan direction
- Pan/Tilt Reset
- Auto Focus (Toggle on/off same button)
- Zoom In/Out controls Wide & Telephoto
 - Fast speed controls (W & T)
 - Slow speed controls (W & T)
- Manual Focus On/Off control (Toggle on/off same button)
 - Near (-) adjustment
 - Far (+) adjustment
- Six (6) pan/tilt/zoom positioning presets (1 through 6)
- Preset Set (store)
- Preset Reset (clear)
- Red LED that indicates IR Transmission and battery level

Vaddio
IR Remote
Commander



The IR Remote operational characteristics are as follows:

- **Preset Activation:** IR Remote is limited to executing Presets 1 through 6.
- **Preset Store:** IR Remote is limited to positional (PTZ) type presets. To set a preset, position the camera, hold down the Preset Button and touch the one of the preset numbered buttons 1 through 6.

Telnet Control of the Camera through the Quick-Connect USB

The following *Telnet commands are available through the Ethernet Port.

- Camera Home
- Camera Pan (left, right and speed - real-time operation)
- Camera Tilt (up, down and speed - real-time operation)
- Camera Zoom (zoom in/out/stop and speed - real-time operation)
- Camera Store Preset (Gets or Sets 12 presets with global relative PTZ speed control)
- Camera Image (Gets or sets current image control values, sets in 1 of 3 CCU presets) (AWB or manual w/Red and Blue gain, BLC on/off, Auto Iris or manual with Iris value and Gain, Detail and Chroma)
- Camera Sleep (Gets or sets standby power mode - camera has to us less power in this mode)
- Exit (ends Telnet session)
- Help (displays CLISH syntax)
- History (command history)
- Network Ping (send ICMP ECHO_REQUEST to network hosts)
- Network Settings (Gets MAC address, IP address, Subnet Mask, Gateway and NTP server address)
- Network (Gets the current network settings or pings an IP address)
- Streaming Mode - *USB or IP needs to be changed to USB and IP* (get and set streaming modes, on/off)
- Streaming Quality (gets/sets high/standard/low for IP)
- Streaming Resolution (gets/sets streaming resolution)
- Streaming (gets/sets current streaming settings)
- System Factory Reset
- System Reboot
- Version (system version information)

*Please see the full Telnet command list at the end of this manual



QUICK-CONNECT USB SOFTWARE COMPATIBILITY

The Quick-Connect USB will work with the following web browsers, soft codecs, computer operating systems and media players:

Compatibility - Web Browsers:

- 1) Internet Explorer (IE 8 and above)
- 2) Safari (Rev 4 and 5)
- 3) Safari/iOS (Rev 4 and 5)
- 4) Chrome (the latest and current release - auto updating)
- 5) Firefox (the latest and current release - auto updating)

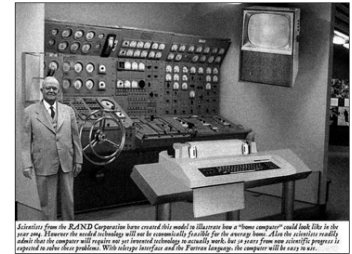

Soft Client Compatibility: The Quick-Connect USB is compatible with the following soft codecs or applications, in no particular order:

- | | |
|--------------------------------|-------------------------|
| 1) Skype | Win 7 & Mac OS X (10.7) |
| 2) Web Ex (WBS 28.7 and up) | Win 7 & Mac OS X |
| 3) Microsoft Lync | Win7 |
| 4) Cisco Jabber | Win 7 & Mac OS X |
| 5) Vidyo Desktop | Win 7 & Mac OS X |
| 6) Google Plus | Win 7 |
| 7) Adobe Connect 8 | Win 7 & Mac OS X |
| 8) LifeSize ClearSea | Win 7 |
| 9) GoToMeeting (Citrix) | Win 7 & Mac OS X |
| 10) Polycom M100 | Win7 |
| 11) Panaopto (lecture capture) | Win 7 |

Compatibility: Media Players:

The UVC with MJPEG and IP with H.264 video are compatible with the industry leading PC media players.

- Quick-Time 10.2
- VLC Media Player 2.0.4
- Real Player 16.0

Compatibility: Operating Systems

- Apple OS X (10.7 and above)
- Windows XP w/Service Pack 3 with known issues and errata
- Windows 7
- Linux

Evolving Compatibilities:

As more UC soft-client and lecture capture programs are released and gain popularity, Vaddio will provide a continuing research and development effort to ensure the compatibility with other manufacturer’s products.

USB 2.0 UVC Drivers

The USB 2.0 UVC (Universal Video Class) video driver resolution table is an internal list of resolutions available for the Host PC and the Quick-Connect USB to negotiate and use for any approved/tested USB application. Typically, the highest resolution possible between both the PC and Quick-Connect USB is used. However, not all OS and application combinations are altogether typical.

Table: Supported UVC Resolutions

Format	Resolution	Frame Rates	Aspect Ratio
MJPEG	1280 x 720 (720p)	15/30	16:9
	960 x 544	15/30	16:9
	704 x 576	15/30	4:3
	640 x 480	15/30	4:3
	640 x 360 (360p)	15/30	16:9
	424 x 240	15/30	4:3
	352 x 240	15/30	4:3
	320 x 240	15/30	4:3
	320 x 180 (180p)	15/30	16:9

QUICK-CONNECT USB INTERNAL WEB PAGES AND CONTROL

The internal web pages will allow control of the Quick-Connect USB and control of the attached camera via a network connection. These web pages will allow the user or administrator to set security passwords, change the IP address, view diagnostics, access the firmware upgrade page and more!

DHCP IP Set-up (Dynamic Host Configuration Protocol)

DHCP Set-up (skip this section if Static IP). If the LAN has a DHCP (dynamic host configuration protocol) server, then the IP address, gateway and routing information will automatically be assigned. The QC-USB software is defaulted to DHCP and will attempt to dynamically obtain an IP address using DHCP, but it will fall back to the default address of (169.254.1.1) if no DHCP server can be found.

Static IP Set-up:

The static IP can be assigned either through the network or directly to a computer using a cross-over cable. Depending on the age of the computer, you may not need a cross-over cable. Either way the steps are the same for network or direct connection to a computer. The default address of the QC-USB camera is 169.254.1.1 and the Subnet mask is 255.255.0.0. Different computer OS types all have their own way of doing things (without question), but they are essentially doing the same stuff, changing the IP address so the web pages of the HD-USB are accessible.

Quick-Connect USB Web Pages Tour:

Screen Shot: Login

The webserver is intended as a user's camera control page at one level, and an administrator's management tool at another level, which requires password authentication for full access.

The Login Page will appear if there is a user name assigned by the administrator. Assigning a user name can limit access to the admin menus by a general user.

By default, the User name is: [user](#), and the password for the User account is: [password](#).

The Administrator can set the name and password for the User account.

By default, the Admin user name is: [admin](#), and the password for the admin account is: [password](#)

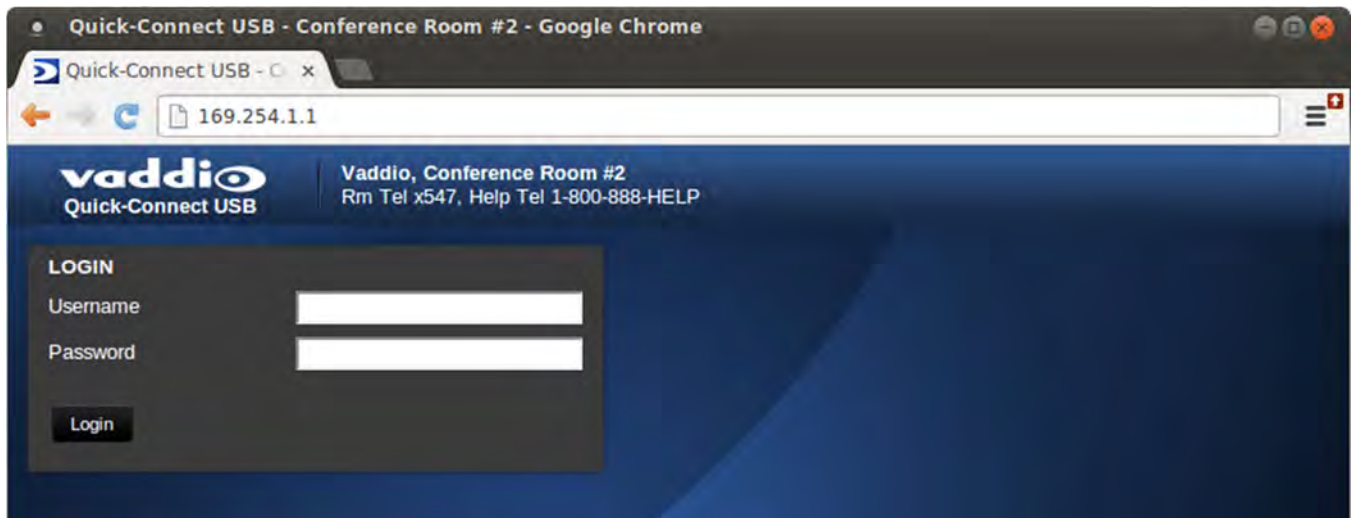

If a user or an admin logs in through this screen, then the next page shown will be the camera control page.

The user will only have access to the camera control page.

The Admin will have complete access to all web pages.

Screen Shot: User Menu - Camera Control Page

This web page provides access to the camera controls for the User and the Admin.

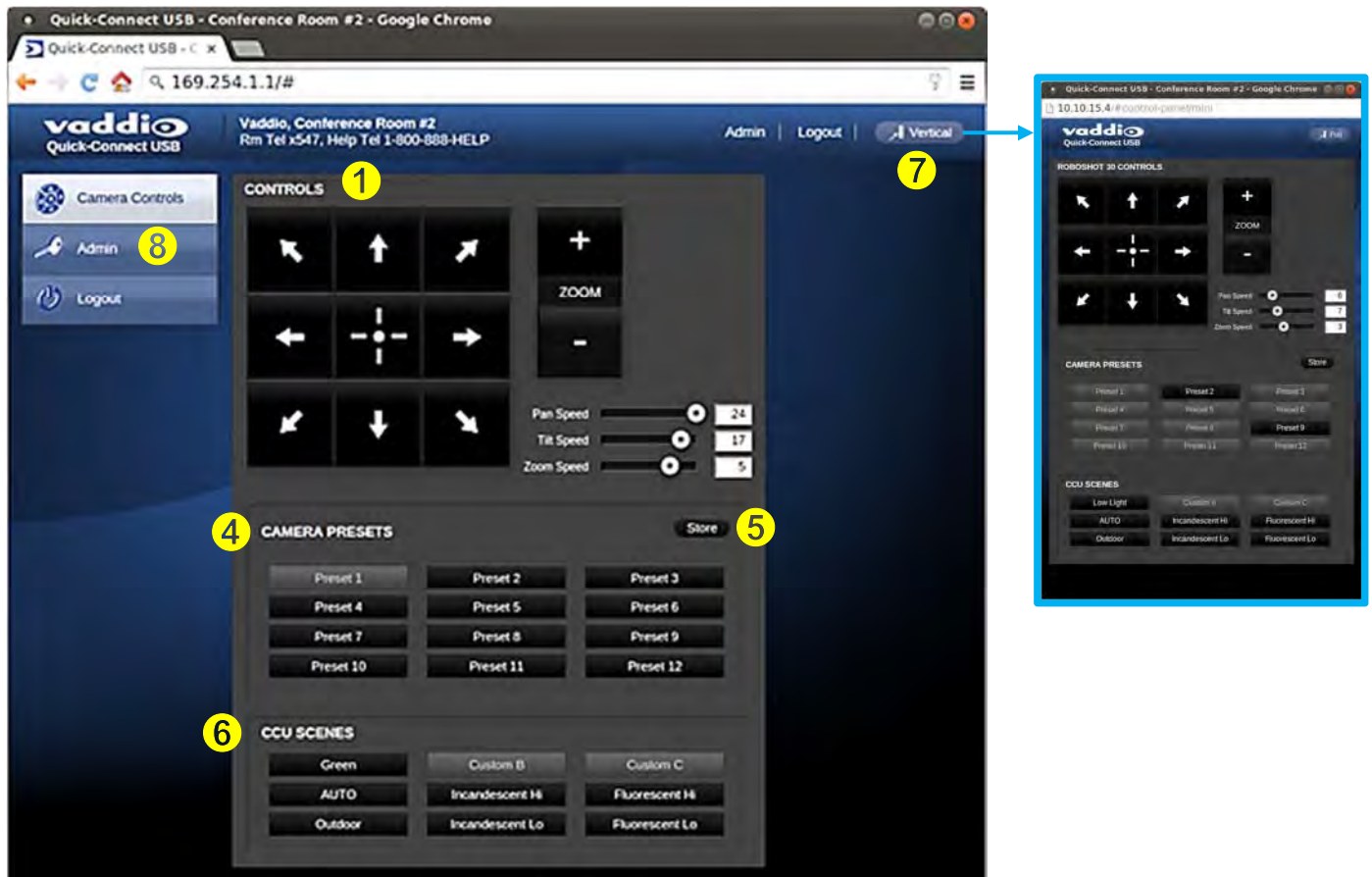

- 1) **Pan, Tilt and Home Controls:** These intuitive controls use the up/down and diagonal arrows for camera pan and tilt. The center button will move the camera to the home position.
- 2) **Zoom Control:** The camera's zoom lens can be controlled with the "+" to zoom-in and the "-" to zoom out.
- 3) **Pan/Tilt and Zoom Speed Controls:** The speed for both the Pan/Tilt and Zoom controls can be adjusted with the three (3) sliders in this section. For tighter shots, it is recommended that the slower speed is used. These controls are for real-time camera movements only.
- 4) **Camera Presets:** Twelve (12) camera position presets can be recalled simply by clicking a preset number.
- 5) **Store Preset Button:** Clicking the Store button opens up a Store Preset pop-up dialog box. To set presets, set up the camera shot, click on choice of preset number (1 through 12). The preset is stored and the dialog box closes.
- 6) **CCU Scenes:** The user has access to the CCU scenes set and stored on the Admin pages. There are three (3) user definable presets and six (6) presets preconfigured by the technical folks at Vaddio (really Scott set them all) that are meant to be used in certain lighting scenarios. These lighting presets included: Automatic, Incandescent Hi, Incandescent Lo, Fluorescent Hi, Fluorescent Lo and Outdoor.
- 7) **Vertical Menu:** The vertical menu is smaller with only the camera controls allowing for the PC to use the camera controls during a UC conference. Click on the Full button to return to full screen.
- 8) **Administration Menu:** By clicking on the Administration menu bar, the Admin Login screen will appear.

Screen Shot: Admin login from the Camera Control Page

On the security page, which will be reviewed at a bit later in the tour, allows the Admin to set the system to allow automatic guest access to the main camera control page. If guest access is turned on by the Admin, then system will open to the camera control page and an additional Admin Login is provided.

The default Admin password is: *password*.

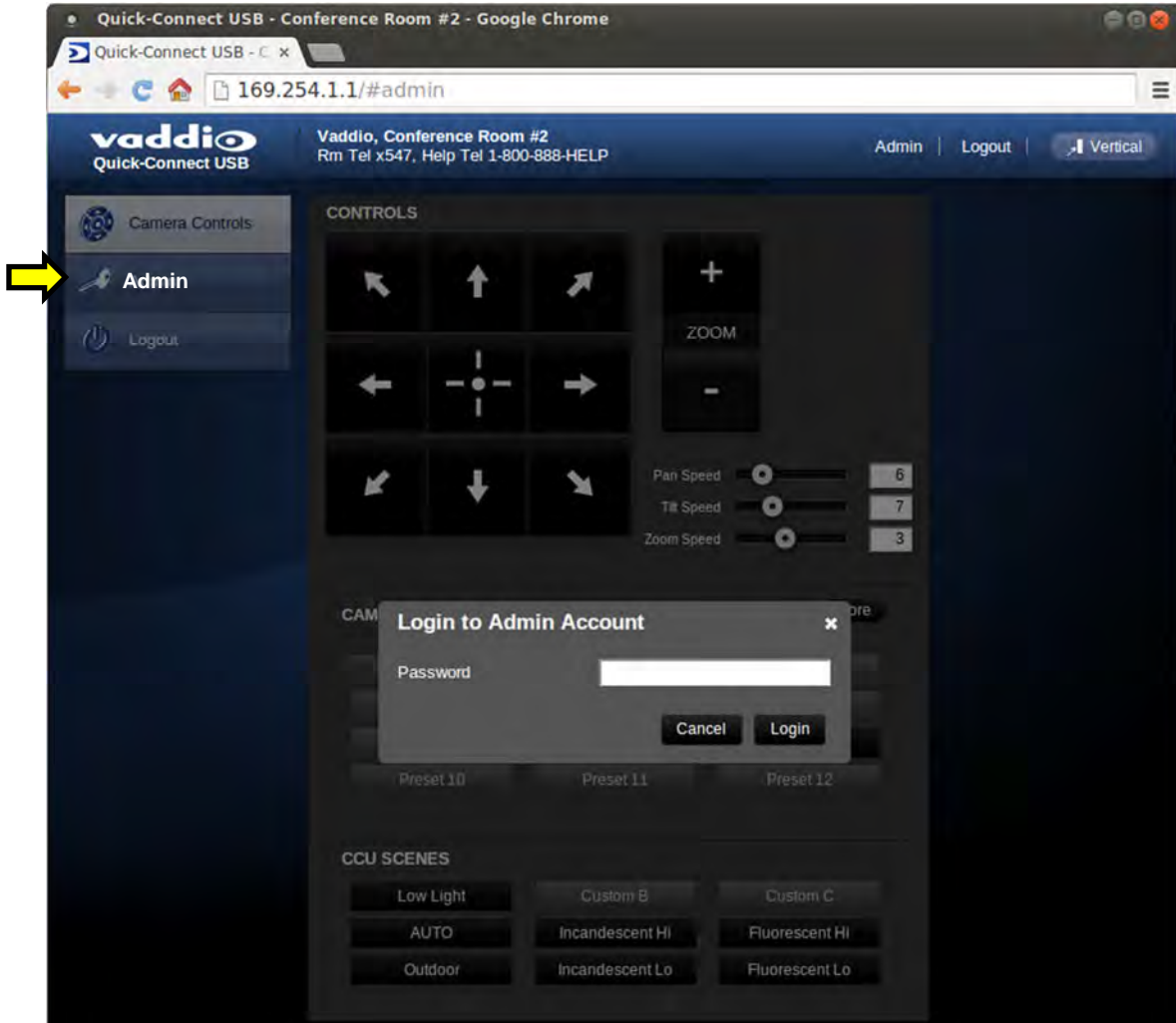

205 Westwood Ave, Long Branch, NJ 07740
Phone: 866-94 BOARDS (26273) / (732)-222-1511
Fax: (732)-222-7088 | E-mail: sales@touchboards.com

Screen Shot: Admin Menu - Camera Settings

Once the Admin logs in, then all the admin menu buttons appear on the left side of the screen. The first menu after camera controls is Camera Settings.

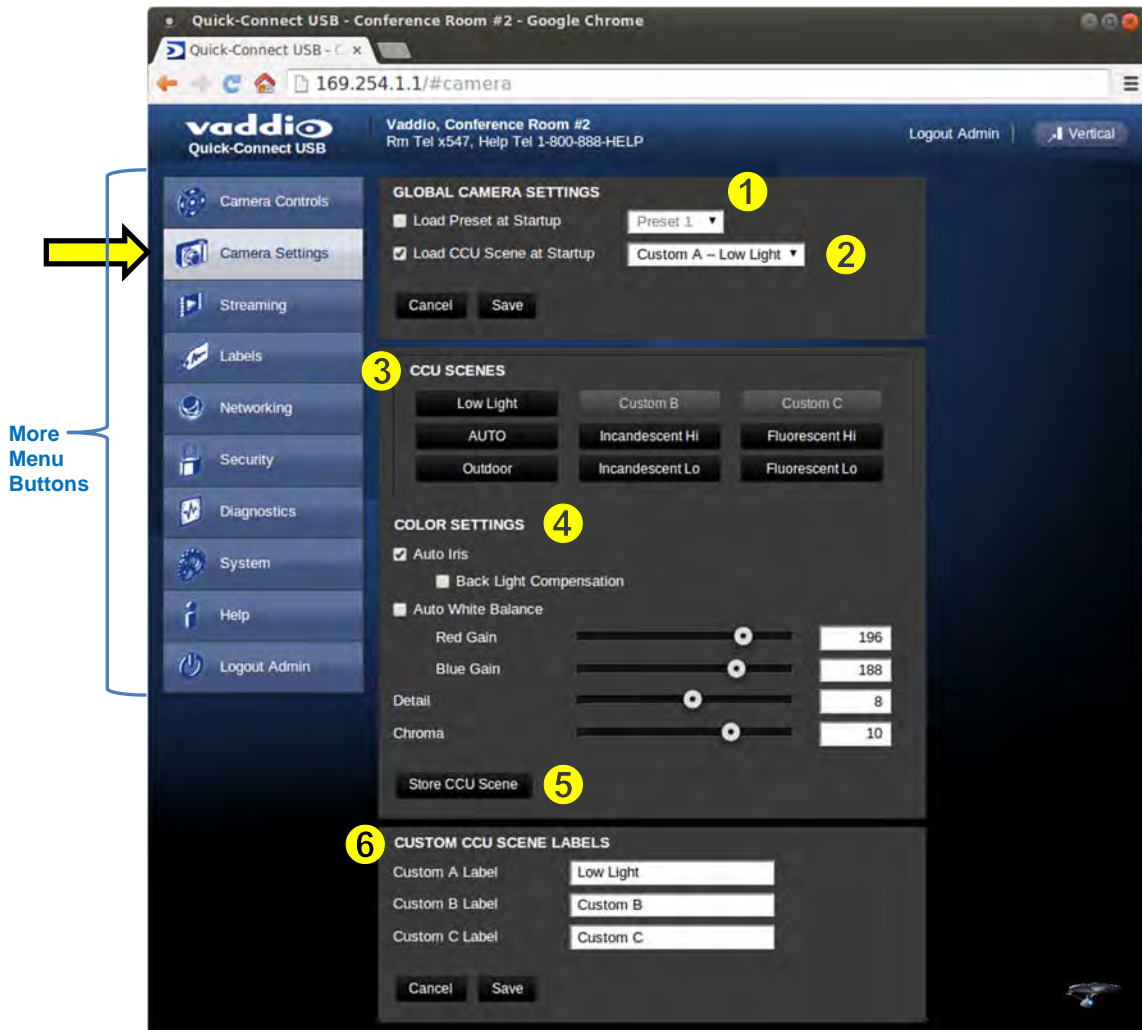

- 1) **Load Preset at Startup:** Check this box to move the camera to a predefined preset location when the camera powers up. Use the pull down menu to select the Preset 1 through 12 to be loaded when this box is checked.
- 2) **Load CCU Scene at Startup:** Check this box to load a CCU Scene into the camera when the camera powers up. The pull down menu will allow the selection of one of the 6-factory scenes, or one of the 3 custom scenes.
- 3) **CCU Scenes:** Click on any of these 9 buttons to load one of the CCU scenes into the camera. These Scenes can be fine-tuned if changes are needed, and stored into any of the three User defined scenes.
- 4) **Color Settings:** When painting or shading camera scenes for specific lighting situations or environments, these parameters can be adjusted for matching cameras in the same area. The parameters within the Color Settings section are defined below (top to bottom):

Auto Iris Check Box: When checked, the camera will operate in Auto Iris mode, when unchecked, the camera will be in Manual Iris mode and allow adjustment of Iris and Iris Gain levels.

- **Iris:** Move adjustment slider as required to adjust the iris opening. A numeric value will be displayed in the box to the right of the slider.
- **Gain:** Move slider as required for amount of iris gain desired. Numeric value will be displayed in the box to the right of the slider.

Auto White Balance check box: When checked, camera will operate in Auto White Balance mode, when unchecked camera will be in Manual White Balance Mode and allow for adjustment of Red and Blue Gain.

- **Red Gain:** Move the adjustment slider as required for amount of Red Gain desired. A numeric value will be displayed in the box to the right of the slider.
- **Blue Gain:** Move the adjustment slider as required for amount of Blue Gain desired. Numeric value will be displayed in the box to the right of the slider.
- **Back Light Compensation:** When checked, Back Light Compensation will be applied to the camera if camera is in Auto White Balance mode.
- **Detail:** Move the adjustment slider as required for amount of detail (Aperture) desired. A numeric value will be displayed in the box to the right of the slider. **Note:** If the detail is too high, the video can look grainy and appear ratty (technical term) too.
- **Chroma:** Move the adjustment slider as required for the amount of Chroma (Color Vibrancy) desired. A numeric value will be displayed in the box to the right of the slider.

5) **Store CCU Scene button:** Once the desired scene adjustments have been made, this button will activate a pop-up menu that can be used to store this scene into one of the three User Defined Scene locations. These User Defined Scenes can be named as required for clarity. These User Defined CCU Scenes can be adjusted and re-saved at any time.

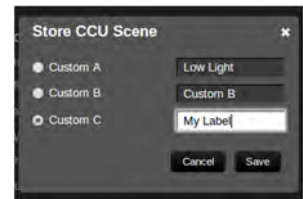

6) **Custom CCU Scene Labels:** The labels for the (3) User defined customizable scenes can be changed as needed. Move the cursor into the appropriate window and edit the text. Press Save to store these changes or press Cancel to exit this window.

Screen Shot: Admin Menu - Room Labels

The Room Labels menu allows the Admin to label the company name, room name, room phone and help phone on a per camera basis. The labels appear on every page at the top/middle of the page. Simply enter the room information and click Save.



Screen Shot: Admin Menu - USB 2.0 or IP Streaming Mode Page

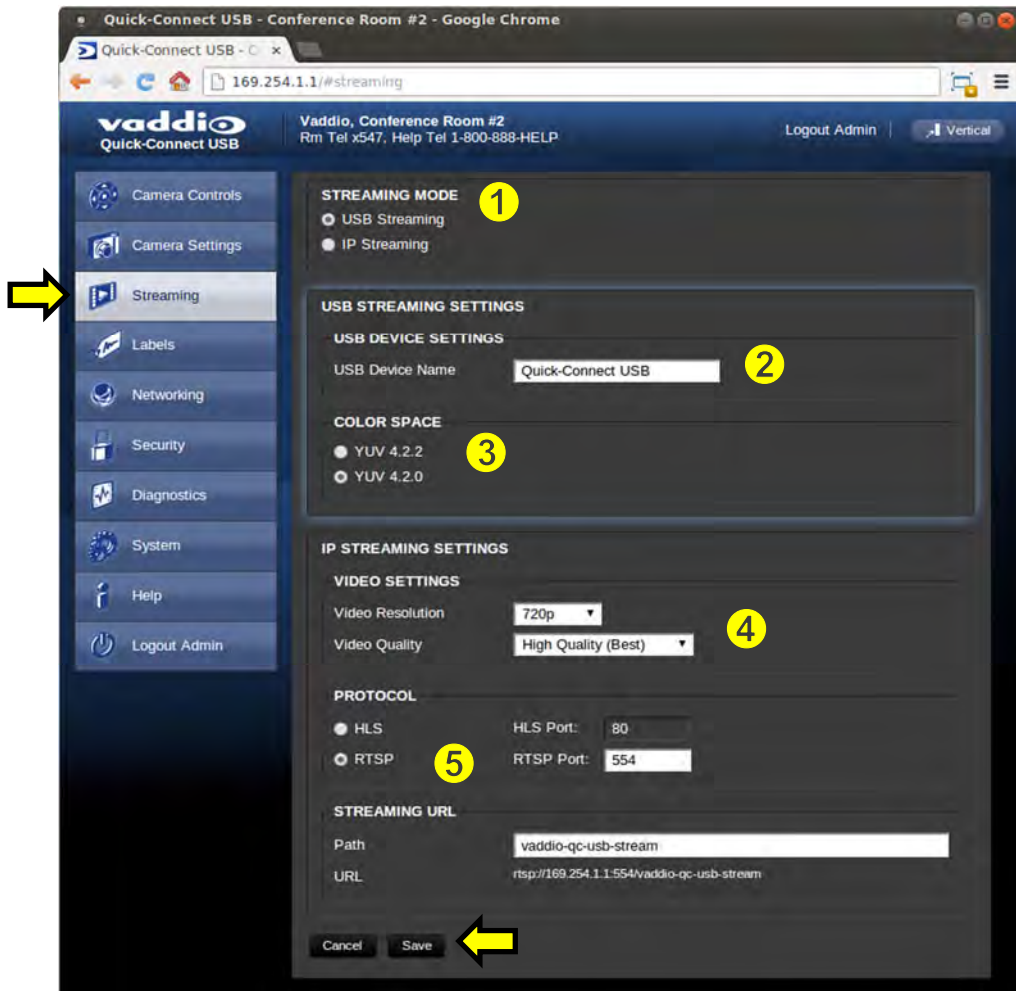

- 1) **Streaming Mode:** Streaming can be set for either USB 2.0 streaming (MJPEG) or IP streaming (H.264); but not both at the same time. The QC-USB can stream USB and accept IP control, or it can IP stream with IP control. Choose between USB 2.0 and IP streaming mode here.
 - 2) **USB Device Name:** Allows the user to use a “friendly name” per system. In a BYOD format, the user has the ability to move between different UC conference rooms and have the ability to assign the PC’s USB resources to that room.
 - 3) **Color Space:** The UVC drivers will negotiate the color depth, but this parameter allows the user to reduce the color depth to 4:2:0, which is used with the older/cheaper webcams and applications, where image quality is not as critical. The 4:2:2 color is used by many applications that take advantage of the performance of the camera where the colors are more vibrant and precise.
 - 4) **IP Streaming Settings:** The Video Settings allow the selection of the target performance for the IP Streaming. The QC-USB is set up for a variable bit rate and the user can select the video resolution and the quality, such as High Quality (Best), Standard Quality (Better) and Low Bandwidth (Good). Every effort to eliminate stupefyingly bad combinations with the 5 or 6 parameters that make up the image size, quality, bit rate, bandwidth etc... has been made, so you can’t pick 1080p at a bit rate of 128Kbps, which would look totally wicked awful - and probably wouldn’t work anyway.
 - 5) **Streaming Protocol and URL:** Admin chooses the streaming type and the port number for RTSP. The HLS port is always on 80. The supported protocols are RTSP and HLS (Apple’s HTTP Live Streaming). RTSP is best for live applications, where HLS serves the Apple iOS devices and is better for playback due to the amount of buffering the HLS has built-in. The Streaming URL auto populates and that path can be changed.
- When finished setting up the streaming parameters click Save to put the changes into effect or cancel, which will not save the configuration.

Screen Shot: Admin Menu - DHCP Network Configuration

Under the Networking menu, The Network Configuration and Network Interfaces are displayed. This is where the Network administrator assigns either DHCP or a Static address and the associated parameters.



Screen Shot: Admin Menu - Static IP Configuration

If Static IP is used, the IP Address, Subnet Mask and Gateway are manually entered. Click on Save to keep the Static IP information. Click Save after loading in the Static IP information



Screen Shot: Admin Menu - Security

The Security menu allows the Admin to **UPDATE “user” PASSWORD** and **UPDATE “admin” PASSWORD**. The default “user” password is: **password**. The default “admin” password is also: **password**. The Network administrator can reassign the user name and password as well as the Admin password. There is only one “user” password and one “admin” password at any given time. If changes are made, click on Save to store the change.



Screen Shot: Admin Menu - Diagnostics

Diagnostics menu button will display a set of self-diagnostics. These diagnostics may help the Vaddio technical support team diagnose a problem with the Quick-Connect USB and attached camera. The log can be downloaded and refreshed at the bottom of the screen.

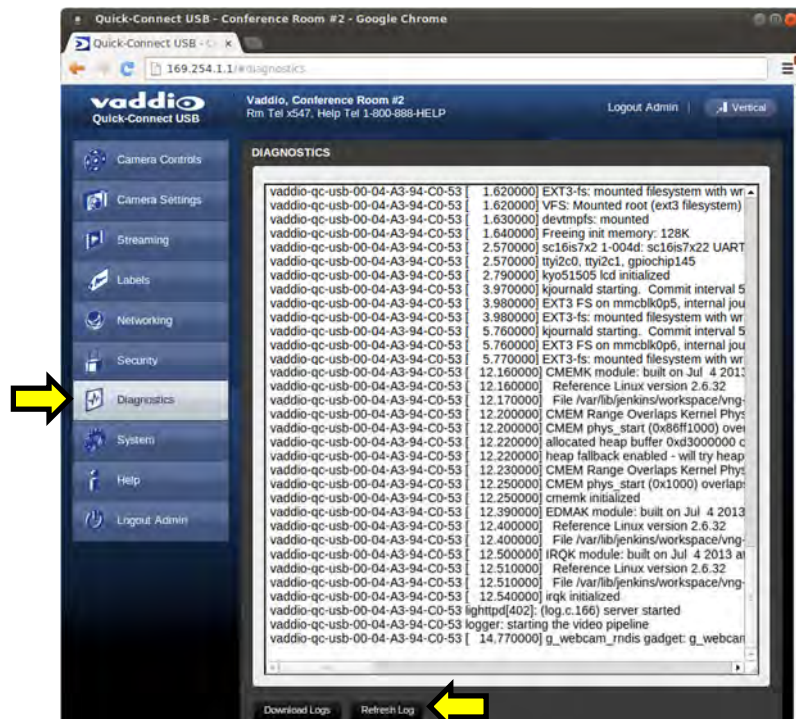

Screen Shot: Admin Menu - System Menu

The System Menu is where the System Info is displayed and Firmware Updates are performed. There will be firmware updates and upgrades over the life of the Quick-Connect. The file for the firmware update is chosen in this menu and the update is started here too. A remote system Reboot and Restore to Factory Presets is also available.

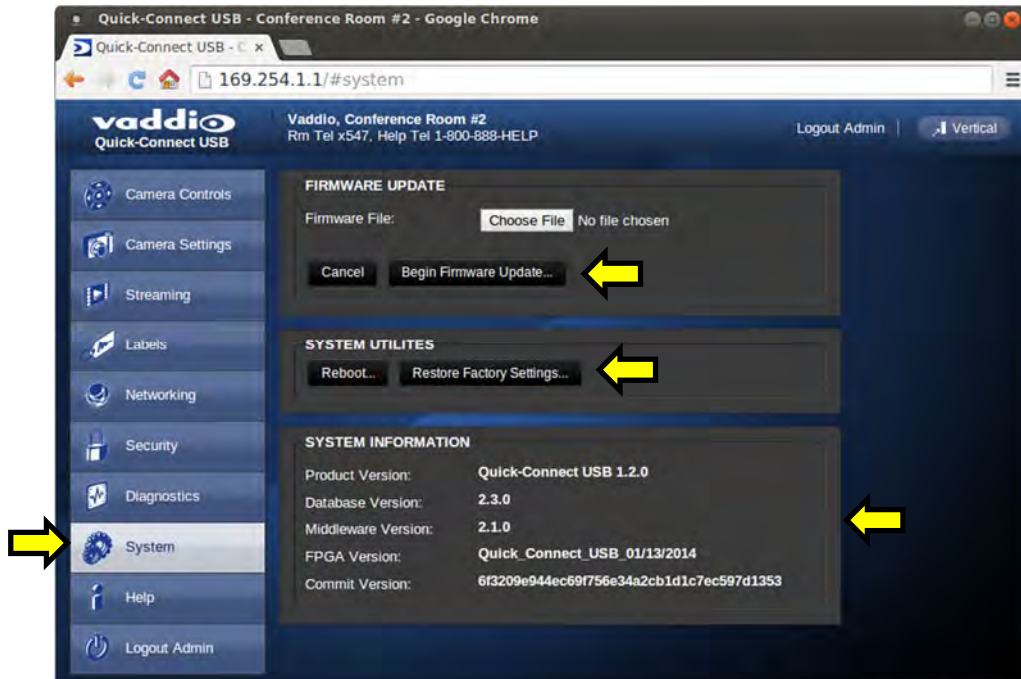

Screen Shot: Admin Menu - Update Confirmation

After choosing an update file and clicking on "Begin Firmware Update..." a confirmation pop-up and warning will be displayed. Please contact Vaddio Tech support for assistance with updates. Please read and completely understand the pop-up warnings as it is easy to lose patience waiting for updates. Click on continue to start the update

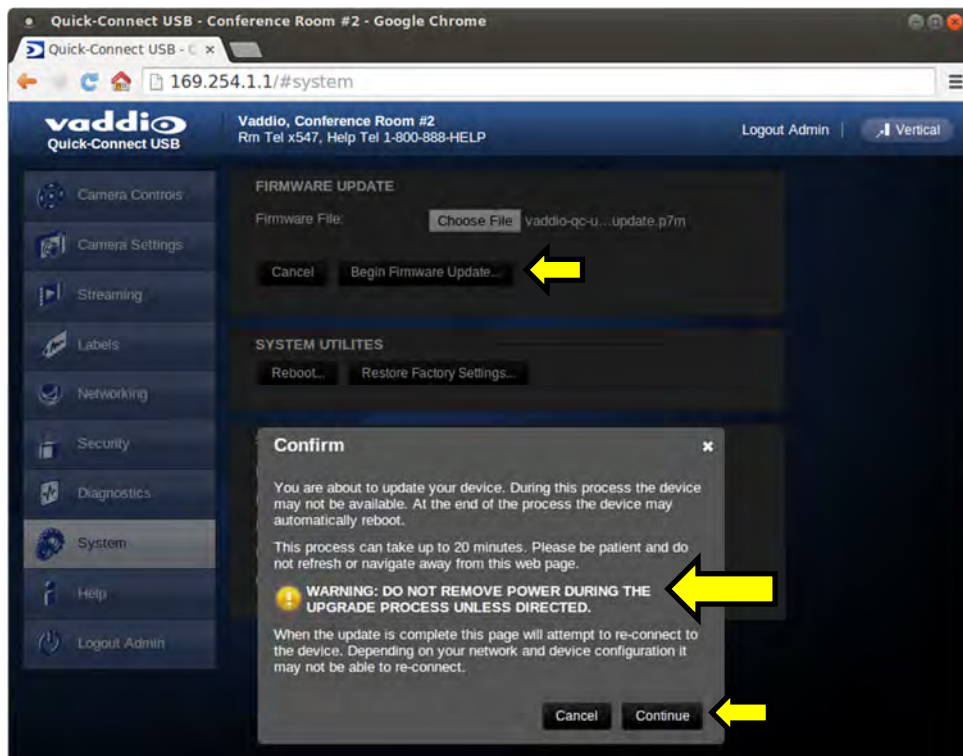

Screen Shot: Admin Menu - Update in Progress

After the firmware load has been started, a pop-up screen will advise patience and notify, in terms of percentage completed, the progress of the firmware update load. Again, please don't interrupt the firmware load

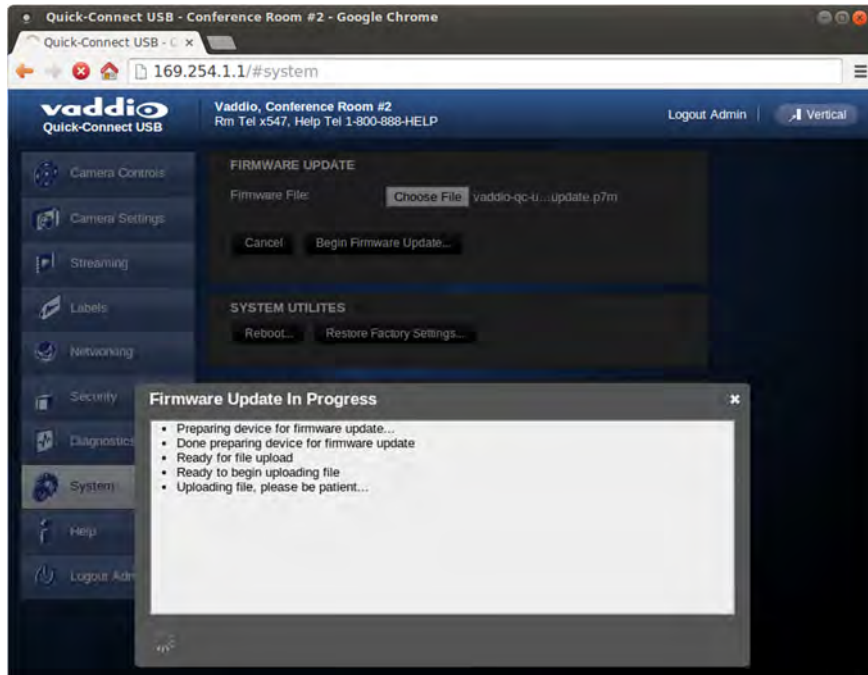

Screen Shot: Admin Menu - HELP

Service/Help information can be found under the Help menu. Support phone numbers and e-mail, manuals, FAQ's and System information is listed on this page. Have the System page open when calling Vaddio Tech Support.

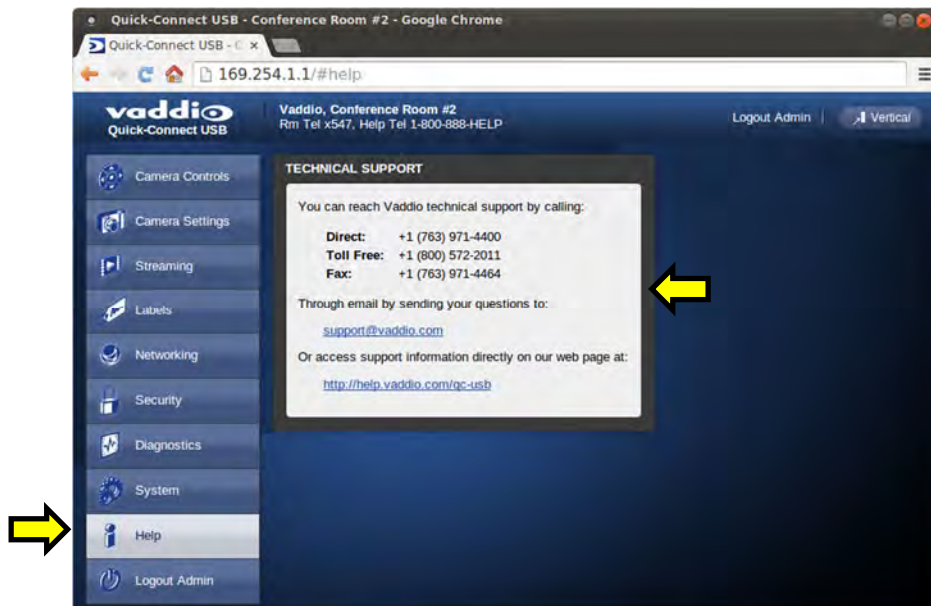

This concludes the Screen Shot Tour for the Quick-Connect USB, which was breathtaking, stimulating and provocative as one would expect. The General Specifications, Communication Specifications, API, Declarations of Compliance, Warranty Information and Telnet Command List are the next stop.

GENERAL SPECIFICATIONS:

ClearVIEW HD-20se, HD PTZ Camera	
Part Numbers	999-6986-000 (North America), 999-6986-001 (Int'l) - Black Camera Version 999-6986-000AW (North America), 999-6986-001AW (Int'l) - Artic White Camera Version
Image Sensor	1/2.8-Type Exmor, high-speed, low-noise CMOS Image Sensor 2.38 Megapixels (~2.07M effective pixels).
Zoom	20X Optical Zoom with Multi-element Glass Lens
Field of View	Horizontal: 63° Wide End to 3.47° Tele End, (16:9 Aspect Ratio) Vertical: 36.8° Wide End to 1.85° Tele End
Lens Focal Length	f=4.44mm to 89mm / F1.6 - F3.4
Minimum Illumination	Color: 0.3 Lux (F1.6, 1/30 sec, 50 IRE), B/W: 0.03 Lux (F1.6, 1/30 sec, 50 IRE)
Video Resolutions	HD: 1080p/60/59.94/50./30/25, 1080i60/59.94/50 and 720p/60/59.94/50 HD Video Resolutions Only at 16:9
White Balance	Auto, Manual (Red and Blue Gain), OPWB, Indoor, Outdoor and Fluorescent
Video Output Formats	HDMI, Analog Component, HSDB (Differential Video, Power and Control for Quick-Connects)
Signal to Noise Ratio	Greater than 50 dB (AGC: Off)
Compatible Quick-Connects	Quick-Connect SR, Quick-Connect DVI/HDMI SR, Quick-Connect USB and Quick-Connect Universal CCU
Pan Range	Pan: +170 degrees to -170 degrees, Tilt: +90 degrees to -30 degrees
Preset Positions	16 (internal), 6 recalled via IR Remote
Control Methods	RS-232, IR Remote Commander and OSD (on screen display)
Tally Light	Available through RS-232 Control
HD Video Select	16-Position Rotary Switch: Used to set HD Video Resolution Output
Camera Settings	10-Position Dip Switch: Settings for IR Select, Baud Rate 9600, Image Flip and Color Space
Accessory Slot Cards	HD-SDI Slot Card, Part Number 998-6900-007 (3Gb/s Single Link) EZIM CCU Slot Card, Part Number 998-6900-006
Dimensions/Weight	7.81" (198.37mm) H x 6.67" (169.42mm) W x 7.057" (179.25. mm) D / 5.6 lbs. (2.630835643 kg.)
Quick-Connect USB Interface	
Video Outputs	USB 2.0 (MJPEG): Resolution up to 720p/30 (USB 2.0 MJPEG) H.264 (IP) on Ethernet: Resolution up to 1080p/30 (H.264 over IP) Analog Component (YPbPr): Resolution up to 1080p/60 HDMI: Resolution up to 1080p/60
Connectors	1. Power: 5.5mm OD x 2.5mm ID Coaxial Connector 2. YPbPr: DE-15 (15-pinHD) Female 3. HDMI: HDMI Female 4. RS-232 IN: RJ-45 Jack 5. RS-232 OUT: RJ-45 Jack 6. EZ-Power Video: RJ-45 Jack (Power and Differential HD Video)
Cat-5e Cabling/Max. Distance	Two (2) Cat-5e cables (EZ-Power Video and RS-232) Max Distance up to 100' (30.48m)
Power Supply	24 VDC, 2.08 Amp Switching Power Supply
Dimensions/Weight	½-Rack Size - 8.375" (212.73mm) W x 6.0" (152.4mm) x 1.72" (43.688mm) H, 1.4 lbs. (0.635kg)
Accessory	Rack Mount Adapter: 998-6000-004 - 1-RU Offset mount (1-Long ear & 1-Short Ear)

Notes: Specifications and pricing are subject to change without prior notice or obligation.
For dimensional drawings of the products, go to support.vaddio.com and click on drawings.

COMPLIANCE AND CE DECLARATION OF CONFORMITY - CLEARVIEW HD-20SE

Compliance testing was performed to the following regulations:

- **FCC Part 15** (15.107, 15.109), **Subpart B**
- **ICES-003, Issue 4: 2004**
- **EN 55022 A: 2006 + A1: 2007**
- **KN24 2008 (CISPR 24: 1997 + A1: 2000 + A2: 2002)**
- **KN22 2008 (CISPR 22: 2006)**
- **EMC Directive 2004/108/EC**
- **EN 55024: A2: 2003**

Class A
Class A
Class A
Class A
Class A
Class A
Class A



FCC Part 15 Compliance

This equipment has been tested and found to comply with the limits for a Class A digital device, pursuant to Part 15, Subpart B, of the FCC Rules. These limits are designed to provide reasonable protection against harmful interference when the equipment is operated in a commercial environment. This equipment generates, uses, and can radiate radio frequency energy and, if not installed and used in accordance with the instruction manual, may cause harmful interference to radio communications. Operation of this equipment in a residential area is likely to cause harmful interference in which case the user will be required to correct the interference at his/her own expense.

Operation is subject to the following two conditions: (1) This device may not cause interference, and (2) This device must accept any interference including interference that may cause undesired operation of the device.

Changes or modifications not expressly approved by Vaddio can affect emission compliance and could void the user's authority to operate this equipment.



ICES-003 Compliance

This digital apparatus does not exceed the Class A limits for radio noise emissions from digital apparatus set out in the Radio Interference Regulations of the Canadian Department of Communications.

Le présent appareil numérique n'émet pas de bruits radioélectriques dépassant les limites applicables aux appareils numériques de la classe A prescrites dans le Règlement sur le brouillage radioélectrique édicté par le ministère des Communications du Canada.



European Compliance

This product has been evaluated for Electromagnetic Compatibility under the EMC Directive for Emissions and Immunity and meets the requirements for a Class A digital device. In a domestic environment this product may cause radio interference in which case the user may be required to take adequate measures.

Standard(s) To Which Conformity Is Declared:

EMC Directive 2004/108/EC

EN 55022 A: 2006 + A1: 2007(CISPR 22:2005/A1:2005)

EN 55024: 1998 + Amendments A1: 2001 + A2: 2003

- EN 61000-4-2: 1995 + Amendments A1: 1998 + A2: 2001
- EN 61000-4-3: 2006 + A1: 2008
- EN 61000-4-4: 2004 + Corrigendum 2006
- EN 61000-4-5: 2006
- EN 61000-4-6: 2009
- EN 61000-4-8: 2010
- EN 61000-4-11: 2004

KN24 2008 (CISPR 24: 1997 + A1: 2000 + A2: 2002)

- EN 61000-4-2
- EN 61000-4-3
- EN 61000-4-4
- EN 61000-4-5
- EN 61000-4-6
- EN 61000-4-8
- EN 61000-4-11

IEC 60950-1:2005 (2nd Edition); Am 1:2009

EN 60950-1:2006+A11:2009+A1:2010+A12:2011

Radiated and Conducted Emissions

Immunity

Electrostatic Discharge

Radiated Immunity

Electrical Fast Transients

Surge Immunity

Conducted Immunity

Power Frequency Magnetic Field

Voltage Dips, Interrupts and Fluctuations

IT Immunity Characteristics

Electrostatic Discharge

Radiated Immunity

Electrical Fast Transients

Surge Immunity

Conducted Immunity

Power Frequency Magnetic Field

Voltage Dips, Interrupts and Fluctuations

Safety

Safety

COMPLIANCE AND CE DECLARATION OF CONFORMITY - QUICK-CONNECT USB INTERFACE

Compliance testing was performed to the following regulations:

- **FCC Part 15 (15.107, 15.109), Subpart B**
- **ICES-003, Issue 4: 2004**
- **EN 55022 A: 2006 + A1: 2007**
- **EMC Directive 2004/108/EC**
- **EN 55024: A2: 1998 + Amendments A1: 2001 + A2: 2003**

- Class A
- Class A
- Class A
- Class A
- Class A



FCC Part 15 Compliance

This equipment has been tested and found to comply with the limits for a Class A digital device, pursuant to Part 15, Subpart B, of the FCC Rules. These limits are designed to provide reasonable protection against harmful interference when the equipment is operated in a commercial environment. This equipment generates, uses, and can radiate radio frequency energy and, if not installed and used in accordance with the instruction manual, may cause harmful interference to radio communications. Operation of this equipment in a residential area is likely to cause harmful interference in which case the user will be required to correct the interference at his/her own expense.

Operation is subject to the following two conditions: (1) This device may not cause interference, and (2) This device must accept any interference including interference that may cause undesired operation of the device. Changes or modifications not expressly approved by Vaddio can affect emission compliance and could void the user's authority to operate this equipment.



ICES-003 Compliance

This digital apparatus does not exceed the Class A limits for radio noise emissions from digital apparatus set out in the Radio Interference Regulations of the Canadian Department of Communications.
 Le présent appareil numérique n'émet pas de bruits radioélectriques dépassant les limites applicables aux appareils numériques de la classe A prescrites dans le Règlement sur le brouillage radioélectrique édicté par le ministère des Communications du Canada.



European Compliance

This product has been evaluated for Electromagnetic Compatibility under the EMC Directive for Emissions and Immunity and meets the requirements for a Class A digital device. In a domestic environment this product may cause radio interference in which case the user may be required to take adequate measures.

Standard(s) To Which Conformity Is Declared:

- EMC Directive 2004/108/EC**
- EN 55022 A: 2006 + A1: 2007(CISPR 22:2005/A1:2005)**
- EN 55024: A2: 1998 + Amendments A1: 2001 + A2: 2003**
- EN 61000-4-2: 1995 + Amendments A1: 1998 + A2: 2001
- EN 61000-4-3: 2006 + A1: 2008
- EN 61000-4-4: 2004 + Corrigendum 2006
- EN 61000-4-5: 2006
- EN 61000-4-6: 2009
- EN 61000-4-8: 2010
- EN 61000-4-11: 2004
- IEC 60950-1: 2005 2nd Edition); AM 1: 2009**
- EN 60950-1: 2006 + A11: 2009 + A1: 2010 + A12:2011**

- Class A
- Immunity
- Electrostatic Discharge
- Radiated Immunity
- Electrical Fast Transients
- Surge Immunity
- Conducted Immunity
- Power Frequency Magnetic Field
- Voltage Dips, Interrupts and Fluctuations
- Safety
- Safety

WARRANTY INFORMATION

(See Vaddio Warranty, Service and Return Policies posted on vaddio.com for complete details):

Hardware* Warranty: Two (2) year limited warranty on all parts and labor for Vaddio manufactured products. Vaddio warrants its manufactured products against defects in materials and workmanship for a period of two years from the day of purchase, to the original purchaser, if Vaddio receives notice of such defects during the warranty. Vaddio, at its option, will repair or replace products that prove to be defective. Vaddio manufactures its hardware products from parts and components that are new or equivalent to new in accordance with industry standard practices.

Exclusions: The above warranty shall not apply to defects resulting from improper or inadequate maintenance by the customer, customers applied software or interfacing, unauthorized modifications or misuse, mishandling, operation outside the normal environmental specifications for the product, use of the incorrect power supply, modified power supply or improper site operation and maintenance. OEM products and products manufactured by other companies are excluded and are covered by the manufacturer's warranty.

Vaddio Customer Service: Vaddio will test, repair, or replace the product or products without charge if the unit is under warranty. If the product is out of warranty, Vaddio will test then repair the product or products. The cost of parts and labor charge will be estimated by a technician and confirmed by the customer prior to repair. All components must be returned for testing as a complete unit. Vaddio will not accept responsibility for shipment after it has left the premises.

Vaddio Technical Support: Vaddio technicians will determine and discuss with the customer the criteria for repair costs and/or replacement. Vaddio Technical Support can be contacted through one of the following resources: e-mail support at support@vaddio.com or online at vaddio.com.

Return Material Authorization (RMA) Number: Before returning a product for repair or replacement request an RMA from Vaddio's technical support. Provide the technician with a return phone number, e-mail address, shipping address, product serial numbers and original purchase order number. Describe the reason for repairs or returns as well as the date of purchase. See the General RMA Terms and Procedures section for more information. RMA's are valid for 30 days and will be issued to Vaddio dealers only. End users must return products through Vaddio dealers. Include the assigned RMA number in all correspondence with Vaddio. Write the assigned RMA number clearly on the shipping label of the box when returning the product. All products returned for credit are subject to a restocking charge without exception.

Voided Warranty: The warranty does not apply if the original serial number has been removed or if the product has been disassembled or damaged through misuse, accident, modifications, use of incorrect power supply, use of a modified power supply or unauthorized repair.

Shipping and Handling: Vaddio will not pay for inbound shipping transportation or insurance charges or accept any responsibility for laws and ordinances from inbound transit. Vaddio will pay for outbound shipping, transportation, and insurance charges for all items under warranty but will not assume responsibility for loss and/or damage by the outbound freight carrier. If the return shipment appears damaged, retain the original boxes and packing material for inspection by the carrier. *Contact your carrier immediately.*

Products not under Warranty: Payment arrangements are required before outbound shipment for all out of warranty products.

Other General Information:

Care and Cleaning

Do not attempt to take this product apart at any time. There are no user-serviceable components inside.

- Do not spill liquids in the product
- Keep this device away from food and liquid
- For smears or smudges on the product, wipe with a clean, soft cloth
- Use a quality lens cleaner on the lens
- Do not use any abrasive chemicals.

Operating and Storage Conditions:

Do not store or operate the device under the following conditions:

- Temperatures above 40°C (104°F) or temperatures below 0°C (32°F)
- High humidity, condensing or wet environments
- In inclement weather
- In swimming pools or in a hadron collider
- Dry environments with an excess of static discharge
- In orbit (re-entry problem)
- Under severe vibration

APPENDIX 1: YPbPr VIDEO PIN-OUT FOR THE HD-20SE CAMERA

Pin	YPbPr
1	Pr
2	Y
3	Pb
4	-
5	-
6	Pr GND
7	Y GND
8	Pb GND
9	-
10	GND
11	-
12	-
13	-
14	-
15	-

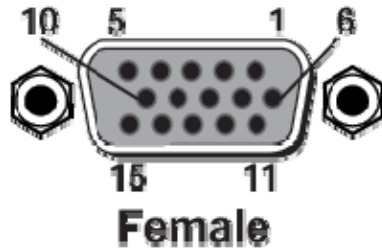

EZ-POWER VIDEO RJ-45 Connector Pin-outs



Important Note: The EZ-POWER VIDEO RJ-45 Connector is for use with the **Quick-Connect SR, Quick-Connect DVI/HDMI SR** and **Quick-Connect USB Interfaces ONLY** (568B Wiring Standard). The video signals are differential (HSDS™) and can only be received by the interfaces above.

Pin	YPbPr
1	Power+
2	Power-
3	Y+
4	PB+
5	PB -
6	Y -
7	PR+
8	PR-

EZ-POWER VIDEO

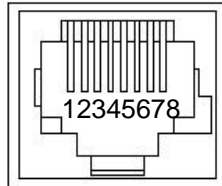

Drawing: ClearVIEW HD-20se Dimensions

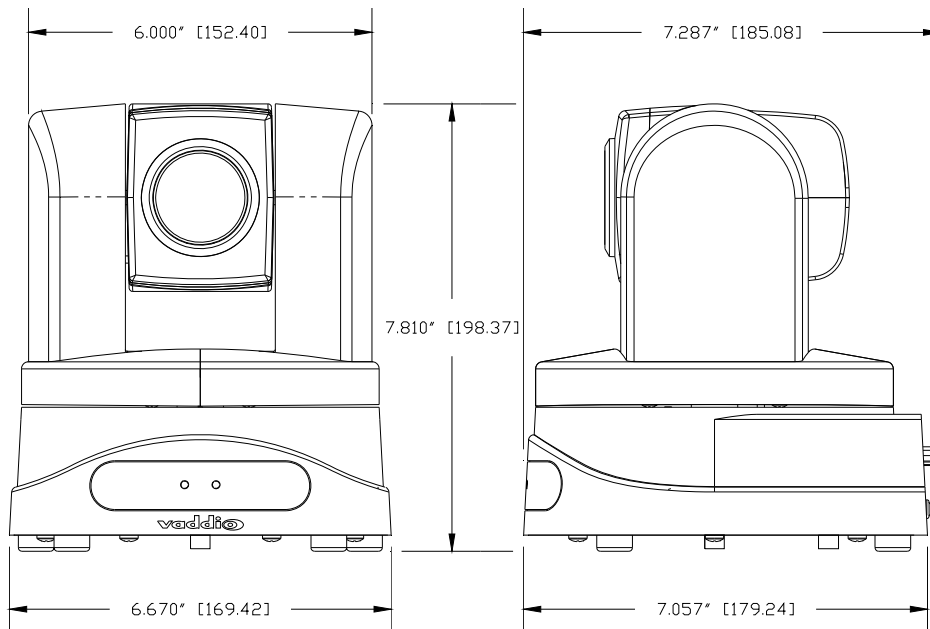

APPENDIX 1: PIN-OUTS FOR EZ-POWER VIDEO CAMERAS AND QUICK-CONNECT USB

Table: EZ-POWER VIDEO RJ-45 Connector Pin-outs

EZ-POWER VIDEO Port

Pin	Signal
1	Power+
2	Power-
3	Y+
4	PB+
5	PB -
6	Y -
7	PR+
8	PR-

EZ-POWER VIDEO

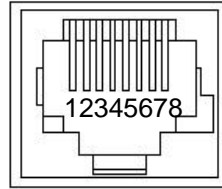

Important Note: The EZ-POWER VIDEO RJ-45 Connector on a Vaddio CAT-5 system camera is for use with the Quick-Connect SR, Quick-Connect DVI/HDMI SR, Quick-Connect USB and USB Mini Interfaces ONLY (568B Wiring Standard). The video signals are differential (HSDS) and can only be processed by the interfaces above.

Table: Camera RS-232 Port

Pin #	Camera Pins	Quick-Connect USB
Pin - 1	N/A	
Pin - 2	N/A	
Pin - 3	N/A	
Pin - 4	Not Used with QC-USB	
Pin - 5	Not Used with QC-USB	
Pin - 6	Digital GND	
Pin - 7	RXD (from TXD of control source)	
Pin - 8	TXD (to RXD of control source)	

RS-232

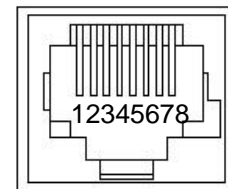
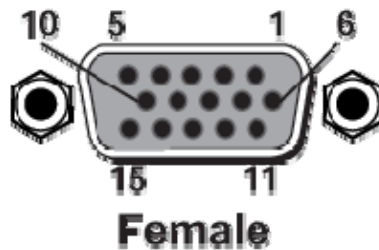

Table: Quick-Connect USB DE-15 Pin-Output (Analog Component YPbPr)

Pin	YPbPr
1	Pr
2	Y
3	Pb
4	-
5	-
6	Pr GND
7	Y GND
8	Pb GND
9	-
10	GND
11	-
12	-
13	-
14	-
15	-



COMMUNICATION SPECIFICATION

Communication Speed: 9600 bps (default)
 Start bit: 1
 Stop bit: 1
 Data bits: 8
 Parity: None
 No Flow control

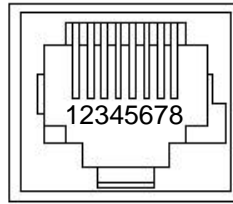

Pin #	RJ-45 RS-232 and IR Out Pins
1)	Unused
2)	Unused
3)	Unused
4)	Unused
5)	Unused
6)	GND (GND of IR Short Range - Pin 3)
7)	RXD (from TXD of control source)
8)	TXD (to RXD of control source)

NOTE: The Vaddio ClearVIEW HD-20SE Control Protocol is similar, but not identical to, the Sony® VISCA™ command set in order to be compatible with several popular control devices. Not all VISCA commands are supported and there are many HD-Series specific commands in the following Command and Inquiry Lists.

HD-20se Command List (1/2)

Command Set	Command	Command Packet	Comments
Address Set	Broadcast	88 30 01 FF	Address Set (Daisy chain)
IF_Clear	Broadcast	88 01 00 01 FF	IF Clear
Command Cancel		8x 2p FF	p:socket number(1,2)
CAM_Power	On	8x 01 04 00 02 FF	Power On/Off
	Off(Standby)	8x 01 04 00 03 FF	
CAM_Zoom	Stop	8x 01 04 07 00 FF	pqrs: Zoom Position* v:(Speed) 0-7
	Tele(Standard)	8x 01 04 07 02 FF	
	Wide(Standard)	8x 01 04 07 03 FF	
	Tele(Variable)	8x 01 04 07 2p FF	
	Wide(Variable)	8x 01 04 07 3p FF	
	Direct	8x 01 04 47 0p 0q 0r 0s FF	
CAM_Focus	Direct(Variable)	8x 01 7E 01 4A 0v 0p 0q 0r 0s FF	pqrs: Focus position*
	Stop	8x 01 04 08 00 FF	
	Far(Standard)	8x 01 04 08 02 FF	
	Near(Standard)	8x 01 04 08 03 FF	
	Far(Variable)	8x 01 04 08 2p FF	
	Near(Variable)	8x 01 04 08 3p FF	
	AutoFocus	8x 01 04 38 02 FF	
	ManualFocus	8x 01 04 38 03 FF	
Auto/Manual	8x 01 04 38 10 FF		
CAM_WB	Direct	8x 01 04 48 0p 0q 0r 0s FF	
	Auto	8x 01 04 35 00 FF	
	Manual	8x 01 04 35 05 FF	
	Indoor	8x 01 04 35 01 FF	
	Outdoor	8x 01 04 35 02 FF	
CAM_RGain	One Push WB	8x 01 04 35 03 FF	
	Reset	8x 01 04 03 00 FF	
	Up	8x 01 04 03 02 FF	
	Down	8x 01 04 03 03 FF	
CAM_BGain	Direct	8x 01 04 43 0p 0q 0r 0s FF	pqrs:00-0xffff
	Reset	8x 01 04 04 00 FF	
	Up	8x 01 04 04 02 FF	
	Down	8x 01 04 04 03 FF	
CAM_AE	Direct	8x 01 04 44 43 0p 0q 0r 0s FF	pqrs:00-0xffff
	Reset	8x 01 04 39 00 FF	
	Manual	8x 01 04 39 03 FF	
	Shutter Priority	8x 01 04 39 0A FF	
CAM_Iris	Iris Priority	8x 01 04 39 0B FF	pqrs:00-0xffff
	Reset	8x 01 04 0B 00 FF	
	Up	8x 01 04 0B 02 FF	
	Down	8x 01 04 0B 03 FF	
CAM_Gain	Direct	8x 01 04 4B 00 00 0p 0q FF	pq(0x00-0x08)
	Reset	8x 01 04 0C 00 FF	
	Up	8x 01 04 0C 02 FF	
	Down	8x 01 04 0C 03 FF	
CAM_Bright	Direct	8x 01 04 4C 00 00 0p 0q FF	pq(0x00-0x2A)
	Reset	8x 01 04 0D 00 FF	
	Up	8x 01 04 0D 02 FF	
	Down	8x 01 04 0D 03 FF	
CAM_Bright	Direct	8x 01 04 4D 00 00 0p 0q FF	pq(0x01-0x64)
	Reset	8x 01 04 0D 00 FF	
	Up	8x 01 04 0D 02 FF	
	Down	8x 01 04 0D 03 FF	

HD-20se Command List (2/2)

Command Set	Command	Command Packet	Comments
CAM_Backlight	On Off	8x 01 04 33 02 FF 8x 01 04 33 03 FF	
CAM_Aperture	Reset Up Down Direct	8x 01 04 02 00 FF 8x 01 04 02 02 FF 8x 01 04 02 03 FF 8x 01 04 42 00 00 0p 0q FF	pq(0x00-0x1F)
CAM_Memory	Reset Set Recall	8x 01 04 3F 00 0p FF 8x 01 04 3F 01 0p FF 8x01 04 3F 02 0p FF	p:Memory No(=0-0xF)
CAM_IDWrite		8x 01 04 22 0p 0q 0r 0s FF	pqrs:0x0000 – 0xFFFF
CAM_LR_Reverse On	On Off	8x 01 04 61 02 FF 8x 01 04 61 03 FF	Mirror (Horizontal) on Mirror (Horizontal) off
IR_Receive##	On Off On/Off	8x 01 06 08 02 FF 8x 01 06 08 03 FF 8x 01 06 08 10 FF	IR forwarding/Local IR
Pan-tiltDrive	Up Down Left Right UpLeft UpRight DownLeft DownRight Stop Absolute Position Home Reset	8x 01 06 01 VV WW 03 01 FF 8x 01 06 01 VV WW 03 02 FF 8x 01 06 01 VV WW 01 03 FF 8x 01 06 01 VV WW 02 03 FF 8x 01 06 01 VV WW 01 01 FF 8x 01 06 01 VV WW 02 01 FF 8x 01 06 01 VV WW 01 02 FF 8x 01 06 01 VV WW 02 02 FF 8x 01 06 01 VV WW 03 03 FF 8x 01 06 02 VV WW 0Y 0Y 0Y 0Y 0Z 0Z 0Z 0Z FF 8x 01 06 04 FF 8x 01 06 05 FF	VV: Pan Speed (0x01-0x18) WW: Tilt Speed(0x01-0x14) YYYY: Pan Position** ZZZZ: Tilt Position**
Pan-tilt-zoom Drive	Up Down Left Right Tele Wide UpLeft UpRight DownLeft DownRight Stop Absolute Position	8x 01 06 0A VV WW XX 03 01 03 FF 8x 01 06 0A VV WW XX 03 02 03 FF 8x 01 06 0A VV WW XX 01 03 03 FF 8x 01 06 0A VV WW XX 02 03 03 FF 8x 01 06 0A VV WW XX 03 03 01 FF 8x 01 06 0A VV WW XX 03 03 02 FF 8x 01 06 0A VV WW XX 01 01 03 FF 8x 01 06 0A VV WW XX 02 01 03 FF 8x 01 06 0A VV WW XX 01 02 03 FF 8x 01 06 0A VV WW XX 02 02 03 FF 8x 01 06 0A VV WW XX 03 03 03 FF 8x 01 06 0B VV WW XX 0Y 0Y 0Y 0Y 0Z 0Z 0Z 0Z 0R 0R 0R 0R FF	VV: Pan Speed (0x01-0x18) WW: Tilt Speed(0x01-0x14) XX: ZoomSpeed(0x00-0x07) YYYY: Pan Position** ZZZZ: Tilt Position** RRRR: ZoomPosition**
Tally	On Off	8x 01 7E 01 0A 00 02 FF 8x 01 7E 01 0A 00 03 FF	
Preset Pan Speed	Pan/Tilt/Zoom Speed	8x 01 7E 01 0B WW SS ZZ FF	WW: Pan Speed (0x01-0x18) SS:Tilt Speed(0x01-0x14) ZZ:Zoom Speed(0-7);
Motor Config	Hard Motor Stops Soft Motor Stops	8x 01 7E 01 70 00 00 FF 8x 01 7E 01 70 00 01 FF	
BLK.Enhance	Pedestal	No Support	No Support
GMA.Enhance	Gamma	8x 01 7E 54 00 00 0p 0q FF	pq: Gamma (0x00-0x10)
CRM.Enhance	Chroma	8x 01 7E 55 00 00 0p 0q FF	pq: Chroma (0x00-0x64)
KNE.Enhance	Knee	No Support	No Support
DIS.Enhance	Digital Image Stabilizer	8x 01 7E 57 02 FF 8x 01 7E 57 03 FF	On Off
SNR.Enhance	Super Noise Reduction	8x 01 7E 58 02 FF 8x 01 7E 58 03 FF	On Off
AGC.Enhance	AGC Mode	8x 01 7E 59 00 FF 8x 01 7E 59 01 FF 8x 01 7E 59 02 FF 8x 01 7E 59 03 FF	Off Low Medium High
CAM_Shutter	Reset Up Down Direct	8x 01 04 0A 00 FF 8x 01 04 0A 02 FF 8x 01 04 0A 03 FF 8x 01 04 4A 00 00 0p 0q FF	pq(0x00-0x1C)
CAM_ExpComp	On Off Reset Up Down Direct	8x 01 04 3E 02 FF 8x 01 04 3E 03 FF 8x 01 04 0E 00 FF 8x 01 04 0E 02 FF 8x 01 04 0E 03 FF 8x 01 04 4E 00 00 0p 0q FF	AutoExposure Off AutoExposure On Pq: 0x00-0x2A
CAM_ICR Cut Filter	ICR On ICR Off	8x 01 04 01 02 FF 8x 01 04 01 03 FF	ICR On - Cut Filter Out ICR Off - Cut Filter In

HD-20se Command List (2/2) Notes

***Zoom and Focus Data:**

CAM_Zoom: Range(0x000-0x071A)
 CAM_Focus: Range (0x0ed-0x0944) dependent on Zoom Position

****Additional Information:**

Pan Range: 8044 – 7FBC (-32,700 to +32,700)
 Tilt Range: E891 – 4C2B (-5,999 to +19,499)
 Actual Pan/Tilt ranges defined in Inquiry list

HD-20se Inquiry List (1/1)



Inquiry Command	Command	Response Packet	Comments
CAM_PowerInq	8x 09 04 00 FF	y0 50 02 FF y0 50 03 FF	On Off(Standby)
CAM_ZoomPosInq	8x 09 04 47 FF	y0 50 0p 0q 0r 0s FF	pqr: 0-0x071A
CAM_FocusPosInq	8x 09 04 48 FF	y0 50 0p 0q 0r 0s FF	pqrs: Focus Position
CAM_WBModelInq	8x 09 04 35 FF	y0 50 00 FF y0 50 05 FF y0 50 01 FF y0 50 02 FF y0 50 03 FF	Auto Manual Indoor Outdoor One Push WB
CAM_RGain	8x 09 04 43 FF	y0 50 0p 0q 0r 0s FF	pqrs: 000-0xffff
CAM_BGain	8x 09 04 44 FF	y0 50 0p 0q 0r 0s FF	pqrs: 000-0xffff
CAM_Iris	8x 09 04 4B FF	y0 50 00 00 0p 0q FF	pq(0x00-0x08)
CAM_Gain	8x 09 04 4C FF	y0 50 00 00 0p 0q FF	pq(0x00-0x2A)
CAM_Bright	8x 01 04 4D FF	y0 50 00 00 0p 0q FF	pq(0x01-0x64)
CAM_BacklightModelInq	8x 09 04 33 FF	y0 50 02 FF y0 50 03 FF	On Off
CAM_ApertureInq	8x 09 04 42 FF	y0 50 00 00 0p 0q FF	Pq:x00-0x1F
CAM_MemoryInq	8x 09 04 3F FF	y0 50 0p FF	p: Preset 0-0xf
CAM_IDInq	8x 09 04 3F FF	y0 50 0p 0q 0r 0s FF	pqrs: 0x0000 – 0xFFFF
CAM_ReceiveInq	8x 09 06 08 FF	y0 50 02 FF y0 50 03 FF	On Off
CAM_LR_Reverse	8x 09 04 61 FF	y0 50 02 FF y0 50 03 FF	On Off
Pan-TiltMaxSpeedInq	8x 09 06 11 FF	y0 50 pp qq FF	pp: Pan 0x01-0x18 qq: Tilt 0x01-0x14
Pan-tiltPositionInq	8x 09 06 12 FF	FF y0 50 0p 0p 0p 0p 0q 0q 0q 0q FF	pppp: Pan 0x8044-0x7FB2 qqqq: Tilt 0xE890-0x4C2C
TallyInq	8x 09 7E 01 0A FF	y0 50 02 FF y0 50 03 FF	On Off
PresetSpeedInq	8x 09 7E 01 0B FF	y0 50 pp qq rr FF	pp: Pan 0x01-0x18 qq: Tilt 0x01-0x14 rr: Zoom 0x00-0x07
Motor Config	8x 09 7E 01 70 FF	y0 50 00 FF y0 50 01 FF	Hard Motor Stops Soft Motor Stops
BLK.Enhance	No support	No Support	Pedestal
GMA.Enhance	8x 09 7E 54 FF	y0 50 00 00 0p 0q FF	pq: Gamma (0x00-0x10)
CRM.Enhance	8x 09 7E 55 FF	y0 50 00 00 0p 0q FF	pq: Chroma (0x00-0x64)
KNE.Enhance	No support	No Support	Knee
DIS.Enhance	8x 09 7E 57 FF	y0 50 02 FF y0 50 03 FF	On Off
SNR.Enhance	8x 09 7E 58 FF	y0 50 02 FF y0 50 03 FF	On Off
AGC.Enhance	8x 09 7e 59 FF	y0 50 00 FF y0 50 01 FF y0 50 02 FF y0 50 03 FF y0 50 04 FF	Off Low Medium High Manual AGC
CAM_AEModelInq	8x 09 04 39 FF	y0 50 00 FF y0 50 03 FF y0 50 0A FF y0 50 0B FF	Auto Exposure Mode Manual Control Mode Shutter Priority Mode Exposure Priority Mode
CAM_ShutterPosInq	8x 09 04 4A FF	y0 50 00 00 0p 0q FF	pq: 0x0-0x1C
CAM_ExpCompModelInq	8x 09 04 3E FF	y0 50 02 FF y0 50 03 FF	On - AE Mode Off Off – AE Mode On
CAM_ExpCompPosInq	8x 09 04 4E FF	y0 50 00 00 0p 0q FF	pq: ExpComp Pos
CAM_ICRModelInq	8x 09 04 01 FF	y0 50 02 FF y0 50 03 FF	On - ICR filter Out Off – ICR filter In

TABLE: HD-20SE OSD MENU STRUCTURE

Use this OSD menu with the IR Commander to make video adjustments (AWB, COLOR, EXP, etc...) on the HD-20SE Camera.

Menu	Controls	Modes/Range	Default	Notes
SSDR	OFF		OFF	Dynamic Range Adjustment
	ON	SSDR 0-15	8*	*When Dynamic Range is ON
	Return			Return to Main Menu
WHITE BAL	ATW		ON	Auto White Balance - ON
	MANUAL>	RED 0 - 1000	560	Adjust Red Level
		BLUE 0 - 1000	480	Adjust Blue Level
		RETURN<		Return to WHITE BAL Menu
	AWC-SET			
	OUTDOOR			
	INDOOR			
	MERCURY			
	SODIUM			
	RETURN<			Return to Main Menu
BACKLIGHT	OFF		OFF	Default BLC is off
	WDR>	LEVEL (LOW / MED / HIGH)	OFF	Wide Dynamic Range
		RETURN<		
	BLC>	LEVEL (LOW / MED / HIGH)	OFF	
		BOTTOM 1-100		
		LEFT 1-100		
		RIGHT 1-100		
		RETURN<		Return to BACKLIGHT Menu
	HLC>	LEVEL (LOW / MED / HIGH)	OFF	
		MASK TONE 1-15		
	RETURN<		Return to BACKLIGHT Menu	
	RETURN<		Return to Main Menu	
INTELLIGENCE	OFF	Intelligence, motion detection analytics and masking are not processed or used by the HD-20SE camera, however the OSD menu still works.		
FOCUS	MODE	AUTO / MANUAL / ONE PUSH	AUTO	
	ZOOM TRACK>	OFF / TRACK / AUTO TRACK	AUTOTRACK	
	ZOOM SPEED>	SLOW / MEDIUM / FAST		
	DIGITAL ZOOM>	OFF/ON	OFF	Default is OFF
		ON>LIMIT X2 - X16		Avoid Digital Zoom if possible
		RETURN<		Return to FOCUS Menu
	Zoom POS INIT>	OFF/AUTO		Zoom position initialization
		MANUAL>		
		POS INIT 1X - 20X	1X	Sets INIT Zoom Position
		RETURN<		Return to FOCUS Menu
	USER PRESET>	OFF/ON	OFF	
		ON > PRESET NO 1-128	1	Zoom Presets
		PRESET SAVE		
	PRESET CLEAR			
	RETURN<		Return to FOCUS Menu	
LENS INIT	MANUAL / AUTO			
RETURN<			Return to Main Menu	
EXPOSURE	BRIGHTNESS	0-100	50	Brightness Sets Luminance Target
	IRIS>	AUTO	AUTO	Automatic Gain Control
		MANUAL>	Closed to F28	Manual Iris
		RETURN<		Return to EXPOSURE Menu
	SHUTTER	A FLK		Anti-Flicker
		ESC		
		MANUAL> 1/30 - 1/30,000 sec.		Shutter Speed
		RETURN<		Return to EXPOSURE Menu
	AGC	OFF / LOW / MED / HIGH	LOW	
		MANUAL (OFF)>		
		AGC VALUE 0 - 36dB	0 dB	Automatic Gain Control
	RETURN<			
SSNR	OFF / LOW / MED / HIGH	LOW	Noise Reduction - Don't use above Low	
SENS-UP	OFF	OFF	OFF - Do not Use	
RETURN<			Return to Main Menu	

OSD Menu Structure (continued)

Menu	Controls	Range/Modes	Default	Notes
SPECIAL	DAY/NIGHT>	COLOR / B/W / AUTO	COLOR	Do not use
	DIS>	OFF / ON	OFF	Digital Image Stabilization - leave off
	DEFOG	OFF / ON / MANUAL/AUTO	OFF	Do not use
	COMM ADJUST>	BAUD RATE	NEVER CHANGE THE BAUD RATE OR THE UART SETTINGS - Control is lost if these are changed. Factory default reboot will be required. 	
		UART		
		RETURN<		Return to SPECIAL Menu
	IMAGE ADJUST>	H-REV ON / OFF	OFF	Use Dip Switch on Camera to Flip Image
		V-REV ON / OFF	OFF	Use Dip Switch on Camera to Flip Image
		SHARPNESS ON/OFF	ON	Picture Detail
		ON> 0-30	15	
		RETURN<		Return to IMAGE ADJUST Menu
		MONITOR LCD>		
		GAMMA .0 -1.0	0.50	
		COLOR LEVEL 0-100	50	
		RETURN<		Return to IMAGE ADJUST Menu
		USER>		
		GAMMA .0 - 1.0	0.50	
		COLOR LEVEL 0-100	50	
		RETURN<		Return to IMAGE ADJUST Menu
		RETURN<		Return to Main Menu
	DISPLAY	CAM TITLE ON / OFF	OFF	
		ON> A-Z, 1-9		
		RETURN<		Return to DISPLAY Menu
		CAM ID ON / OFF	OFF	
		CAM INFO ON / OFF	OFF	
		ZOOM MAG ON/OFF	OFF	
		OSD COLOR	WHITE	WHITE/YELLOW/GREEN/RED/BLUE
		LANGUAGE	ENGLISH	(ENG, FR, KOR, SP, CHIN, JAP, PORT, RUS, DUT, ITAL)
		SET LANGUAGE		
		RETURN<		Return to Main Menu
	VIDEO OUT FORM	COMPONENT ON / OFF	ON	Do not change this parameter
		RETURN<		Do not change resolutions here - Use the Rotary Switch on the back of the camera
RESET				
EXIT				

QUICK-CONNECT USB TELNET SERIAL COMMAND API

The Vaddio Serial Command protocol is a high level text based command line interface supported via telnet session on the Quick-Connect USB. The command application protocol interface is intended to allow external device such as Crestron or AMX device to control the Quick-Connect USB and the camera attached. The protocol is based upon ASCII format following the VT100 terminal emulation standard and uses an intuitive text command nomenclature for ease of use. The API is accessed by a telnet client on the Ethernet port. All ASCII characters will be **echoed** to terminal program and appended with VT100 string **-ESC[J** (HEX- 1B 5B 4A). Vaddio Command lines are terminated on carriage return. After the carriage return, the VT100 appends with **-ESC[J**. (**Note:** Most terminal programs automatically strip the VT100 string.) General format usage follows a **get/set** structure. Usage examples for each type are:

Set Example

COMMAND: > camera pan right
RESPONSE: > OK

Get Example

COMMAND: > camera home get
RESPONSE: > OK

Syntax Error Example

COMMAND: > camera right pan
RESPONSE: > ERROR

Additional programming controls associated with the terminal protocol includes:

- **CTRL 5** - Clears the current serial buffer on the device.

Notes: Telnet sessions will require access verification and uses the same username and password associated with the Administrator account on the embedded web server. The default Telnet Port is 23. Command lines are terminated with a carriage return.

Telnet Command List

Camera Home

NAME

camera home - Move the camera to the home position

SYNOPSIS

camera home

DESCRIPTION

Method used to move the camera to the home position

EXAMPLES

camera home - Moves the camera back to the home position

Camera Pan

NAME

camera pan - Pans the camera left or right

SYNOPSIS

camera pan {left|right|stop} [1-24]

DESCRIPTION

Method used to pan the camera

OPTIONS

left - Moves the camera left

right - Moves the camera right

stop - Stops the camera movement

speed - Optional integer from 1-24 that represents the speed (Default: 12)

EXAMPLES

camera pan left - Pans the camera left at the default speed

camera pan right 20 - Pans the camera right using a speed of 20

camera pan stop - Stops the pan movement of the camera



Image: Invigorating simulated Telnet session.

Camera Preset

NAME

camera preset - Recall and storing of camera presets

SYNOPSIS

camera preset {recall|store} [1-6]

DESCRIPTION

Method used to recall and store camera presets

OPTIONS

recall - Recalls preset

store - Stores preset

preset - Required value from 1-6 used to indicate the preset number

EXAMPLES

camera recall 3 - Moves camera to preset position 3

camera store 1 - Store current camera position as preset 1

Camera Tilt

NAME

camera tilt - Tilts the camera up or down

SYNOPSIS

camera tilt {up|down|stop} [1-20]

DESCRIPTION

Method used to tilt the camera

OPTIONS

up - Moves the camera up

down - Moves the camera down

stop - Stops the camera movement

speed - Optional integer from 1-20 that represents the speed (Default: 10)

EXAMPLES

camera tilt up - Tilts the camera up at the default speed

camera tilt down 20 - Tilts the camera up using a speed of 20

camera tilt stop - Stops the tilt movement of the camera

Camera Zoom

NAME

camera zoom - Zoom the camera in or out

SYNOPSIS

camera zoom {in|out|stop} [1-7]

DESCRIPTION

Method used to zoom the camera

OPTIONS

in - Zoom in

out - Zoom out

stop - Stop the camera movement

speed - Optional integer from 1-7 that represents the speed (Default: 3)

EXAMPLES

camera zoom in - Zooms the camera in at the default speed

camera zoom out 7 - Zooms the camera out using a speed of 7

camera zoom stop - Stops the zoom movement of the camera

Camera

NAME

camera - Base command for camera control.

Used in conjunction with control arguments to include home, pan, tilt, zoom, and preset.



Exit

NAME

exit - ends the current API command session

SYNOPSIS

exit

DESCRIPTION

Exit ends the current API command session. If the session is over telnet, the session is ended and the socket is closed. If the session is over serial, a new session is started.

Help

NAME

help - display an overview of the CLI syntax

SYNOPSIS

help

DESCRIPTION

Display an overview of the command line syntax

History

NAME

history - command history

SYNOPSIS

history [limit]

DESCRIPTION

Since many of the programs read user input a line at a time, the command history is used to keep track of these lines and also recall historic information

HISTORY NAVIGATION

The command history can be navigated using the up and down arrow keys. The up arrow will move up a single entry in the command history while the down arrow moves down in the command history.

HISTORY EXPANSION

The command history supports the expansion functionality from which previous commands can be recalled from within a single session. History expansion is performed immediately after a complete line is read.

Listed below are examples of history expansion:

- * !! Substitute the last command line.
- * !N Substitute the Nth command line (absolute as per 'history' command)
- * !-N Substitute the command line entered N lines before (relative)

EXAMPLES

History - Displays the current command buffer

history 5 - Sets the history command buffer to remember the last 5 unique entries

Network Ping

NAME

network ping - send ICMP ECHO_REQUEST to network hosts

SYNOPSIS

network ping [count <count>] [size <size>] <destination-ip>

DESCRIPTION

Use the ICMP protocol's mandatory ECHO_REQUEST datagram to elicit an ICMP ECHO_RESPONSE from a host or gateway. ECHO_REQUEST datagrams have an IP and ICMP header, followed by a struct timeval and then an arbitrary number of pad bytes used to fill out the packet.

OPTIONS

count - Stop after sending count ECHO_REQUEST packets. With deadline option, ping waits for count ECHO_REPLY packets, until the timeout expires. The default is 5.

destination - The destination IP address where the ECHO_REQUESTS are sent

size - The data size of the ICMP packet to send. The default is 56 bytes

EXAMPLES

network ping 192.168.1.1 - Attempt to send 5 ICMP ECHO_REQUESTs with data size 56 to the host at 192.168.1.1

network ping count 10 size 100 192.168.1.1 - Attempt to send 10 ICMP ECHO_REQUESTs with data size of 100 to the host at 192.168.1.1

Network Settings

NAME

network settings - get current network settings

SYNOPSIS

network settings {get}

DESCRIPTION

Method used to get the current network settings of the device

OPTIONS

get Get the current network settings for the machine

EXAMPLES

network settings get

Returns the current network settings for MAC address, IP address, Netmask, and Gateway

MAC Address: 00:04:a3:85:0a:ee

IP Address: 10.10.8.116

Netmask: 255.255.255.0

Gateway: 10.10.8.100

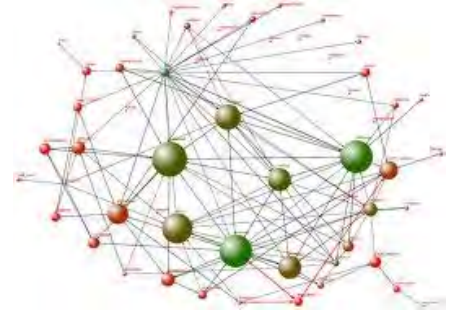

Network

NAME

network - Gets the current network settings or pings an IP address

SYNOPSIS

network {settings get | ping [count <count>] [size <size>] <destination-ip>}

DESCRIPTION

Method used to get the current network settings or check network

OPTIONS

Settings - Get the current network settings

ping - Send ICMP ECHO_REQUEST to network host

EXAMPLES

network settings get - Gets the current network settings

network ping count 1 10.10.10.100 - Pings 10.10.10.100 once and displays results

Streaming Mode

NAME

streaming mode - Gets or sets the current streaming mode

SYNOPSIS

streaming mode {get|usb|network}

DESCRIPTION

Method used to get or set the current streaming settings

OPTIONS

Get - Gets the current streaming mode

usb - Set the current streaming mode to USB

Ethernet - Set the current streaming mode to Ethernet

EXAMPLES

streaming mode get

mode: usb

Returns the current streaming mode

streaming mode Ethernet

OK

Sets the streaming mode to Ethernet

Streaming Quality

NAME

streaming quality - Gets or sets the current streaming quality

SYNOPSIS

streaming quality {get|low|standard|high}

DESCRIPTION

Method used to get or set the current streaming quality

OPTIONS

get - Get the current streaming quality
 low - Set video quality to low
 standard - Set video quality to standard
 high - Set video quality to high

EXAMPLES

```
streaming quality get
quality:low
Returns the current streaming quality
----
streaming quality standard
OK
Sets the streaming quality to standard
```



Streaming Resolution

NAME

streaming resolution - Gets or sets the current IP streaming quality

SYNOPSIS

streaming resolution {get|1080p|720p|4cif|480p|cif}

DESCRIPTION

Method used to get or set the current streaming resolution

OPTIONS

get - Get the current streaming resolution
 1080p - Sets video resolution to 1080p
 720p - Set video resolution to 720p
 4cif - Sets video resolution to 4cif
 480p - Sets video resolution to 480p
 cif - Sets video resolution to cif

EXAMPLES

```
streaming resolution get
resolution:720p
Returns the current streaming resolution
----
streaming resolution 720p
OK
Sets the streaming resolution to 720p
```

Streaming

NAME

streaming - Gets or sets the current streaming settings

SYNOPSIS

streaming {mode {get|usb|ethernet}} | resolution {get|1080p|720p|4cif|480p|cif} | quality {get|low|standard|high}}

DESCRIPTION

Method used to get or set the current streaming settings

OPTIONS

mode - Get or set the current streaming mode
 resolution - Get or set the current streaming video resolution
 quality - Get or set the current streaming video frame rate and bit rate

EXAMPLES

```
streaming mode get
mode: usb
Returns the current streaming mode
----
streaming mode Ethernet - Sets the streaming mode to Ethernet
streaming quality standard - Sets the streaming quality to standard
streaming resolution 720p - Sets the streaming resolution to 720p
```

System Factory-Reset

NAME

system factory-reset - Gets or sets factory reset status

SYNOPSIS

system factory-reset {get|on|off}

DESCRIPTION

Method used to get or set the factory reset status

OPTIONS

- Get the current factory reset status
- on - Enable factory reset on reboot
- off - Disable factory reset on reboot

EXAMPLES

```
system factory-reset get
factory-reset (software): off
factory-reset (hardware): off
Returns the factory reset status
----
system factory-reset: on
factory-reset (software): on
factory-reset (hardware): off
Enables factory reset upon reboot
```



System Reboot

NAME

system reboot - Reboots system

SYNOPSIS

system reboot [<seconds>]

DESCRIPTION

Method used to reboot system

OPTIONS

Seconds - The number of seconds to delay the reboot

EXAMPLES

```
Reboot - Reboot system immediately
reboot 30 - Reboot the system in 30 seconds
```

System

NAME

system - gets or Sets the Current System Settings

SYNOPSIS

system {factory-reset {get|on|off} | reboot [<seconds>]}

DESCRIPTION

Method used to get/set the current system settings or execute system commands

OPTIONS

- factory-reset - Get or set the factory reset status
- reboot - Reboot the system

EXAMPLES

```
system factory-reset get
factory-reset (software): off
factory-reset (hardware): off
----
system factory-reset on
factory-reset (software): on
factory-reset (hardware): off
----
system reboot
Broadcast message from root
>The system is going down for a reboot NOW!
----
system reboot 30
OK
> The system is going down for a reboot NOW!
```

System Update

NAME

system update - Updates the system given a url to the update file

SYNOPSIS

system update [<url>]

DESCRIPTION

Method used to update the system via a url

OPTIONS

url - The url of the file to be fetched

EXAMPLES

system update <file name>

Update the system using the update file [Version](#)

NAME

version - display the system version information

SYNOPSIS

version

DESCRIPTION

Display an overview of the command line syntax

EXAMPLES

Version

Returns the current software version



205 Westwood Ave, Long Branch, NJ 07740

Phone: 866-94 BOARDS (26273) / (732)-222-1511

Fax: (732)-222-7088 | E-mail: sales@touchboards.com



Inside Rear Cover - Mostly Blank



Toll Free: 800-572-2011 ▪ Phone: 763-971-4400 ▪ FAX: 763-971-4464
www.vaddio.com