

Veris Pulse Output kWh Transducer (Single CT) Connection Instructions

For use with HOBOb[®] H21, H22, U30, UX120 series data loggers, and HOBOb data nodes

Applies to this Veris Pulse Output kWh Transducer:

Onset Part No.	Configuration / VAC	Output	Maximum Pulse Output	Veris Part No.
T-VER-8051-300	Single-phase 120-277 and (balanced) 3-phase 480	Pulses representing kWh	50 Hz	H8051-0300-2



Installing transducer in an energized electrical enclosure or on any energized conductor can result in severe injury or death. This transducer is for installation by qualified personnel only. To avoid electrical shock, do not perform any installation or servicing of this transducer unless you are qualified to do so. Disconnect and lock-out all power sources during installation and servicing. Please read transducer user's manual for instructions and use.

This document provides instructions on connecting the Veris Pulse Output kWh Transducer listed above to HOBOb H21, H22, U30, and UX120 series data loggers and to HOBOb ZW series data nodes. **Note:** For information on connecting the transducer to the power source and other transducer details, refer to the documentation provided by Veris.

Required:

- Veris Pulse Output kWh Transducer listed above
- HOBOb H21, H22, U30, and UX120 series data logger, or HOBOb data node (ZW series)
- Pulse input adapter, Onset Part No. S-UCC-M00x, for H21, H22, and U30 series
- 22 AWG twisted pair wire (customer supplied) for UX120 series
- Adapter cable, Onset Part No. CABLE-2.5-STEREO, for ZW series
- HOBObware[®] Pro software, version 2.2.1 or higher (2.4.0 or higher for U30 series; 3.0 or higher for ZW series; 3.2.0 or higher for UX120 series)



Veris Pulse Output kWh Transducer

Configuring the System:

See the following pages for the applicable connection diagram that corresponds to your electrical power configuration.

Data Interpretation:

The consumed energy in kilowatt-hours (kWh) per pulse is selected on the Veris transducer. The data recorded in the logger or data node will be number of counts (pulses) per logging interval. For conversion to other units, the data must be exported from the HOBObware Pro software. **Note:** For complete information on using HOBObware Pro, refer to the software documentation.

Veris Pulse Output kWh Transducer (Single CT) Connection Instructions

H21, H22, and U30 Typical 120 or 240 VAC Single-Phase Three-Wire Connection

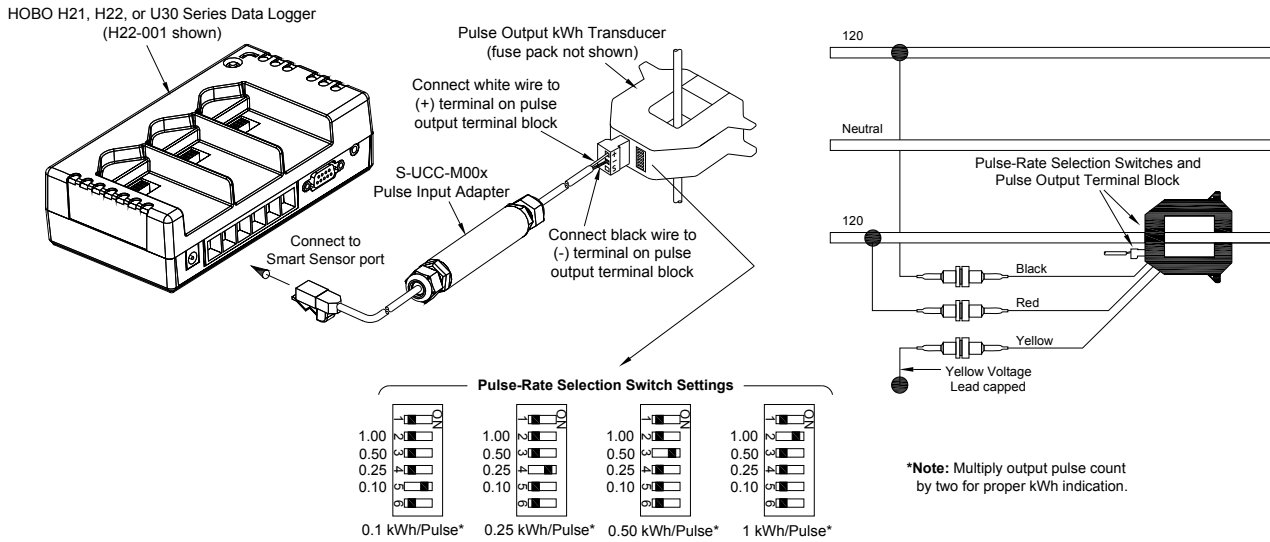

H21, H22, and U30 Typical 277 VAC Single-Phase Two-Wire Connection

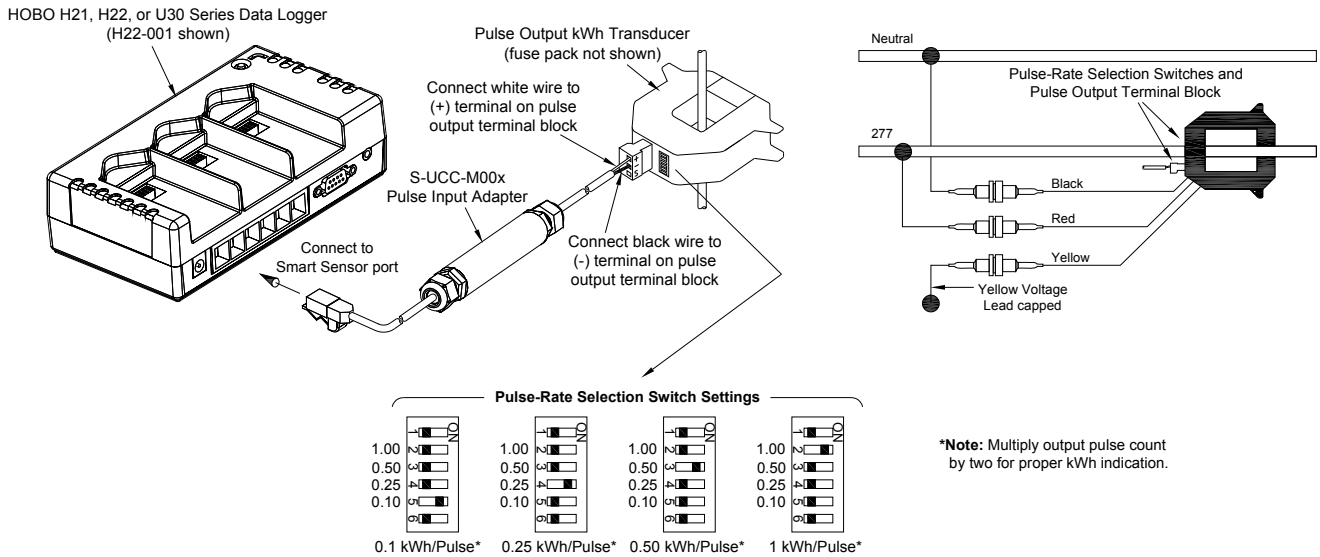

Veris Pulse Output kWh Transducer (Single CT) Connection Instructions

H21, H22, and U30 Typical 208 or 480 VAC Three-Phase Three/Four-Wire Connection

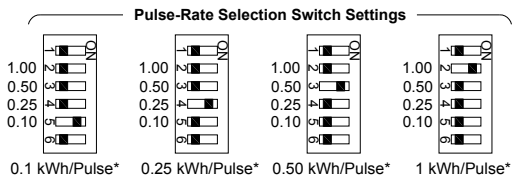
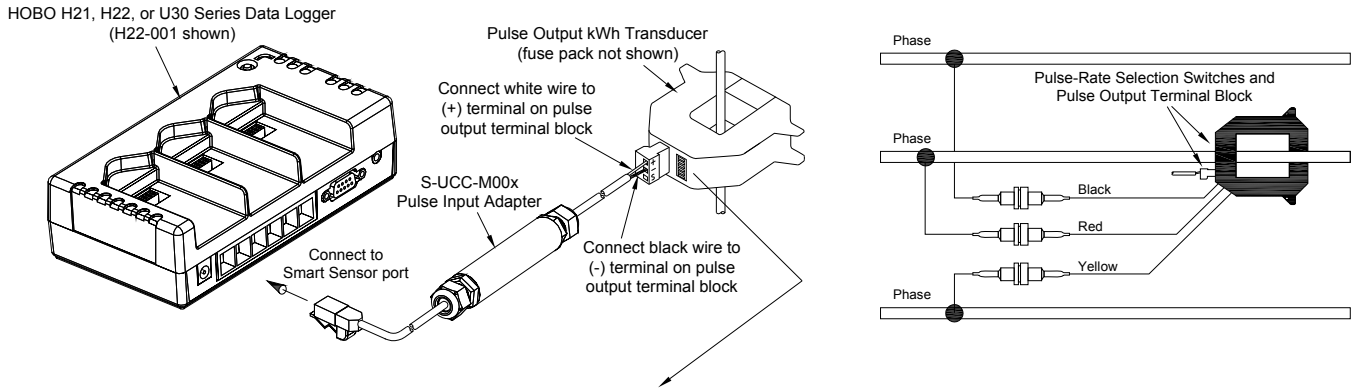

***Note:** When using single CT model (T-VER-8051-300) to monitor a **balanced** three-phase system, multiply output pulse count by three for proper kWh indication.

UX120 and ZW Connection

(also refer to the appropriate CT wiring diagram in the H21/H22/U30 connection section for your particular electrical power configuration)

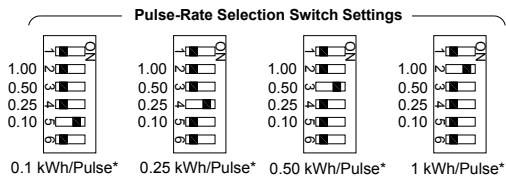
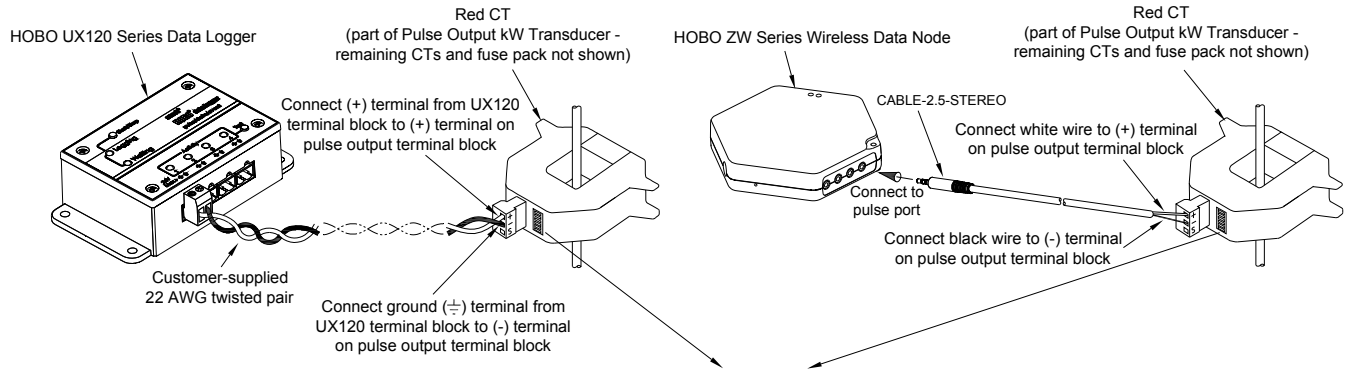

* Refer to asterisked note in the H21/H22/U30 connection section for your particular electrical power configuration