

LUXOR

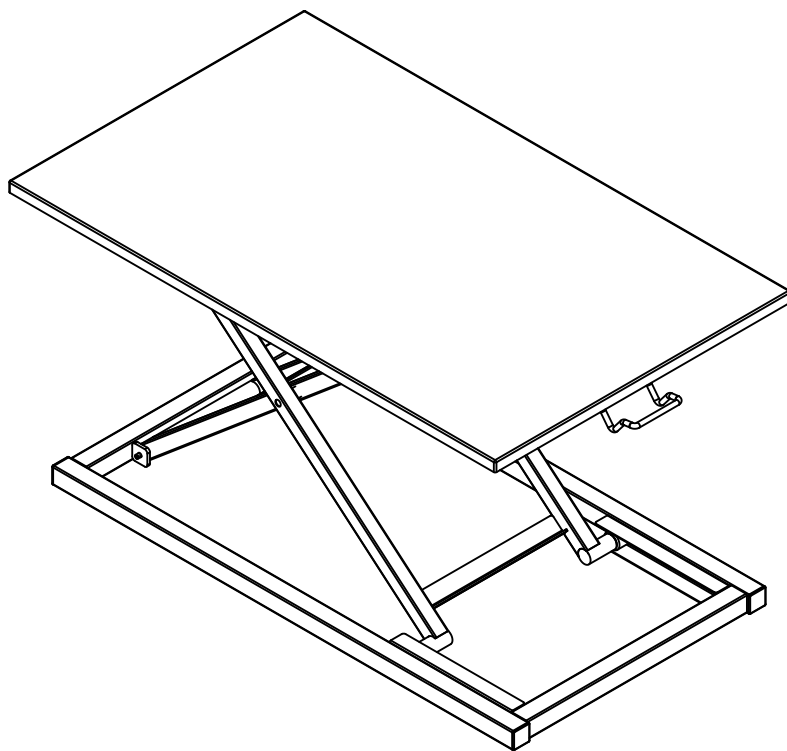

Questions or concerns?
Contact us directly!



1-800-323-4656
Info@LuxorFurn.com

CVTR32

Part List

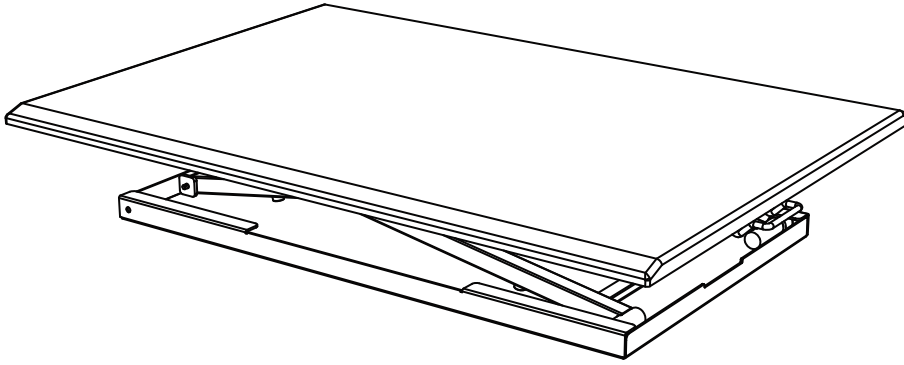

x1

IMPORTANT! - Safety

Confirm the surface that this desk will go onto can support the load of the desk (42 lbs (19KG)) + any equipment that will go onto the desk.

The desk is designed to easily lift and lower 11 lbs (5KG), and MAX Weight Capacity = 35 lbs (16KG).

Two people are required when setting up or moving the desk. The desk must be in tallest position before moving to the intended surface. If the desk is moved in any other position, it may open causing instability. Failure to follow these instructions may result in serious personal injury.

During the initial setup, raise the desk to the tallest setting before putting on equipment. Check the cable lengths, and make sure the cables have slack. Without slack in the cables, equipment may be pulled off of the surface during travel. Failure to follow these instructions may result in equipment damage or personal injury.

Do not have equipment near the edges to prevent equipment from falling off the desk. Failure to follow these instructions may result in equipment damage or personal injury.

Keep cables clear of the support structure. Failure to follow these instructions may result in equipment damage or personal injury.

Raise and lower desk slowly. Raising the desk too quickly may cause equipment on the desk to become unstable. Failure to follow these instructions may result in equipment damage or personal injury.

If moving the desk to a new location, raise the desk to the tallest setting, and remove the items from the desk surface. Failure to follow these instructions may result in equipment damage or personal injury.

This desk raises and lowers with air cylinder assistance. This cylinder is under high pressure. Do not open the cylinder! Do not heat the cylinder! Failure to follow these instructions may result in serious personal injury.

Pinch Point - Keep hands off and away from the support structure. Pinch points are created during operation. Failure to follow these instructions may result in serious personal injury.

Step 1: Read the important safety section of the instructions before proceeding.
Lift up on the handle on the right side of the upper surface to raise the desk to the tallest position.

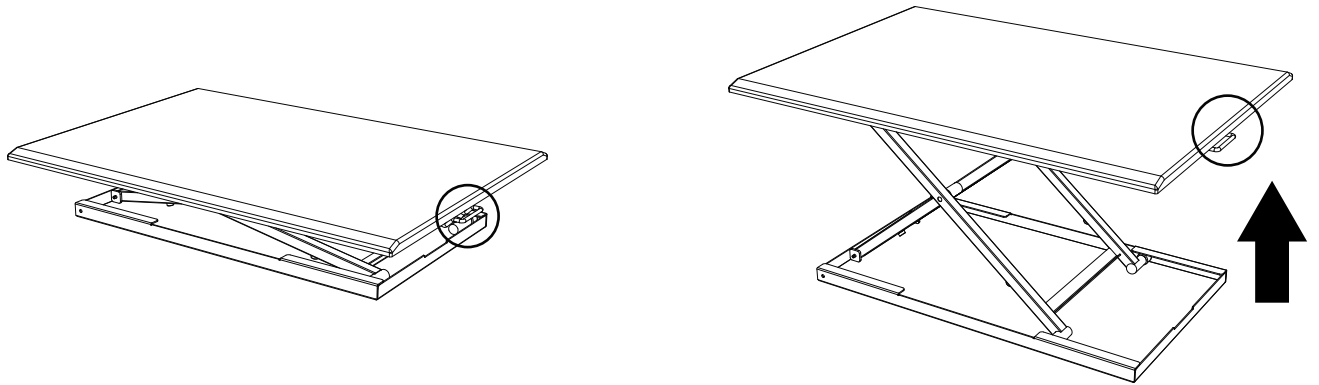

Step 2: With assistance, place the desk onto the intended surface.

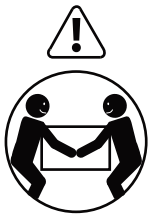

Heavy Lifting:
Assistance
Required

