

ERGOTRON®

User's Guide

Touchboards

Styleview Dual Monitor Accessory

205 Westwood Ave, Long Branch, NJ 07740
Phone: 866-94 BOARDS (26273) / (732)-222-1511
Fax: (732)-222-7088 | E-mail: sales@touchboards.com

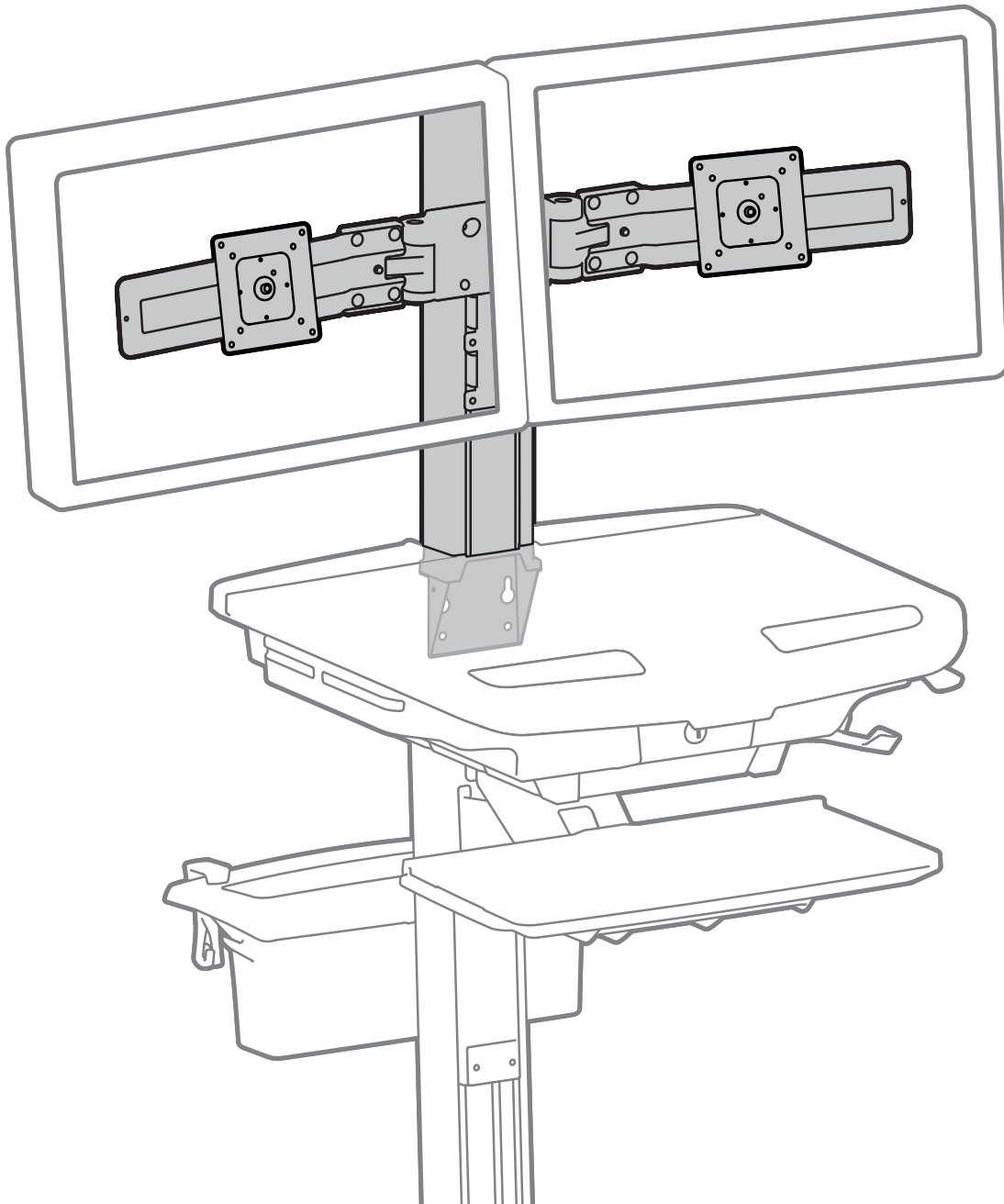

ENGLISH

For the latest User Installation Guide please visit: www.ergotron.com



User's Guide - English
Guía del usuario - Español
Manuel de l'utilisateur - Français
Gebruikersgids - Deutsch
Benutzerhandbuch - Nederlands
Guida per l'utente - Italiano
Användarhandbok - svenska
ユーザーガイド : 日本語
用户指南 : 汉语



Includes
Constant Force™
Technology







www.ergotron.com

USA 1-800-888-8458
Europe +31 (0)33-45 45 600
China 400-120-3051

Hazard Symbols Review





These symbols alert users of a safety condition that demands attention. All users should be able to recognize and understand the significance of the following Safety Hazards if encountered on the product or within the documentation. Children who are not able to recognize and respond appropriately to Safety Alerts should not use this product without adult supervision!

Symbol	Signal Word	Level of Hazard
	NOTE	A NOTE indicates important information that helps you make better use of this product.
	CAUTION	A CAUTION indicates either potential damage to hardware or loss of data and tells you how to avoid the problem.
	WARNING	A WARNING indicates either potential for property damage, personal injury, or death.
	ELECTRICAL	An Electrical indicates an impending electrical hazard which, if not avoided, may result in personal injury, fire and/or death.

Safety



Important! You will need to adjust this product after installation is complete. Make sure all your equipment is properly installed on the product before attempting adjustments. This product should move smoothly and easily through the full range of motion and stay where you set it. If movements are too easy or difficult or if product does not stay in desired positions, follow the adjustment instructions to create smooth and easy movements. Depending on your product and the adjustment, it may take many turns to notice a difference. Any time equipment is added or removed from this product, resulting in a change in the weight of the mounted load, you should repeat these adjustment steps to ensure safe and optimum operation.

-  **Caution: If combined LCD and CPU weight is greater than 27lbs (10.4kg) then the CPU must be mounted to the rear of the cart using a CPU holder accessory (ordered seperately).**
-  **Caution: For use with SV42/44 SLA carts: Monitors must be 12lbs or less each and matching. Do not exceed the maximum height adjustment assembly capacity of 35lbs.**
-  **Caution: To avoid the potential to pinch cables it is important to follow the cable routing instructions in this manual. Failure to follow these instructions may result in equipment damage or personal injury.**
-  **Caution: Lower worksurface before moving cart. Failure to follow these instructions may result in equipment damage or personal injury.**

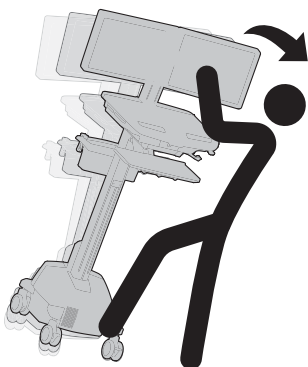

Warning: Not intended for use with SV40, 41, and 42/44 LiFe carts. These configurations create a tipping hazard when the height adjustment assembly and monitor are at maximum height. Failure to heed this warning may result in serious personal injury or property damage!

Features & Specifications

Monitor Weight:

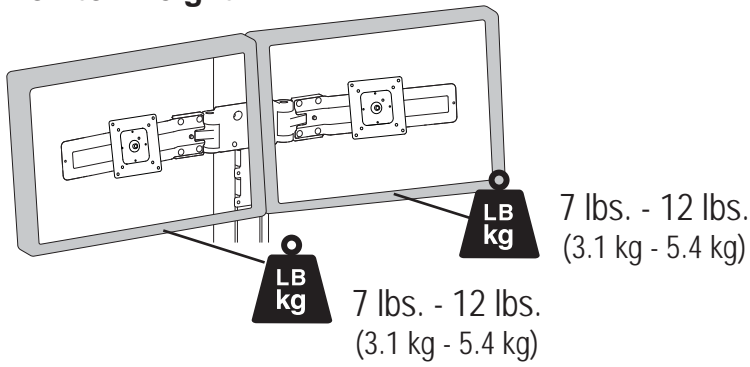

Total weight of monitors when mounted needs to be 14 lbs - 24 lbs (6.2 kg - 10.8 kg)

 CAUTION: DO NOT EXCEED MAXIMUM LISTED WEIGHT CAPACITY. SERIOUS INJURY OR PROPERTY DAMAGE MAY OCCUR!

Maximum Monitor Width:

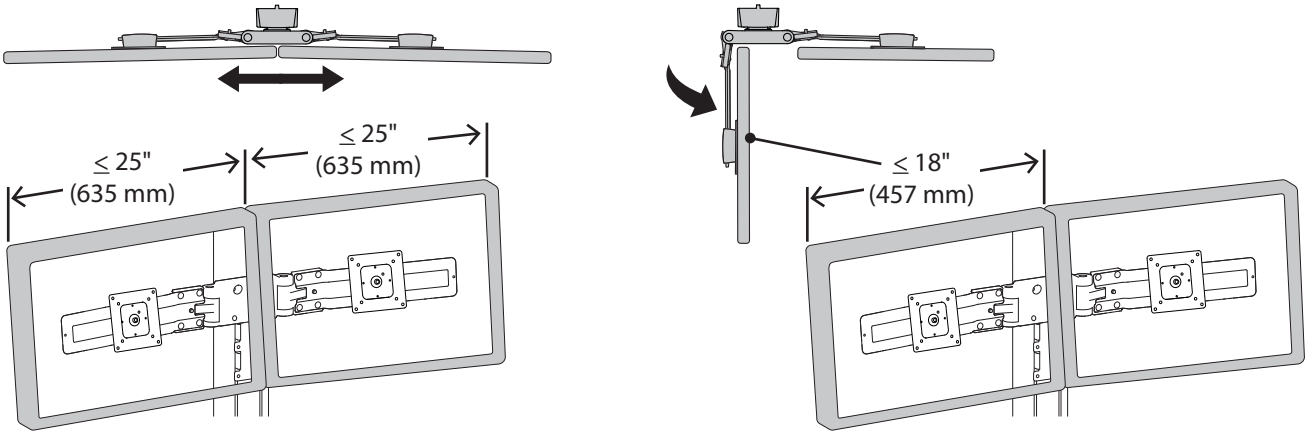

Range of Motion:

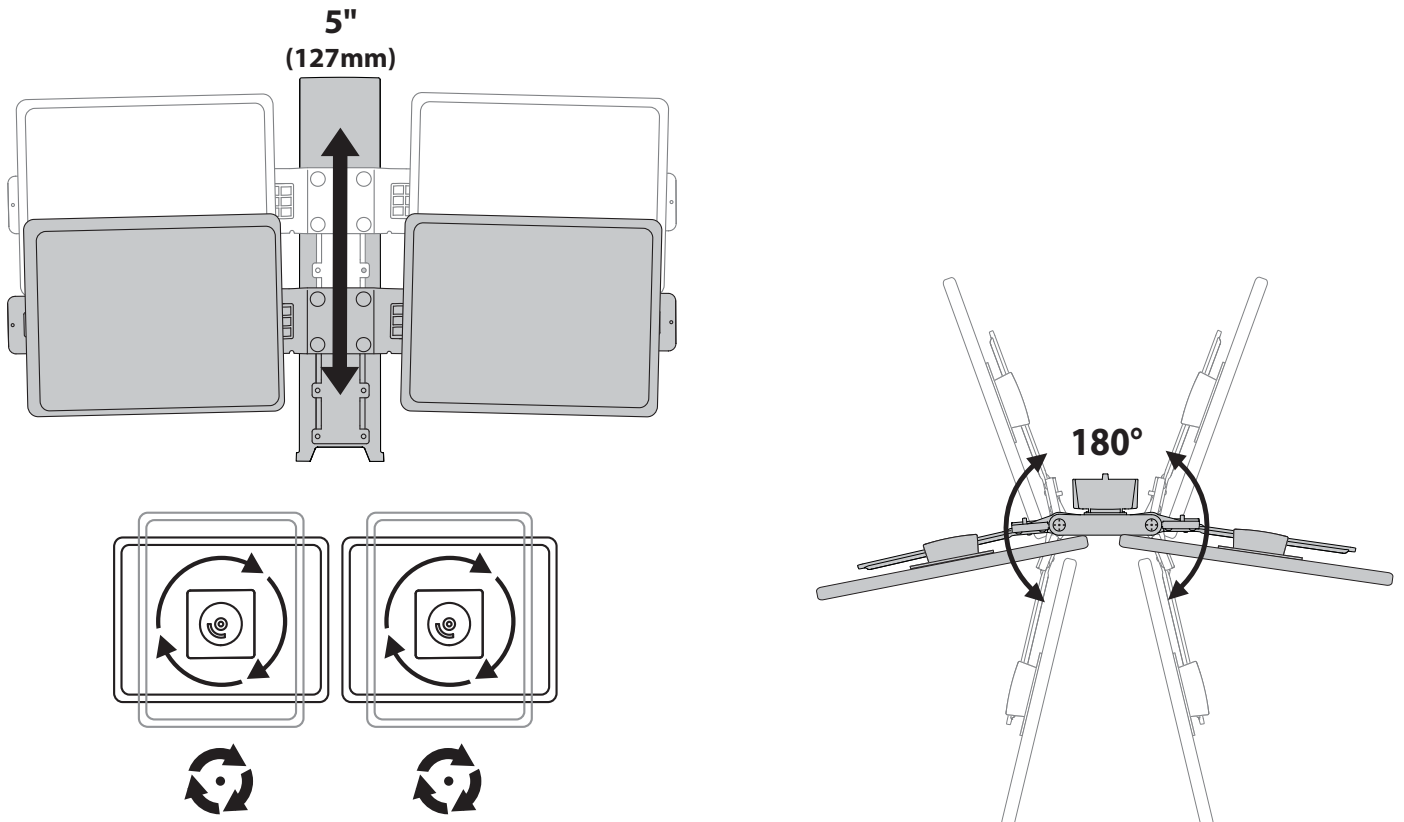

Components



	A	B	C
1	1x	1x	
2		2x	2x
3	8x M4 x 10mm	2x M4 x 10mm	4x M6 x 18mm
4	8x M4 x 10mm	2x M4 x 8mm	2x M4 x 5mm
5	4x 4x M3 x 6mm	2x	8x
6	1x		1x 4mm

ENGLISH

Tools Needed

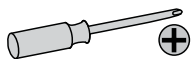
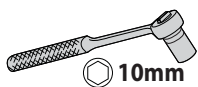

1

Remove Arm or LCD Pivot

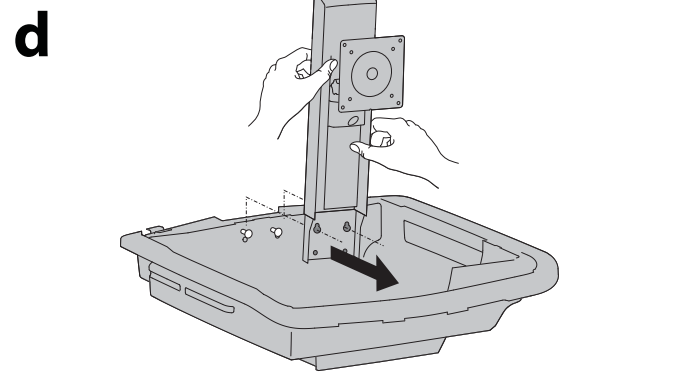
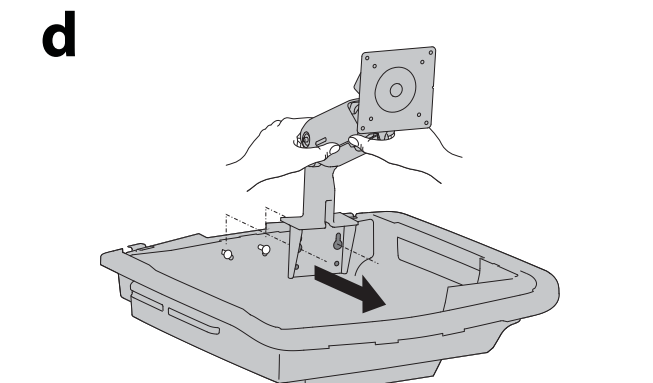
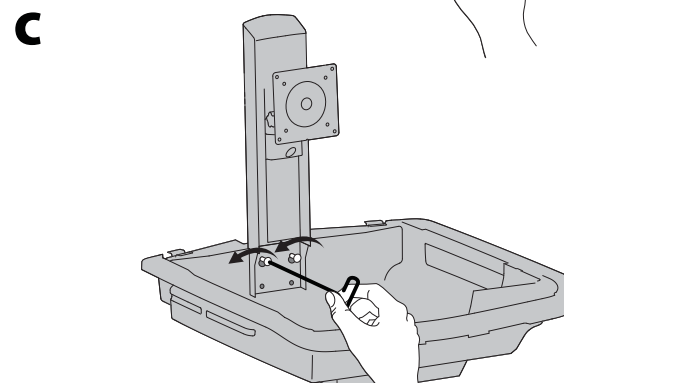
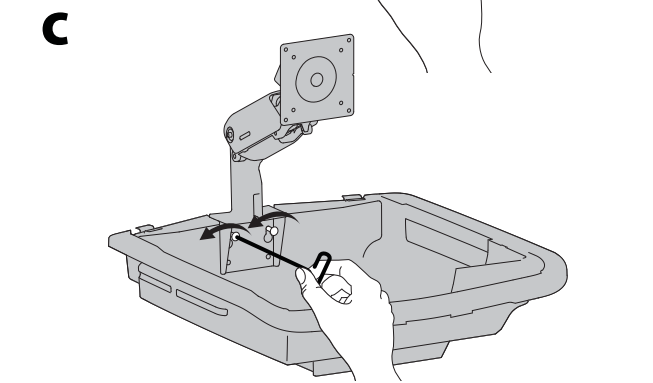
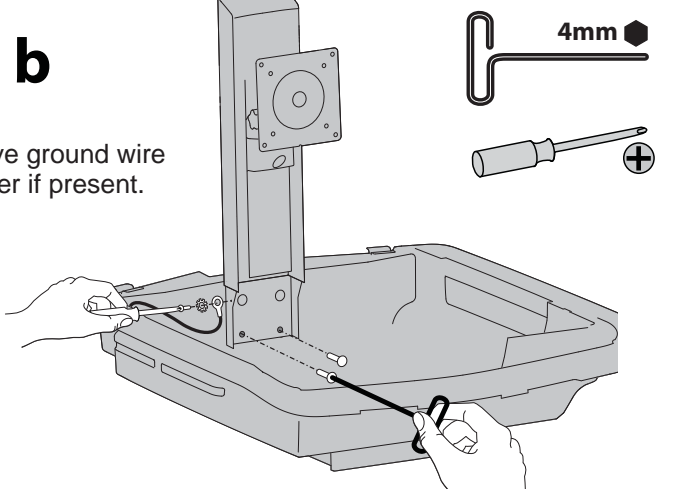
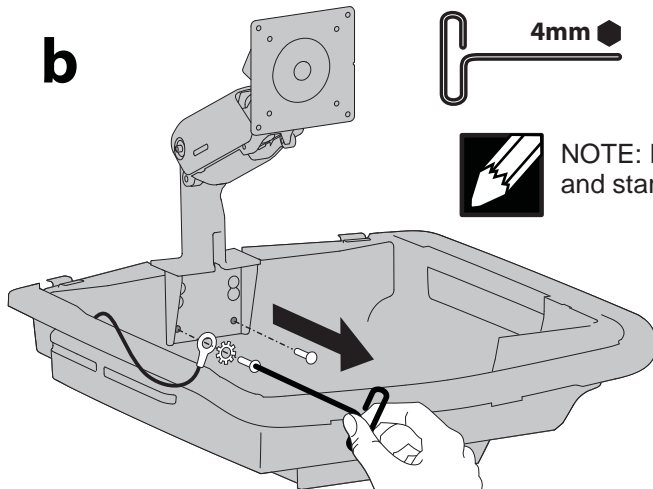
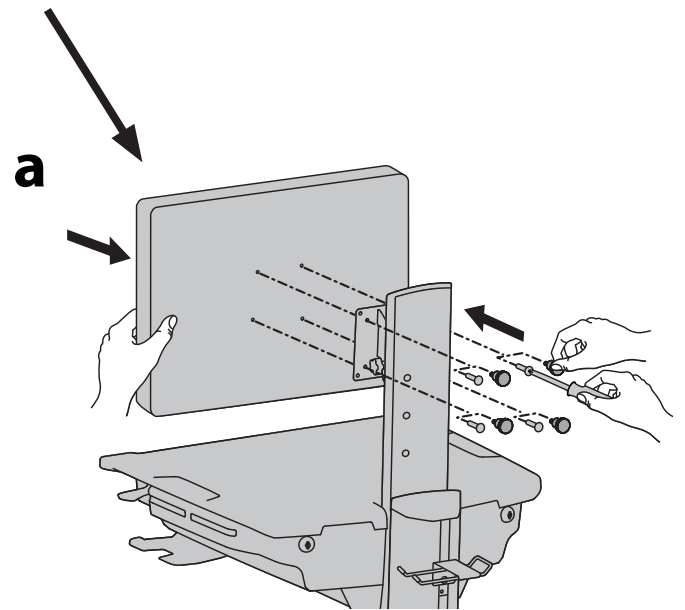
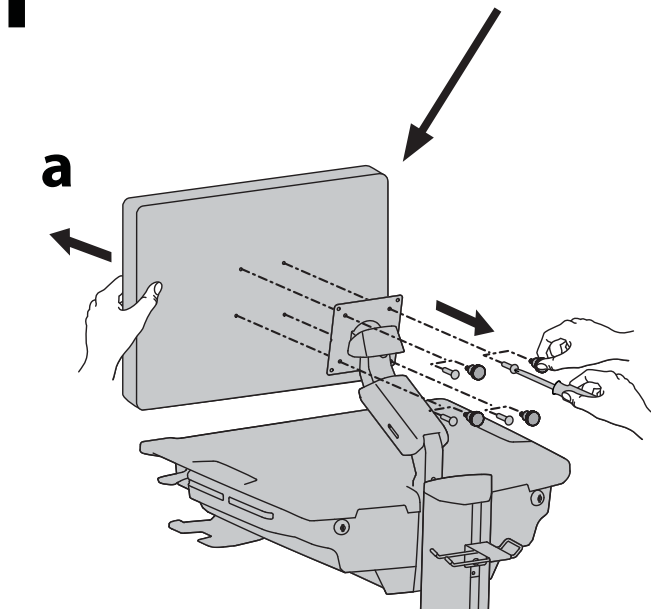

2 Attach Lift

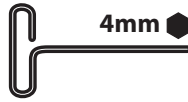

a

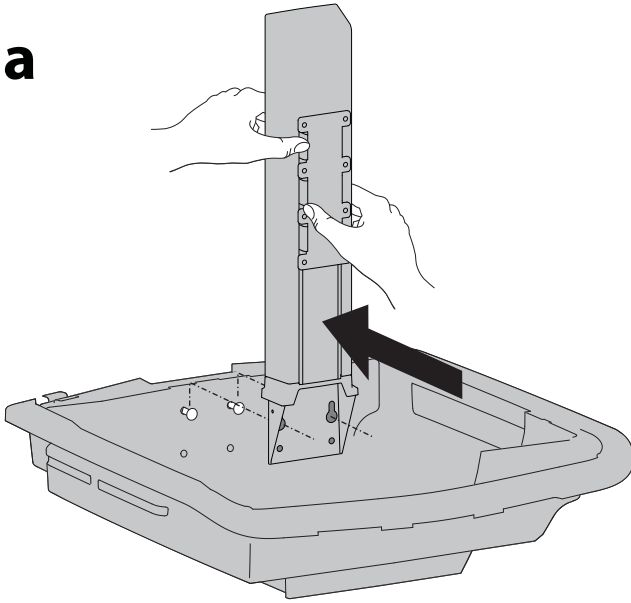

b



NOTE: If you removed a ground wire and star washer, reattach as shown.

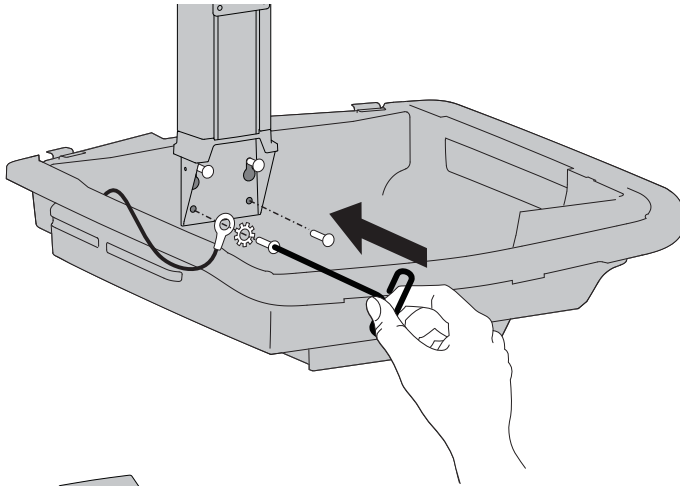

NOTE: Your Styleview cart may have an alternate ground wire connection point. Both points will provide a viable ground path connection.

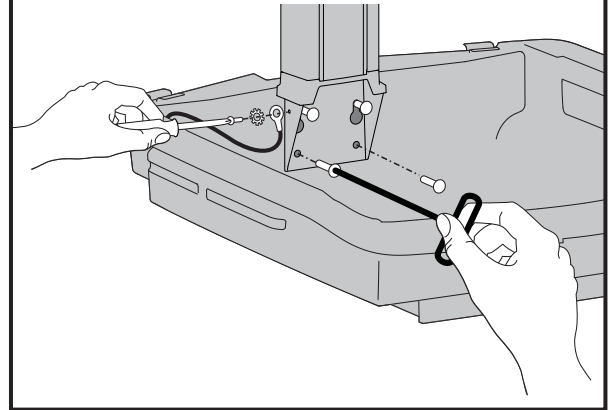

c

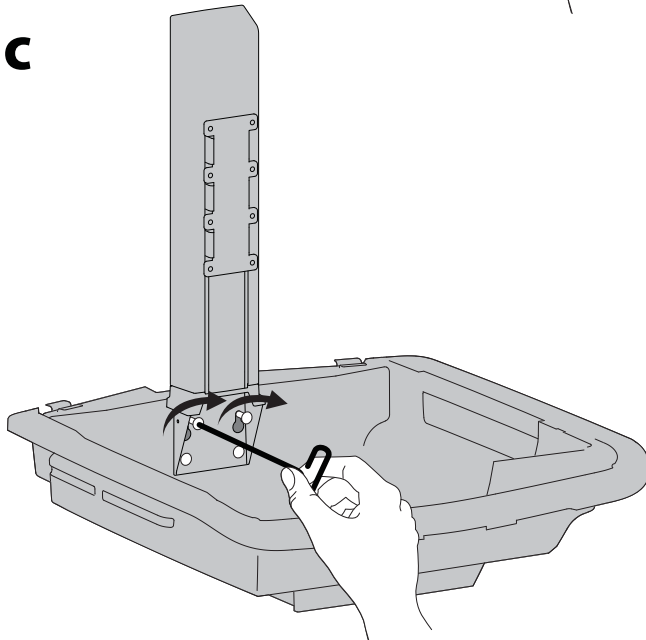

Touchboards

205 Westwood Ave, Long Branch, NJ 07740
Phone: 866-94 BOARDS (26273) / (732)-222-1511
Fax: (732)-222-7088 | E-mail: sales@touchboards.com

3 Attach Crossbar to Lift

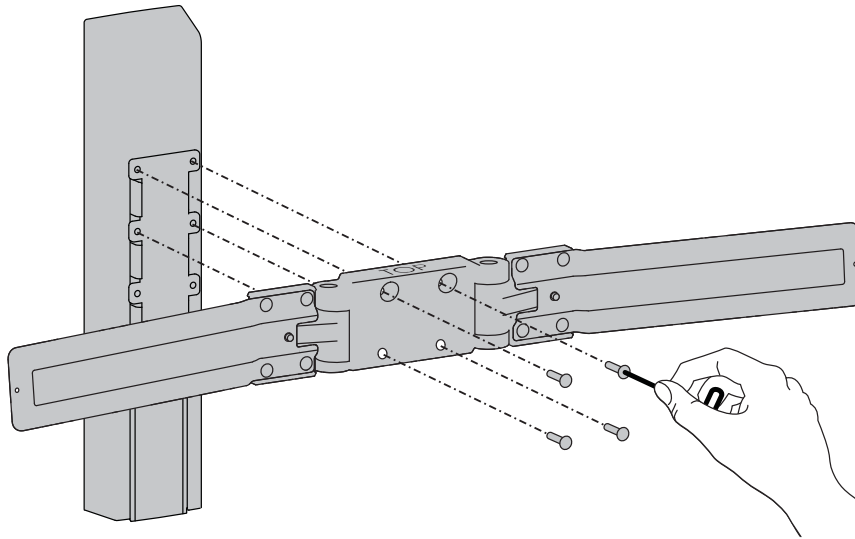
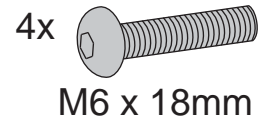
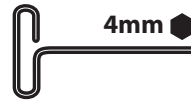

4 Attach Monitors to Pivot

OPTIONAL: Insert stop screw to lock portrait/landscape monitor rotation.

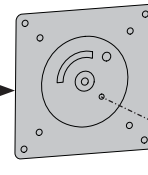
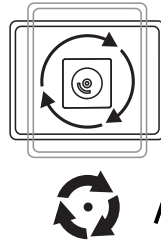

1x
M4 x 8mm

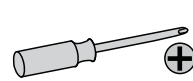
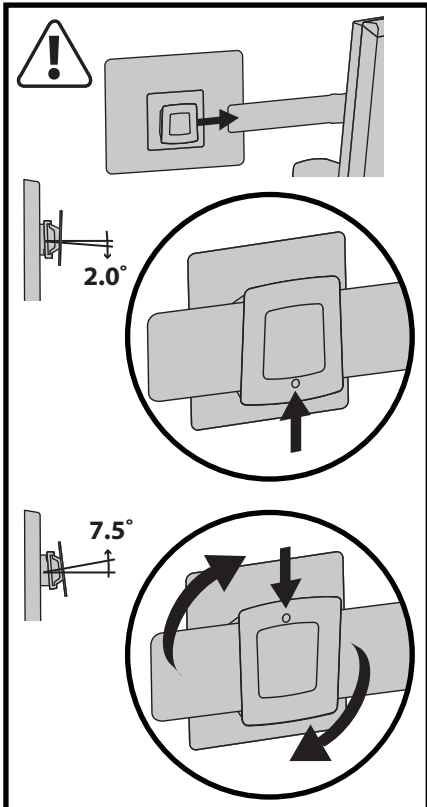

4x
M4 x 10mm

4x
M4 x 10mm

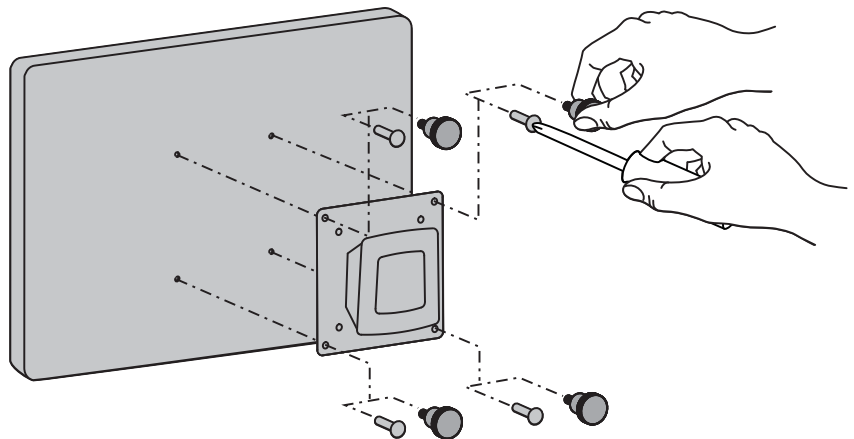

5 Slide Pivots onto Crossbar

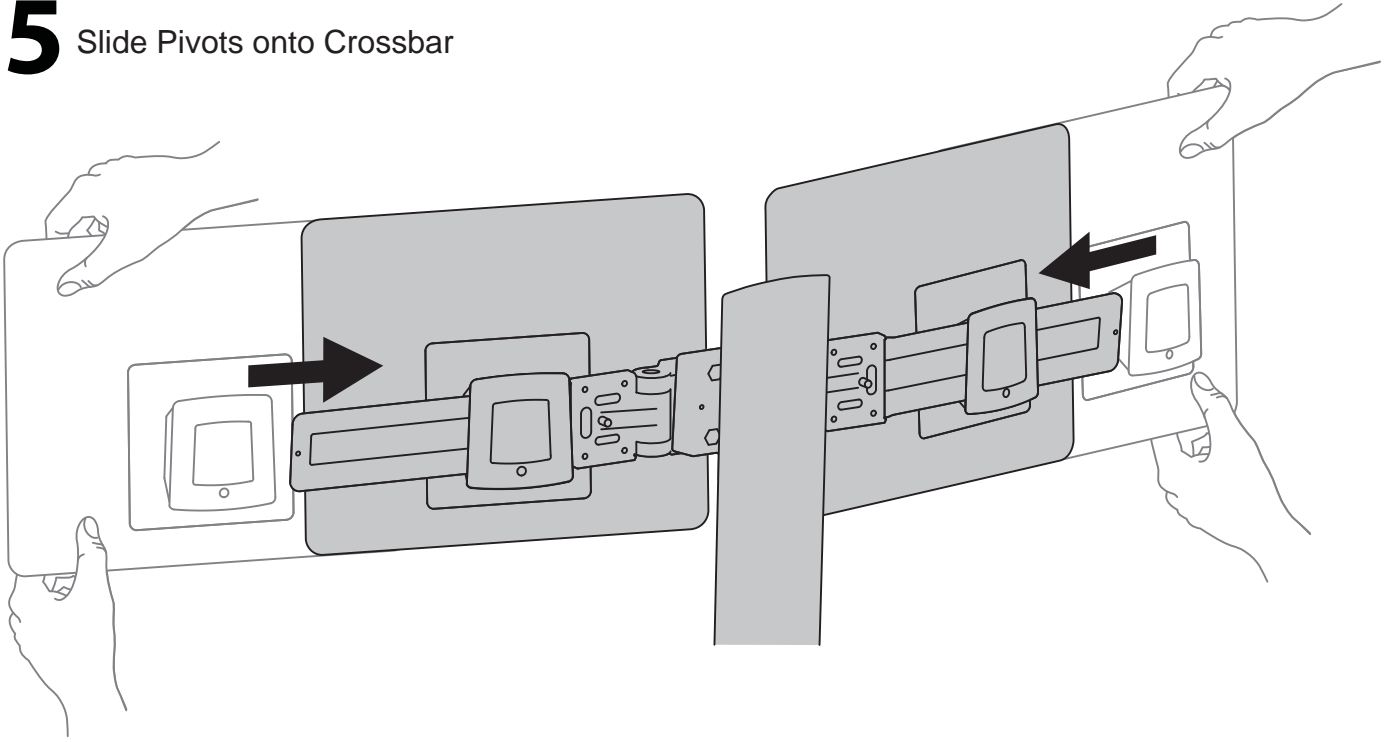

6 Secure Pivots to Crossbar

ENGLISH

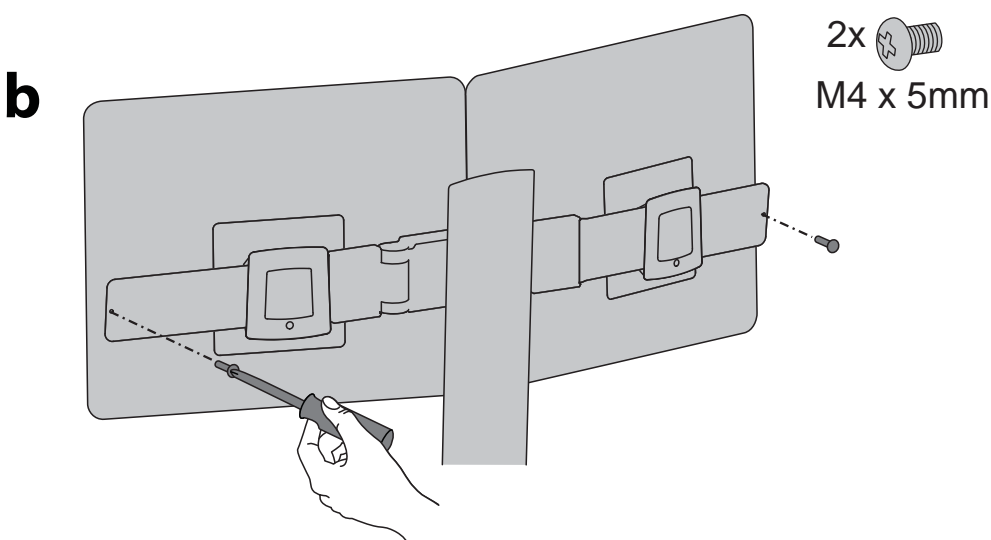
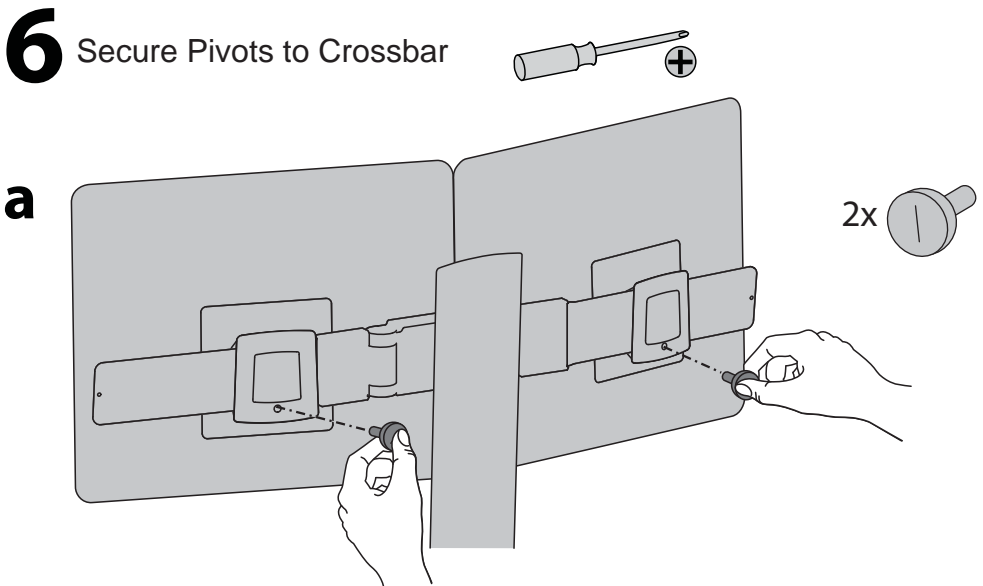

7 Attach Grounding Cables

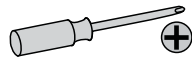

4x M3 x 6mm

2x

4x

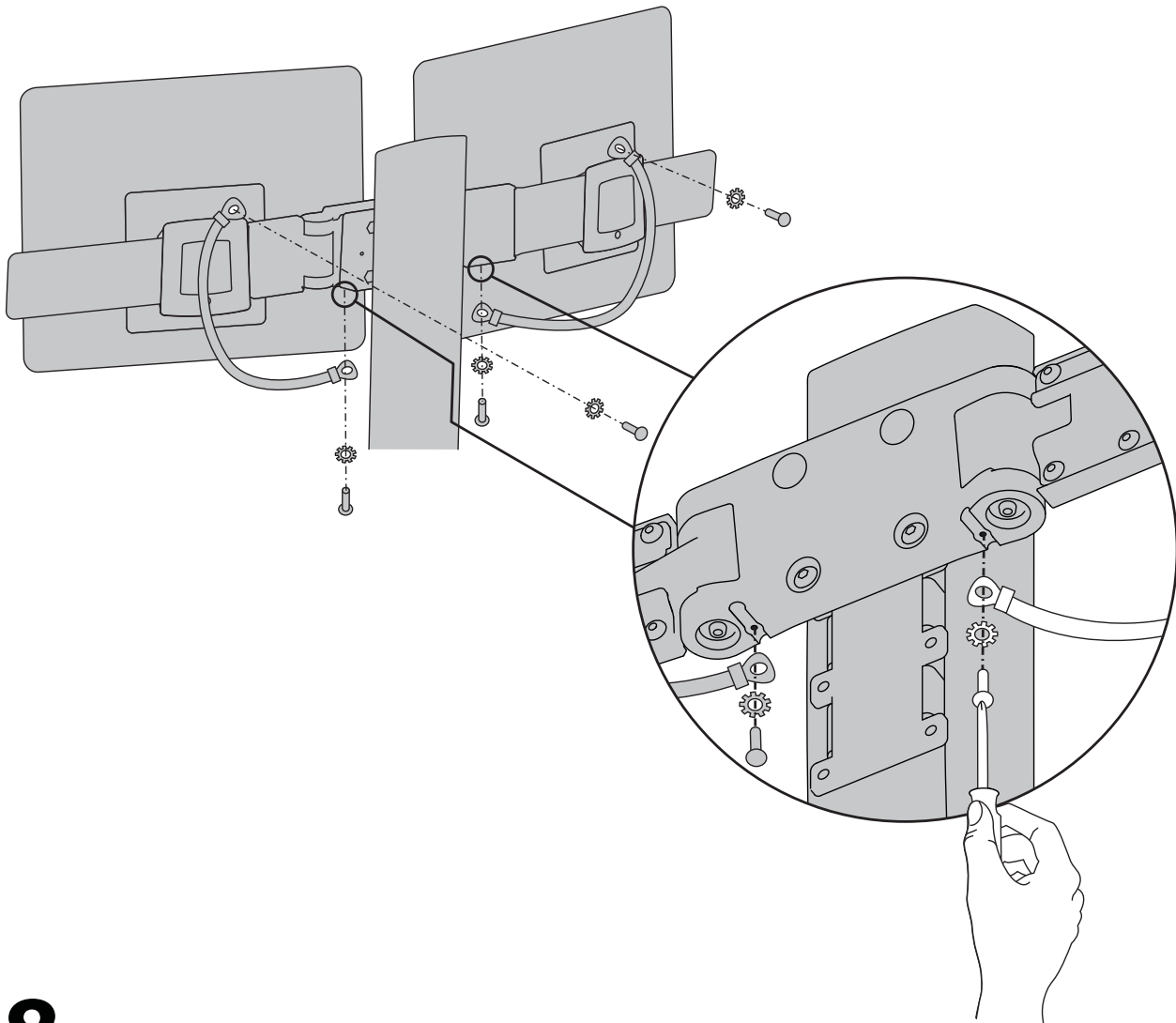

8 Secure Monitor Cables with Cable Ties

2x

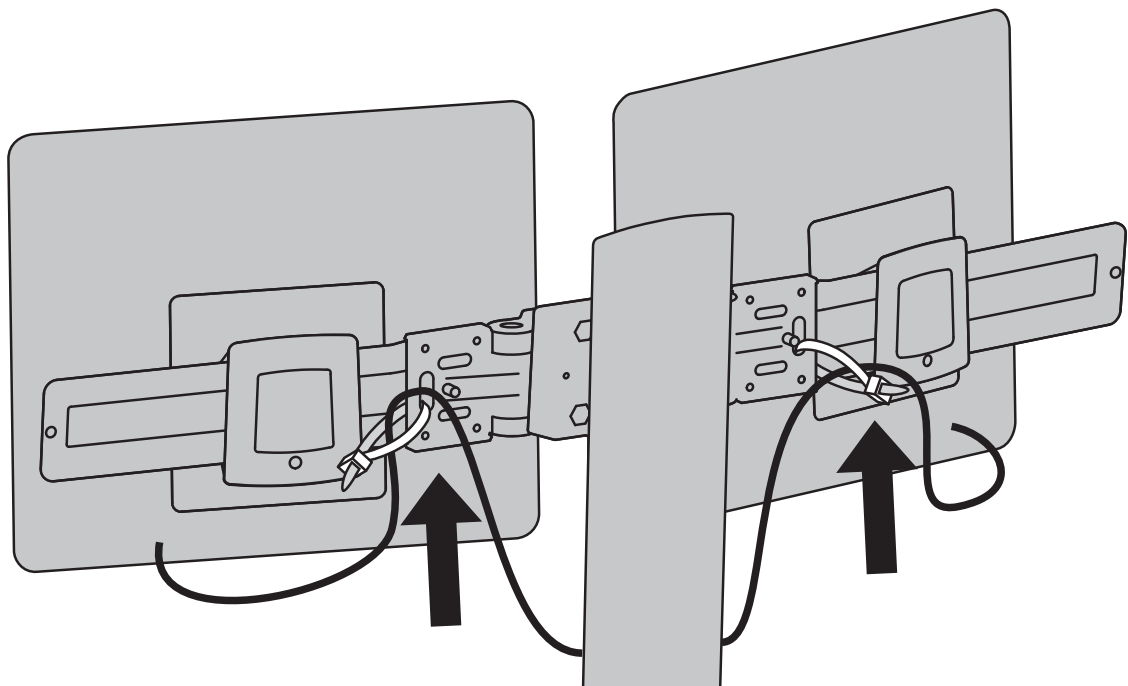
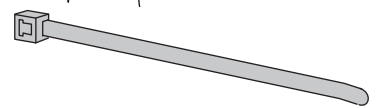

9 Adjustment Step

Important! You will need to adjust this product after installation is complete. Make sure all your equipment is properly installed on the product before attempting adjustments. This product should move smoothly and easily through the full range of motion and stay where you set it. If movements are too easy or difficult or if product does not stay in desired positions, follow the adjustment instructions to create smooth and easy movements. Depending on your product and the adjustment, it may take many turns to notice a difference. Any time equipment is added or removed from this product, resulting in a change in the weight of the mounted load, you should repeat these adjustment steps to ensure safe and optimum operation.

a Cart Lift, up and down.

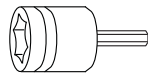
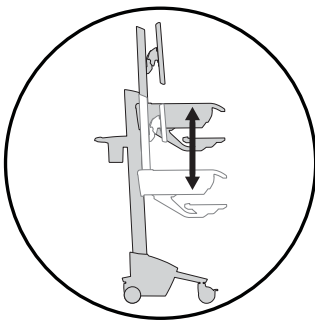

14mm (9/16")

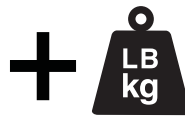

Increase Lift Strength

If the mounted weight is too heavy or this product does not stay up when raised, then you'll need to increase Lift Strength:



Decrease Lift Strength

If the mounted weight is too light or this product does not stay down when lowered, then you'll need to decrease Lift Strength:

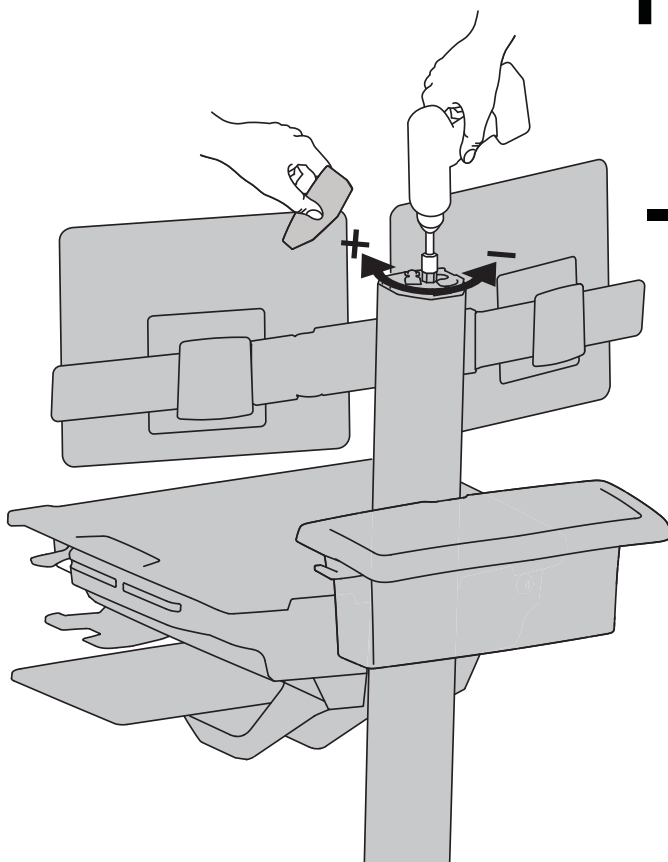

b Monitor Lift, up and down.

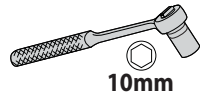
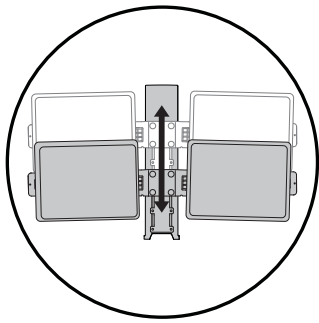

10mm



Increase Lift Strength

If the mounted weight is too heavy or this product does not stay up when raised, then you'll need to increase Lift Strength:



Decrease Lift Strength

If the mounted weight is too light or this product does not stay down when lowered, then you'll need to decrease Lift Strength:

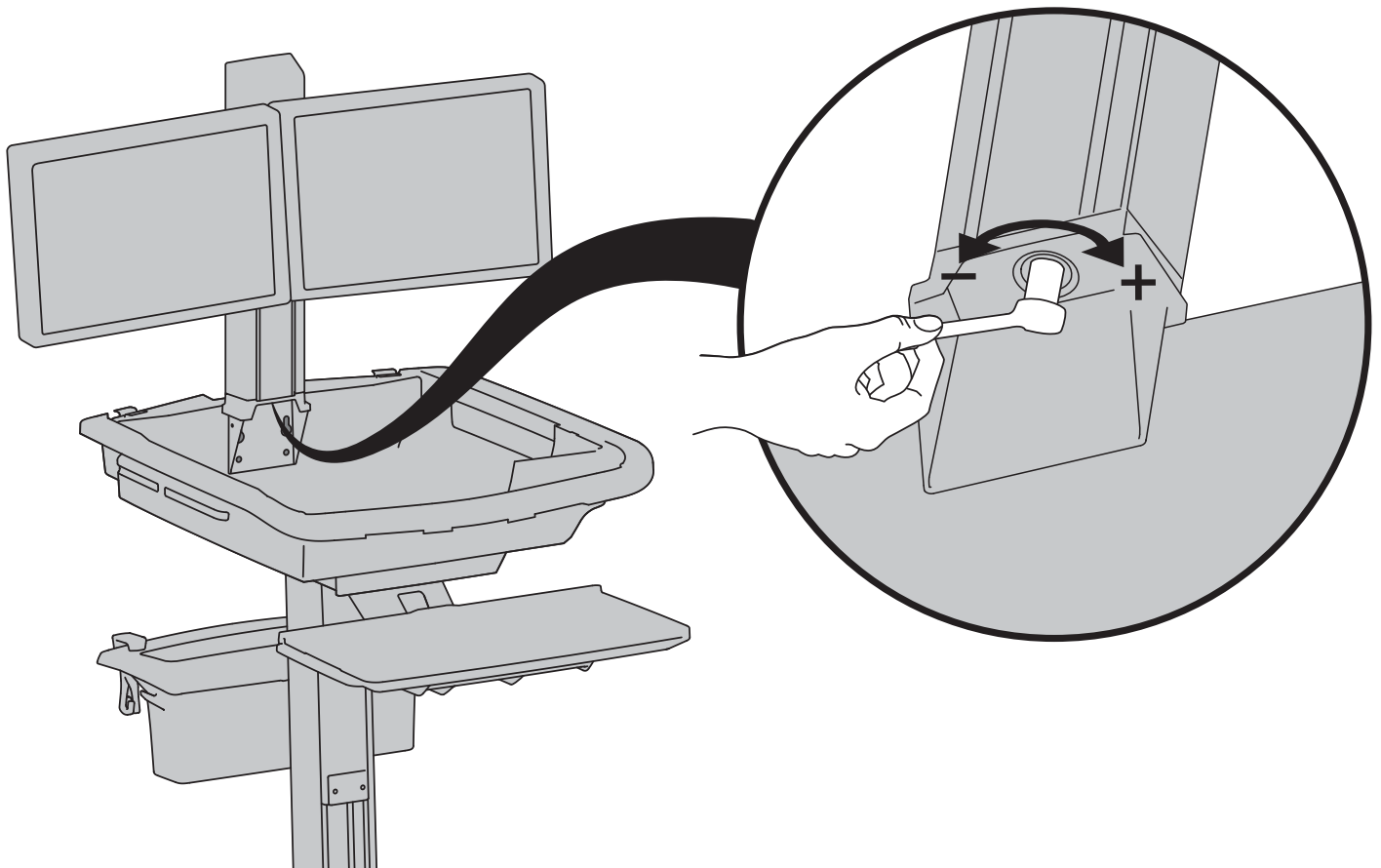

Set Your Workstation to Work For YOU!

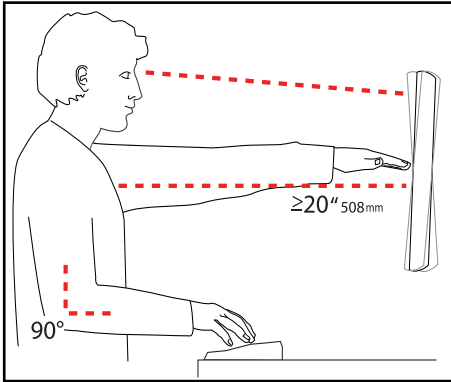

Learn more about ergonomic computer use at:
www.computingcomfort.org

- Height Position top of screen slightly below eye level.
Position keyboard at about elbow height with wrists flat.
- Distance Position screen an arm's length from face—at least 20" (508mm).
Position keyboard close enough to create a 90° angle in elbow.
- Angle Tilt the keyboard back 10° so that your wrists remain flat.

- To Reduce Fatigue
- Breathe - Breathe deeply through your nose.
 - Blink - Blink often to avoid dry eyes.
 - Break • 2 to 3 minutes every 20 minutes
 - 15 to 20 minutes every 2 hours.

For Warranty visit: www.ergotron.com/warranty

For Service visit: www.ergotron.com

For local customer care phone numbers visit: <http://contact.ergotron.com>



NOTE: When contacting customer service, reference the serial number.

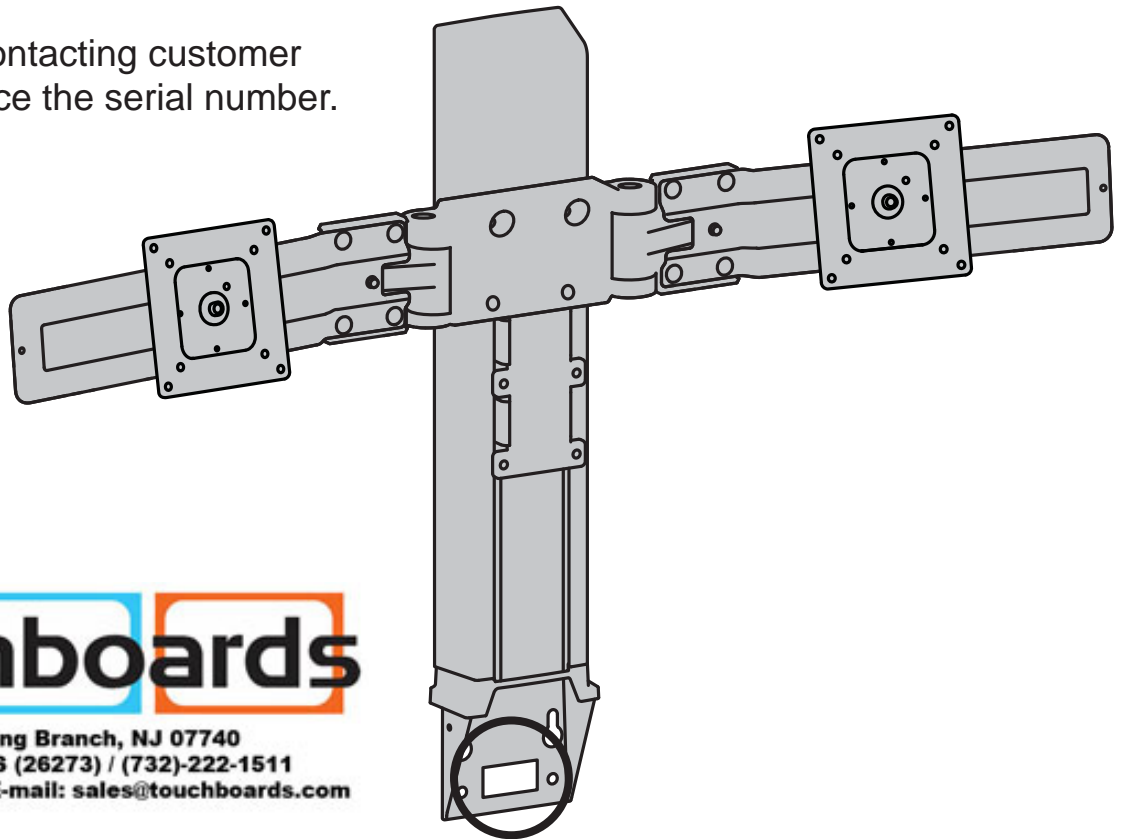

Touchboards

205 Westwood Ave, Long Branch, NJ 07740
Phone: 866-94 BOARDS (26273) / (732)-222-1511
Fax: (732)-222-7088 | E-mail: sales@touchboards.com

Americas Sales and Corporate Headquarters

1181 Trapp Rd.
St. Paul, MN USA
(800) 888-8458
+1-651-681-7600
www.ergotron.com
sales@ergotron.com

EMEA Sales

Amersfoort, The Netherlands
+31 33 45 45 600
www.ergotron.com
info.eu@ergotron.com

APAC Sales

Tokyo, Japan
www.ergotron.com
apaccustomerservice@ergotron.com

Worldwide OEM Sales

www.ergotron.com
info.oem@ergotron.com

ERGOTRON®

While Ergotron, Inc. makes every effort to provide accurate and complete information on the installation and use of its products, it will not be held liable for any editorial errors or omissions (including those made in the process of translation from English to another language), or for incidental, special or consequential damages of any nature resulting from furnishing this instruction and performance of equipment in connection with this instruction. Ergotron, Inc. reserves the right to make changes in the product design and/or product documentation without notification to its users. For the most current product information, or to know if this document is available in languages other than those herein, please contact Ergotron. No part of this publication may be reproduced, stored in a retrieval system, or transmitted in any form or by any means, electronic, mechanical, photocopying, recording or otherwise without the prior written consent of Ergotron, Inc., 1181 Trapp Road, Eagan, Minnesota, 55121, USA. Patents Pending and Patented U.S. & Foreign. Ergotron is a registered trademark of Ergotron, Inc.

© 2016 Ergotron, Inc. All rights reserved.