

Zip40 Charging Cart

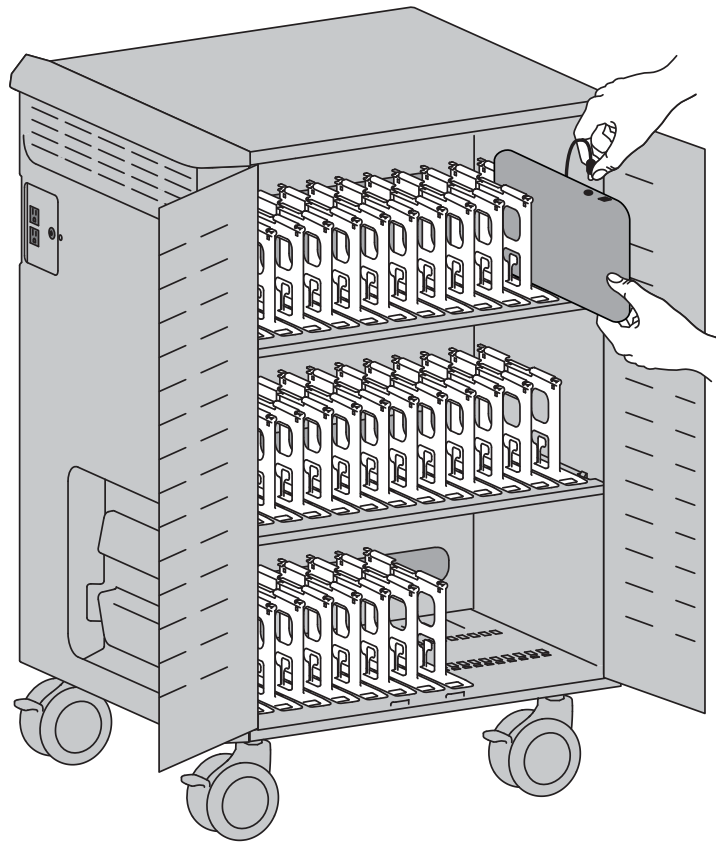

Components

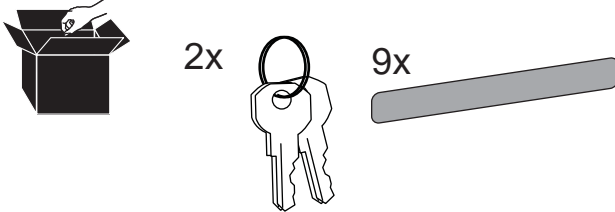

Tools Needed

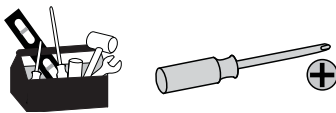

For the latest User Installation Guide please visit: www.ergotron.com



- User's Guide - English
- Guía del usuario - Español
- Manuel de l'utilisateur - Français
- Gebbruikersgids - Deutsch
- Benutzerhandbuch - Nederlands
- Guida per l'utente - Italiano
- Användarhandbok - svenska
- ユーザーガイド : 日本語
- 用户指南 : 汉语







www.ergotron.com

USA 1-800-888-8458
 Europe +31 (0)33-45 45 600
 China 400-120-3051

Hazard Symbols Review

These symbols alert users of a safety condition that demands attention. All users should be able to recognize and understand the significance of the following Safety Hazards if encountered on the product or within the documentation. Children who are not able to recognize and respond appropriately to Safety Alerts should not use this product without adult supervision!

Symbol	Signal Word	Level of Hazard
	NOTE	A NOTE indicates important information that helps you make better use of this product.
	CAUTION	A CAUTION indicates either potential damage to hardware or loss of data and tells you how to avoid the problem.
	WARNING	A WARNING indicates either potential for property damage, personal injury, or death.
	ELECTRICAL	An Electrical indicates an impending electrical hazard which, if not avoided, may result in personal injury, fire and/or death.

Safety

 **Warning: Unplug power cable from outlet and make sure power button is turned off before removing side cover. Removing side cover with power on may cause equipment damage and/or serious personal injury.**

ENGLISH

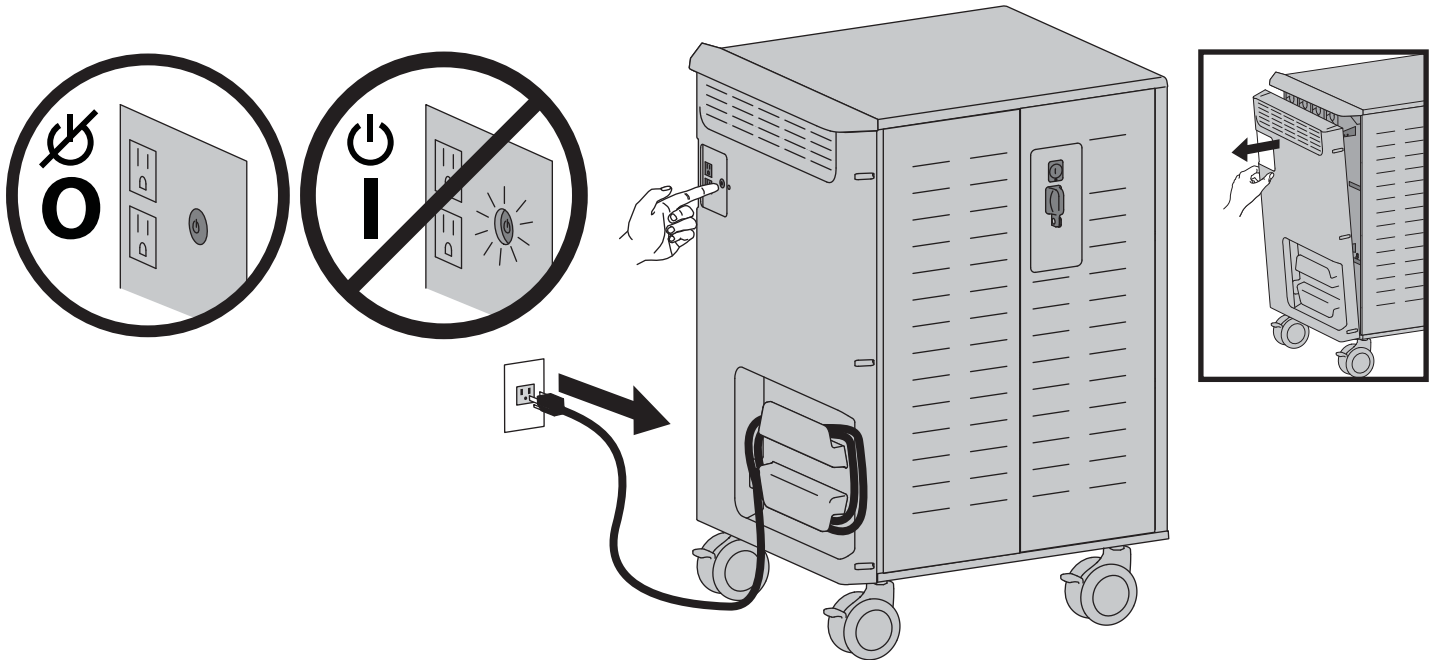

WARNING
MOVING PARTS CAN CRUSH AND CUT
 Unplug power cord.
 DO NOT place hands on or near fans.
 Placing hands on or near fans may cause equipment damage and/or serious personal injury.



828-196

 **WARNING: MOVING PARTS CAN CRUSH AND CUT. Unplug power cord. DO NOT place hands on or near fans. Placing hands on or near fans may cause equipment damage and/or serious personal injury.**

Features & Specifications

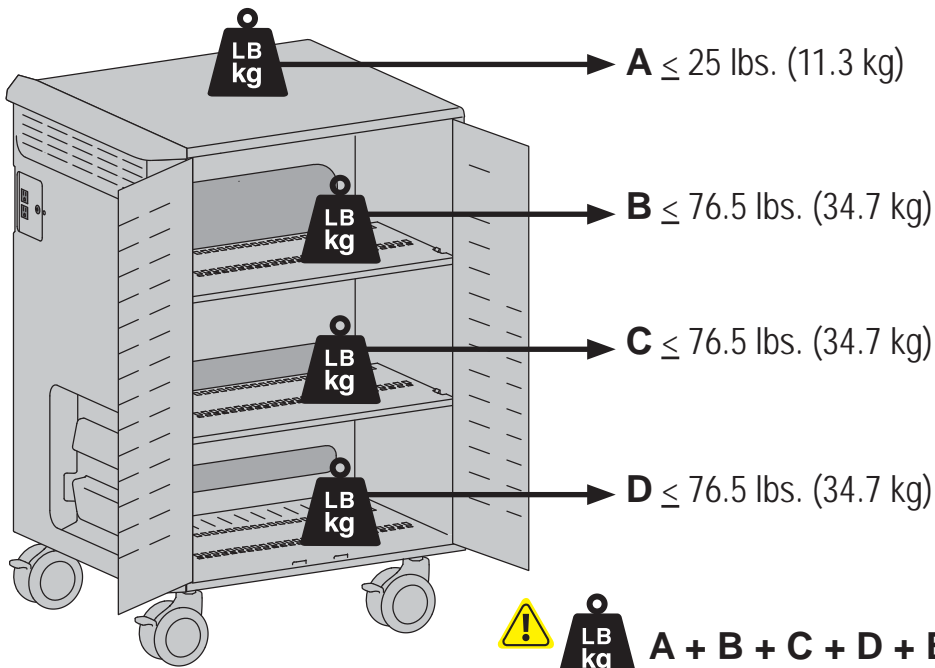
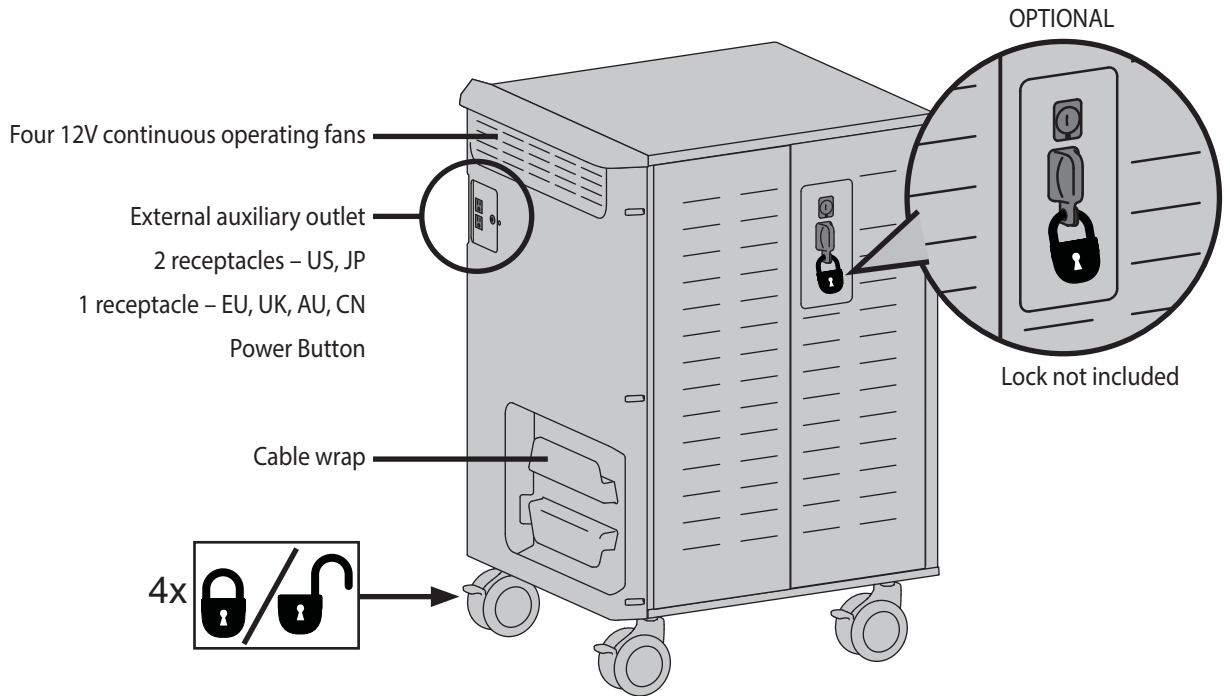

A + B + C + D + E ≤ 255 lbs. (116 kg)

CAUTION: DO NOT EXCEED MAXIMUM LISTED WEIGHT CAPACITY. SERIOUS INJURY OR PROPERTY DAMAGE MAY OCCUR!

1 Open doors.

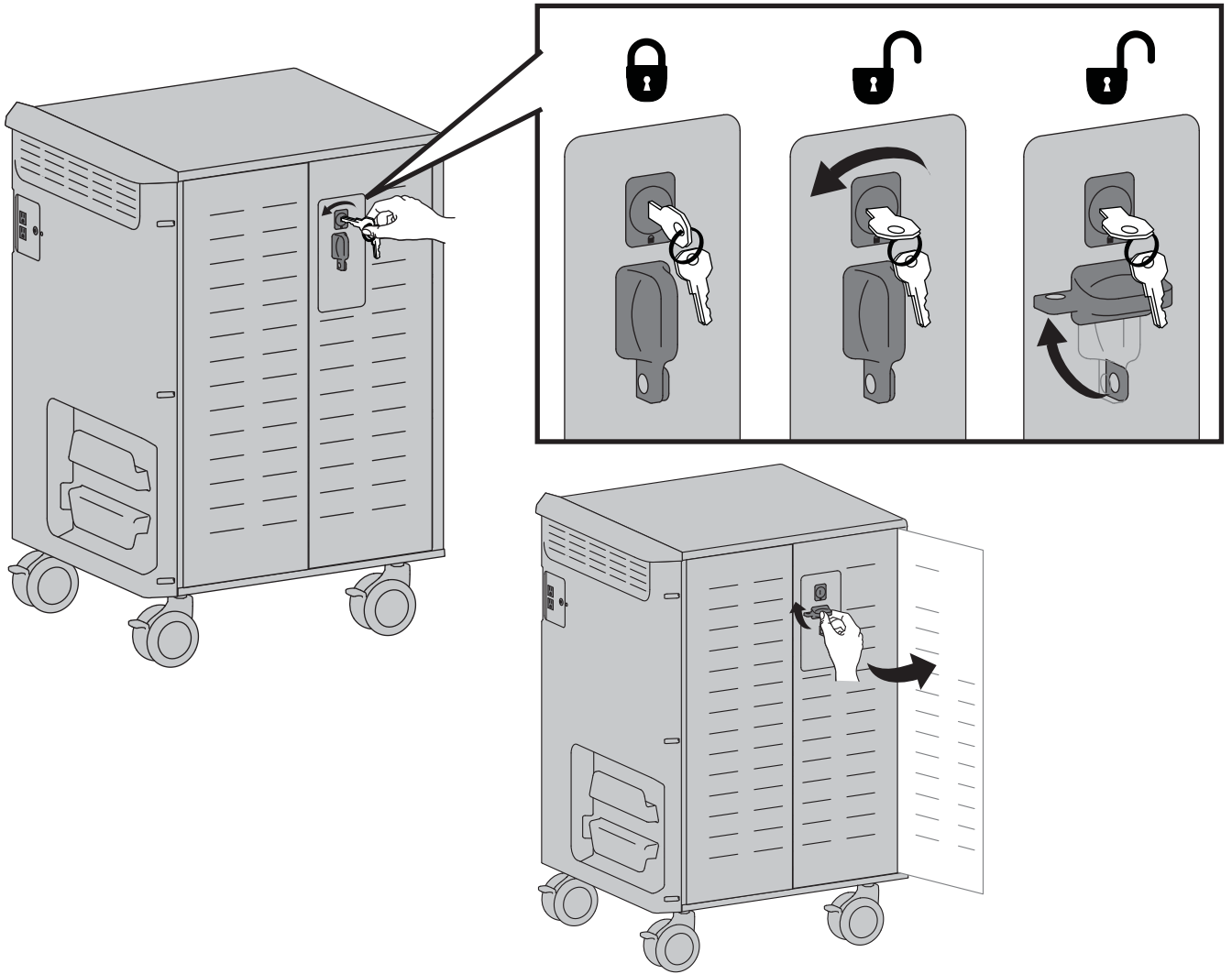

2 Choose configuration for number of devices.

40x Cart is already configured for this, please skip to page 9.

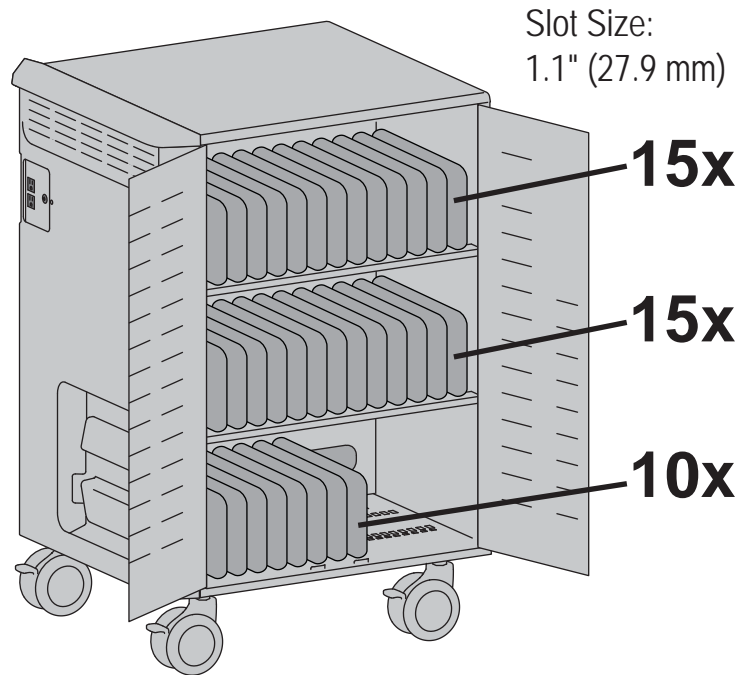

30x Dividers and Ethernet cables will need to be reconfigured for this set up, please see instructions on pages 6-8.

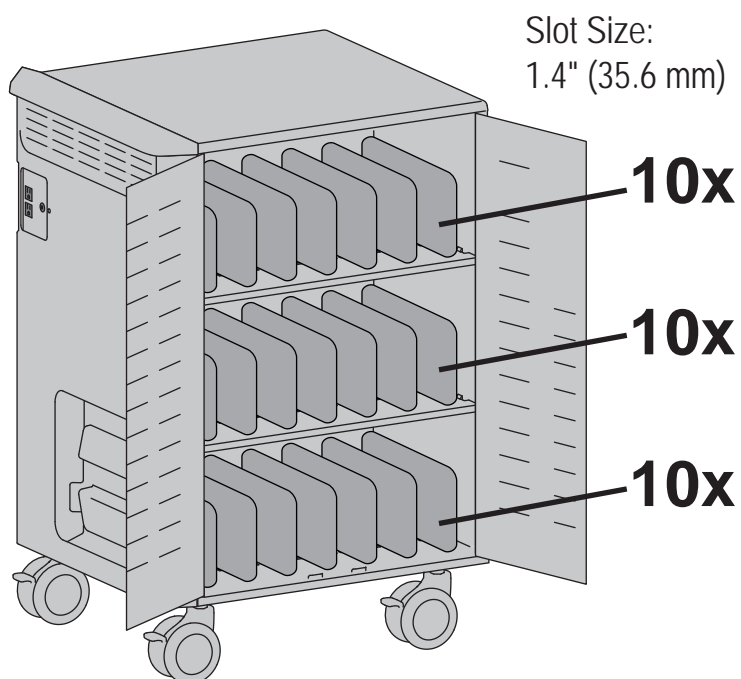

30x

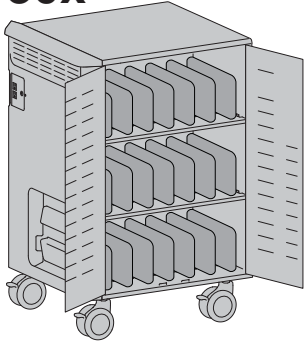

- a** To configure for 30 devices, remove dividers.
- Pull lever towards you.
 - With lever pulled, slide divider towards you.
 - Lift up and off.

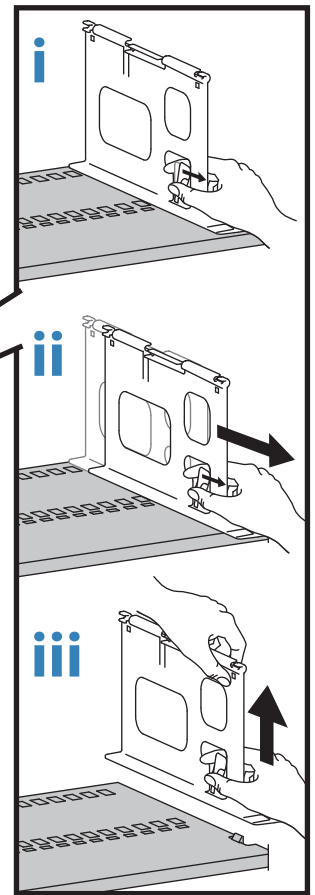
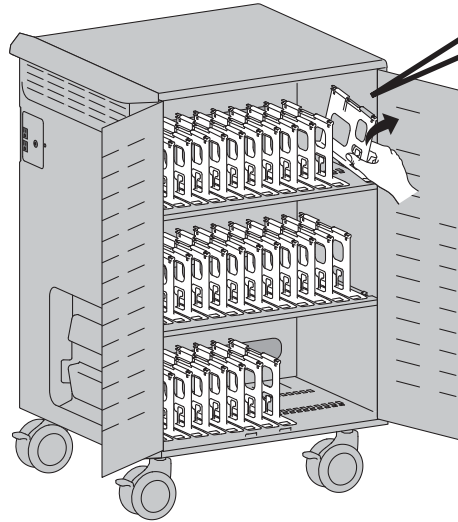

- b** To configure for 30 devices, reattach dividers, 10 per shelf.
- Insert tabs on bottom of divider into designated holes on shelf.
 - Slide divider away from you to lock into place.

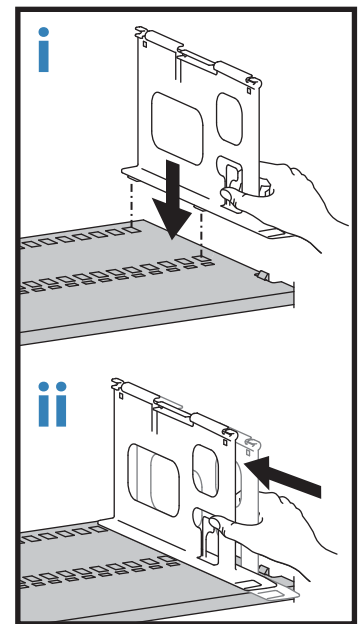
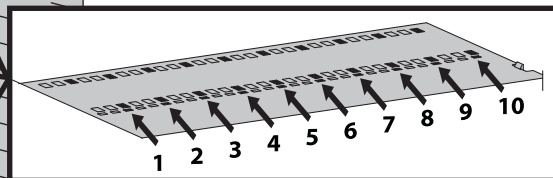
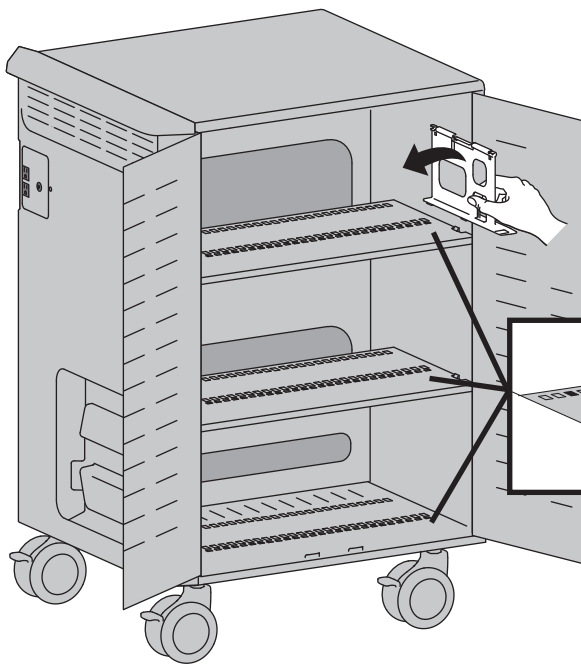

40x

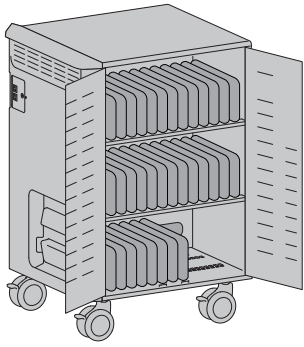

30x

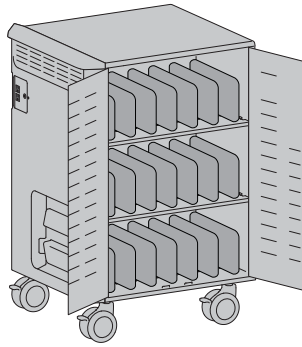

3 Attach spacers if your devices are $\leq 9"$ (229 mm).

40x

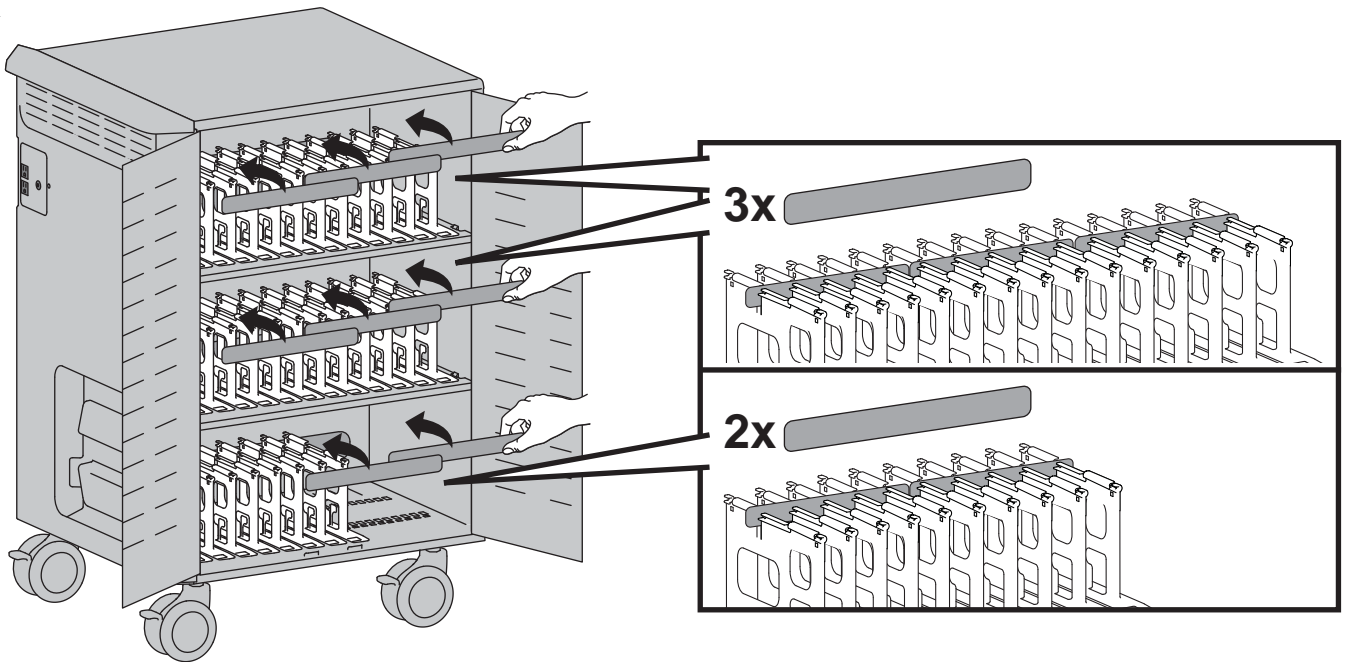

30x

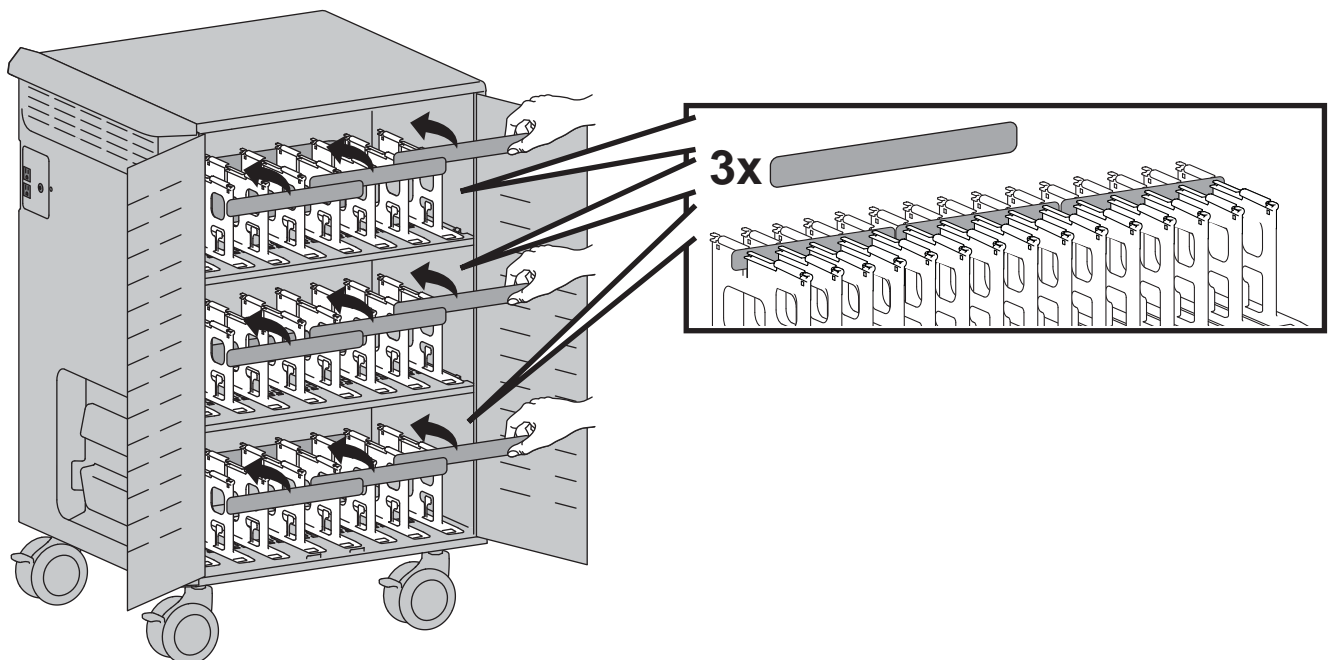

4 Remove back panel.

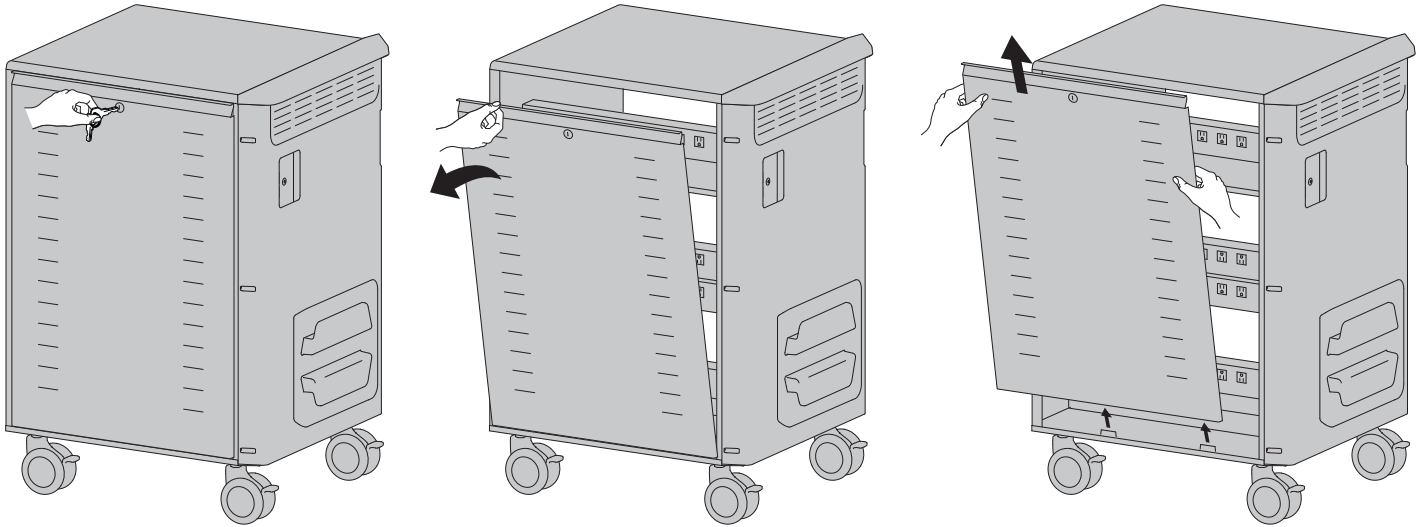

5 Plug in and route power cables.

There are different instructions for each type of power cable. Follow the instructions that match your style power cable.

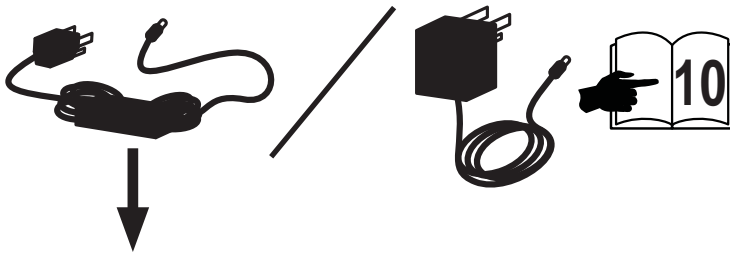

- Plug in the power cables for the top shelf. Use the top row of outlets, and for the 40 device configuration, every other outlet on the second row. Store the power cables in the top basket.
- Route the device plugs between the basket and the top outlet row and up through the top of the dividers. Make sure there is enough slack in cable to plug into device.
- Bundle cables and store in top basket.

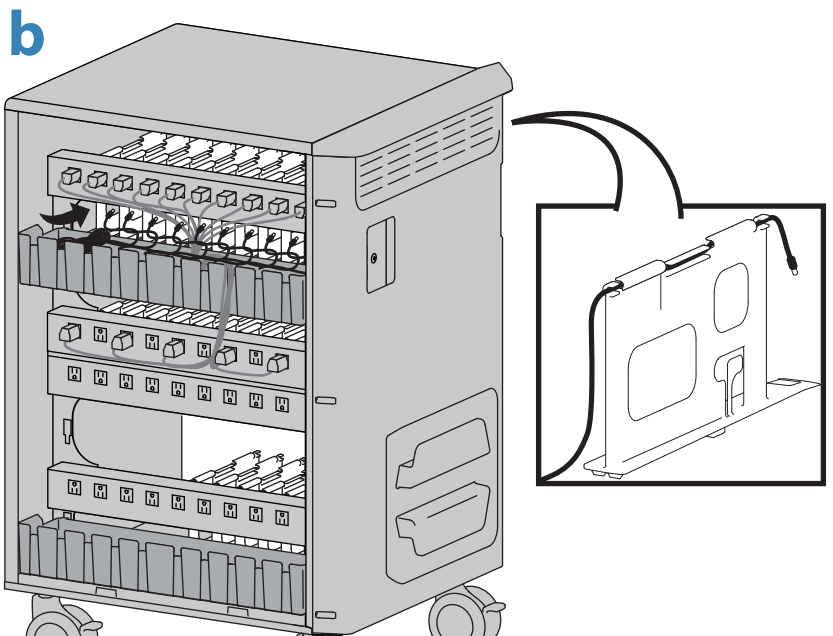
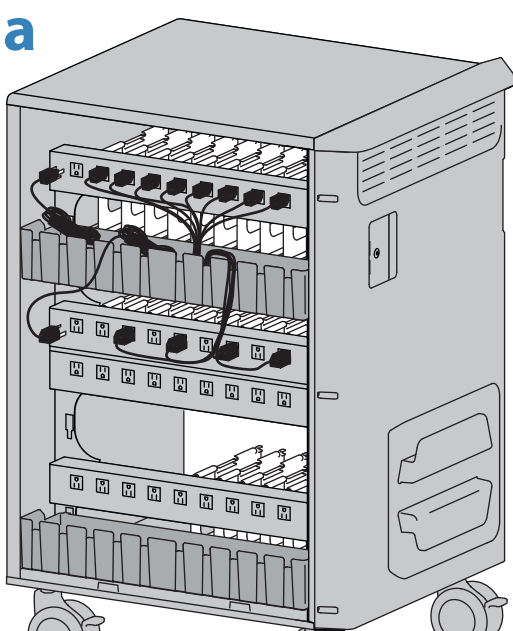



- d. Plug in the power cables for the Middle shelf. Use the entire third outlet row, and for the 40 device configuration, the remaining outlets on the second row. Store the power cables from the second outlet row in the top basket and the power cables from the third row in the bottom basket.
- e. Route the device plugs under the third outlet row and up through the top of the dividers. Make sure there is enough slack in cable to plug into device.
- f. Bundle cables and store in the baskets.

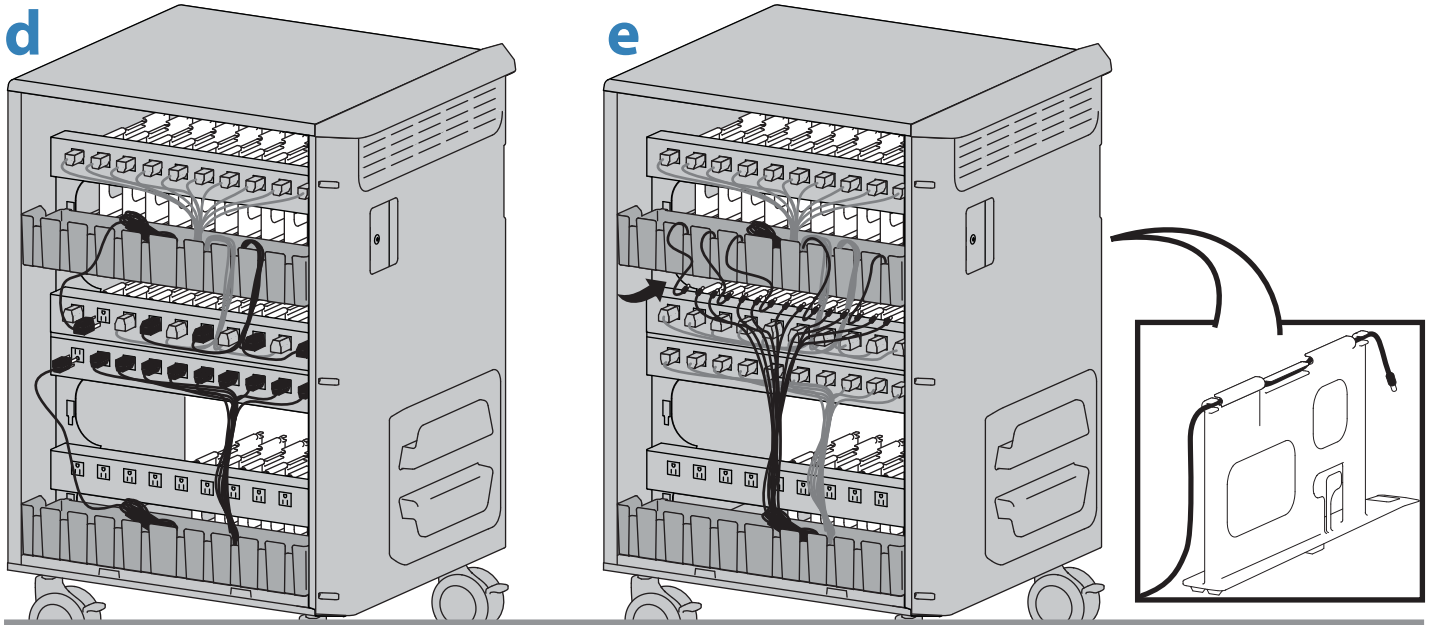

- g. Plug in the power cables for the bottom shelf. Use the bottom row of outlets. Store the power cables in the bottom basket.
- h. Route the device plugs between the basket and the bottom outlet row and up through the top of the dividers. Make sure there is enough slack in cable to plug into device.
- i. Bundle cables and store in bottom basket.

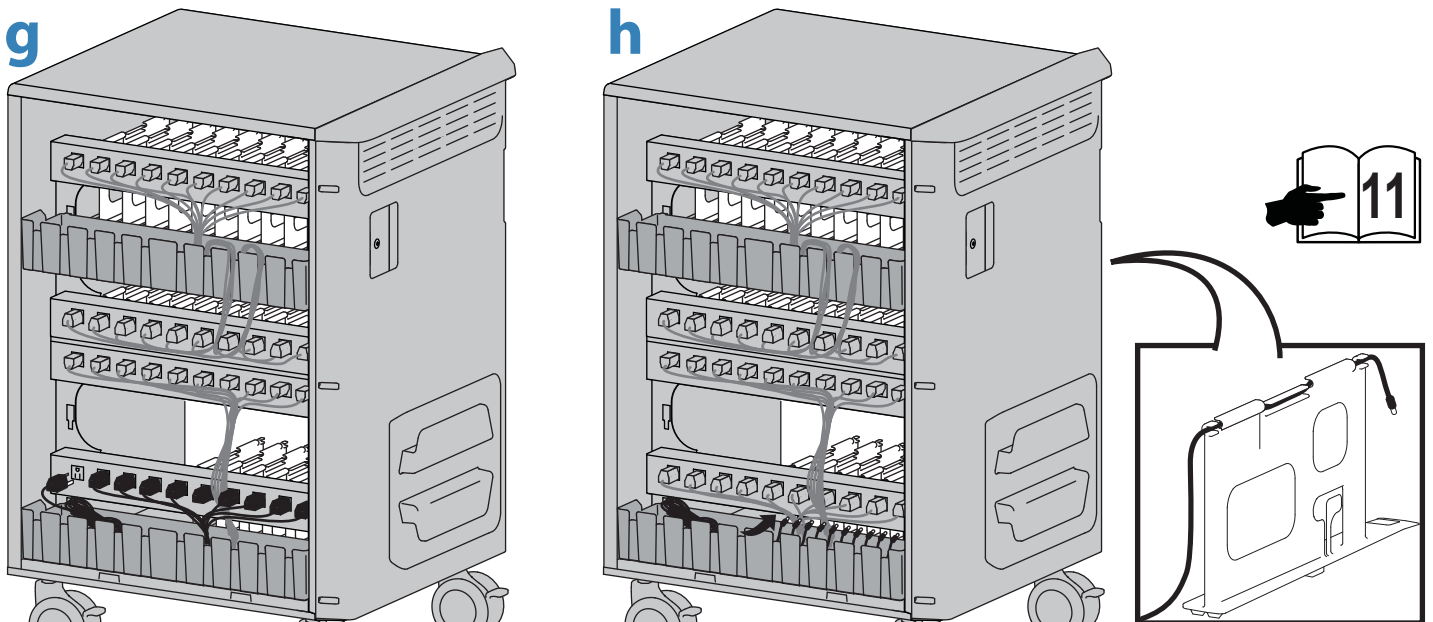

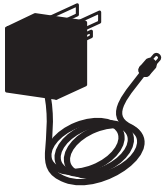

Remove the baskets designed to hold the power supplies that are not present with this type of power cable.

- Lift basket up to unlock tab.
- Pull basket out.
- Lift bottom basket up to unlock tab then pull out.

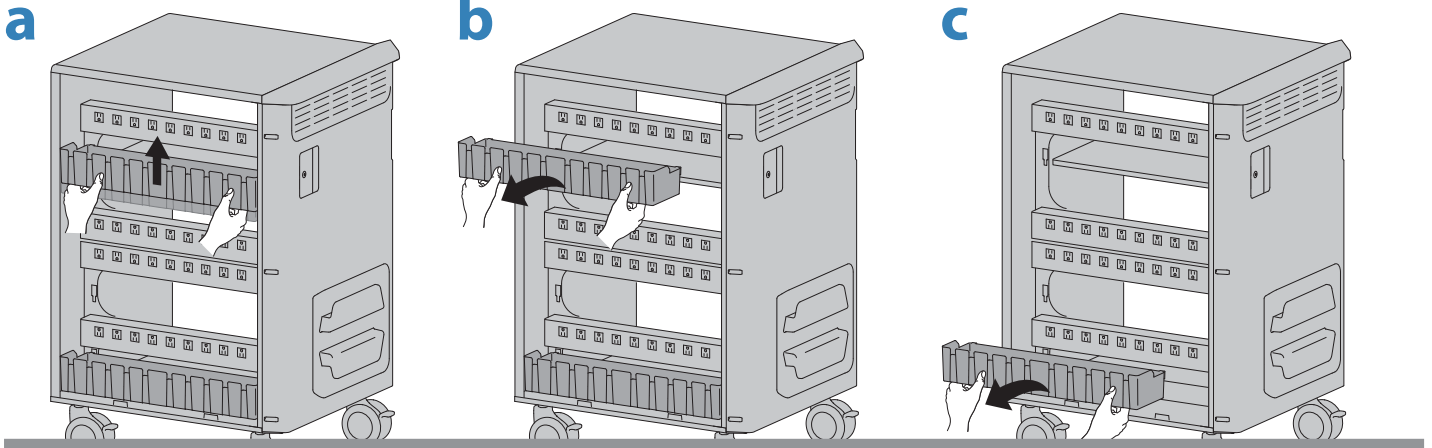

d. Plug in the power cables for the top shelf. Use the top row of outlets, and for the 40 device configuration, every other outlet on the second row. Route the device plugs under the top outlet row and up through the top of the dividers. Make sure there is enough slack in cable to plug into device.

e. Plug in the power cables for the Middle shelf. Use the third row, and for the 40 device configuration, the remaining outlets on the second row. Route the device plugs under the third outlet row and up through the top of the dividers. Make sure there is enough slack in cable to plug into device.

f. Plug in the power cables for the bottom shelf. Use the bottom row of outlets. Route the device plugs under the bottom outlet row and up through the top of the dividers. Make sure there is enough slack in cable to plug into device.

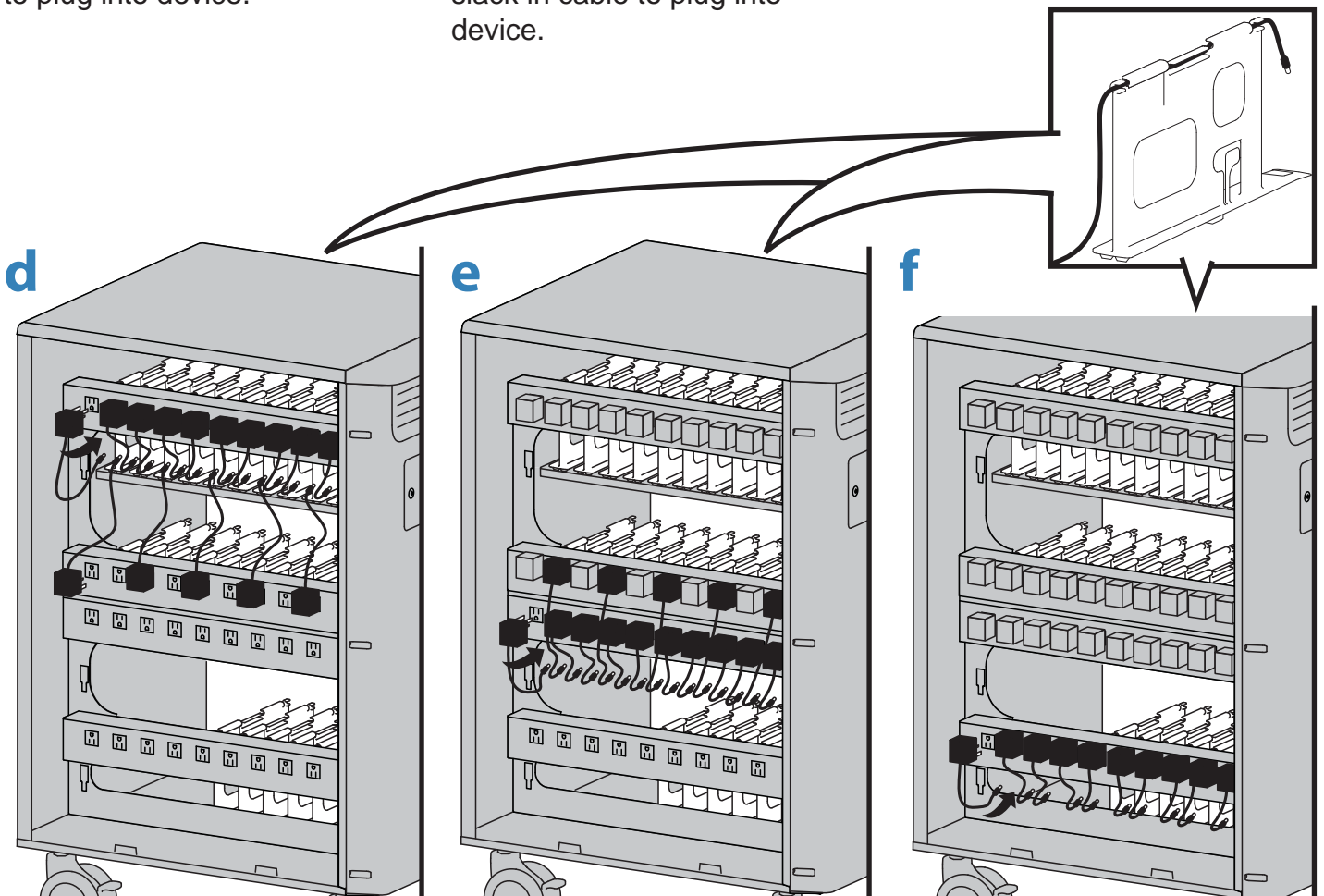

6 Attach back panel.

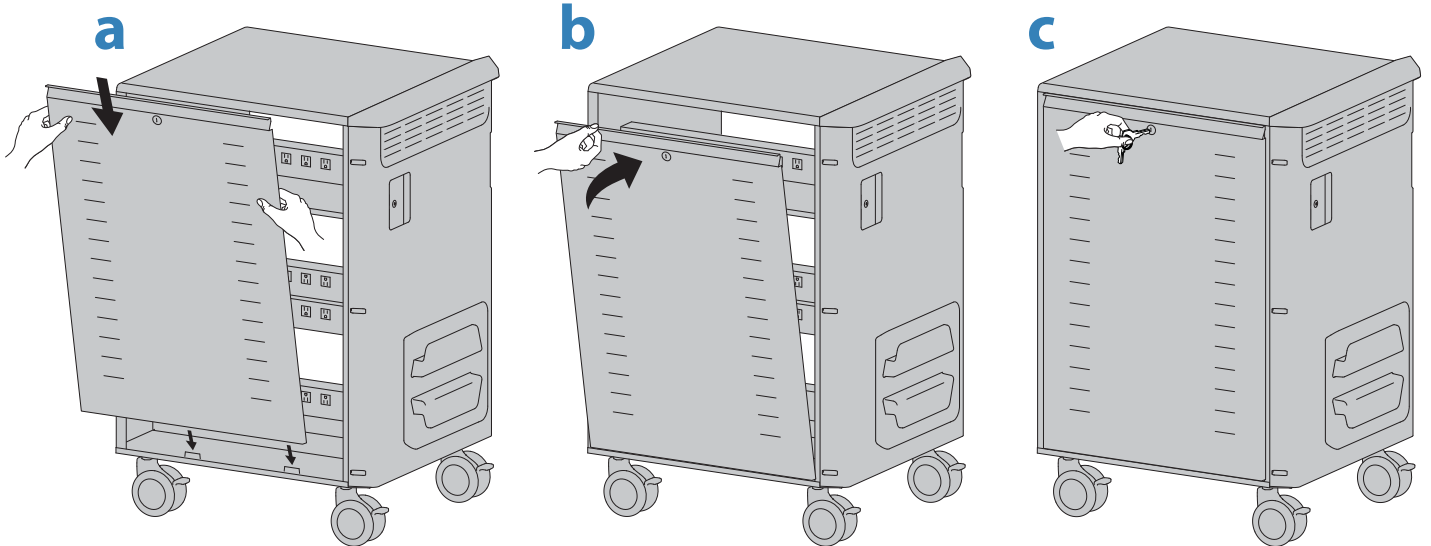

Optional Wireless Access Point (WAP) (not included).

7 Unplug power cable from cart and remove side cover.

⚠ WARNING
MOVING PARTS CAN CRUSH AND CUT
Unplug power cord.
DO NOT place hands on or near fans.
Placing hands on or near fans may cause equipment damage and/or serious personal injury.



828-196

⚠ WARNING: MOVING PARTS CAN CRUSH AND CUT. Unplug power cord. DO NOT place hands on or near fans. Placing hands on or near fans may cause equipment damage and/or serious personal injury.

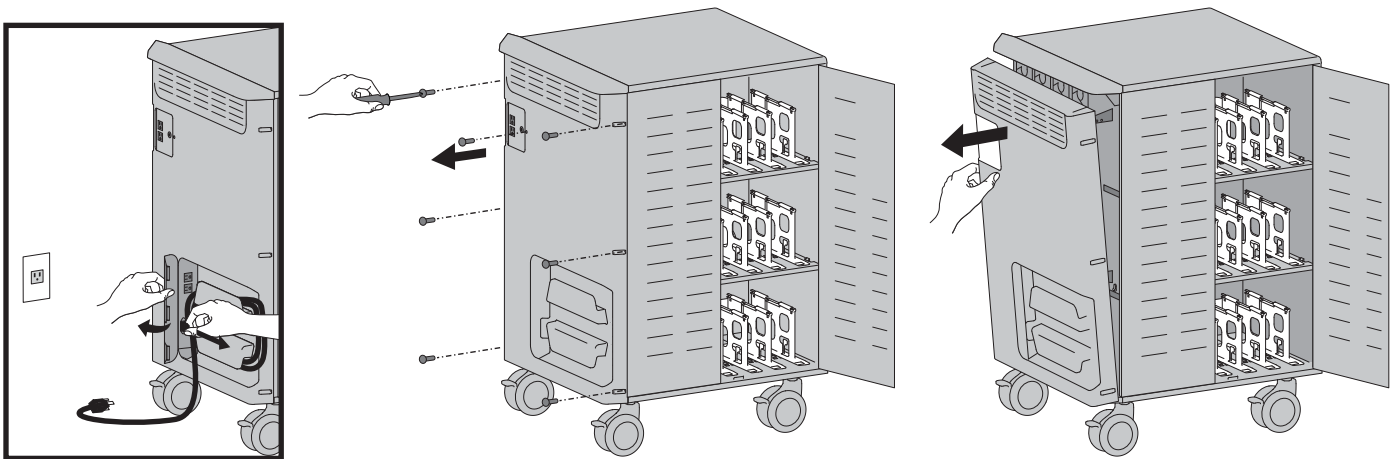

8 Attach WAP with velcro strap.
Plug WAP into Auxiliary outlet.



Access door to unplug WAP.

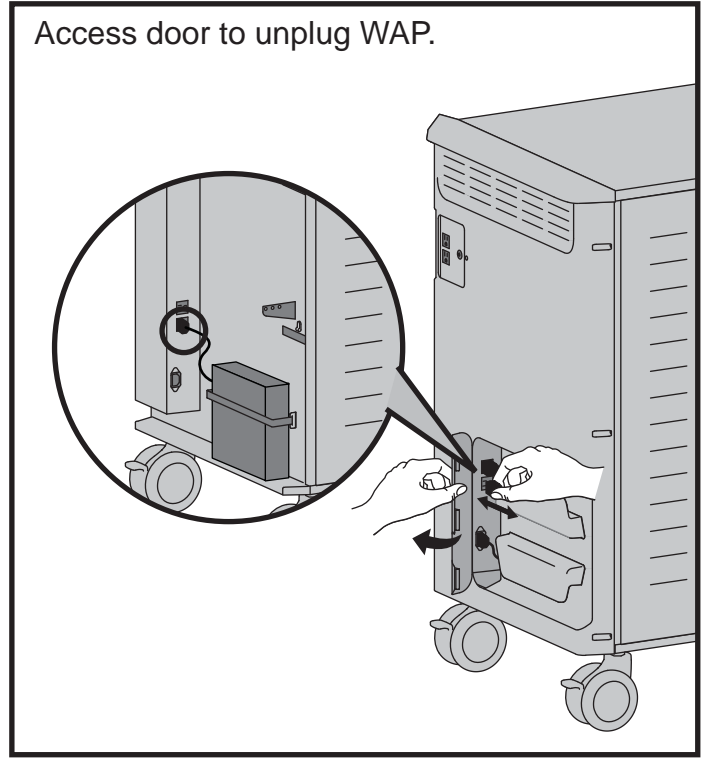

9 Attach side cover and plug power cable back into cart.
NOTE: Route WAP Ethernet cable through side cover access door.

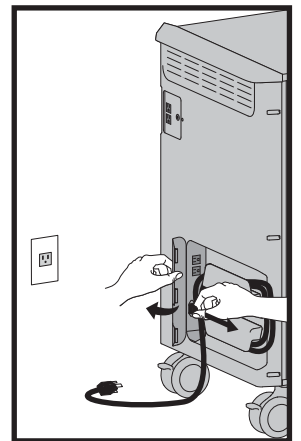
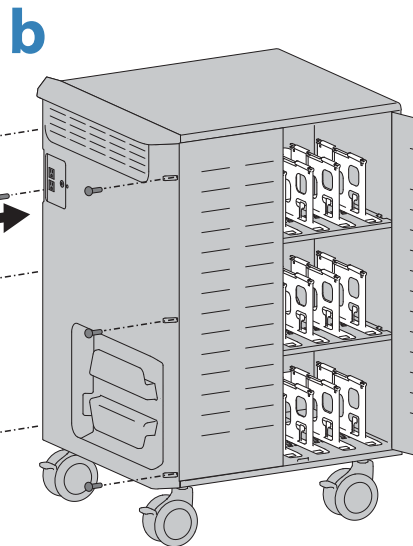
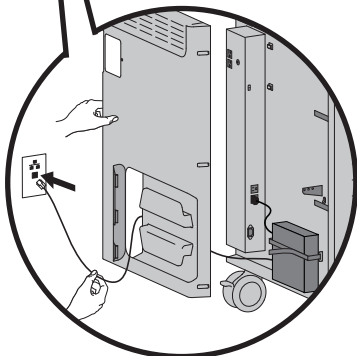
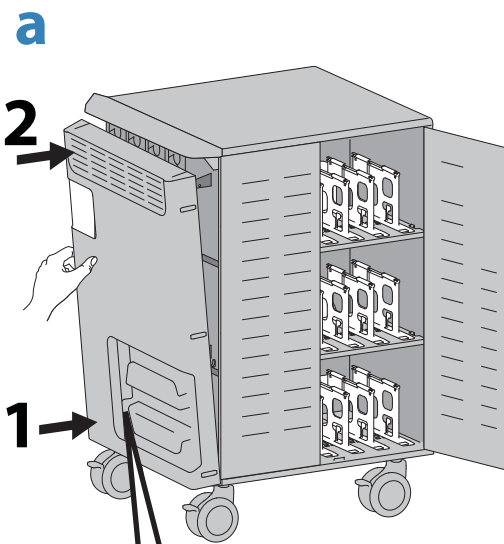

10 Plug in and insert devices.

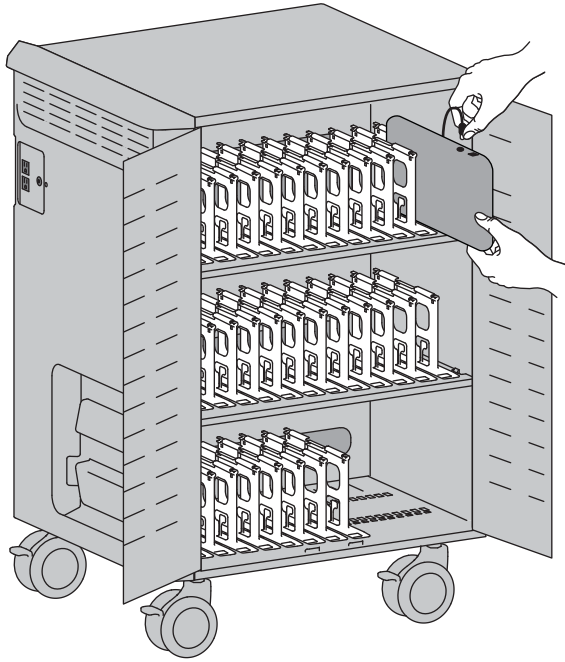

11 Plug in power cable and turn cart power on.

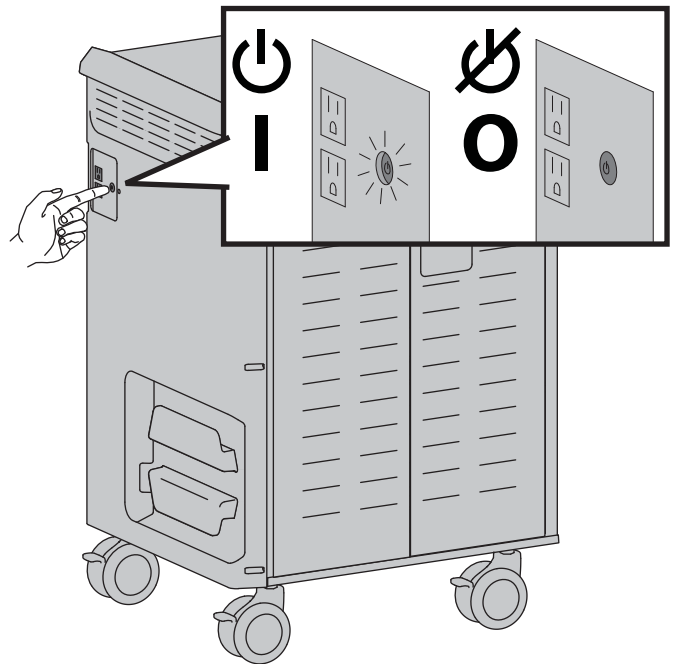
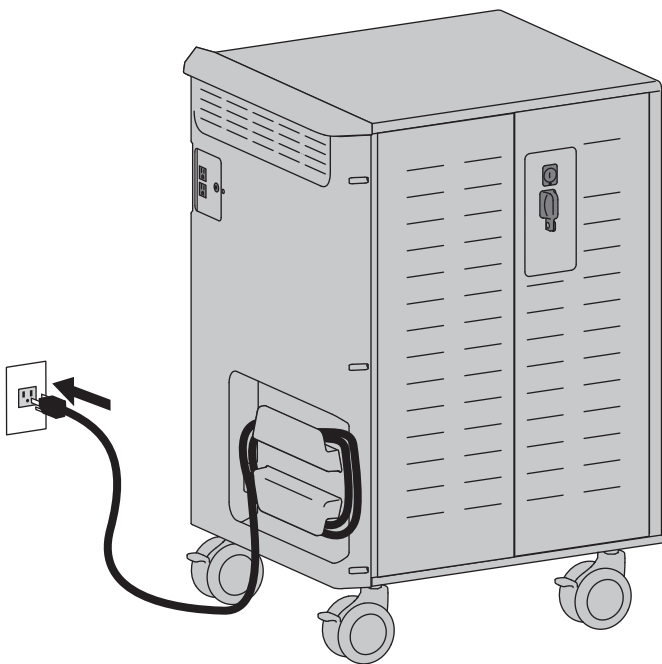

Cleaning and Maintenance

 **WARNING:** Failure to observe the following safety notices may result in serious personal injury or equipment damage.

Inspect for damage, dirt and debris on a regular basis. All paint and plastic components used in the Cart will withstand cleaning by most commonly used, diluted, non-abrasive solutions such as quaternary ammonia compounds, ammonia enzyme cleaners, bleach, or alcohol solutions. It is recommended that any cleaning solution be tested on a small, inconspicuous area to ensure it does not harm the surface of the Cart.

- Marks from permanent marker, dry-erase marker, and pens can be removed with 91% isopropyl alcohol and a soft cloth.
- Iodine stains can be removed with commonly used cleaners and a soft cloth.
- Do not use steel wool or other abrasive materials that may damage the surface finish.

 **Electrical:** To avoid risk of electric shock, do not expose electrical components to water, cleaning solutions or other potentially corrosive liquids or substances.

 **Electrical:** Do not immerse Cart or Cart components in liquid or allow liquids to flow into the Cart. Wipe all cleaners off surface immediately using a damp cloth. Dry the surface thoroughly after cleaning.

 **Electrical:** Do not use flammable cleaners on Cart surfaces.

 **CAUTION:** Adjustment, Service, Replacement - DO NOT attempt to adjust, service or replace any part of the Cart unless directed to do so through Ergotron-approved documentation (i.e. installation instructions). Only Ergotron, Inc. or an Ergotron-certified entity may adjust, service or replace Cart components. If any component on the Cart is missing or damaged, the Cart must not be used. Contact Ergotron immediately to request a replacement part.

 **CAUTION:** Casters - Check casters periodically to make sure they are clean and free of debris that would prevent smooth travel. Avoid moving Cart across uneven, dirty, or damaged surfaces.

 **CAUTION:** Customer Equipment- Make sure equipment is balanced and installed securely to Cart. Contact Ergotron for information about moving Cart components.

Equipment Electrical Safety

There are specific risks associated with the use of equipment having power cables. You must be aware of, and avoid these risks when the Cart is located in close proximity to children.

 **WARNING:** Failure to observe the following Electrical Safety notices can result in fire or death by electric shock.

 **Electrical cables can be hazardous.** Misuse can result in fire or death by electrical shock.

- Double Pole / Neutral Fusing
- Inspect power cables thoroughly before each use.
- Do not use cables that are damaged.
- Insert the plug completely into the outlet.
- Grasp the plug to remove from the outlet.
- Do not unplug by pulling on the cable.
- Do not use excessive force to make connections.
- Do not plug the cable into an extension cable.
- Do not remove, bend or modify any metal prongs or pins of cable.
- Do not drive, drag or place objects over the cable.
- Do not walk on the cable.
- Avoid overheating. Uncoil the cable and do not cover it with any material.
- Do not run cable through doorways, holes in ceilings, walls or floors.

 **Keep the Cart away from water.**

- Do not use it when wet.
- Do not place the Cart in close proximity to flammable liquids or gases.

 **CAUTION:** The power disconnect for this equipment is the AC power cable. Therefore the socket outlet should be easily accessible and should be installed near the equipment.

Safe Use Recommendations

There are specific risks associated with the use of Cart when moving or stationary (for charging or storage). You must be aware of, and avoid these risks when the Cart is located in close proximity to children.

 **WARNING:** Failure to observe the following Cart Use Safety notices may result in serious personal injury or equipment damage.

 **WARNING:** Death or serious injury may occur when children climb on audio and/or video equipment furniture. A remote control or toys placed on the furnishing may encourage a child to climb on the furnishing and as a result the furnishing may tip over on to the child.

 **WARNING:** Relocating audio and/or video equipment to furniture not specifically designed to support audio and/or video equipment may result in death or serious injury due to the furnishing collapsing or over turning onto a child.

Only Adults should move this cart.

- Do not allow anyone to sit, stand, or climb on the Cart.
- Do not lift the Cart from the bottom.
- Do not block the fans and vent openings. To prevent overheating, leave at least 127 mm (5-inch) clearance around fans and vents.

The Cart is designed to be used indoors only.

- Do not use the Cart to transport or store equipment other than what has been noted in this guide.
- Do not use the Cart to store liquids or cleaning supplies.
- Do not place heavy objects on the Cart surface or shelf.
 - The maximum weight capacity of the top surface is 11.4 kg (25 lb).
 - The maximum weight capacity of the shelf is 34.7 kg (76.5 lb).
 - No TV/Monitor is to be used on top of cart.

Moving the Cart

- Before moving the Cart:
 1. Disconnect the power cable from the wall.
 2. Disconnect Ethernet cable from the wall if present.
 3. Make sure the cable is wrapped and secure.
 4. Close and lock the doors.
 5. Remove items from the top work surface.
 6. Unlock the casters.
- Push (do not pull) the Cart for optimum maneuverability and to prevent muscle strain.
- Do not move the Cart across rough, uneven or irregular surfaces such as gravel.

Parking the Cart

Observe these safety alerts for times when the cart is stationary:

- Do not park the Cart in areas of heavy traffic.
- Do not run cables through doorways, holes in ceilings, walls, or floors.
- Do not run cables across hallways, classrooms, or other areas where they will be walked on.
- Do not leave Cart unattended in areas where children have access.
- Keep Cart doors closed and locked whenever it is unattended or parked for charging or storage.
- Keep Cart casters locked whenever it is unattended.



DANGER! Electrical cables can be hazardous.
Misuse can result in fire or death by electrical shock.



Specifications

This device complies with Part 15 of the FCC Rules. Operation is subject to the following two conditions:

- 1) This device may not cause harmful interference.
- 2) This device must accept any interference received, including interference that may cause undesired operation.

CAN ICES3(A)/NMB-3(A).

Changes or modifications not expressly approved by the Ergotron could void the user's authority to operate the equipment.
Intended for institutional use.

この装置は、クラスA情報技術装置です。この装置を家庭環境で使用すると電波妨害を引き起こすことがあります。この場合には使用者が適切な対策を講ずるよう要求されることがあります。

VCCI-A

Cart dimensions
30.3"W x 45.4"H x 26.1"D (77x115x66 cm)

Shipping dimensions
37"W x 30"D x 52"H (94x75x132 cm)

Cart weight (without equipment)
175 lb (79 kg)

Shipping weight
221 lb (100 kg)

Rated weight capacity
Top Work Surface
25 lb (11.3 kg)

Power system
100-120V~, 12A, 50/60Hz
Maximum input for 5 devices cannot exceed 8.5A
or
220-240V~, 10A, 50/60Hz
Maximum input for 5 devices cannot exceed 4.0A

Device Slot Size
17.1"W x 11.2"H (43.4x28.4 cm)
Device with case and power cord installed must fit within these dimensions.

Environmental
Temperature range:
Operating 0° to 30°C (32° to 86°F)
Storage -40° to 60°C (-40° to 140°F)

Max Dimensions of WAP
10"W x 10"H x 2.2"D (25.4x25.4x5.6 cm)

Cooling/ventilation
Four 12V DC fans, ventilated doors and side panel

Relative humidity (maximum):
Operating 10%–90% (non condensing)
Storage 5%–95% (non condensing)

External power outlet(s)
One or two outlets, depending on region
100-120V~, 4A max, 50/60 Hz or
220-240V~, 2A max, 50/60 Hz

Altitude (maximum): 2000 m (6,562 ft)

WAP and Switch Outlets
100/120V~, 4A max, 50/60 Hz or
220-240V~, 2A max, 50/60 Hz

Certification:
UL 60950 Safety of Information Technology Equipment, CAN/CSA C22
2 No. 60950; UL 1678 Household, Commercial, and Institutional-Use
Carts, Stands, and Entertainment Centers for Use with Audio and/or Video
Equipment.
ICES-003 Issue 5, Class A
FCC Part 15 Class A
RoHS and REACH compliant material used.

For Warranty visit: www.ergotron.com/warranty

For Service visit: www.ergotron.com

For local customer care phone numbers visit: <http://contact.ergotron.com>



NOTE: When contacting customer service, reference the serial number.

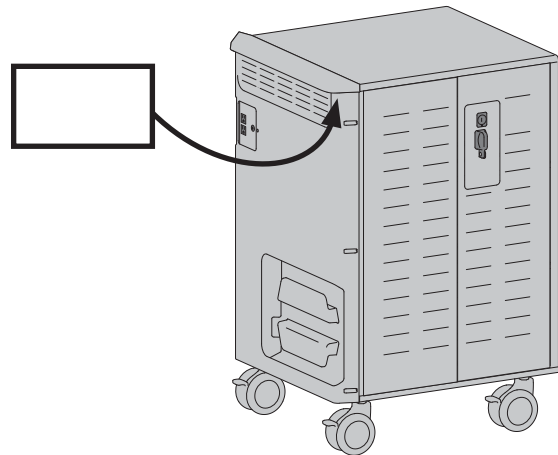

Americas Sales and Corporate Headquarters

1181 Trapp Rd.
St. Paul, MN USA
(800) 888-8458
+1-651-681-7600
www.ergotron.com
sales@ergotron.com

EMEA Sales

Amersfoort, The Netherlands
+31 33 45 45 600
www.ergotron.com
info.eu@ergotron.com

APAC Sales

Tokyo, Japan
www.ergotron.com
apaccustomerservice@ergotron.com

Worldwide OEM Sales

www.ergotron.com
info.oem@ergotron.com

© 2015 Ergotron, Inc. All rights reserved.

ERGOTRON®

While Ergotron, Inc. makes every effort to provide accurate and complete information on the installation and use of its products, it will not be held liable for any editorial errors or omissions (including those made in the process of translation from English to another language), or for incidental, special or consequential damages of any nature resulting from furnishing this instruction and performance of equipment in connection with this instruction. Ergotron, Inc. reserves the right to make changes in the product design and/or product documentation without notification to its users. For the most current product information or to know if this document is available in languages other than those herein, please contact Ergotron. No part of this publication may be reproduced, stored in a retrieval system, or transmitted in any form or by any means, electronic, mechanical, photocopying, recording or otherwise without the prior written consent of Ergotron, Inc., 1181 Trapp Road, Eagan, Minnesota, 55121, USA. Patents Pending and Patented U.S. & Foreign. Ergotron is a registered trademark of Ergotron, Inc.