

EXTECH

Quick Start

600 A True RMS AC/ DC Clamp Meter with IR Thermometer

MODEL EX623A

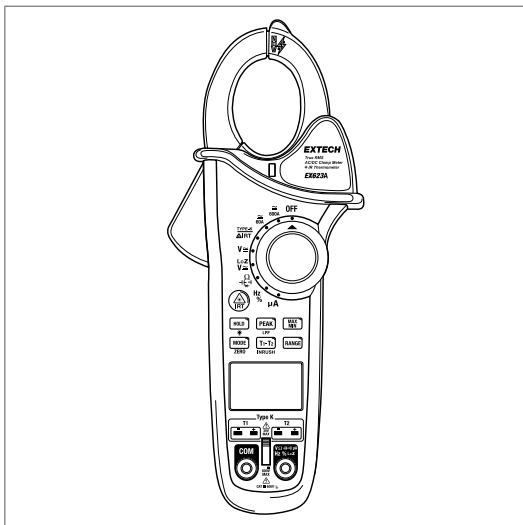

Quick Start (EN)

INTRODUCTION

The Extech EX623A measures temperature with its infrared (IR) detector and dual Type K thermometer inputs. Electrical measurements include AC/DC Voltage/Current, Resistance/Continuity, Capacitance, Frequency/Duty Cycle, Diode, and a non-contact voltage detector. This meter features a water-proof, rugged design intended for industrial use.

DOCUMENTATION ADVISORY

This Quick Start is intended for setup and reference only, please download and read the User Manual before taking measurements (link below). Additional translations of this Quick Start may also be available.

<https://support.flir.com>

SAFETY



WARNING

- For indoor use only.
- Improper use of this meter can cause damage, shock, injury or death.
- Set the function switch to the appropriate position before measuring.
- When measuring voltage do not switch to the current or resistance modes.
- Do not measure current on a circuit whose voltage > 600 V.
- When changing ranges, always disconnect the test leads from the circuit under test.
- Voltage checks on electrical outlets can be difficult and misleading because of the uncertainty of connection to the recessed electrical contacts. If connection to the contacts is not made, the outlet may be live when the meter indicates no voltage.



CAUTION

- Always remove the test leads before replacing the battery or fuses.
- Inspect the condition of the test leads and the meter itself for any damage before operating the meter.
- Use caution when making measurements if the voltage > 35 V DC or 25 V AC RMS.
- Always discharge capacitors and remove power from the device under test before performing Diode, Resistance or Continuity tests.
- If the equipment is used in a manner not specified by the manufacturer, the protection provided by the equipment may be impaired.
- **Do not directly view, point, or reflect the laser pointer towards the eyes.**
- Use of controls or adjustments or performance of procedures other than those specified herein may result in hazardous radiation exposure.



LASER RADIATION - DO NOT STARE INTO BEAM
RAYONNEMENT LASER NE REGARDEZ PAS LE FAISCEAU
CLASS 2 CONSUMER LASER PRODUCT

WAVELENGTH: 650nm MAX OUTPUT POWER < 1mW

IEC 60825-1:2014

COMPLIES WITH 21 CFR 1040.10

AND 1040.11 EXCEPT FOR

CONFORMANCE WITH IEC 60825-1

ED. 3 AS DESCRIBED IN LASER

NOTICE NO. 56, DATED MAY 8, 2019.

EN 60825-1:2014/A11:2021, EN 50689:2021

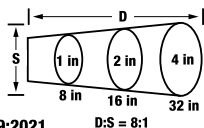

Laser light beam divergence

< 0.5 in. (12 mm) spot diameter at a distance of 32.8 ft. (10 m)

Maximum Input Ranges

Function	Maximum Input
AC/DC Current (A)	600 A AC/DC
AC/DC Current (μ A)	6000 μ A AC/DC
AC/DC Voltage and LoZ Voltage	600 V AC/DC
Resistance, Capacitance, Frequency, Diode	250 V AC/DC
Type K Temperature	30 V DC, 24 V AC



METER DESCRIPTION

1. Non-contact voltage (NCV) detector.
2. Current clamp.
3. NCV indicator.
4. Clamp trigger.
5. Function switch.
6. Control buttons.
7. Backlit LCD.
8. Thermocouple inputs.
9. Negative test lead jack.
10. Positive test lead jack.
11. Input shutter switch.

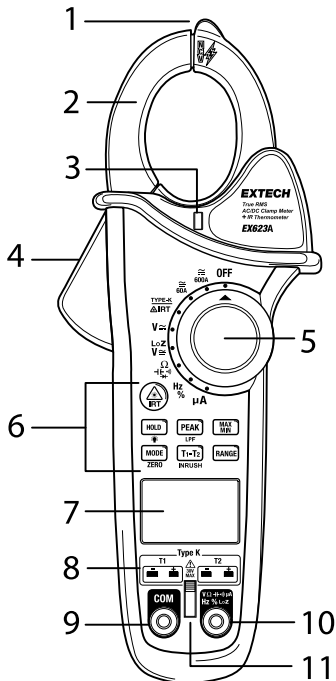
Battery compartment, IR lens, and laser pointer lens on back of meter.



CONTROL BUTTONS

	Press and hold to display the temperature of the targeted spot.
	Data Hold. Short press to freeze/unfreeze the reading. Long press to switch the backlight on or off.
	Peak: Short press to show/hide the measured current's signal peak. Low Pass Filter (LPF): Long press to engage or remove the low pass filter, for AC voltage measurements.

MAX MIN	Short press to step through MAX and MIN readings and then back to normal display mode.
MODE ZERO	Short press to select an alternate mode for the function in use. For example, select AC or DC when measuring voltage. Long press to activate the DC current zero function.
T1-T2 INRUSH	With a thermocouple connected to one or both inputs, choose the display configuration (T1, T2, or T1 minus T2). Long press, when measuring AC current, to switch on/off the in-rush capture mode.
RANGE	Short press to switch to the manual range, and then to step through the ranges. Long press to return to Auto range.

METER POWER

The meter is powered by one 9 V battery. The compartment is located on the back of the meter (under the tilt stand) secured by the two black Phillips screws. The meter automatically switches off after approximately 15 minutes.

FEATURES

Input Shutter Switch

Set the switch to proper position for the measurements shown in the image below.

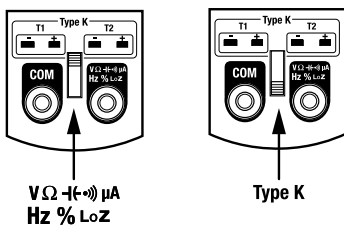

Automatic and Manual Range

In the voltage, resistance, capacitance, frequency, and μA current functions, the meter automatically selects the optimum range. To use manual range, press the **RANGE** button, subsequent presses will step through the ranges. Long press **RANGE** to return to the Auto range mode.

Data Hold

To freeze the displayed reading, press the **HOLD** button, the HOLD icon will appear. Press the **HOLD** button to return to normal operation.

Maximum and Minimum Readings

Press the **MAX/MIN** button to toggle the maximum and minimum reading displays. The **MAX** and **MIN** display icons show the selected mode. Long press the **MAX/MIN** button to exit.

Peak Max

When measuring AC voltage, press the **PEAK** button to activate the peak capture circuit. The **P-MAX** display icon will appear and the meter will now display the measured signal's peak. Press the **PEAK** button again to exit.

Relative (REL) Mode

The Relative feature allows you to make measurements relative to a stored reference. The displayed value is the difference between the reference and the measured value.

Press the **REL** button to store the reference (REL will appear). The display will now indicate the difference between the stored value and the measured value. Press **REL** to exit.

MEASURING CURRENT WITH THE CLAMP



WARNING

Disconnect the test leads before making clamp measurements.

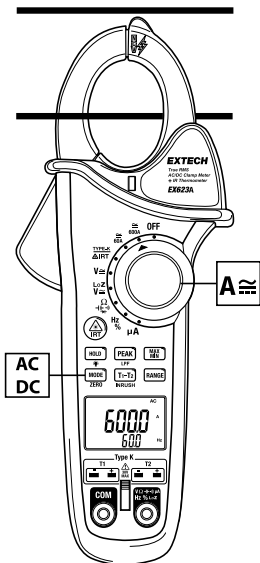

1. Set the function switch to the **60A** or **600A** position.
2. Press **MODE** to select AC or DC.
3. Press the trigger to open jaw. Fully enclose only **one** conductor as shown.
4. Read the current value in the display.

μA CURRENT MEASUREMENTS

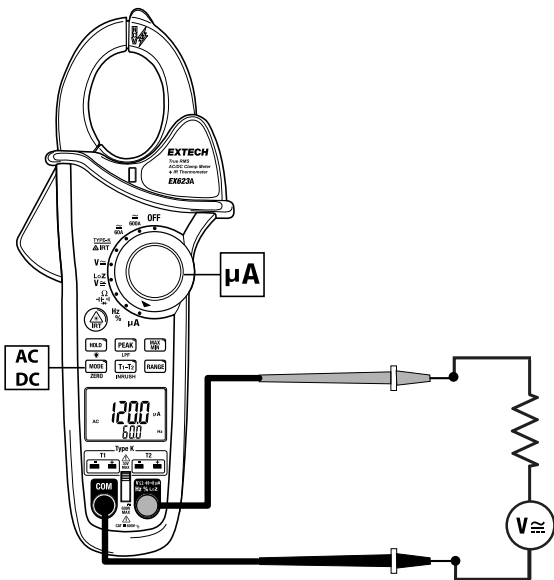

1. Slide the input shutter to the upper position.
2. Set the function switch to the μA position.
3. Press **MODE** to select AC or DC.
4. Insert the black test lead plug into the negative **COM** jack. Insert the red test lead plug into the positive μA jack.
5. Turn power off to the circuit under test, and make a break in the circuit.
6. Insert the meter in series with the circuit by touching the black test probe tip to the negative side of the break, and the red test probe tip to the positive side of the break.
7. Switch circuit power on.
8. Read the current value in the display. For AC, the frequency will be shown on the lower display digits.

MEASURING VOLTAGE, FREQUENCY, RESISTANCE, DIODE, CAPACITANCE

These measurements are made with the test leads placed 'across' the device or circuit under test (in parallel).



WARNING

Risk of electrocution. High-voltage AC/DC circuits are extremely dangerous and should be measured with great care.

Do not measure resistance, diode, or capacitance on powered devices.

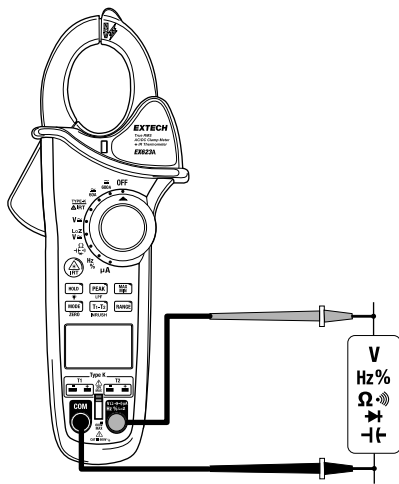

1. Rotate the function switch to the desired function. Press **MODE** to select the desired mode.
2. Insert the black test lead plug into the negative **COM** jack. Insert the red test lead plug into the positive jack.
3. Touch the black test probe tip to the negative side of the circuit. Touch the red test probe tip to the positive side.
4. Read the measurement on the display.

IR TEMPERATURE MEASUREMENTS



CAUTION

Do not directly view or point the laser at an eye.

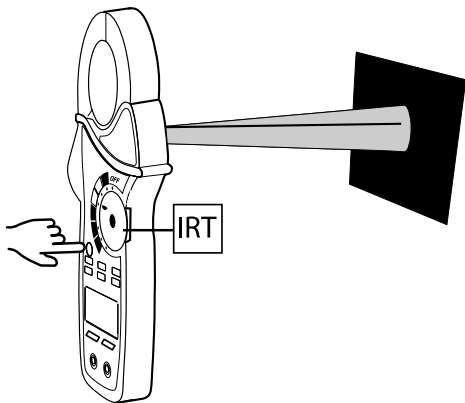

1. Set the function switch to the **IRT** position.
2. Press and hold the **IRT** button and aim the laser pointer toward a surface.
3. With the **IRT** button still depressed, long press **MODE** to toggle °F and °C.
4. Read the temperature measurement on the display. Note that the distance-to-spot ratio is 8:1 for this meter, for example the measured spot is 1 in. in diameter at a distance of 8 in.

TYPE K TEMPERATURE MEASUREMENTS



CAUTION

The supplied thermocouple is rated for 482°F (250°C) maximum.

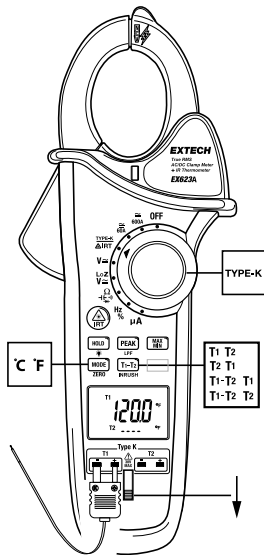

1. Place the input shutter switch in the lower position.
2. Rotate the function switch to the **TYPE K** position. Press **MODE** to select °F or °C.
3. Insert the temperature probe(s) into the thermocouple jacks, observing correct polarity.
4. Touch the probe tip(s) to the surface under test. Read the temperature measurement on the display. Use the **T1-T2** button to select a display mode.

NON-CONTACT VOLTAGE DETECTOR

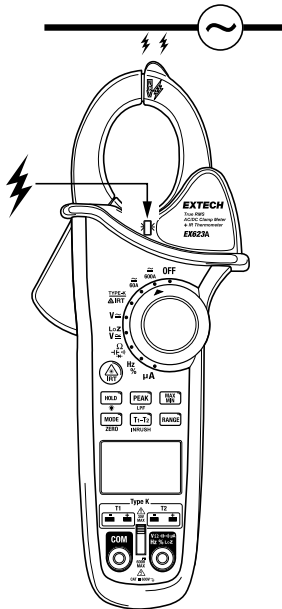

1. Remove the test leads from the meter.
2. Set the function switch to any position.
3. Place the clamp tip near, or on, the conductor under test.
4. If AC voltage is present, the red NCV detector LED will switch on. The detectable voltage range is 100 to 600 V AC.

BASIC SPECIFICATIONS

For complete specifications, please download the user manual.

Display	Backlit LCD with bar graph
Over-range indication	OL display
Battery power	9 V battery
Operating temperature	32 to 122°F (0 to 50°C)
Operating humidity	80% RH max. up to 87°F (31°C)
Dimensions	9.5 x 3.8 x 1.75 in. (241 x 96 x 44.5 mm)
Weight	11.1 oz. (315 g)
Safety	Meter: Over-voltage CAT III 600 V, Pollution Degree 2 Supplied test leads: Over-voltage CAT IV 600 V, CAT III 1000 V
Agency approvals	ETL, CE, UKCA
Fuse types	200 mA (600 V) ceramic fast blow, 5 x 20 mm
Input impedance	> 10 MΩ (Voltage AC/DC)
AC bandwidth	50 Hz to 1 kHz (AC voltage); 50/60 Hz (AC current)
AC response	True RMS (AC voltage/current)
Peak detector	> 1 ms
Supplied Thermocouple	Type K; rated 482°F (250°C) maximum

CUSTOMER SUPPORT

Customer Support Local Telephone List:

<https://support.flir.com/contact>

Returns (RMA):

<https://customer.flir.com/Home>

WARRANTY

Teledyne FLIR warrants this Extech brand instrument to be free of defects in parts and workmanship for two years from date of shipment. To view the full warranty text, please visit the support site, link below.

<https://www.flir.com/support-center/warranty/>

Website

<http://www.flir.com>

Customer support

<http://support.flir.com>

Copyright

© 2024, FLIR Systems, Inc. All rights reserved worldwide.

Disclaimer

Specifications subject to change without further notice. Models and accessories subject to regional market considerations. License procedures may apply.

Products described herein may be subject to US Export Regulations. Please refer to exportquestions@flir.com with any questions.

Publ. No.: NAS100185
Release: AE
Commit: 96702
Head: 98047
Language: en-US
Modified: 2024-03-29
Formatted: 2024-05-20

