

Technical Specifications

37128

**Touchboards**

205 Westwood Ave, Long Branch, NJ 07740  
Phone: 866-94 BOARDS (26273) / (732)-222-1511  
Fax: (732)-222-7088 | E-mail: sales@touchboards.com



**42"W x 60"L x 30"H**  
**InVision Element Table**  
(with T-Legs and one  
Cove module cutout)

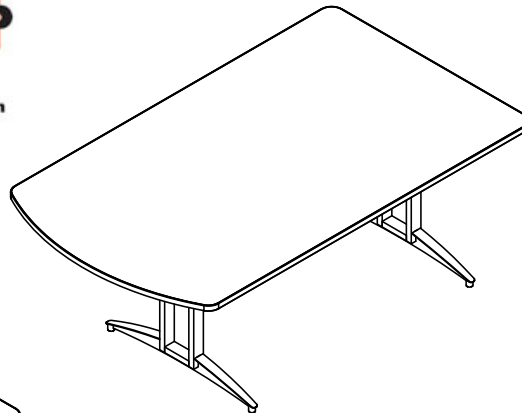

**42"W x 72"L x 30"H**  
**InVision Element Table**  
(with T-Legs and blank  
worksurface)

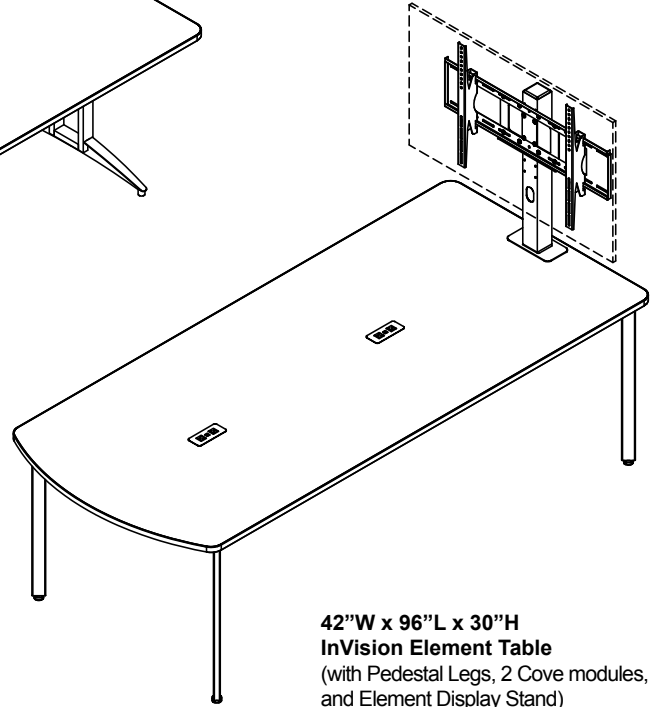

**42"W x 96"L x 30"H**  
**InVision Element Table**  
(with Pedestal Legs, 2 Cove modules,  
and Element Display Stand)

*The InVision Element Table is the next generation of affordable, durable active learning collaboration furniture available for educational or corporate settings. Two leg styles, Three height options, power options, and worksurface lengths in 60", 72", and 96"L give the user the ability to fully configure each table to their specific needs. The Element Display Stand can also be added for large screen monitor viewing.*

**Features and Benefits**

- The best value in the quickly changing collaboration system environment
- Choose from T-Leg or Pedestal legs
- Available in 27"H elementary, 30"H adult, or 42"H standing worksurface heights (*Post legs not available in 42"H*)
- Ships with 1-piece worksurface with matching color edge trim (*some laminate choices use non-matching edge trim*)
- Scratch and impact-resistant high-pressure laminate worksurface
- Durable powder coated steel legs provide a long-lasting finish
- Durable worksurface edge trim
- Worksurface braces provide support to minimize flexing
- ADA-compliant knee clearance under worksurface (42" & 30"H versions)
- Leveling glides keep table level on uneven surfaces
- Cords and wiring can be channeled cleanly using the under-worksurface wiring channel
- Table ships "knocked-down" for lower shipping costs and can be easily assembled at the final location
- Optional Element Display Stand provides ability to attach most monitors (requires worksurface mounting holes)
- SCS Indoor Advantage Certified; meets or exceeds applicable ANSI-BIFMA test standards
- Warranted to be free of all defects in materials and workmanship for 10 years, electrical system 2 years
- Manufactured in Chippewa Falls, WI, USA

**Color Options**  
See spectrumfurniture.com for complete color options and combinations.

# Construction

- The worksurfaces are constructed from 1" thick NAUF (No Added Urea Formaldehyde) composite board plus .030" high-pressure laminate on one face, and a balancing phenolic backer on the opposing face
- Metal components consist of 16-gauge steel
- Worksurface edges are covered with 3mm vinyl (color matching)
- All metal components are finished with a scratch-resistant powder coat epoxy
- Tables are shipped KD (Knocked-Down) and require assembly

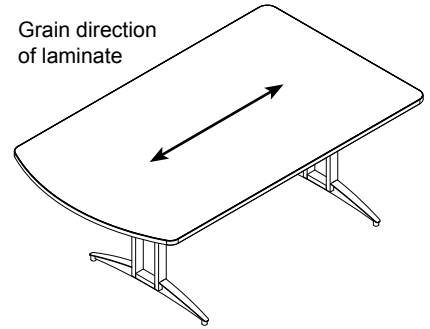

# Specifications

Worksurface sizes available	<ul style="list-style-type: none"> <li>• 42"W [106.7 cm] x 60"L [512.4 cm]</li> <li>• 42"W [106.7 cm] x 72"L [182.9 cm]</li> <li>• 42"W [106.7 cm] x 96"L [243.8 cm]</li> </ul>
Leg styles available	<ul style="list-style-type: none"> <li>• T-Legs (2)</li> <li>• Pedestal (4)</li> </ul>
Worksurface heights available	<ul style="list-style-type: none"> <li>• 27"H [68.6 cm]</li> <li>• 30"H [76.2 cm]</li> <li>• 42"H [106.7 cm] - Available in T-Leg only</li> </ul>
Wiring channel (internal area)	<ul style="list-style-type: none"> <li>• 7"W [17.8 cm] x 7"H [17.8 cm] x 41.2"L [104.6 cm] (60"L table)</li> <li>• 53.2"L [135.1 cm] (72"L table)</li> <li>• 77.2"L [196 cm] (96"L table)</li> </ul>
Seating	See possibilities on p.6
Compatibility	<ul style="list-style-type: none"> <li>• Spectrum does <u>not</u> recommend keyboard trays to be used with the Element Table- especially on 27"H and 30"H models.</li> <li>• The Element Display Stand is <u>not</u> compatible with the 95523 InVision Access Display Shroud, 37124 Dual Display Mount, or 37108 Camera Mount</li> </ul>
ADA-compliance*	<p>The 72"L, and 96"L tables support (1) ADA-compliant seating position on the end</p> <p><i>*Minimum ADA guidelines for knee clearances are 30"W [76.2 cm] x 19"D [48.3 cm] x 27"H [68.6 cm]</i></p> 
Shipping weights (nominal)	<ul style="list-style-type: none"> <li>150 lb [68.1 kg] - 60"L table</li> <li>160 lb [72.6 kg] - 72"L table</li> <li>180 lb [81.7 kg] - 96"L table</li> </ul>

Specifications subject to change without notice

Wiring channel

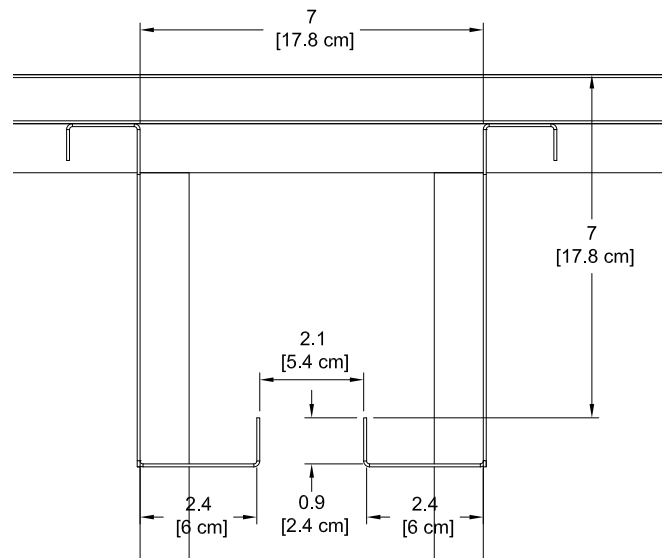
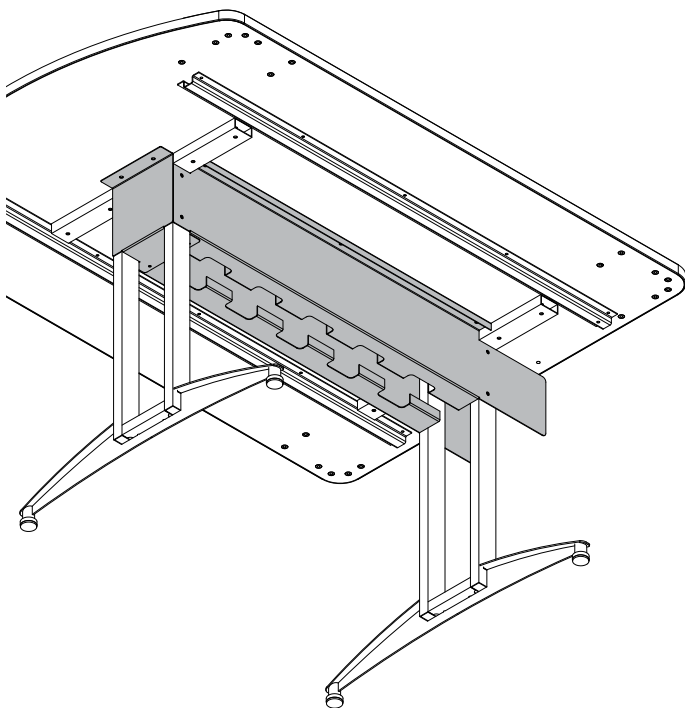

# Configured Options

<b>Configured Options from Factory:</b>		
	<i>Factory-Installed</i>	<i>Customer-Installed</i>
<b>Laminate / Edgeband Color</b>	✓	
<b>Metal Color</b>	✓	
<b>Leg Style</b>	✓	
<b>Worksurface Size</b>	✓	
<b>Cove Power Module(s)</b>		✓
<b>Cove Power Module Color</b>	✓	
<b>Custom Worksurface Cutout</b>	✓	

<b>Accessories:</b>	
<i>Available separately <u>after</u> initial configured purchase (See p.13)</i>	
	<i>Customer-Installed</i>
<b>Element Display Stand - 37130</b> <i>(Requires worksurface mounting holes and cutout)</i>	✓
<b>Cove Power Module - 99044</b> <i>(Requires cutout)</i>	✓

# Product number breakdown

**37128 - MZ SN CM T2 1 0 2 B 0**

**Parent  
Number**

**Custom Worksurface Cutout:**

0 = None  
1 = Yes (*Contact Spectrum with details*)

**Cove Power Module Color:**

0 = No Cove Power Modules  
B = Black  
S = Silver

**Number of Cove Power Modules:**

0 = None  
1 = One Cove Power Module (centered)  
2 = Two Cove Power Modules (centered)

**Display Stand:**

0 = None  
1 = with Display Stand

**Worksurface Size:**

1 = 42"W x 60"L  
2 = 42"W x 72"L  
3 = 42"W x 96"L

**Leg Style:** (matches metal color)

T1 = T-Legs - 27"H  
T2 = T-Legs - 30"H  
T3 = T-Legs - 42"H  
P1 = Post legs - 27"H  
P2 = Post legs - 30"H

**Metal Color:**

B = Black  
CM = Champaign Metallic  
D = Dark Gray  
S = Silver Sparkle

	Laminate Color:†	Edgeband Color:
Standard Laminates	FM = Fusion Maple	FM = Fusion Maple
	IO = Indigo Organix	BK = Black (non-matching)
	CH = Wild Cherry	CH = Wild Cherry
Premium Laminates* (28-day lead time)	BK = Black	BK = Black
	BL = Bronze Legacy	BL = Bronze Legacy
	CK = Castle Oak	CK = Castle Oak
	CW = Colombian Walnut	CW = Colombian Walnut
	DZ = Desert Zephyr	DZ = Desert Zephyr
	EM = Empire Mahogany	EM = Empire Mahogany
	MO = Morro Zephyr	MO = Morro Zephyr
	MZ = Misted Zephyr	SN = Silver Northsea (non-matching)
	NP = Nepal Teak	NP = Nepal Teak
	NT = Natural Tigris	NT = Natural Tigris
	PM = Pewter Mesh	PM = Pewter Mesh
SM = Steel Mesh	SM = Steel Mesh	
TZ = Twilight Zephyr	TZ = Twilight Zephyr	
WF = White Fiesta	BK = Black (non-matching)	

\* Premium laminate colors require an additional 14 days of lead time.

† Laminate colors come with matching Edgeband color, with these exceptions: Indigo Organix Laminate comes with Black Edgeband, Misted Zephyr Laminate comes with Silver Northsea Edgeband, and White Fiesta Laminate comes with Black Edgeband.

T-Leg

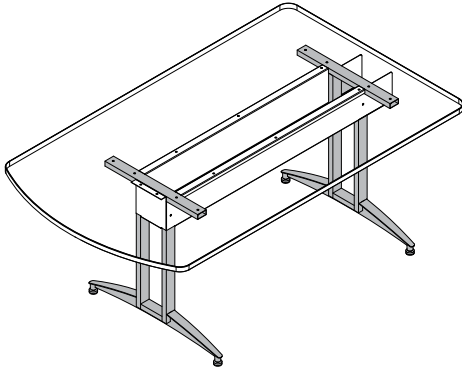

**ORDER CODE T1 = T-Legs - 27"H**

Elementary height

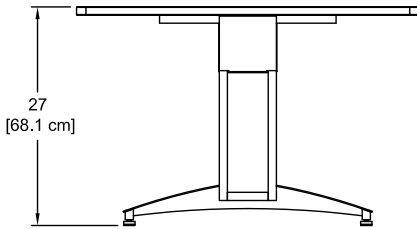

**ORDER CODE T2 = T-Legs - 30"H**

Adult height  
(used for ADA-compliance)

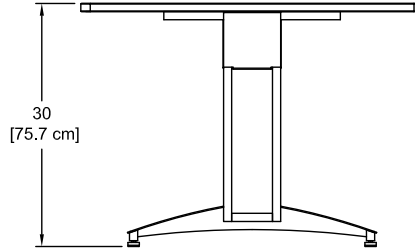

**ORDER CODE T3 = T-Legs - 42"H**

Standing height

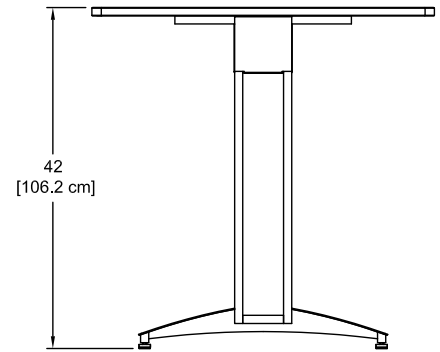

Corner Posts

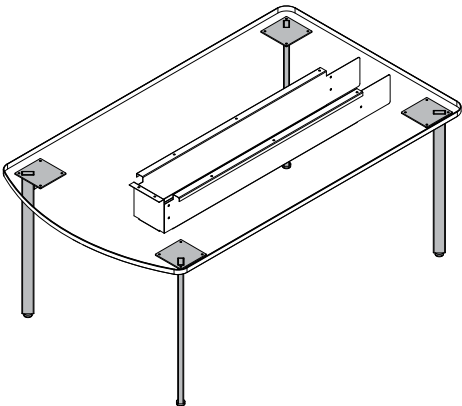

**ORDER CODE P1 = Post Legs - 27"H**

Elementary height

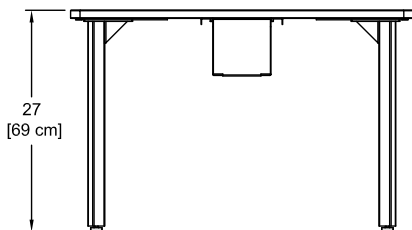

**ORDER CODE P2 = Post Legs - 30"H**

Adult height  
(used for ADA-compliance)

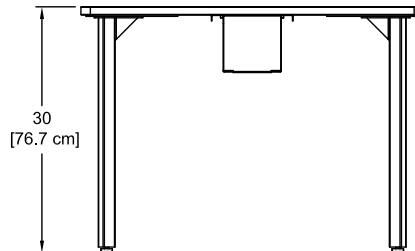

Note: 42"H Post Legs not available at this time.

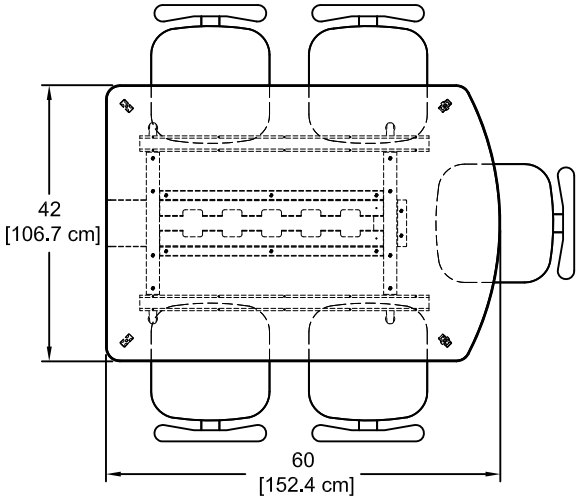

**ORDER CODE 1 = 42"W x 60"L**

- Seating for up to 5

Note: 60"L table not ADA-compliant

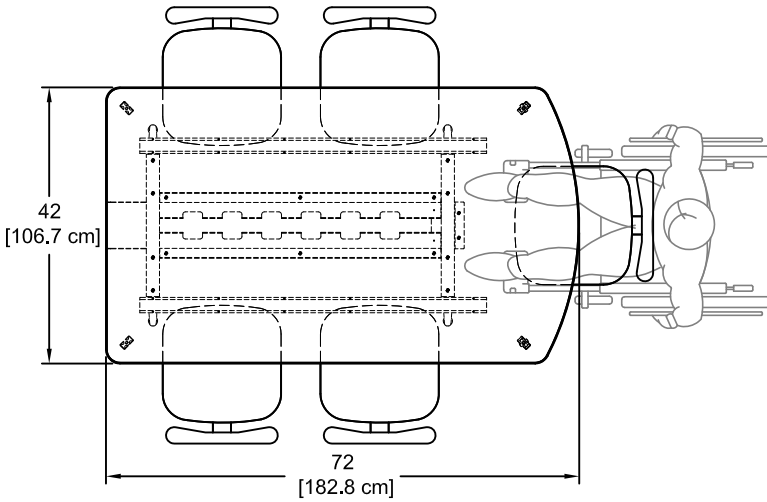

**ORDER CODE 2 = 42"W x 72"L**

- Seating for up to 5
- Provides 1 ADA-compliant seat at curved end
- For ADA use 30"H worksurface only

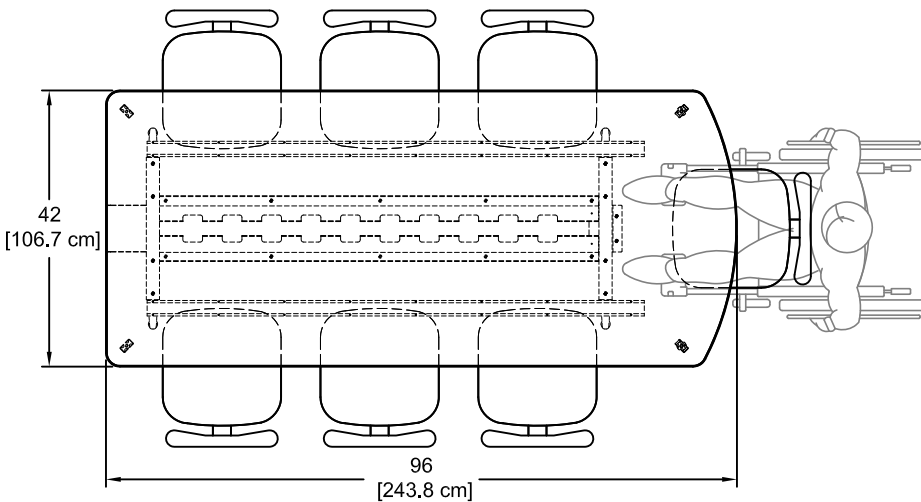

**ORDER CODE 3 = 42"W x 96"L**

- Seating for up to 7
- Provides 1 ADA-compliant seat at curved end
- For ADA use 30"H worksurface only



Note: If the Display Stand is used, distance between the nearest seat and the display should be maintained for viewing.

ORDER CODE 0 = None

ORDER CODE 1 = Display Stand

**Element Display Stand**

- Bolts directly to worksurface
- Integrated cable management routes and hides wires
- Adjustable (VESA-compatible) display mount
- Requires worksurface mounting holes and cutout

Monitor size range:	32"-55" [81.3 cm-139.7 cm] diagonal	
Weight capacity:	100 lb [45.4 kg]	
Vertical adjustment (worksurface-to-center)	• 23.5"H [59.7 cm]	(5 vertical positions in 2" increments)
	• 21.5"H [54.6 cm]	
	• 19.5"H [49.5 cm]	
	• 17.5"H [44.5 cm]	
	• 15.5"H [39.4 cm]	
Tilting	15° range	
Unit weight:	N/A	

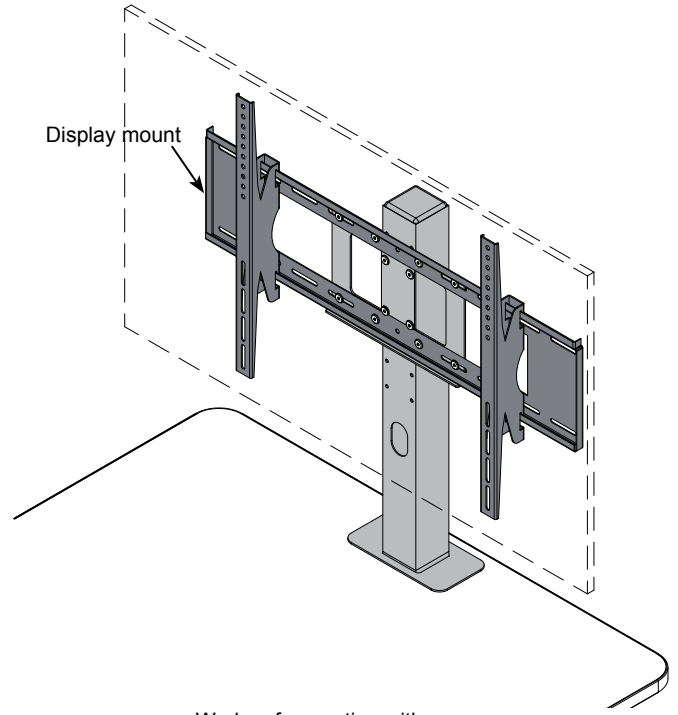

Worksurface option with mounting holes required- specify when ordering

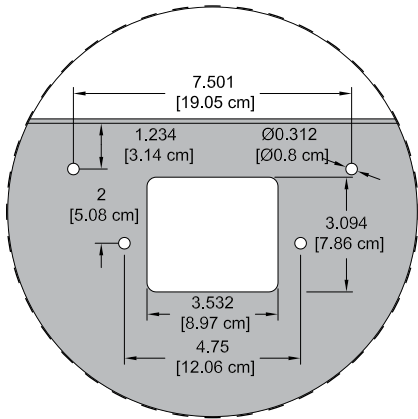

Mounting holes and cutouts needed on flat end of worksurface

5-vertical positions available  
(dimensions shown to center of mount)

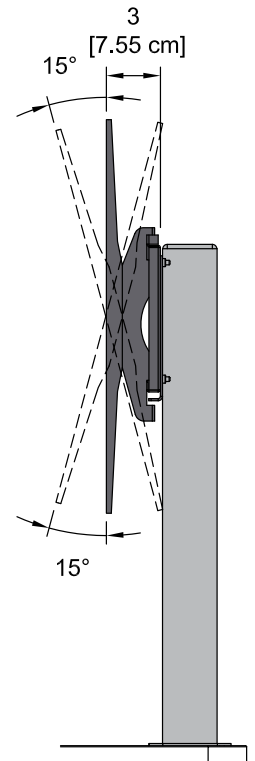
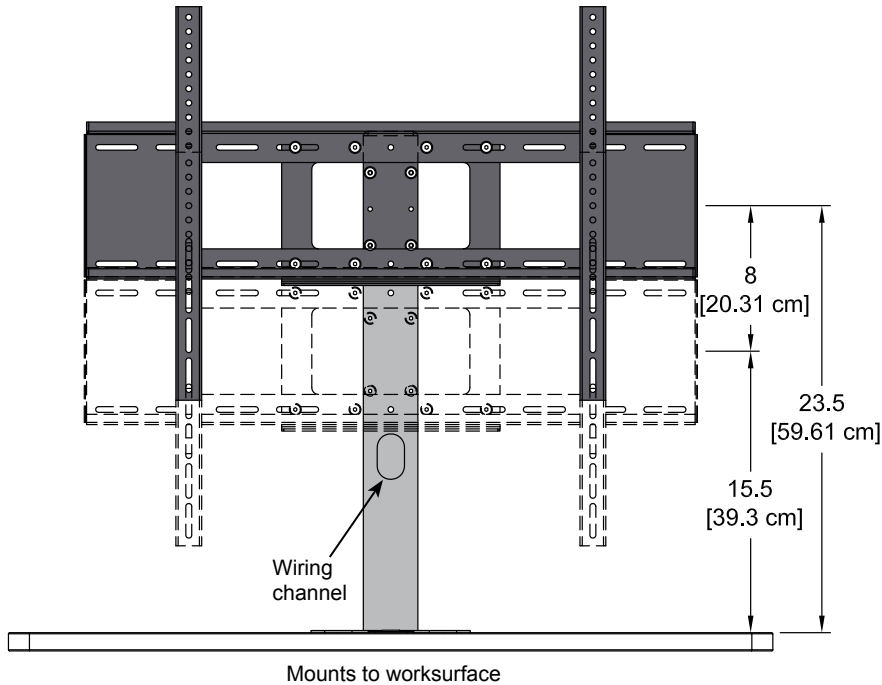

**Cove™ Power Module**

- Two power receptacles per module
- Two USB charge ports (not data-compatible)
- Thumbscrew clamps
- Requires worksurface cutout
- ETL listed
- Available in Black or Silver

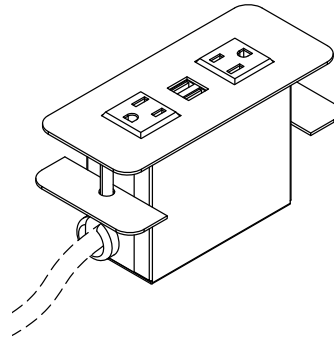

Cutout required:	5.25"W [13.3 cm] x 2"D [5.1 cm] (mounts to surface thicknesses up to 1.5")
Power cord:	9' [274 cm] with 90° flat plug with 45° rotation
Power receptacles:	12A, 120 VAC spill-resistant
USB charging ports:	2.1A (10.5W)
Dimensions:	6"W [15.2 cm] x 2.5"D [6.35 cm] x 3.18"H [8.1 cm]
Unit weight:	2.29 lb [1 kg]

**ORDER CODE 0 = None**

Standard Cove locations in worksurface

**ORDER CODE 1 = One Cove Module**

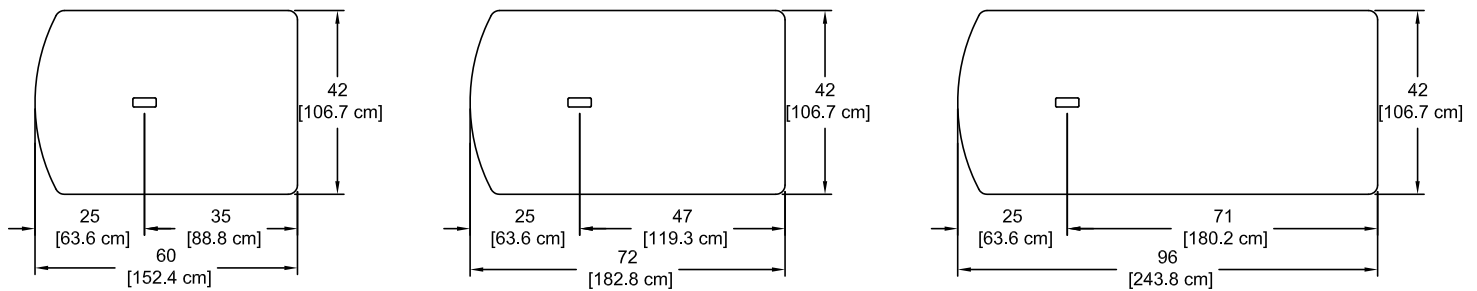

**ORDER CODE 2 = Two Cove Modules**

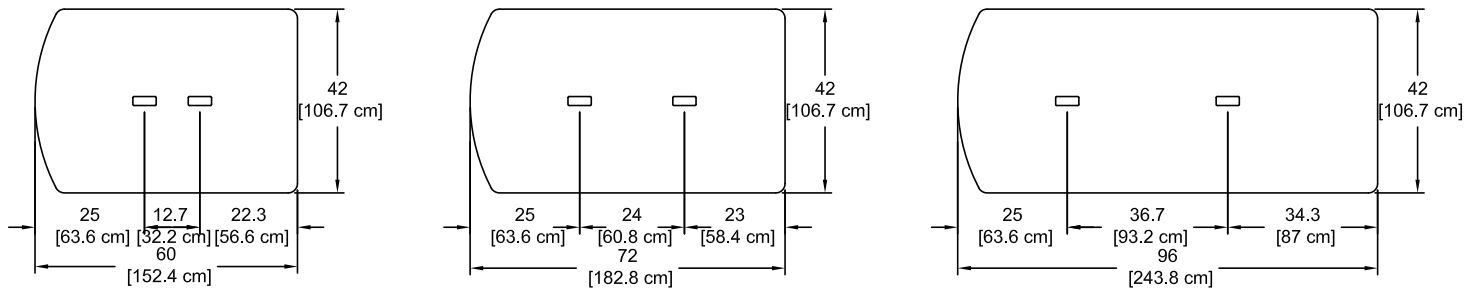

**Cove™ Power Module Colors**

**ORDER CODE 0 = None**

**ORDER CODE B = Black**



**ORDER CODE S = Silver**





60"L Table max cutout area:  
7"W x 34.1"L

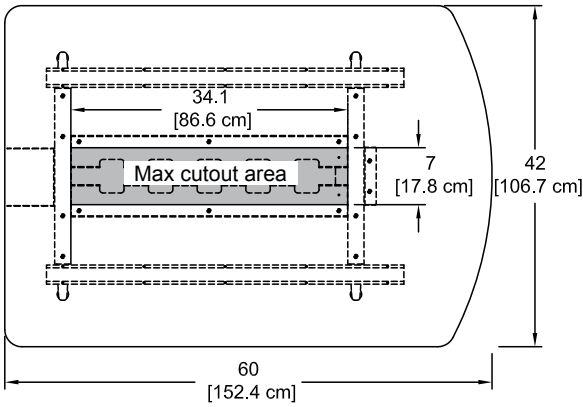

ORDER CODE 0 = None  
ORDER CODE 1 = Worksurface custom cutouts

**Custom cutouts by Spectrum**

- Contact Spectrum to specify cutout size(s) and location(s)
- See recommended cutout areas at left

Spectrum can provide cutouts exactly matching any commercially available data and electrical power outlet, but are only recommended within the maximum cutout areas shown. Cutouts made beyond this shaded area could interfere with the legs, wiring channel, or worksurface braces.

This table has been designed for many of the currently available surface-mount devices on the market.

72"L Table max cutout area:  
7"W x 42.9"L

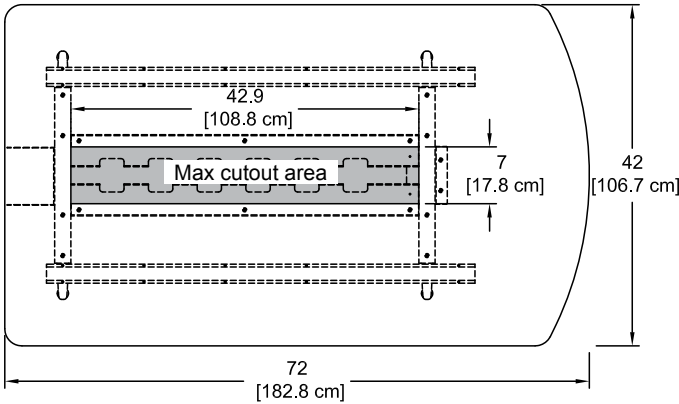

**\*When ordering a table with cutouts, specify complete details of the device(s) (brand, model number, cutout size, quantity, etc.) to the Spectrum sales rep when ordering.**

Cutouts in blank worksurfaces can be made by the customer after the table has been assembled, but are only recommended within the cutout areas shown.

96"L Table max cutout area:  
7"W x 66.9"L

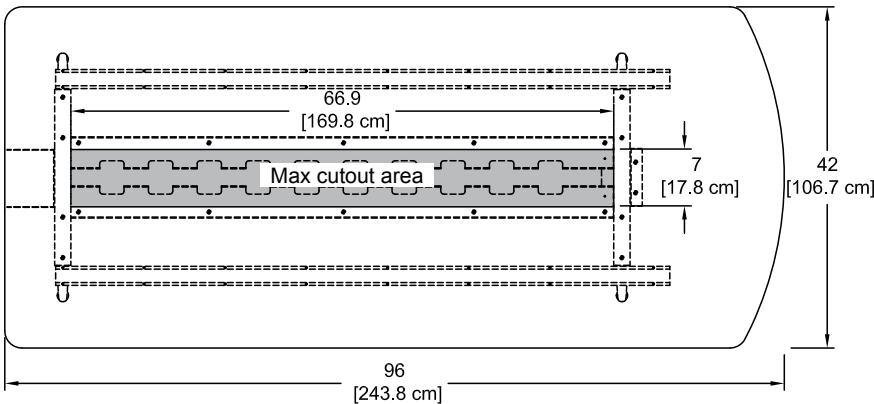

Note: Spectrum Industries, Inc, manufactures furniture that supports a wide variety of power and communication devices from a variety of manufacturers. This table is compatible with many Extron, Crestron, Altinex, AMX, and other devices. Spectrum does not resell these products; *please consult your electronic supplier* for the equipment that best suits your needs. Size specifications from the manufacturer can be used to verify the fit.



**Note: Some controllers and devices require additional space around the cutout for clamping under the worksurface. Please double check your device specifications to ensure adequate space around the cutout.**

InVision Element 60"L Table  
(shown with T-legs)

Note: 60"L table not ADA-compliant

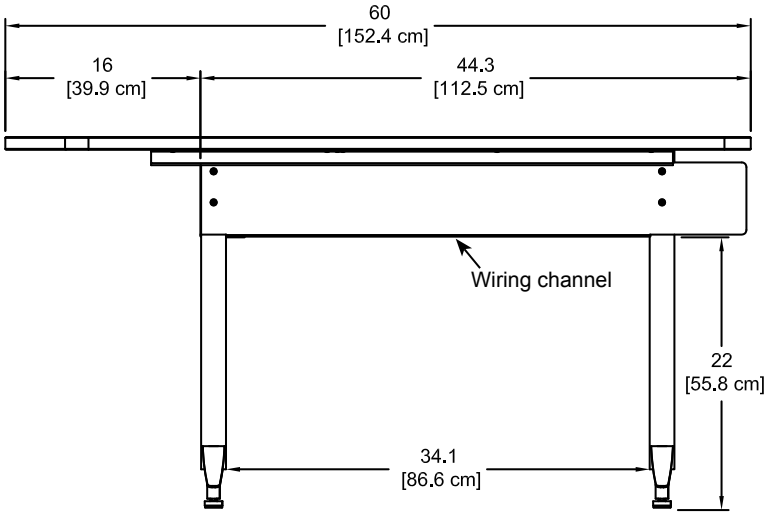
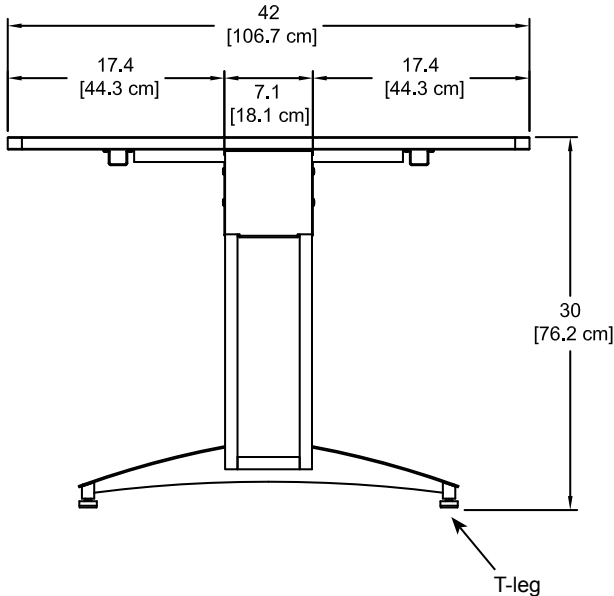
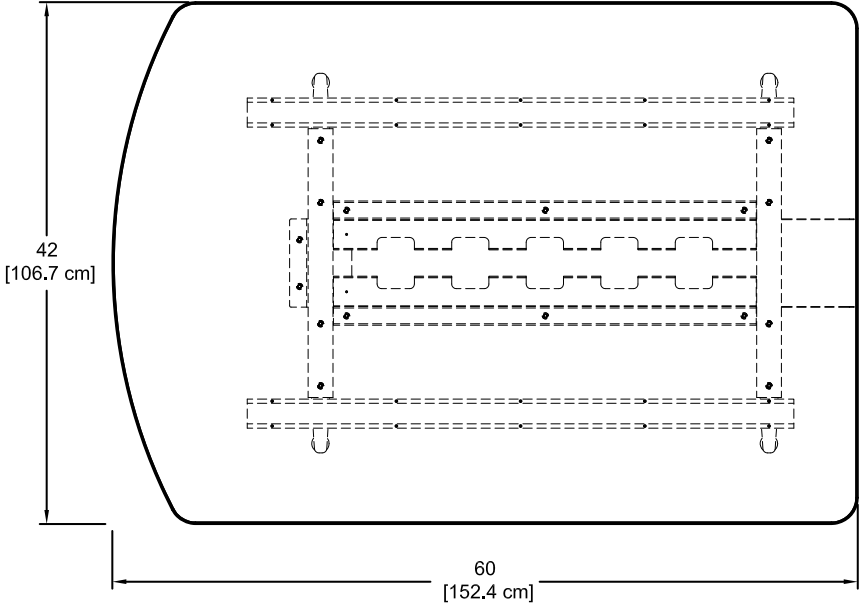

InVision Element 72"L Table  
(shown with T legs)

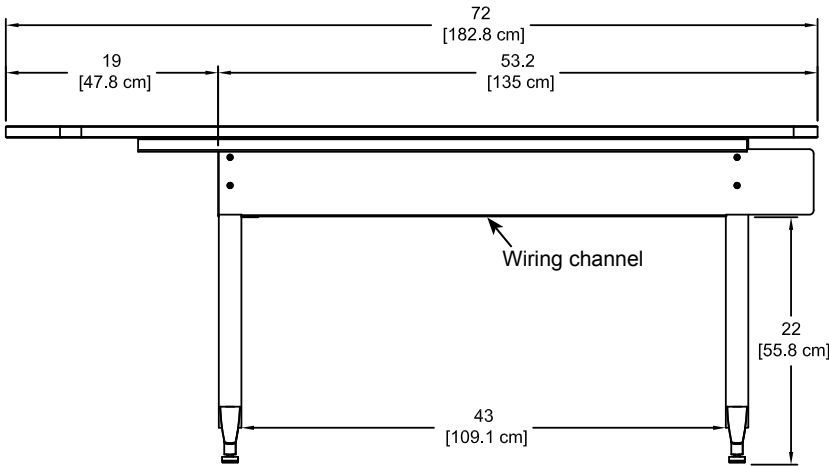
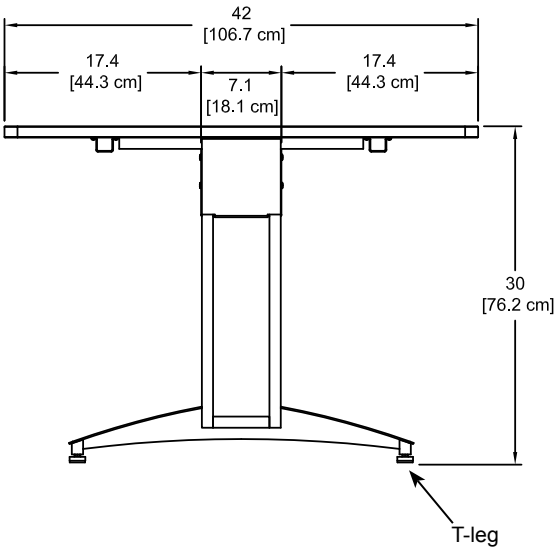
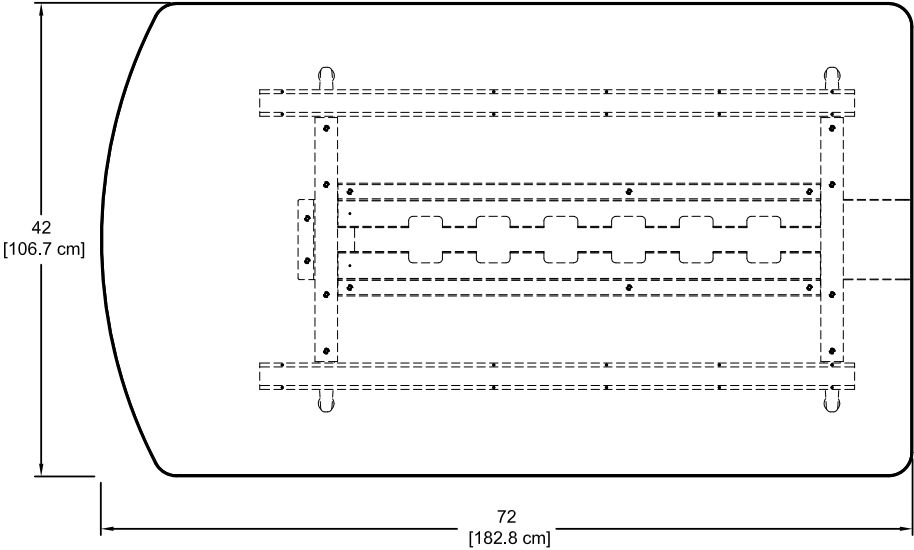
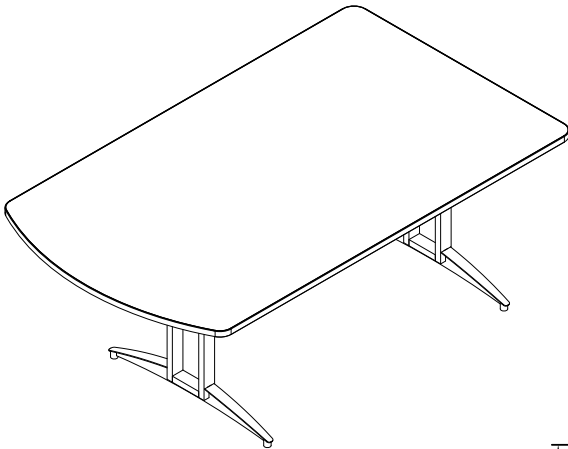

InVision Element 96"L Table  
(shown with Pedestal legs)

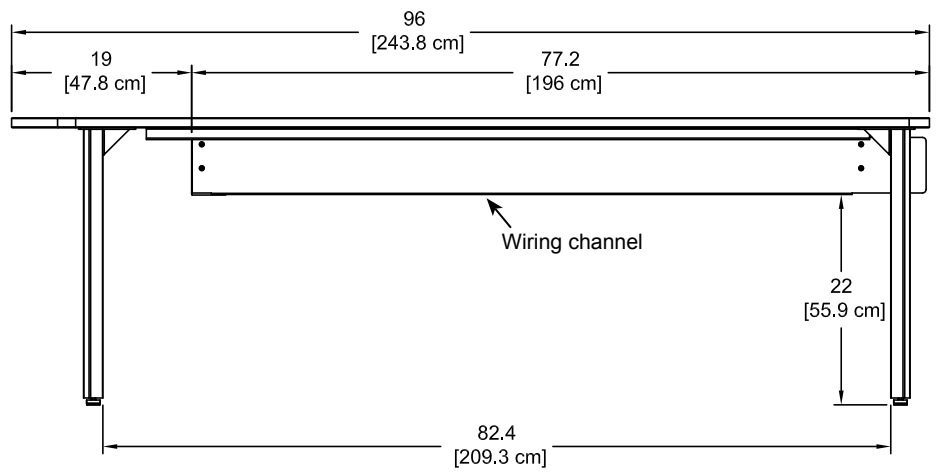
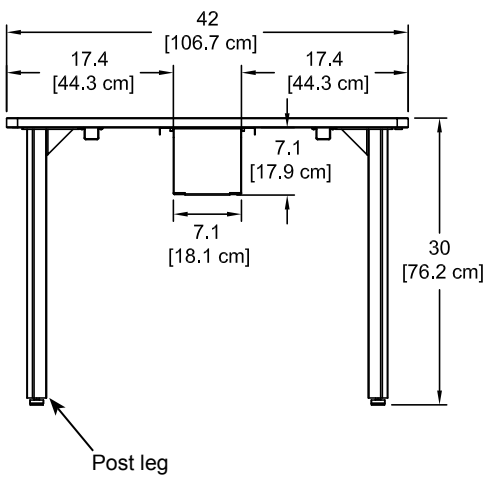
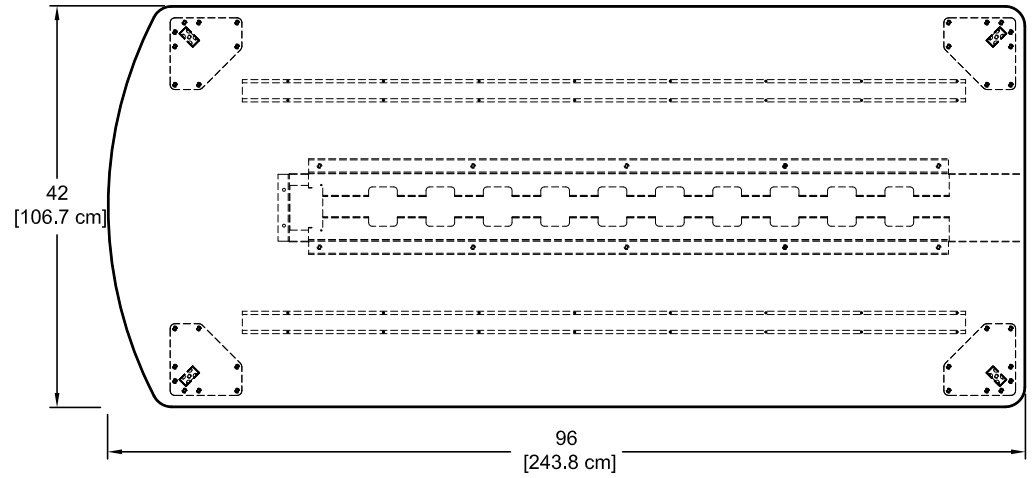
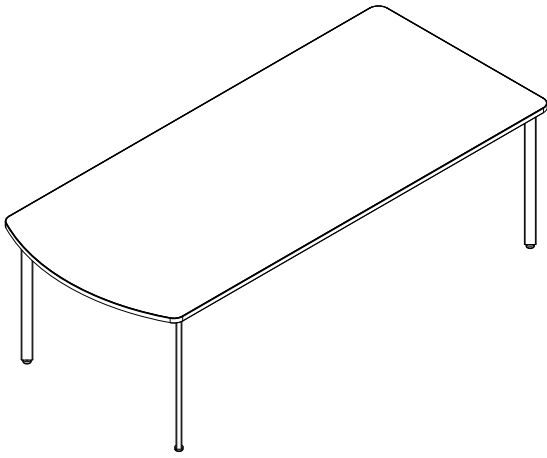

# Accessories (Available separately after initial configured purchase.)

## Element Display Stand - 37130

- Bolts directly to worksurface
- Integrated cable management routes and hides wires
- Adjustable (VESA-compatible) mount
- Requires worksurface mounting holes and cutout

Monitor size range:	32"-55" [81.3 cm-139.7 cm] diagonal
Weight capacity:	100 lb [45.4 kg]
Vertical adjustment (worksurface-to-center)	• 23.5"H [59.7 cm]
	• 21.5"H [54.6 cm]
	• 19.5"H [49.5 cm]
	• 17.5"H [44.5 cm]
	• 15.5"H [39.4 cm]
Tilting	15° range
Shipping weight:	35 lb [15.9 kg]

(5 vertical positions in 2" increments)

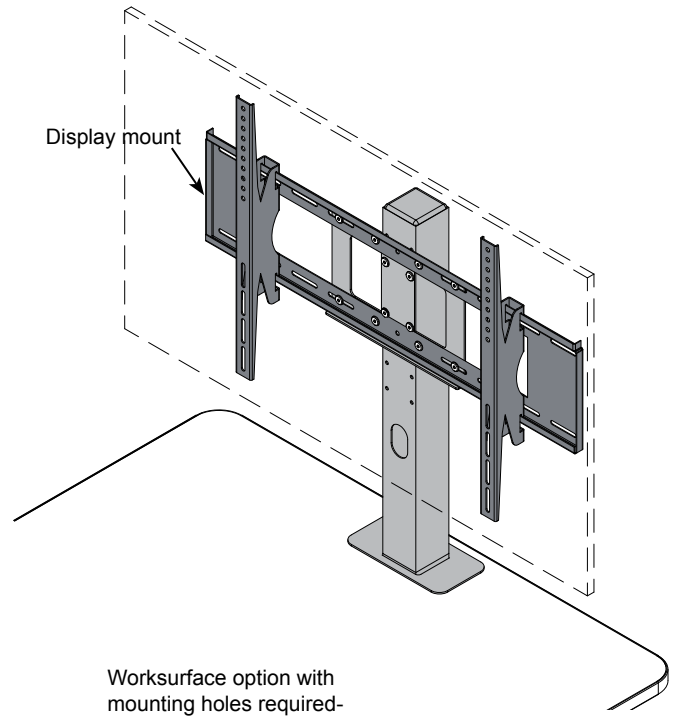

Worksurface option with mounting holes required- specify when ordering

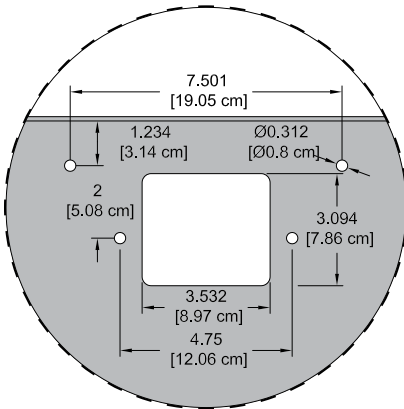

Mounting holes and cutouts needed on flat end of worksurface

## Cove Power Module - 99044

- Two power receptacles per module
- Two USB charge ports (not data-compatible)
- Thumbscrew clamps
- Requires worksurface cutout
- ETL listed
- Available in Black or Silver

Cutout required:	5.25"W [13.3 cm] x 2"D [5.1 cm] (mounts to surface thicknesses up to 1.5")
Power cord:	9' [274 cm] with 90° flat plug with 45° rotation
Power receptacles:	12A, 120 VAC spill-resistant
USB charging ports:	2.1A (10.5W)
Dimensions:	6"W [15.2 cm] x 2.5"D [6.35 cm] x 3.18"H [8.1 cm]
Unit weight:	2.29 lb [1 kg]

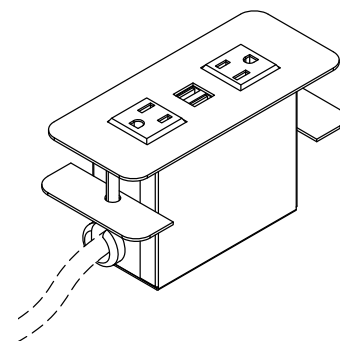

# Warranty

## WE WILL MAKE IT RIGHT FOR YOU!

Spectrum is committed to provide complete customer satisfaction. Each of our products is manufactured from the best materials available and each product is stringently monitored throughout the production process through our P.A.C.E. program (Product Assurance to meet Customer Expectations).

We expressly warrant that Spectrum products will be of good quality and workmanship and free from defect for the period set out in the warranty table below from the date of delivery. This warranty shall not apply to defects or damage resulting from misuse, abuse, neglect, improper care, modification or repair not authorized by Spectrum, or any other cause outside the control of Spectrum. Spectrum will, at its sole option, either repair or replace the defective product.

This warranty is exclusive; no other warranty, written or oral, is expressed or implied. This warranty is given by Spectrum to Buyer and to no other person or legal entity. No Spectrum dealer, distributor, agent or employee is authorized to make any modification or addition to this warranty.

**NOTWITHSTANDING ANYTHING TO THE CONTRARY, SPECTRUM WILL NOT UNDER ANY CIRCUMSTANCES BE LIABLE FOR INDIRECT OR LIQUIDATED DAMAGES, INCLUDING CONSEQUENTIAL, INCIDENTAL AND SPECIAL DAMAGES. IN NO EVENT SHALL SPECTRUM'S LIABILITY, WHETHER UNDER CONTRACT OR WARRANTY, IN TORT OR OTHERWISE, EXCEED THE PURCHASE PRICE RECEIVED BY SPECTRUM FOR THE PRODUCT AT ISSUE AND "RECALL ACTION" EXPENSES. SPECTRUM SHALL NOT BE SUBJECT TO ANY OTHER OBLIGATIONS OR LIABILITIES, WHETHER ARISING OUT OF BREACH OF CONTRACT, WARRANTY, TORT (INCLUDING NEGLIGENCE AND STRICT LIABILITY) OR OTHER THEORIES OF LAW, WITH RESPECT TO PRODUCTS SOLD OR SERVICES RENDERED BY SPECTRUM, OR ANY UNDERTAKINGS, ACTS OR OMISSIONS RELATING THERETO.**

Our Customer Service Department is ready to provide immediate attention to any questions, comments or concerns. They are available to answer your calls Monday through Friday from 7 am to 5 pm CST. In addition your product comments or concerns are welcome via e-mail at: [spectrum@spectrumfurniture.com](mailto:spectrum@spectrumfurniture.com).

Warranty Table

effective 1/1/2015

Item	Warranty Period
Adjustable Crank / Electric Desk Legs	• 1 Year
Flat Panel Desk Gas Cylinders	
Chairs <ul style="list-style-type: none"> <li>• Adjustable Height Chair Parts – including frames, gas cylinders, wood and plastic parts, control handles, casters</li> <li>• Adjustable Height Chair Upholstery</li> <li>• In-Stock Upholstery</li> <li>• Graded-In Fabrics and Customer Owned Material</li> </ul>	<ul style="list-style-type: none"> <li>• 7 Years</li> <li>• 2 Years</li> <li>• 2 Years</li> <li>• No Warranty</li> </ul>
Height Adjustable Columns and Lifts	• 1 Year
General Use Casters	
Electrical (including timers and LINAK actuators)	• 2 Years
Keyboard / Mouse Trays	• 1 Year
Flat Panel Monitor Arms <ul style="list-style-type: none"> <li>• Flat Panel Monitor Arm – General Parts</li> <li>• Flat Panel Monitor Arm – Gas Cylinders</li> </ul>	<ul style="list-style-type: none"> <li>• 5 Years</li> <li>• 2 Years</li> </ul>
Desks and Lecterns <ul style="list-style-type: none"> <li>• Computer Desk Chassis</li> <li>• Cart Chassis</li> <li>• Lectern Chassis</li> </ul>	• 10 Years



INDOOR ADVANTAGE GOLD  
FURNITURE

