

GW INSTEK

POWER SUPPLIES CATALOG



www.gwinstek.com

World-Class Quality and Performance

Affordable Price

A Wide Range of Selections

Originally known and founded in 1975 as Good Will Instrument, GW Instek is the first professional manufacturer in Taiwan specializing in electrical test and measurement instruments. GW Instek began as a manufacturer of power supplies and quickly expanded into developing high precision electronic test and measurement instruments. After 44 years in the test and measurement industry, GW Instek has grown to become one of the most recognized manufacturers of instruments in the world. Today, GW Instek has more than 300 items ranging from oscilloscopes, spectrum analyzers, signal sources, DC power supplies, AC power sources, digital meters, LCR meters, other specific application meters to video surveillance systems.

Think of the word "innovation" and it's easy to think of R&D, new inventions, faster processing and groundbreaking technologies. At GW Instek, we focus on another type of innovation that is based on flexibility, manageability and efficient performance in real-world test applications. We call this "customer-focused" innovation and we strongly believe in it. By listening to our customers around the world, we are able to anticipate their needs and respond quickly to emerging trends. So when one of our customers introduces an exciting new technology, GW Instek is ready to test it.

Whether our customers are designing products with the ability to change people's lives, educating and training the engineers of tomorrow, or discovering new technologies that solve complex problems, GW Instek can be trusted to perform reliably and accurately in even the most demanding test environments. How can we be sure? We have the numbers to back it up. Actually, we have just one : 44. That's the number of in-house quality and performance verification tests each GW Instek product must pass before it leaves our facilities. This thorough process starts with environmental, safety and durability testing in the product design phase, through to burn-in and shipping tests ahead of final inspection and packing. Furthermore, our two manufacturing facilities in Taiwan and China all adhere to ISO quality and environmental management standards, as well as European CE safety regulations. That's why GW Instek products can be trusted to test.

At GW Instek, quality is reflected not in higher cost, but in greater value. We pride ourselves on the quality, reliability and affordability of our test and measurement instruments. With each of our products often in use for decades, it's not hard to understand the importance of measuring a product's value not by price, but by lifetime cost. This importance is deep-rooted to us; we have consistently produced products with some of the industry's lowest total cost per ownership. Reducing the total cost per ownership of our products allows us to provide exceptional value, reliability and performance with leading service and support over the lifetime of a product. That's why year after year, GW Instek can be trusted to perform reliably.

The industries we serve are as diverse as they are specialized. Our experience and expertise allow us to deliver high-performance test solutions that address the unique requirements of each client. GW Instek provides customized solutions that are backed by reliable products, comprehensive after-sales support, warranty, calibration services, and one of the industry's lowest Total Cost per Ownership.

GW INSTEK

Simply Reliable

SINCE
1975



44 Years of Reputation
& Trust

We take prides in creating more than 44 years of satisfied customer experiences throughout the world. Today, GW Instek is considered the most Reliable Brand for professional measurement instruments with supreme quality and the **lowest TCO - Total Cost per Ownership**.

We invite you to be part of GW Instek success story and help perpetuate this value.

DURABLE



Uncompromised
Durability

With an overriding commitment to provide highly durable products, GW Instek is your most **Reliable choice** when it comes to selecting the best measurement instruments with the **lowest TCO - Total Cost per Ownership**. Highly durable products mean long product lifetime capable of reducing operation & maintenance costs. This is definitely what you need to consider before investing.

TRUST &
PROMISE



Your Most Trustworthy
Partner

Being your most trustworthy and **Reliable Partner**, GW Instek promises to proactively provide insightful business solutions and products with the **lowest TCO - Total Cost per Ownership**, assisting your business to thrive in the highly competitive world. From feasibility evaluation, product selection, solution adaptation to timely after-sales service, we are dedicated to serving each individual customer and making your professional life easier than ever.

Milestones

- 
- 1975 Good Will Instrument Co., Ltd was established as a Power Supply manufacturer.
 - 1983 The Kaohsiung branch was established.
 - 1985 The Taichung branch was established.
 - 1989 Good Will Southeast Asia (Malaysia) was established.
 - 1991 Instek America Corp. was established.
 - 1993 Taiwan headquarters was ISO-9002 certified.
Granted the National Small and Medium Enterprise Award.
Granted the Industrial Technology Advancement Award of Distinction.
 - 1996 Good Will Southeast Asia (Malaysia) was ISO-9002 certified.
 - 1998 Taiwan headquarters was ISO-9001 certified.
 - 1999 Taiwan headquarters was ISO-14001 Environmental Management certified.
Good Will Instrument Co., Ltd. delivered Initial Public Offer on Taiwan's Over-The-Counter Security Exchange (OTC).
 - 2000 The CNLA Electricity Calibration Laboratory certification was granted.
Good Will Instrument was went public on the Taiwan Stock Exchange.
 - 2001 Good Will Instrument Suzhou was established.
 - 2002 Taiwan headquarters was ISO-9001 : 2000 certified.
 - 2003 Suzhou subsidiary was ISO-9001 : 2000 certified.
 - 2004 Instek Electronics Shanghai was established.
 - 2005 Global operational headquarters was established in Taiwan.
The brand new CIS (Corporate Identity System) was introduced.
 - 2006 Instek Japan Corporation was established.
 - 2007 Good Will Instrument Korea was established.
 - 2009 The Group Quality Award of Business Excellence Performance Model from the Chinese Society for Quality was granted.
 - 2010 Marketing office was set up in India.
 - 2011 GW Instek won Taiwan Excellence Award for GDS-1000-U Series, AFG-3000 Series, PEL-2000 Series and GDM-8261.
 - 2012 GW Instek won Technology Innovation Award for GDS-3000 Series and GSP-930.
Acquired Japan TEXIO technology corporation.
 - 2013 Instek Digital was merged to become a member of GW Instek business group.
GW Instek cooperated with Hitachi and EMIC to establish GW Alliance in Suzhou, China.
GW Instek won Technology Innovation Award for PPH-1503 and AFG-2225.
 - 2014 GW Instek won Technology Innovation Award (Gold) for GDS-300 full touch screen oscilloscope.
European subsidiary was established in the Netherlands.
 - 2015 GW Instek won Taiwan Excellence Award for GDS-300/200 Series and PEL-3000 Series.
 - 2016 GW Instek won Taiwan Excellence Award for GDS-2000E Series and GSP-9330.
 - 2017 GW Instek won Taiwan Excellence Award for C-1100 and GPM-8213.
 - 2018 GW Instek won Taiwan Excellence Award for C-1200 and GDM-906X Series.
 - 2019 GW Instek INDIA LLP was established.

POWER SUPPLIES



Global Network



Suzhou Plant

Headquarters & Plant

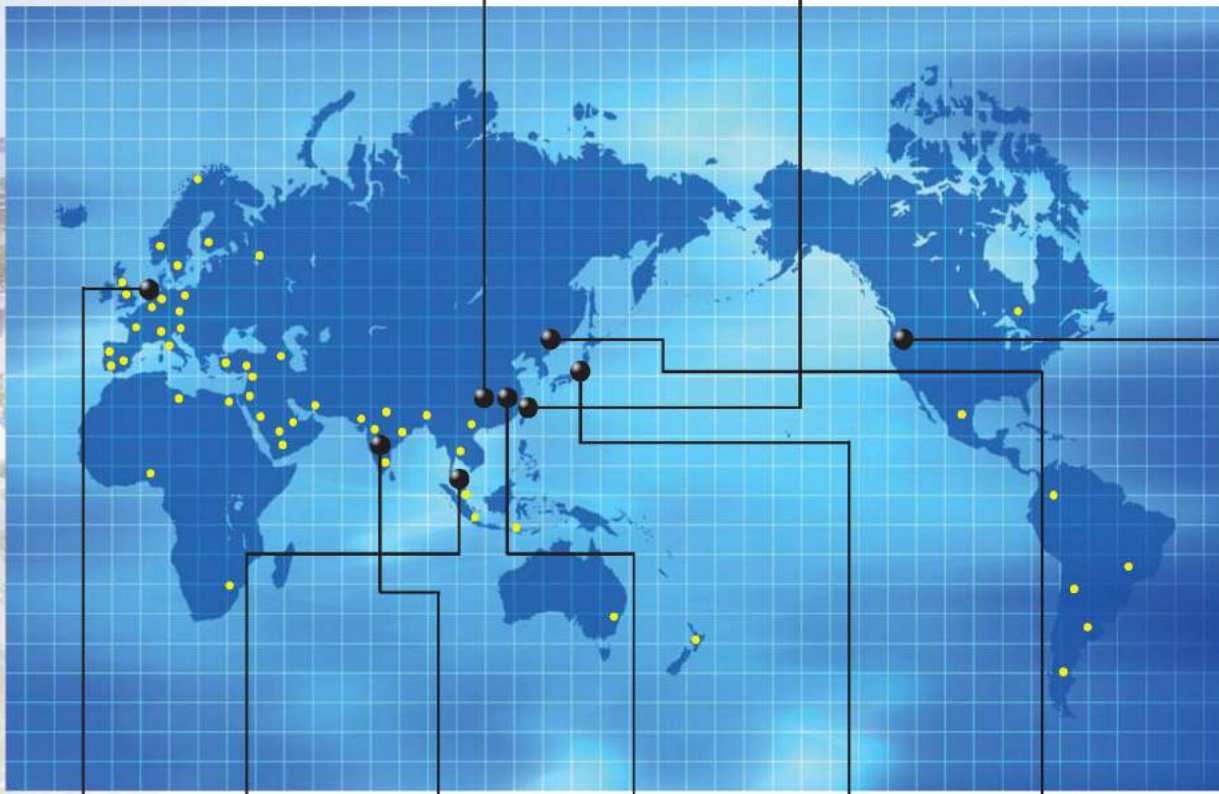

Europe Subsidiary

Malaysia Subsidiary

India Subsidiary

China Subsidiary

Japan Subsidiary

Korea Subsidiary

U.S.A. Subsidiary



Comprehensive Electronic Measurement Solutions

Becoming the highest customer value TMI products and services provider in the global market is the vision of GW Instek and this vision, in the meantime, has always been the managerial objective ever since the establishment of the company. Over the span of 44 years' continuous refinement and progression, GW Instek began as a manufacturer of the earliest models of analog power supplies and has rapidly expanded to provide users of nowadays with more than 300 products consisting of 500 MHz Digital Oscilloscope, High-Power D.C. Power Supplies, High-Power D.C. Electronic Loads, 3 GHz Spectrum Analyzer, 80 MHz /25 MHz Arbitrary Waveform Generator, Programmable D.C. Power Supplies, A.C.(D.C.) Power Source, 6 1/2 Digit Dual Measurement Multi-Meter, 10 MHz High Frequency LCR Meter, and All-in-one electronic Safety Testers, etc. so as to not only fully satisfy users' demands in the process of product development, verification, production, test and quality assurance, but also meet comprehensive and complete equipment requirements for a wide extent of tests, including military industry and scientific research.

Manufacturers of various industrial electronic and consumer electronic products are seeking ways to reduce production costs down in order to keep up with the market competitiveness while facing the dramatic changes of the global electronic industry. The design of the new generation programmable switching power supply satisfies the recharging test applications for high power batteries. The built-in Sink Current Circuit not only effectively expedites the voltage fall time during output off mode, but also prevents reverse voltage from happening so as to effectively protect the power supply. Reverse voltage occurs when external voltage is higher than the internal voltage of the power supply once the external unit is fully charged. The new generation Programmable Switching D.C. Power Supply adopts Interleaved PFC (Power Factor Correction Circuit) and DC/DC module circuit to effectively reduce high frequency ripples during output on and to meet the requirements of low ripple applications.

In recent years, we have successfully constructed power measurement functions on Digital Storage Oscilloscopes. Via the combination of Power Management App and internal measurement hardware module, we have simplified the required power measurement equipment. With respect to AC/DC Power Source products, we have met the international regulation (Energy Star) for low standby mode power consumption measurement requirements. To meet the requirements of all-in-one equipment, we have combined A.C. power source with power meter measurement functions. All-in-one equipment provides convenience for measurement and system integration, and most importantly, it strengthens the market competitiveness and dramatically enhances functionality. In the future, we will devote our efforts to strengthening single instrument's performance, including A. user interface; B. measurement items; C. measurement accuracy; and D. measurement speed to meet the recent industrial requirements from power supply manufacturing, automotive electronics, and green energy industry.

More than a simple instrument provider, GW Instek, with scores of practically applied experiences in instruments, is now offering this specific catalog for power supplies to better provide users with a conceptually systematic combination, further assisting our customers achieving the purposes of both products applications and measurements.

Uncompromised Durability
with Highest Quality Standard



Vehicle Power Supply Simulation and Windshield Wiper Motor Application

With the popularity of technology and the evolution of electronic products, the electronic components used in today's cars are also becoming more diverse. Power windows, power mirrors, parking sensors, windshield wiper motors, etc., use batteries as a source of power. However, during the running of the vehicle, the supplied power supply is not constant. In order to ensure that the electronic components of the vehicle can still work normally under the condition of power supply fluctuation, the power supply can be used to simulate the abnormal output that may be generated by the battery to perform functional tests on the vehicle electronic products that is conducive to screen out defective components and products during the product testing phase.

Take the windshield wiper motor as an example. The processes of the windshield wiper motor operation generally include: 1 The rotation of the motor drives the back and forth of the windshield wiper. 2 Each time the windshield wiper is stationary, the windshield wiper must stay at the edge of the viewing angle without obstructing the driver's line of sight. 3 When the two windshield wipers are brushed at the same time, there should be no collision. The motor operating voltage range is DC: 10V ~ 15V, and its maximum operating current will be different at low speed or high speed. In order to verify that the varying power supply voltage does not affect the operation of the windshield wiper motor, the DC power supply can be used directly to generate a series of varying power outputs to the windshield wiper motor. The following figure shows the variable power supply for testing the windshield wiper motor. As follows, after a stable DC power supply, an unstable power supply output is provided to the windshield wiper motor and its operation is evaluated.

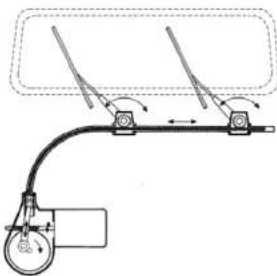

Schematic Windshield Wiper Motor

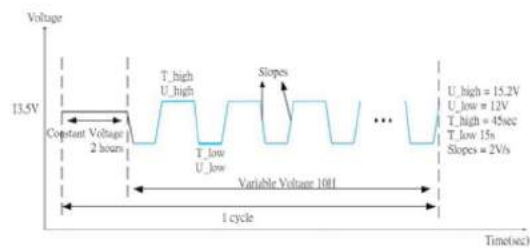

PSW-Series Test Scripts Function

The PSW Test Script function can be used to plan a continuous set of voltage changes. Users can edit the output voltage, current and execution time separately. For individual steps, OVP, OCP, voltage rise/fall slope or current rise/fall slope, and constant voltage or constant current priority mode can be set.

By editing the required power change output (eg. 200 cycles) on the Excel table, then loading the Excel table into the PSW stand-alone unit to perform the stand-alone automated execution, users can perform the above power output to verify the operation of the windshield wiper motor by a stand-alone unit.

Step	Point	Output	Time(sec)	Voltage (V)	Current (A)	OVP(V)	OCP(A)	Bleeder	TV Mode	Vsr up(V/s)	Vsr down(V/s)	Isr up(A/s)	Isr down(A/s)	IR(ohm)	Beeper	Sense Ave.	Jump to	Jump Cnt.
1	start	On	7200	13.5	6	MAX	MIN	ON	CVHS	MAX	MAX	MAX	MAX					
2		On	1.5	12	6	MAX	MIN	ON	CVHS	MAX	MAX	2	MAX	MAX				
3		On	1.5	12	4	MAX	MIN	ON	CVHS	MAX	MAX	MAX	MAX					
4		On	1.6	15.2	6	MAX	MIN	ON	CVHS	2	MAX	MAX	MAX	MAX				
5		On	4.5	15.2	6	MAX	MIN	ON	CVHS	MAX	MAX	MAX	MAX	MAX				
6		On	1.6	12	6	MAX	MIN	ON	CVHS	MAX	MAX	2	MAX	MAX			3	569
7	end	On	1	13.5	6	MAX	MIN	ON	CVHS	MAX	MAX	MAX	MAX				1	199
8																		
9																		
10																		
11																		
12																		

With the Test Script function provided by GW Instek, it is very easy to perform the complex power output control under Excel editing. For users, there is no need to install an additional software, and there is no cumbersome step. Hence, using the PSW to perform complex sequential power outputs is a simple task.

PSW30-36 Internal resistance setting range : 0.000Ω~0.833Ω



PSW Built-in Resistance Variable Function Simulating Battery Output Resistance and Wire Harness

In addition, for the simulation of the real power supply situation at the factory, PSW can simulate the battery to supply power to the windshield wiper motor and activate PSW's built-in resistance variable function to set the built-in resistance value to simulate the battery output resistance and Wire Harness's resistance. By so doing, PSW can verify the output characteristics of the windshield wiper motor before it is installed in the car.

Car DC-DC Converter Effectiveness Evaluation

The output voltage of common electric vehicle batteries is high voltage ranging from 200V to 400V. In order to drive conventional 12V vehicle electronic devices, e.g. instrument panel display, lighting, electronic control unit (ECU), etc., the high-voltage output battery often transforms the high voltage of the battery into a 12V output through the step-down DC-DC converter. The step-down DC-DC converter is generally required to provide a stable voltage output, even if its input source cannot be maintained at a stable output. Therefore, the output characteristic test of the step-down DC-DC converter is very important. Generally, a high-voltage power supply can be used to simulate the input of the step-down DC-DC converter, and a large-capacity electronic load can be used to simulate vehicle electronic devices to test the output capability of the step-down DC-DC converter.

The PSU high-voltage model includes a voltage output range from 200V to 400V, and it can achieve a power output of 6KW through parallel connection, which can be used to simulate the battery output of the electric vehicle. The PEL-3955 can simulate the power consumption of a 12V automotive electronic device and output the monitored current to the oscilloscope for observation.

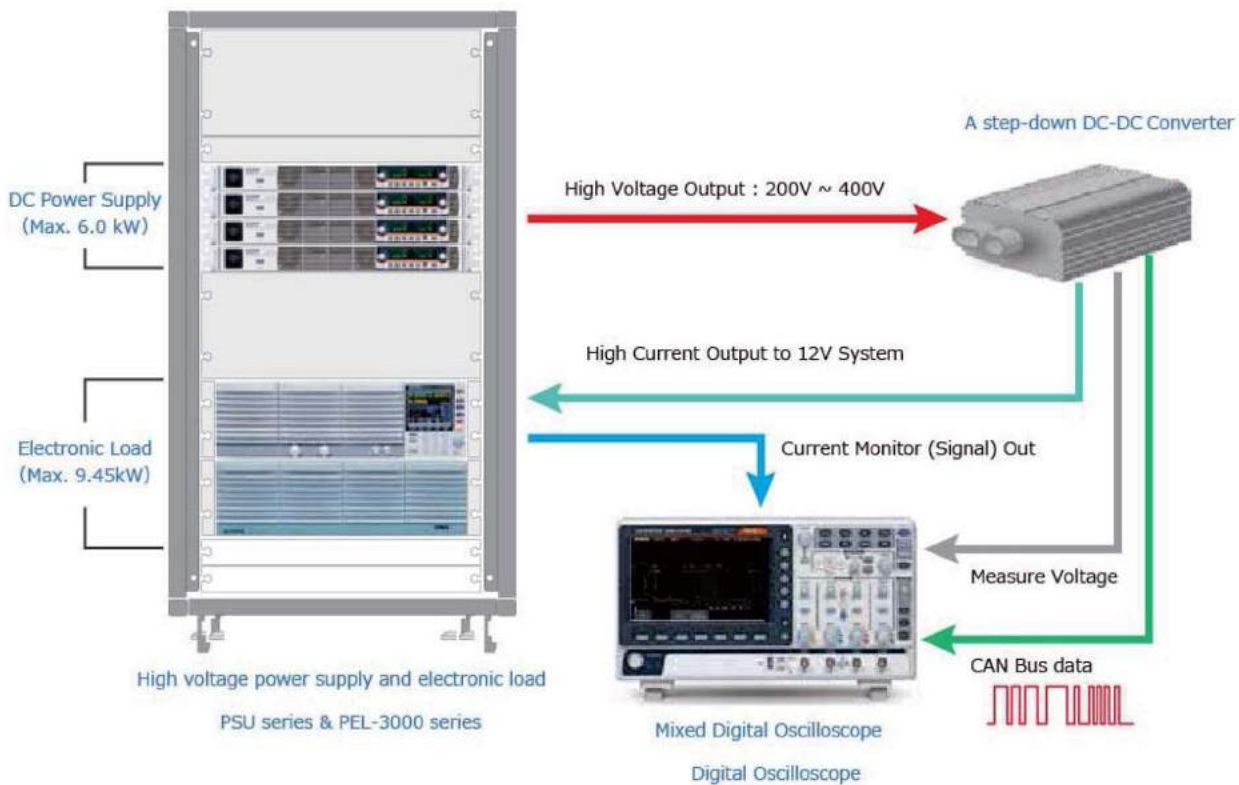

PSU can set the sequential power output to generate a set of varying power outputs to the step-down DC-DC converter to evaluate the Line Regulation characteristics of the step-down DC-DC converter. In addition, setting the PEL-3955 to operate under the Dynamic mode, users can evaluate the transient recovery time and load regulation of the step-down DC-DC converter. According to the load waveform of the vehicle device, users can edit the PEL-3955's sequence function to generate the load waveform so as to verify the output capability of the step-down DC-DC converter.

The Reliability Test of Vehicle Horn

Vehicle Horn is often used in transportation such as cars, motorcycles, trucks, buses, trains, etc. During the travel of the vehicle, the Vehicle Horn can sound to warn other vehicles or draw attention to avoid danger. If the sound intensity of the Vehicle Horn is to be measured during the burn-in test, the fanless PFR series power supply best meets such test requirements. The PFR series fanless design structure can quietly output power to the Vehicle Horn and the sequential output power function Test Script allows users to edit the burn-in test process.

PFR-Series

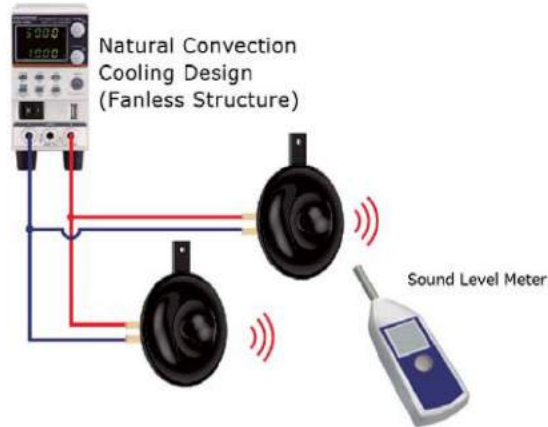

A Sound Measurement of the Vehicle Horn

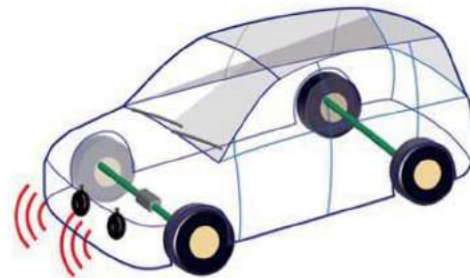

A Car Equipped Vehicle Horn

Edited Test Script to PFR for Burn-in Test :

	A	B	C	D	E	F
1	memo	Hone test				
2	DisplayItem	VI				
3	CycleItem	Number	Start Step	End step		
4	Cycle	50000	2	3		
5	Step	Point	Output	Time(sec)	Voltage(V)	Current(A)
6	1	Start	Off	0.5	0	7
7	2		On	1	13	7
8	3		Off	4	13	7
9	4	End	Off	0.5	0	7
10						

Voltage : 13.0V

Current : 7.0A

Cycle : 50,000



PFR-Series

PFR Output Waveform for Burn-in Test :

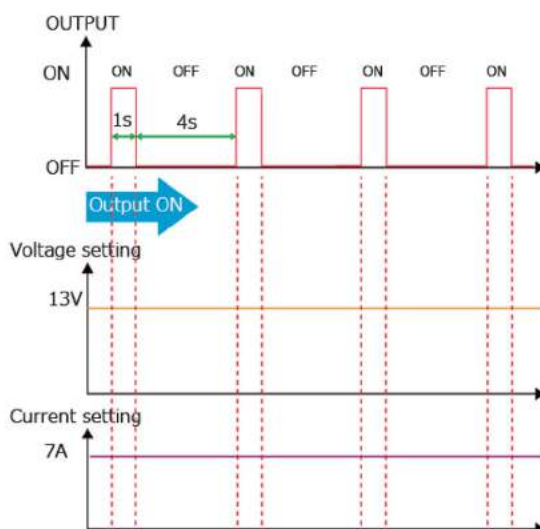

LED Test Application

The light-emitting diode is a special diode. Its main structure is the same as that of a common diode. It is composed of a P-type and N-type semiconductor. It uses the different characteristics of the forward bias and reverse bias of the P-N junction to turn on or off. The voltage-current output relationship when applying a forward bias to a light-emitting diode (see Fig. 1.). When the applied forward bias is greater than the V_f value, the diode begins to emit light, and the luminosity of the LED is directly related to the magnitude of the driving current. The larger the current value, the stronger the illuminance. If the current value is too large and exceeds the rated current value, the LED will have permanent damage.

In the actual test process of the LED, the conventional power supply output is usually under the CV mode. When the forward bias voltage is greater than the V_f value of the LED, the LED may be given a surge current due to the instantaneous conduction. If this surge current exceeds the rated maximum current value, it may cause permanent damage to the LED.

The CC priority mode function designed by GW Instek on the power supplies allows the output of the power supply to run under the CC mode preferentially to avoid the surge current and prevent the LED from being damaged by the surge current during the LED test.

Note: PFR series, PLR series, PSW series, PSU series, PSB-1000 series support the CC priority mode function.

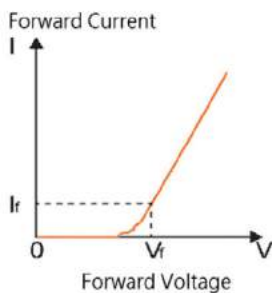
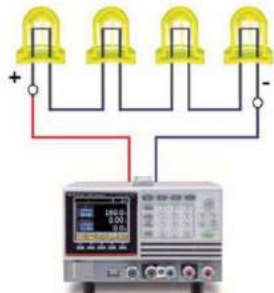
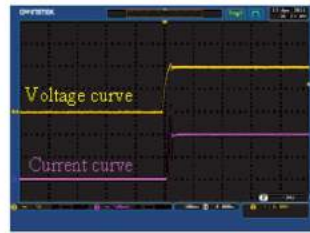

Fig. 1.: V-I Characteristic Chart



Illustrations of PSB-1000 Connecting to LEDs



Under the Conventional C.V Mode, Inrush Current and Surge Voltage Appeared at Forward Voltage (V_f) of LED

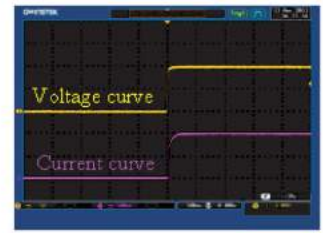

Under C.C Priority Mode, Inrush and Surge Voltage are Effectively Restrained

Precise Control RF Attenuator with PEL-3021

PSW+PEL-3000 can form a low-cost, high-accuracy, high-resolution current output controller. Typical RF Attenuators often use PIN diodes as microwave switches and microwave attenuators. In high frequency applications, providing a PIN diode forward bias or reverse bias can control whether the high frequency signal RFin can be output to RFout.

As shown in the figure below, the DC Block component is nearly short-circuited for the high-frequency RFin signal, so the RFin signal can pass directly. The RF Block is nearly open-circuited for the high-frequency RFin signal, so that the RFin signal is output to the RFout via the DC Block and the PIN diode. Precise control of the DC current flowing through the PIN diode allows precise determination of how much RFin signal is attenuated and then be output to RFout.

The PEL-3021 has a high resolution setting of 0.01mA. It can increase the DC control current by the increment of 10uA to observe the relationship between the measurement signal RFin and RFout, and further draw the attenuation curve of the RF Attenuator. The RF Attenuator's automated measurement can automatically increase the load current value using the PEL-3021's Sequence Function and simultaneously trigger the external device to conduct measurement using the Trigger Output function.

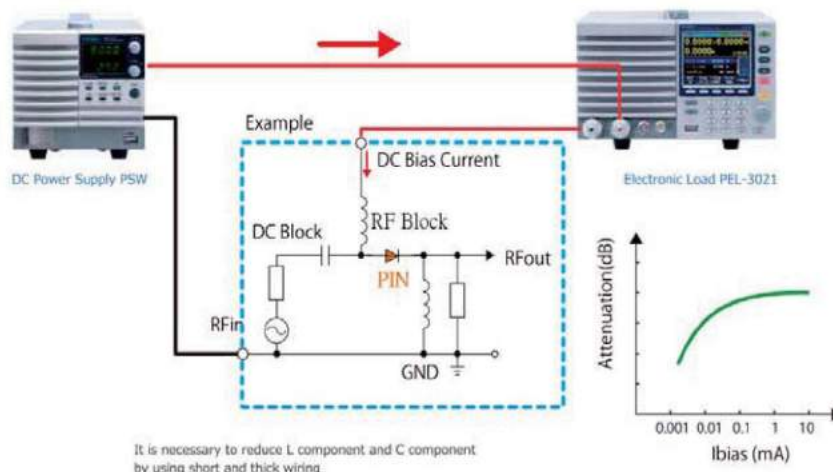

Bias Current vs. Attenuations

Reliability Test for Relay Using GW PSW Power Supply and PEL-3111 E. Load

How do you conduct relay connection point (N.O. / N.C.) tests? How do you test the life cycle of relay's connection point (N.O. / N.C.)? How do you evaluate the connection resistance of connection point (N.O. / N.C.) after multiple tests? How do you evaluate the speed for operating connection point (N.O. / N.C.)?

Relay, functioning to produce mechanical on-off movement by receiving electric signal to change electro magnet, is often applied to control other electronic device via receiving electronic signal. Voltage exerted on relay's coil allows current to pass through coil and magnetizes core. Armature is then be pulled by core due to electromagnetic force. Hence, a mechanical on-off movement is produced.

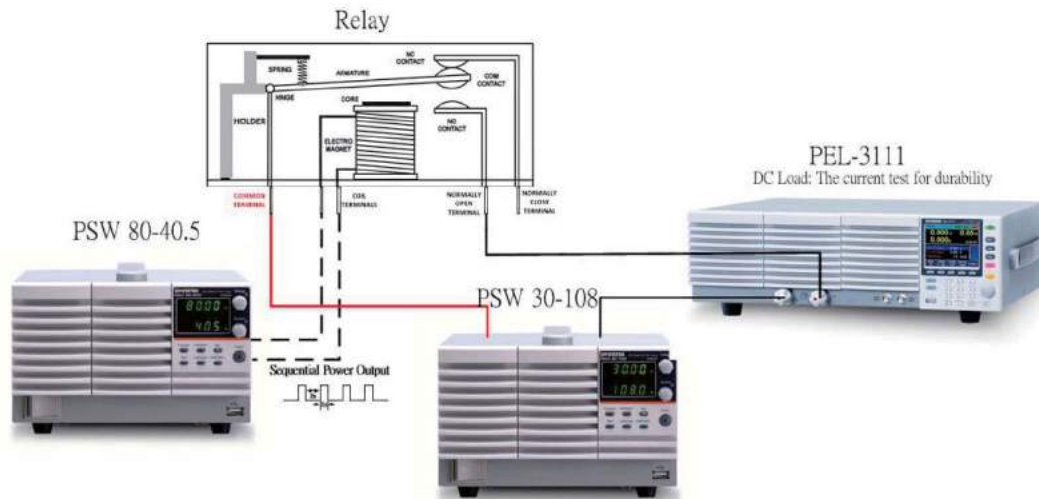

As shown on the top diagram, PSW 30-108, Relay and PEL-3111 are connected by series. PEL-3111 is set to 80A current sink. Each time, Relay's NO-COM is closed, NO-COM is tested for its current reliability. In the meantime, PSW 80-40.5 is utilized to output sequential power supply to produce control signal to control Relay's NO-COM.

One GW Instek PSW 80-40.5 can meet the actual measurement requirements via planning Relay's control signal. It not only controls signal's voltage, current, time and period, but also determines the number of operating cycle. There are totally 20,000 steps and each step can be set from 50ms to 20 days. The number of cycle can reach 1 billion or infinite by different specifications. Relay's control signal can only verify the mechanical characteristics of NO-COM and NC-COM. For further electric characteristic verification of NO-COM and NC-COM, PSW 30-108 and PEL-3111 must be concurrently utilized to produce C.C. output. Based upon Relay's specifications, the combined application of two instruments can conduct fast current switching test and provide large current verification, including current withstanding value and current withstanding time so as to ensure Relay's quality.

Waveforms Measured

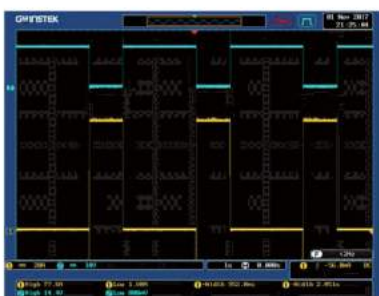

Ch1: Current Waveform

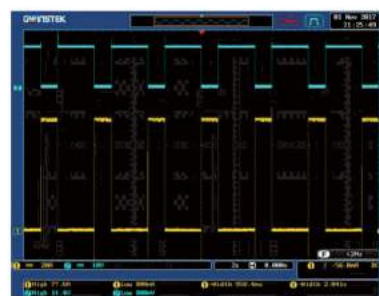

Ch2: Voltage Waveform for Relay 80A for 1s and 0A for 2s

Note:

NO: The NO pin is open to com pin in general unless the power provides to the coil. So it calls Normally Open Terminal of Relay.
 NC: The NC pin is short to com pin in general unless the power provides to the coil. So it calls Normally Closed Terminal of Relay.
 NO-COM: Its a connection status between NO pin and COM pin. It is short when power provides the coil; otherwise, it keeps open.

LED Pulse Current Assessment Test

Electronic load simulates actual loads by drawing current. The drawn current is called load current for power supply that can be used to test the characteristics of power supply or battery. By placing an electronic load in series with a power supply and a load (such as LED Module) and by setting different constant current conditions on the electronic load, the electronic load can draw different current targets from the system loop. The PEL-3000 series features the fast slew rate and the sequence function to simulate real and fast load changes.

The following diagram illustrates a pulse current test system composed of a programmable DC electronic load and a DC power supply to conduct tests on LED illumination characteristics.

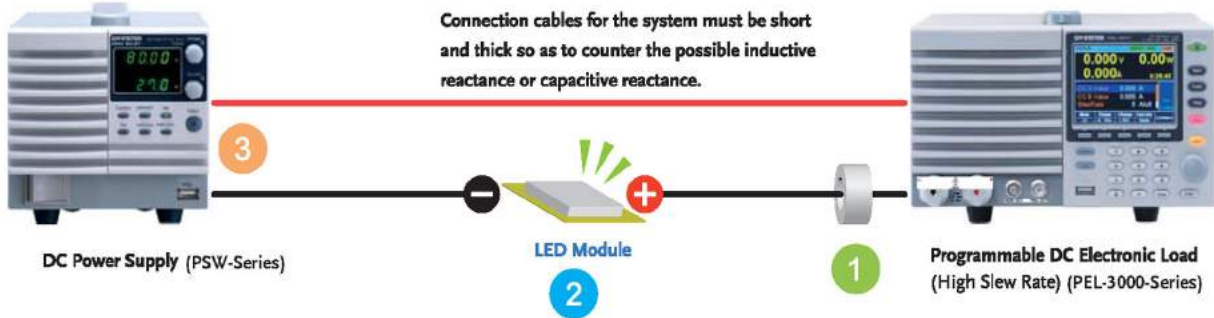

Programmable DC electronic loads, after settings, simulate DUT's pulse current (fast load changes) capability by drawing large and small current. Electronic loads produce pulse current and collocate with the sequence function to execute tests on fast or arbitrary waveform current. Oscilloscope monitors voltage waveform changes for LED and current source. Oscilloscope with a current probe can monitor current waveform in real time.

The lagged or delayed current will cause large transient power consumption when diode is on. Power supply outputs voltage (CV setting) CV is the required voltage for LED. Normally, it exceeds 1.5V.

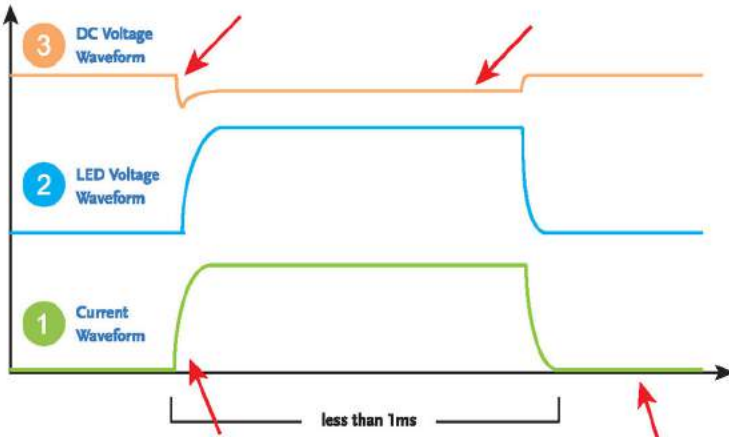

LED module will produce inductive reactance or capacitive reactance due to the length or diameter of wiring. The current waveform will experience delay.

Step-down current can be set as 0A. For a high speed electronic load, real electronic load current can not be 0A. Normally, there is current leakage.

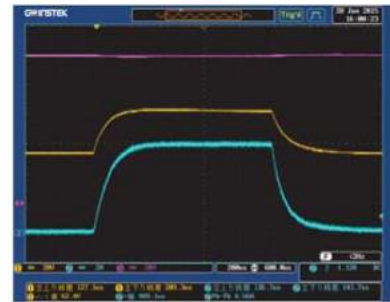

LED Pulse Current Assessment Test:

Benefits of PEL-3000 Series Applications

Construct A Large Pulse Current Source with Lower Costs

Normally, bipolar power is fast in response but it is also very expensive. Therefore, equipment for large pulse current is expensive. The feature of fast switching of electronic load can be used to construct pulse current source with lower costs.

Rating Current Requires Only 1.5V Input Voltage

Power supply outputs voltage - the required voltage of LED is approximately 1.5V, which requires only 1.5V peak value. PEL-3021(175W) can satisfy 35A pulse current requirement with 1.5V voltage input.

For Constant Current Usages and Multiple DUT Applications

Constant current source can be used on changing characteristics for diode device of LED, surface processing (electroplating), pulse charging of rechargeable battery, burn-out of various fuses, and current sensor applications.

The Benefits That PFR-100 Power Supply Can Provide in Burn-in Test

Burn-in is one of many common methods manufacturers utilize to sort out defective components and products during the testing process of the electronic products. Burn-in test is normally conducted in the factory before shipment and after products are completely assembled. Burn-in process helps manufacturers sieve out defective components so as to prevent defective products from being sold to customers. Burn-in test requires additional space for power supplies and its power consumption for a long period of time will increase energy demand and electric bill. Burn-in test is a tremendous cost challenge to all manufacturers in terms of space, electric power and man power. To tackle this cost challenge, GW Instek PFR series can easily assist manufacturers in solving all difficult problems.

* With respect to space, the PFR series provides better space flexibility in the limited test area by its 3U height (H:124/W:70/D:300 mm) and as light as a total weight of 2.5kg.

* Pertaining to power saving, the PFR series, a high-efficiency power conversion power supply, adopts high-efficiency PWM design comparing with low-efficiency linear power supplies. Hence, the PFR series is capable of saving electricity during long-time burn-in test. Compared the same 100W output power supplies, the PFR series requires 143W of input power, while the linear power supplies with 0.5 efficiency require 200W of input power. After a full year of burn-in test, the PFR series will consume 1235 kWh and the linear power supplies will consume 1728kWh. For three years of burn-in test, the PFR series only consumes 3703kWh and linear power supplies consume 5184kWh.

* The PFR series is a five-fold multi-range power supply, which allows users to arbitrarily adjust voltage and current within the rated power. This function allows users to adjust the voltage and current settings according to the maximum output power. Compared with the conventional 100W power supplies with maximum output 20V/5A, the 100W PFR-100L provides a maximum output of 50V@2A or 10V@10A, and the PFR-100M provides an output of up to 250V@0.4A or 50V@2A.

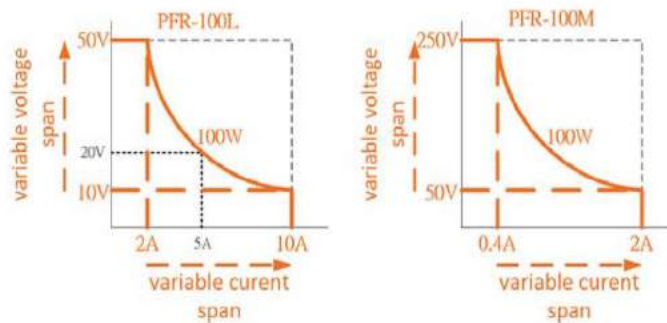

Voltage/Current Operating Area

* In terms of personnel operation, the Test Script function of PFR series edits sequential power outputs based upon customer's burn-in test process and executes automatically during the burn-in procedures. Additionally, the built-in USB, RS-232/485 communications of the PFR series allow testing personnel to remotely control or execute self-defined programs to realize automated tests and reduce manpower investment during burn-in process.

* For power supplies connected to the inside of the Chamber, the phenomenon of voltage drop is often happened due to the long wiring. The PFR series provides the Remote Sense function to compensate the voltage drop so as to ensure an accurate voltage output to the DUT. The operator does not need to adjust voltage for voltage drop.

* Conventional power supplies produce fan noise while in operation. Power supplies with fan design will absorb dust in the fan filter during long-term operation. The accumulated dust may affect the air circulation inside the power supply. Poor air circulation inside the power supply will cause the internal components of the power supply to function under a high-temperature environment. The components that work in the high-temperature environment for a long time will shorten the life cycle of the power supply. The fanless PFR series without fan noise is suitable for a quiet working environment, furthermore, fanless design is ideal for clean and quiet test environment (e.g. clean room). The fanless PFR series can prolong its life cycle during burn-in test.

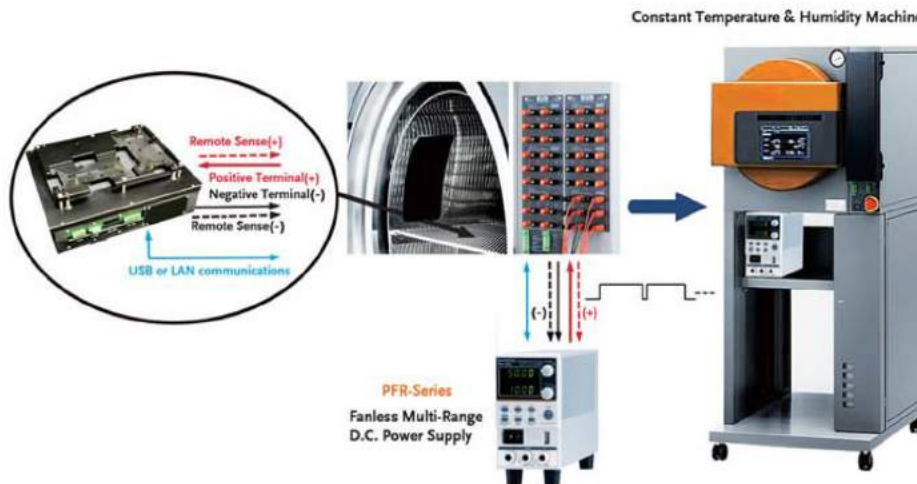

Schematic Diagram for Burn-in Test

Best-fitting Electronic Load for Your Test (Single Channel or Multiple Channels?)

Electronic loads are often simulated as the characteristics (constant resistance, constant voltage or constant current) of the DUTs to test whether the output capability of the battery, power supply, solar cell, or power supply unit meets user's requirements. Unlike using general resistive components to test batteries and power supplies, electronic loads can dynamically switch simulated resistors, voltages or currents, customize the rise and fall times of current sink, and even edit a complex and continuous load change.

THE BASIC APPLICATIONS OF THE SINGLE-CHANNEL DC ELECTRONIC LOAD PEL-3000 SERIES

Current Sensor Evaluation

The PEL-3000 series provides three current levels: high, medium and low. The minimum current resolution of 0.01 mA can be selected based upon the test requirements. If a PEL-3000 collocating with a DC power supply, a high-precision constant current power supply can be formed to evaluate the current sensor.



Current Sensor Evaluation

Solar Panel I-V Curve Display & MPPT Measurement

The MPPT Function can be done by the PEL-3000 series to simulate the operating current of the solar panel ranging from zero to the maximum current value, and at the same time measuring the output voltage and power of the solar panel to obtain the solar panel output voltage/current/power curve. The MPPT Function of the PEL-3000 series not only provides users with the P_{max} , V_{mp} , I_{mp} , I_{sc} , V_{oc} values of the solar panel, but also tracks the maximum power point of the solar panel in different shade conditions.

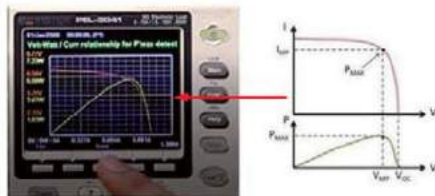

I-V Curve of The Solar Panel



Connections Between PEL-3041 and Solar Panel



Measurements for MPPT

Remark:

- P_{max} → Maximum Power Point
- V_{MP} → Voltage at Maximum Power
- I_{MP} → Current at maximum power
- V_{oc} → Open Circuit Voltage
- I_{sc} → Short Circuit Current

If users need to measure multiple sets of batteries or power supply units at a time, or evaluate multi-channel power output in the circuit, the multi-channel DC electronic load PEL-2000A will be the best measurement solution. PEL-2000A can evaluate the simultaneous power output capability of multiple power supplies, or test the output current of multiple power supplies by sequentially loading each output current according to the time interval defined by each output.

THE BASIC APPLICATIONS OF THE MULTI-CHANNEL DC ELECTRONIC LOAD PEL-2000A SERIES

The Output Test of PC Power Supply

Power supply output devices with small-power, multi-group and different specifications such as the ATX power supply for PCs can use PEL-2000A to evaluate the synchronous power output of multiple power supplies. A typical ATX power supply has 6 outputs. In order to ensure that the ATX power supply can provide sufficient power output when the 6 channels output simultaneously, the PEL-2000A can perform dynamic mode and load regulation tests on six outputs at the same time, or users can edit the Program mode to customize the severe test conditions to automatically determine the Pass or Fail of the ATX

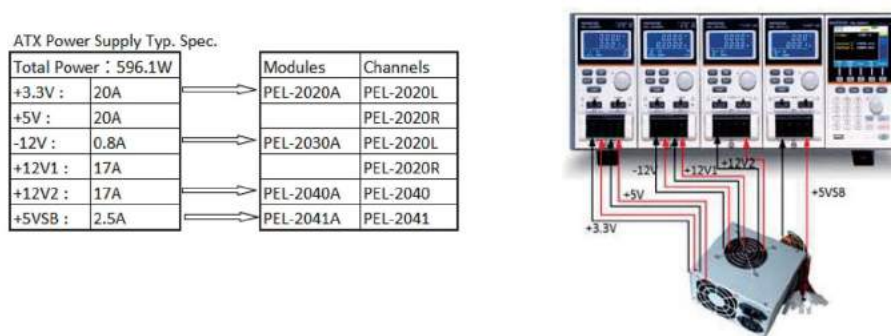

Test Diagram for ATX Power Supply

Battery Evaluation Test

Automated testing of high-speed battery charge and high-speed discharge can be achieved by using the PEL-2000A electronic load module in series and parallel with the power supply. The automated switching operation between the module and the module of the PEL-2000A can greatly shorten the test time and increase the reliability during the measurement process while comparing with the manual operation.

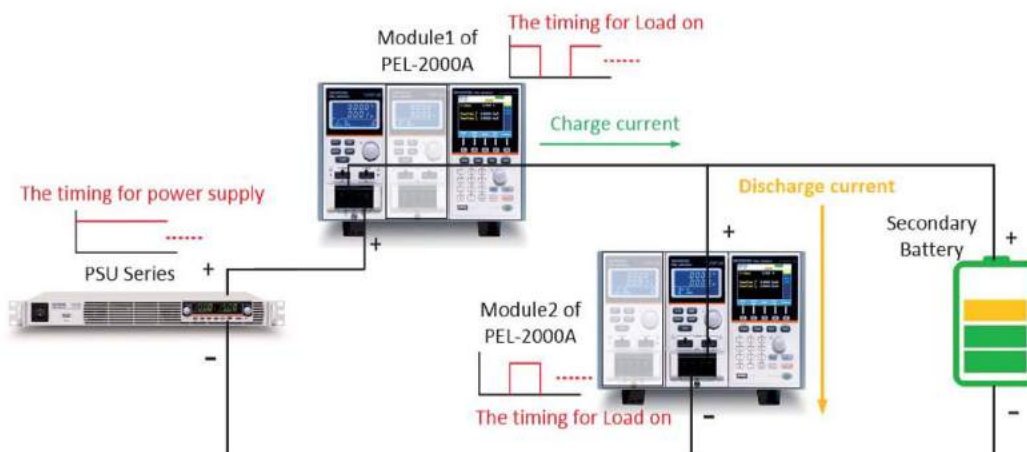

Automated Charge/ Discharge Test with PEL-2000A

Automotive Wire Harness Performance Test System

Automotive Wire Harness Uses Multi-Channel and Continuous Power Supply Test System

Electric wire, installed in the automobile, plays an important role in supplying power and transmitting signals. The importance of electric wire has increased in the wake of the evolution of automotive electrification. For safe and comfortable driving, the reliability test for automotive wire harness is essential. The multi-channel test system, composed of a DC electronic load and a large current power supply, saves time in testing each wire harness and saves space for placing test instruments.

DC power supply and DC electronic load can be rack mounted by customers' electric power wiring test requirements. The following diagram shows many units of PEL-2000A series were used for providing power to multi-channel automotive wire harness in a long period of time.

The PEL-2000A series saves system rack space and costs. The series can flexibly arrange the required number of channels according to the actual requirements of DUTs. The series can also simulate many automotive devices to conduct continuous tests.

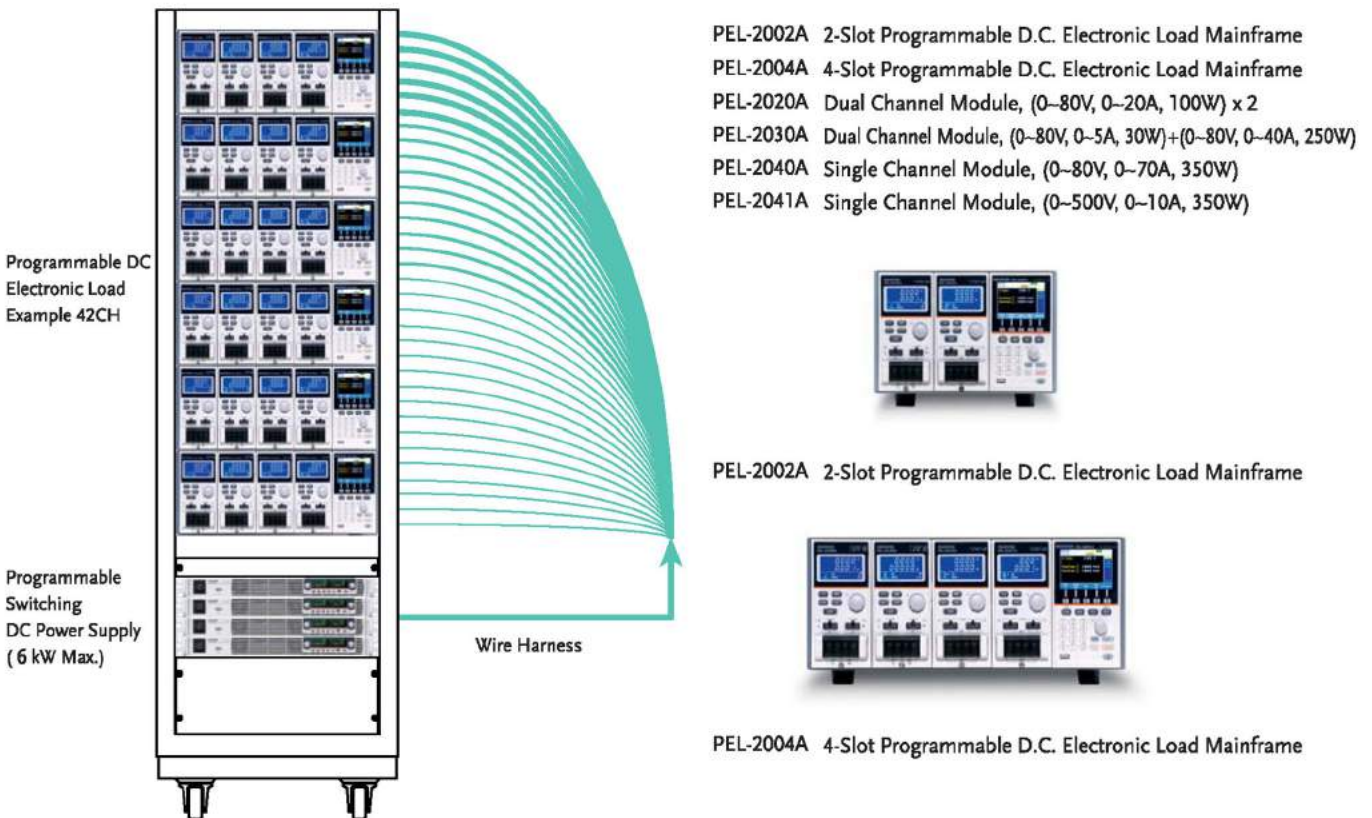

The PEL-2000A series saves system rack space and costs. The PEL-2000A series programmable DC electronic load, via USB or GPIB, can conduct independent control over multiple channels. By using custom-made monitor software, the series can simultaneously control many independent channels.

Test terminal and rack can be custom made. Users' test wire harness required terminal can be jointly mounted on a rack.

Test Script Applications-Solving Complex Test Patterns

The uniqueness of GW Instek Test Script function is to streamline test operator's complex measurement work by directly planning a set of changing voltage and current parameters via Microsoft Excel and uploading the edited Excel file to GW Instek power supplies so as to execute sequential power outputs. The following four test applications with different test patterns were easily executed by GW Instek Test Script function without software programming.

Test Script allows users to run repetitive cycle tests by setting parameters including output voltage, current, time, cycle, OVP, OCP, Bleeder, etc. Four GW Instek Power supplies support Test Script, including PFR, PSU, PSB, and PSW.

PFR-Series



PSU-Series



PSB-Series



PSW-Series

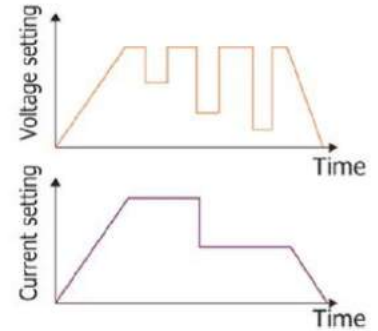

✓ Pattern 1: Pulse Output

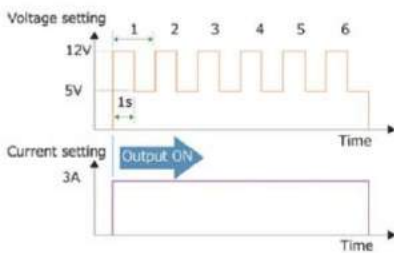

Pattern Setting



Waveform Measurement

Settings: Set and execute a pattern that switches 12V/1sec to 5V/1sec for 6 times with the current setting of 3A.

Test Script Setting :

28	CycleItems	Number	Start Step	End Step							
29	Cycle										
30											
31	Step	Point	Output	Time(sec)	Voltage (V)	Current (A)	Beeper	Sense Aver	Jump to	Jump Cnt	Trig
32		1	Start	0.5	0	0					
33		2	On	1	12	3	On				
34		3	On	1	5	3			2	5	
35		4	end	1	0	0					

✓ Pattern 4: Lifetime test

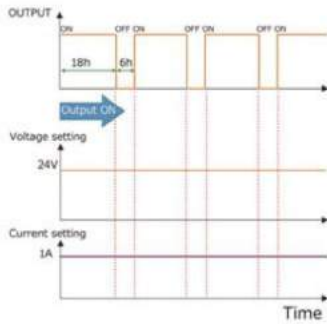

Pattern Setting

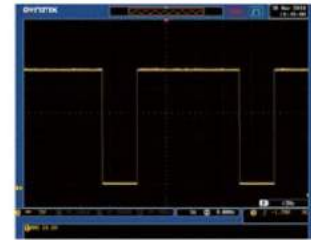
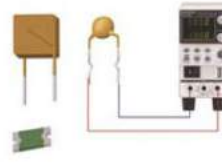

Waveform Measurement

For durability tests such as lights, heaters, etc., pattern that repeats for 18-hour output on and 6-hour output off for 100 days is as follows.

Test Script Setting :

Cycle/Item Number	Start Step	End Step												
27														
28	Cycle	0	1	2										
29														
30														
31	Step	Point	Output	Time(sec)	Voltage (V)	Current (A, OVP(V))	OCF(A)	Bleeder	IV Mode	V _{tr up} (V)	V _{tr down} (V)	I _{tr up} (A/m)	I _{tr down} (A/m)	AIR(ohm)
32	1	Start	On	64800	24	1 MAX	MAX	ON	CVHS	MAX	MAX	MAX	MAX	MIN
33	2	End	Off	21600	24	1 MAX	MAX	ON	CVHS	MAX	MAX	MAX	MAX	MIN
34	3													

✓ Pattern 5: PPTC device (Resettable fuse) test

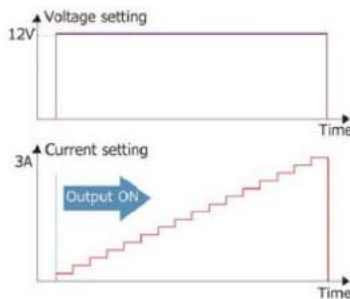

Pattern Setting



Waveform Measurement

A test example of self-resetting PTC verifies its open circuit characteristic by increasing current from 0 to 3A with 16-step resolutions. Test Script can easily execute a series of different currents under a constant voltage setting to test the blown and reset characteristic of a self-resetting PTC.

Test Script Setting :

Cycle/Item Number	Start Step	End Step													
27															
28	Cycle	1	1	16											
29															
30															
31	Step	Point	Output	Time(sec)	Voltage (V)	Current (A, OVP(V))	OCF(A)	Bleeder	IV Mode	V _{tr up} (V)	V _{tr down} (V)	I _{tr up} (A/m)	I _{tr down} (A/m)	AIR(ohm)	Beeper
32	1	Start	On	0.1	12	0.1875 MAX	MAX	ON	OCHS	MAX	MAX	MAX	MAX	MIN	
33	2	On	On	0.1	12	0.375 MAX	MAX	ON	OCHS	MAX	MAX	MAX	MAX	MIN	
34	3	On	On	0.1	12	0.5625 MAX	MAX	ON	OCHS	MAX	MAX	MAX	MAX	MIN	
35	4	On	On	0.1	12	0.75 MAX	MAX	ON	OCHS	MAX	MAX	MAX	MAX	MIN	
36	5	On	On	0.1	12	0.9375 MAX	MAX	ON	OCHS	MAX	MAX	MAX	MAX	MIN	
37	6	On	On	0.1	12	1.125 MAX	MAX	ON	OCHS	MAX	MAX	MAX	MAX	MIN	
38	7	On	On	0.1	12	1.3125 MAX	MAX	ON	OCHS	MAX	MAX	MAX	MAX	MIN	
39	8	On	On	0.1	12	1.5 MAX	MAX	ON	OCHS	MAX	MAX	MAX	MAX	MIN	
40	9	On	On	0.1	12	1.6875 MAX	MAX	ON	OCHS	MAX	MAX	MAX	MAX	MIN	
41	10	On	On	0.1	12	1.875 MAX	MAX	ON	OCHS	MAX	MAX	MAX	MAX	MIN	
42	11	On	On	0.1	12	2.0625 MAX	MAX	ON	OCHS	MAX	MAX	MAX	MAX	MIN	
43	12	On	On	0.1	12	2.25 MAX	MAX	ON	OCHS	MAX	MAX	MAX	MAX	MIN	
44	13	On	On	0.1	12	2.4375 MAX	MAX	ON	OCHS	MAX	MAX	MAX	MAX	MIN	
45	14	On	On	0.1	12	2.625 MAX	MAX	ON	OCHS	MAX	MAX	MAX	MAX	MIN	
46	15	On	On	0.1	12	2.8125 MAX	MAX	ON	OCHS	MAX	MAX	MAX	MAX	MIN	
47	16	End	On	0.1	12	3 MAX	MAX	ON	OCHS	MAX	MAX	MAX	MAX	MIN	
48															

Model Number Index

AP		
APS-001	Accessory – GPIB interface card	D83
APS-002	Accessory – RS-232 / USB interface card	D83
APS-003	Accessory – Output Voltage Capacity (0 – 600Vrms)	D83
APS-004	Accessory – Output Frequency Capacity (45–999.9Hz)	D83
APS-007	Accessory – RS-232 interface card	D83
APS-1102A	1kVA Programmable AC/DC Power Source	D59
APS-7050	500VA Programmable Linear AC Power Source	D61
APS-7100	1000VA Programmable Linear AC Power Source	D61
APS-7050E	500VA AC Power Source	D65
APS-7100E	1000VA AC Power Source	D65
APS-7200	2000VA Programmable Linear AC Power Source	D61
APS-7300	3000VA Programmable Linear AC Power Source	D61
GE		
GET-001	Accessory – Extended terminal for 30V/80V/160V models	D20
GET-002	Accessory – Extended terminal for 250V/800V models	D20
GP		
GPC-1850D	195W, 3-Channel, Linear D.C. Power Supply	D56
GPC-3030D	195W, 3-Channel, Linear D.C. Power Supply	D56
GPC-3030DQ	195W, 3-Channel, Linear D.C. Power Supply	D56
GPC-3060D	375W, 3-Channel, Linear D.C. Power Supply	D56
GPC-6030D	375W, 3-Channel, Linear D.C. Power Supply	D56
GPD-2303S	180W, 2-Channel, Programmable Linear D.C. Power Supply	D47
GPD-3303D	195W, 3-Channel, Programmable Linear D.C. Power Supply	D47
GPD-3303S	195W, 3-Channel, Programmable Linear D.C. Power Supply	D47
GPD-4303S	195W, 4-Channel, Programmable Linear D.C. Power Supply	D47
GPE-1326	192W, Single Channel, Linear D.C. Power Supply	D53
GPE-2323	192W, 2-Channel, Linear D.C. Power Supply	D53
GPE-3323	217W, 3-Channel, Linear D.C. Power Supply	D53
GPE-4323	212W, 4-Channel, Linear D.C. Power Supply	D53
GPP-1326	Single-Output Programmable DC Power Supply	D48
GPP-2323	Dual-Output Programmable DC Power Supply	D48
GPP-3323	Three-Output Programmable DC Power Supply	D48
GPP-4323	Four-Output Programmable DC Power Supply	D48
GPR-0830HD	240W Linear D.C. Power Supply	D42
GPR-100H05D	500W Linear D.C. Power Supply	D41
GPR-11H30D	330W Linear D.C. Power Supply	D42
GPR-16H50D	800W Linear D.C. Power Supply	D41
GPR-1810HD	180W Linear D.C. Power Supply	D43
GPR-1820HD	360W Linear D.C. Power Supply	D42
GPR-1850HDN	900W Linear D.C. Power Supply	D41
GPR-3060D	180W Linear D.C. Power Supply	D43
GPR-30H10D	300W Linear D.C. Power Supply	D42
GPR-3510HD	350W Linear D.C. Power Supply	D42
GPR-6030D	180W Linear D.C. Power Supply	D43
GPR-6060D	360W Linear D.C. Power Supply	D42
GPR-7550D	375W Linear D.C. Power Supply	D41
GPR-3520HD	700W Linear D.C. Power Supply	D41
GPR-6015HD	900W Linear D.C. Power Supply	D41
GPR-7510HD	750W Linear D.C. Power Supply	D41
GPR-25H30D	750W Linear D.C. Power Supply	D41
GPR-35H20D	700W Linear D.C. Power Supply	D41
GPR-50H15D	750W Linear D.C. Power Supply	D41
GPR60H15D	900W Linear D.C. Power Supply	D41
GPR-100H05D	500W Linear D.C. Power Supply	D41
GPR-7510HD	750W Linear D.C. Power Supply	D41
GPR-6015HD	900W Linear D.C. Power Supply	D41
GPR-3520HD	700W Linear D.C. Power Supply	D41
GPS-001	Accessory – Knob, Voltage/Current Protection Knob	D83
GPS-1830D	54W Linear D.C. Power Supply	D44
GPS-1850D	90W Linear D.C. Power Supply	D44
GPS-3030	90W Linear D.C. Power Supply, Analog Display	D44
GPS-3030D	90W Linear D.C. Power Supply	D44
GPS-3030DD	90W Linear D.C. Power Supply	D44
GPS-2303	180W, 2-Channel, Linear D.C. Power Supply	D55
GPS-3303	195W, 3-Channel, Linear D.C. Power Supply	D55
GPS-4303	200W, 4-Channel, Linear D.C. Power Supply	D55
GPW-001	Accessory – UL/CSA Power Cord, 3000mm	D23
GPW-002	Accessory – VDE Power Cord, 3000mm	D23
GPW-003	Accessory – PSE Power Cord, 3000mm	D23
GR		
GRA-401	Accessory – Rack Adapter Kit, 19", 4U Size	D87
GRA-403	Accessory – Rack Adapter Kit, 19", 4U Size	D88
GRA-407	Accessory – Rack Adapter Kit, 19", 4U Size	D88
GRA-408	Accessory – Rack Adapter Kit, 19", 4U Size	D87
GRA-409	Accessory – Rack Adapter Kit, 19", 4U Size	D88
GRA-410-E	Accessory – Rack Mount Kit (EIA), 19", 3U Size	D88
GRA-410-J	Accessory – Rack Mount Kit (JIS), 19", 3U Size	D88

GRA-413	Accessory – Rack Mount Kit (EIA+JIS), 19", 3U Size for PEL-3211	D88
GRA-414-E	Accessory – Rack Mount Kit (EIA), 19", 3U Size for PEL-3021/3041/3111	D88
GRA-414-J	Accessory – Rack Mount Kit (JIS), 19", 3U Size for PEL-3021/3041/3111	D88
GRA-418-E	Accessory – Rack Mount Kit (EIA), 19", 2U Size	D89
GRA-418-J	Accessory – Rack Mount Kit (JIS), 19", 2U Size	D89
GRA-419-E	Accessory – Rack Mount Kit (EIA), 19", 2U Size	D89
GRA-419-J	Accessory – Rack Mount Kit (JIS), 19", 2U Size	D88
GRA-423	Accessory – Rack Mount Kit, 19", 2U Size	D88
GRA-424	Accessory – Rack Mount Kit, 19", 2U Size	D89
GRA-427	Accessory – Rack Mount Kit, 19", 2U Size	D89
GRA-429	Accessory – Rack Mount Kit, 7U Size	D89
GRA-430	Accessory – Rack Mount Kit, 9U Size	D89
GRA-431-J	Accessory – Rack Mount Kit (JIS)	D89
GRA-431-E	Accessory – Rack Mount Kit (EIA)	D89
GRJ-1101	Accessory – Module Cable (0.5m)	D14
GRJ-1102	Accessory – Module Cable (1.5m)	D14
GRM-001	Accessory – Slide bracket 2pcs / set	D23
GT		
GTL-104A	Accessory – Test Lead, U-type to Alligator Test Lead, Max. Current 10A, 1000mm	D87
GTL-105A	Accessory – Test Lead, Alligator to Banana Test Lead, Max. Current 3A, 1000mm	D87
GTL-120	Accessory – Test Lead, O-type to O-type Test Lead, Max. 40A, 1200mm	D87
GTL-121	Accessory – Sense Lead, O-type to free Lead, 1200mm	D87
GTL-122	Accessory – Test Lead, U-type to Alligator Test Lead, Max. Current 40A, 1200mm	D87
GTL-123	Accessory – Test Lead, O-type to O-type Test Lead, 1200mm	D87
GTL-130	Accessory – Test leads: 2 x red, 2 x black, for 250V/800V models, 1200mm	D20
GTL-134	Accessory – Test leads for rear panel, 1200mm, 10A, 16 AWG	D10
GTL-201A	Accessory – Ground Lead, Banana to Banana, European Terminal, 200mm	D87
GTL-202	Accessory – Sense Lead, Banana to Banana Lead, European Terminal, 200mm	D87
GTL-203A	Accessory – Test Lead, Banana to Alligator, European Terminal, Max. Current 3A, 1000mm	D87
GTL-204A	Accessory – Test Lead, Banana to Alligator, European Terminal, Max. Current 10A, 1000mm	D87
GTL-232	Accessory – RS-232C Cable, 9-pin, F-F Type, null modem, 2000mm	D87
GTL-232A	Accessory – RS-232C Cable, 9-pin, F-F Type, null modem, 2000mm	D87
GTL-240	Accessory – USB Cable, USB 2.0, A-B Type (L Type), 1200mm	D87
GTL-246	Accessory – USB Cable, USB 2.0, A-B Type, 1200mm	D87
GTL-248	Accessory – GPIB Cable, Double Shielded, 2000mm	D87
GTL-249	Accessory – Frame Link Cable, 300mm	D84
GTL-255	Accessory – Frame Link Cable, 300mm	D74
GTL-258	Accessory – GPIB Cable, 25 pins Micro-D Connector	D10
GU		
GUG-001	Accessory – GPIB-USB Adaptor, GPIB to USB adaptor	D20
GUR-001	Accessory – RS232-USB Cable, 300mm	D20
PE		
PEL-001	Accessory – GPIB Card	D77
PEL-002	Accessory – Rack Mount Kit, PEL-2000 Series	D77
PEL-003	Accessory – Panel Cover	D77
PEL-004	Accessory – GPIB Card	D77
PEL-005	Accessory – Connect Cu Plate	D77
PEL-006	Accessory – Connect Cu Plate	D77
PEL-007	Accessory – Connect Cu Plate	D77
PEL-008	Accessory – Connect Cu Plate	D77
PEL-009	Accessory – Connect Cu Plate	D77
PEL-010	Accessory – Dust filter	D77
PEL-011	Accessory – Load Input Terminal Cover	D77
PEL-012	Accessory – Terminal Fittings Kits	D77
PEL-013	Accessory – Flexible Terminal Cover	D77
PEL-014	Accessory – J1/J2 Protection Plug	D77
PEL-2002A	2-Slot Programmable D.C. Electronic Load Mainframe	D81
PEL-2004A	4-Slot Programmable D.C. Electronic Load Mainframe	D81
PEL-2020A	200W, Dual Channel D.C. Electronic Load Module, (1–80V, 20A, 100W) x 2	D81
PEL-2030A	200W, Dual Channel D.C. Electronic Load Module, (1–80V, 5A, 30W) & (1–80V, 40A, 250W)	D81
PEL-2040A	350W, Single Channel D.C. Electronic Load Module, (1–80V, 70A, 350W)	D81
PEL-2041A	350W, Single Channel D.C. Electronic Load Module, (2.5–500V, 10A, 350W)	D81
PEL-3021	175W Programmable D.C. Electronic Load	D69
PEL-3041	350W Programmable D.C. Electronic Load	D69
PEL-3111	1050W Programmable D.C. Electronic Load	D69
PEL-3211	2100W Booster Unit for PEL-3111 only	D69
PEL-3212	2100W Programmable D.C. Electronic Load	D69
PEL-3322	3150W Programmable D.C. Electronic Load	D69

PEL-3323	3150W Programmable D.C. Electronic Load	D69
PEL-3424	4200W Programmable D.C. Electronic Load	D69
PEL-3533	5250W Programmable D.C. Electronic Load	D69
PEL-3535	5250W Programmable D.C. Electronic Load	D69
PEL-3744	7350W Programmable D.C. Electronic Load	D69
PEL-3955	9450W Programmable D.C. Electronic Load	D69
PEL-3021H	175W Programmable D.C. Electronic Load	D69
PEL-3041H	350W Programmable D.C. Electronic Load	D69
PEL-3111H	1050W Programmable D.C. Electronic Load	D69
PEL-3211H	2100W Booster Unit for PEL-3111 only	D69
PEL-3212H	2100W Programmable D.C. Electronic Load	D69
PEL-3322H	3150W Programmable D.C. Electronic Load	D69
PEL-3323H	3150W Programmable D.C. Electronic Load	D69
PEL-3424H	4200W Programmable D.C. Electronic Load	D69
PEL-3533H	5250W Programmable D.C. Electronic Load	D69
PEL-3535H	5250W Programmable D.C. Electronic Load	D69
PEL-3744H	7350W Programmable D.C. Electronic Load	D69
PEL-3955H	9450W Programmable D.C. Electronic Load	D69
PEL-3031E	150V/60A/300W Programmable Single-channel D.C. Electronic Load	D75
PEL-3032E	500V/15A/300W Programmable Single-channel D.C. Electronic Load	D75
PF		
PFR-100M	Fanless Multi-range D.C. Power Supply	D9
PFR-100L	Fanless Multi-range D.C. Power Supply	D9
PL		
PLR-GU	Accessory -- GPIB/USB Interface Card	D14
PLR-LU	Accessory -- LAN/USB Interface Card	D14
PLR-ARC	Accessory -- External Analog Control Interface Card	D14
PLR-001	Accessory -- Parallel Connection Signal Cable(2~3 units)	D14
PLR-002	Series Connection Signal Cable	D14
PLR 20-18	(0-20V/0-18A/360W) Low Noise DC Power Supply	D13
PLR 20-36	(0-20V/0-36A/720W) Low Noise DC Power Supply	D13
PLR 36-10	(0-36V/0-10A/360W) Low Noise DC Power Supply	D13
PLR 36-20	(0-36V/0-20A/720W) Low Noise DC Power Supply	D13
PLR 60-6	(0-60V/0-6A/360W) Low Noise DC Power Supply	D13
PLR 60-12	(0-60V/0-12A/720W) Low Noise DC Power Supply	D13
PP		
PPH-1503	45W Programmable High Precision Linear D.C. Power Supply	D35
PPH-1503D	45W/18W Programmable High Precision Linear D.C. Power Supply	D35
PPS-3635	126W Programmable Linear D.C. Power Supply	D45
PPT-1830	138W, 3-Channel, Programmable Linear D.C. Power Supply	D45
PPT-3615	126W, 3-Channel, Programmable Linear D.C. Power Supply	D45
PS		
PSB-001	Accessory -- GPIB Card	D29
PSB-003	Accessory -- Parallel connection kit (for horizontal installation), Kit includes: (PSB-007 joint Kit, Horizontal bus bar x 2, PSB-005 x1)	D29
PSB-004	Accessory -- Parallel connection kit (for vertical installation) Kit includes: (PSB-007 joint Kit, Vertical bus bar x 2, PSB-005 x 1)	D29
PSB-005	Accessory -- Parallel Connection Signal Cable	D29
PSB-006	Accessory -- Serial Connection Signal Cable	D29
PSB-007	Accessory -- Joint Kit: Includes 4 joining plates, [M3x6]screws x 4 ; [M3x8]screw x 2	D29
PSB-008	Accessory -- RS232C Cable (PSB-2000 Only)	D29
PSB-101	Accessory -- Cable for 2 units	D32
PSB-102	Accessory -- Cable for 3 units	D32
PSB-103	Accessory -- Cable for 4 units	D32
PSB-104	Accessory -- Cable for 2 units	D32
PSB-105	Accessory -- GPIB card	D32
PSB-106	Accessory -- Basic accessory kit	D31
PSB-1400L	40V/40A/400W Programmable Multi-Range D.C. Power Supply	D31
PSB-1400M	160V/10A/400W Programmable Multi-Range D.C. Power Supply	D31
PSB-1800L	40V/80A/800W Programmable Multi-Range D.C. Power Supply	D31
PSB-1800M	160V/20A/800W Programmable Multi-Range D.C. Power Supply	D31
PSB-2400H	400W Multi-Range Programmable Switching D.C. Power Supply	D27
PSB-2400L	400W Multi-Range Programmable Switching D.C. Power Supply	D27
PSB-2400L2	800W Multi-Range, 2-Channel, Programmable Switching D.C. Power Supply	D27
PSB-2800H	800W Multi-Range Programmable Switching D.C. Power Supply	D27
PSB-2800L	800W Multi-Range Programmable Switching D.C. Power Supply	D27
PSB-2800LS	800W Slave (Booster) Unit For Current Extension Only	D27
PSH-2018A	360W Programmable Switching D.C. Power Supply	D33
PSH-3610A	360W Programmable Switching D.C. Power Supply	D33
PSH-3620A	720W Programmable Switching D.C. Power Supply	D33
PSH-3630A	1080W Programmable Switching D.C. Power Supply	D33
PSM-2010	200W Programmable Dual-Range Linear D.C. Power Supply	D38
PSM-3004	120W Programmable Dual-Range Linear D.C. Power Supply	D38
PSM-6003	200W Programmable Dual-Range Linear D.C. Power Supply	D38
PSP-2010	200W Programmable Switching D.C. Power Supply	D34
PSP-405	200W Programmable Switching D.C. Power Supply	D34
PSP-603	200W Programmable Switching D.C. Power Supply	D34
PSS-2005	100W Programmable Linear D.C. Power Supply	D39

PSS-3203	96W Programmable Linear D.C. Power Supply	D39
PST-3201	96W, 3-Channel, Programmable Linear D.C. Power Supply	D46
PST-3202	158W, 3-Channel, Programmable Linear D.C. Power Supply	D46
PSU12.5-120	1500W Programmable Switching DC Power Supply	D21
PSU20-76	1520W Programmable Switching DC Power Supply	D21
PSU40-38	1520W Programmable Switching DC Power Supply	D21
PSU60-25	1500W Programmable Switching DC Power Supply	D21
PSU6-200	1200W Programmable Switching DC Power Supply	D21
PSU-01A	Accessory -- Joins a vertical stack of 2 PSU units together. 2U-sized handles x2, joining plates x2	D23
PSU-01B	Accessory -- Bus Bar for 2 units in parallel operation	D23
PSU-01C	Accessory -- Cable for 2 units in parallel operation	D23
PSU-02A	Accessory -- Joins a vertical stack of 3 PSU units together. 3U-sized handles x2, joining plates x2	D23
PSU-02B	Accessory -- Bus Bar for 3 units in parallel operation	D23
PSU-02C	Accessory -- Cable for 3 units in parallel operation	D23
PSU-03A	Accessory -- Joins a vertical stack of 4 PSU units together. 4U-sized handles x2, joining plates x2	D23
PSU-03B	Accessory -- Bus Bar for 4 units in parallel operation	D23
PSU-03C	Accessory -- Cable for 4 units in parallel operation	D23
PSU-232	Accessory -- RS232 Cable with DB9 connector kit	D23
PSU-485	Accessory -- RS485 Cable with DB9 connector kit	D23
PSU-GPIB	Accessory -- PSU GPIB Interface Card (Factory Installed)	D23
PSU-ISO-I	Accessory -- Isolated Current Remote Control Card (Factory	D23
PSU-ISO-V	Accessory -- Isolated Voltage Remote Control Card (Factory	D23
PSW160-14.4	720W Multi-Range Programmable Switching D.C. Power Supply	D17
PSW160-21.6	1080W Multi-Range Programmable Switching D.C. Power Supply	D17
PSW160-7.2	360W Multi-Range Programmable Switching D.C. Power Supply	D17
PSW250-13.5	1080W Multi-Range Programmable Switching D.C. Power Supply	D17
PSW250-4.5	360W Multi-Range Programmable Switching D.C. Power Supply	D17
PSW250-9	720W Multi-Range Programmable Switching D.C. Power Supply	D17
PSW30-108	1080W Multi-Range Programmable Switching D.C. Power Supply	D17
PSW30-36	360W Multi-Range Programmable Switching D.C. Power Supply	D17
PSW30-72	720W Multi-Range Programmable Switching D.C. Power Supply	D17
PSW800-1.44	360W Multi-Range Programmable Switching D.C. Power Supply	D17
PSW800-2.88	720W Multi-Range Programmable Switching D.C. Power Supply	D17
PSW800-4.32	1080W Multi-Range Programmable Switching D.C. Power Supply	D17
PSW80-13.5	360W Multi-Range Programmable Switching D.C. Power Supply	D17
PSW80-27	720W Multi-Range Programmable Switching D.C. Power Supply	D17
PSW80-40.5	1080W Multi-Range Programmable Switching D.C. Power Supply	D17
PSW-001	Accessory -- Accessory Kits	D18
PSW-002	Accessory -- Simple IDC Tool	D18
PSW-003	Accessory -- Contact Removal Tool	D18
PSW-004	Accessory -- Basic Accessory Kit for 30V/80V/160V models	D18
PSW-005	Accessory -- Series Operation Cable for 2 units (for 30V/80V/160V)	D19
PSW-006	Accessory -- Parallel Operation Cable for 2 units	D19
PSW-007	Accessory -- Parallel Operation Cable for 3 units	D19
PSW-008	Accessory -- Basic Accessory Kit for 250V/800V models	D19
PSW-009	Accessory -- Output terminal cover for 30V/80V/160V models	D19
PSW-010	Accessory -- Large filter (Type II/III)	D19
PSW-011	Accessory -- Output terminal cover for 250V/800V models	D19
PSW-012	Accessory -- High voltage output terminal for 250V/800V model	D19
SP		
SPD-3606	375W, 3-Channel, Programmable Switching D.C. Power Supply	D52
SPS-1230	360W Switching D.C. Power Supply	D40
SPS-1820	360W Switching D.C. Power Supply	D40
SPS-2415	360W Switching D.C. Power Supply	D40
SPS-3610	360W Switching D.C. Power Supply	D40
SPS-606	360W Switching D.C. Power Supply	D40



DC POWER SUPPLIES

Stemming from the design and manufacture demands of electronic industries, GW Instek offers diverse power supply product lines to meet user's demand for a variety of applications. Based on different needs, the product lines can be divided into several categories including DC Power Supply, AC Power Source and DC Electronic Load.

For DC Power Supply, the products can be briefly categorized by the following types, Programmable or Non-programmable, Single or Multiple Outputs, High Precision or Affordable Price, Dual Range and Wide Combinations of Voltage and Current, which can be selected to meet the application requirements.

GW Instek offers more than 100 power supply products are suitable for the requirements of Electronic Assembly Testing, Education, Component Testing, Wireless Product Testing, Burn-in, Battery-Power Product Testing Automotive, Aerospace industries and so on.

PRODUCTS

- Programmable & Single Channel DC Power Supply
- Non-Programmable & Single Channel DC Power Supply
- Programmable & Multiple Channel DC Power Supply
- Non-Programmable & Multiple Channel DC Power Supply

DC POWER SUPPLIES

GENERAL SELECTION GUIDE OF POWER SUPPLY BY APPLICATION

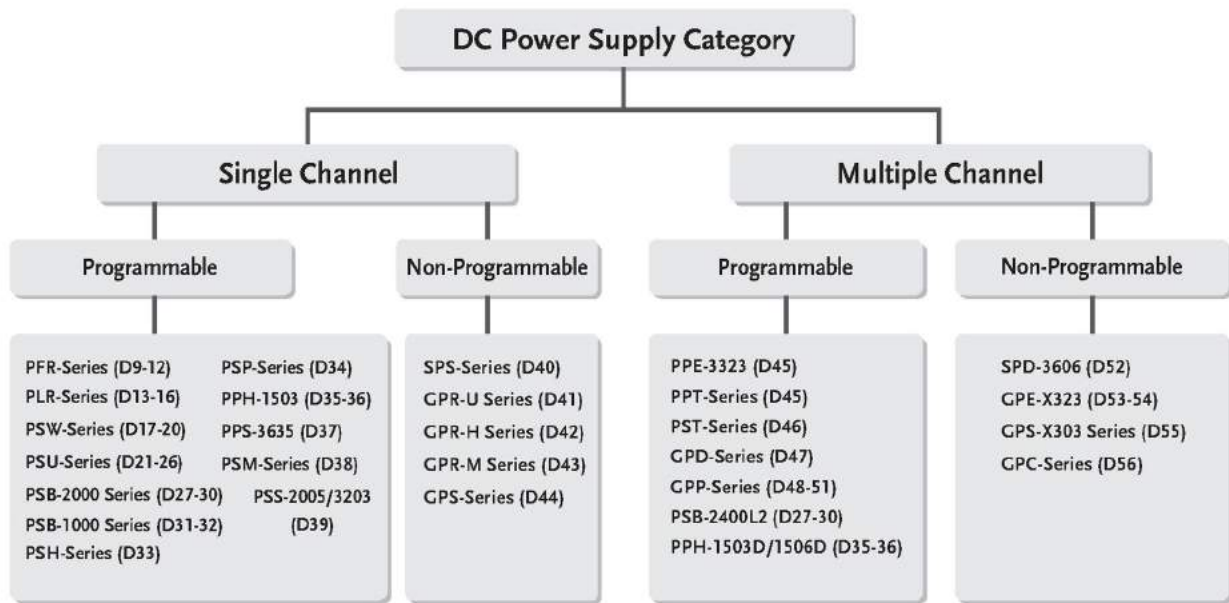

Series	Education	R&D/ Research Lab	Production Testing	ATE for Production	Burn-IN	Page
PFR-Series		✓		✓		D9-12
PLR-Series		✓		✓		D13-16
PSW-Series		✓	✓	✓	✓	D17-20
PSU-Series		✓	✓	✓	✓	D21-26
PSB-2000 Series		✓	✓	✓	✓	D27-30
PSB-1000 Series		✓	✓	✓	✓	D31-32
PSH-Series		✓	✓	✓	✓	D33
PSP-Series	✓	✓		✓		D34
PPH-1503/1503D/1506D		✓	✓		✓	D35-36
PPS-3635	✓	✓	✓	✓		D37
PSM-Series		✓	✓		✓	D38
PSS-Series		✓	✓	✓		D39
SPS-Series			✓	✓	✓	D40
GPR-U Series					✓	D41
GPR-H Series		✓	✓		✓	D42
GPR-M Series		✓	✓		✓	D43
GPS-Series	✓	✓	✓			D44
PPE-3323	✓	✓	✓	✓		D45
PPT-Series	✓	✓	✓	✓		D45
PST-Series	✓	✓	✓	✓		D46
GPD-Series	✓	✓	✓			D47
GPP-Series	✓	✓	✓			D48-51
SPD-3606	✓	✓	✓		✓	D52
GPE-X323	✓	✓	✓			D53-54
GPS-x303 Series	✓	✓	✓			D55
GPC-Series	✓	✓	✓			D56

DC POWER SUPPLIES

GENERAL SELECTION GUIDE OF DC POWER SUPPLY BY FUNCTION

	Programmability	Display	Technic	Model	Page	
Single Channel	Programmable	LED	Switching	PFR-Series	D9-12	
		LED	Switching	PLR-Series	D13-16	
		LED	Switching	PSW-Series	D17-20	
		LED	Switching	PSU-Series	D21-26	
		LCD	Switching	PSH-Series	D33	
		LED	Switching	PSB-2400L/2400H/2800L/2800LS/2800H	D27-30	
		LCD	Switching	PSB-1400L/1400M/1800L/1800M	D31-32	
		LCD	Switching	PSP-603/405/2010	D34	
		LCD	Linear	PPH-1503	D35-36	
		LED	Linear	PPS-3635	D37	
		VFD	Linear	PSM-Series	D38	
		LCD	Linear	PSS-Series	D39	
		LCD	Linear	GPP-1326	D48-51	
		Non-Programmable	LED	Switching	SPS-1230/1820/2415/3610/606	D40
	LED		Dual	Linear	GPR-U Series	D41
	LED		Dual	Linear	GPR-H Series	D42
	LED		Dual	Linear	GPR-M Series	D43
	LED		Linear	GPS-1830D/1850D/3030D/3030DD	D44	
	Analog		Linear	GPS-3030	D44	
	LED		Linear	GPP-1326	D53-54	
Multiple Channel	Programmable	LED	Switching	PSB-2400L2	D27-30	
		LED	Linear	PPE-3323	D45	
		LED	Linear	PPT-1830/3615	D45	
		LCD	Linear	PST-3201/3202	D46	
		LED	Linear	GPD-2303S/3303S/4303S/3303D	D47	
		LCD	Linear	GPP-2323/3323/4323	D48-51	
		LCD	Linear	PPH-1503D	D35-36	
	Non-Programmable	LED	Switching	SPD-3606	D52	
		LED	Dual	Linear	GPC-1850D/3030D/3060D/6030D	D56
		LED	Quad	Linear	GPC-3030DQ	D56
		LED	Quad	Linear	GPS-2303/3303/4303	D55
		LED	Linear	GPE-2303/3303/4303	D53-54	

POWER SUPPLIES

DC POWER SUPPLIES

GENERAL SELECTION GUIDE OF DC POWER SUPPLY BY TECHNIC

Technic	Channel	Programmability	Display	Model	Page	
Switching	Single Channel	Programmable	LED	PFR-Series	D9-12	
			LED	PLR-Series	D13-16	
			LED	PSW-Series	D17-20	
			LED	PSU-Series	D21-26	
			LCD	PSH-Series	D33	
			LED	PSB-2400L/2400H/2800L/2800LS/2800H	D27-30	
			LED	PSB-1400L/1400M/1800L/1800M	D31-32	
			LCD	PSP-603/405/2010	D34	
	Non-Programmable	LED	SPS-1230/1820/2415/3610/606	D40		
	Multiple Channel	Programmable	LED	PSB-2400L2	D27-30	
Non-Programmable		LED	SPD-3606	D52		
Linear	Single Channel	Programmable	LCD	PPH-1503	D35-36	
			LED	PPS-3635	D37	
			VFD	PSM-Series	D38	
			LCD	PSS-Series	D39	
			LCD	GPP-1326	D48-51	
		Non-Programmable	LED	Dual	GPR-U Series	D41
			LED	Dual	GPR-H Series	D42
			LED	Dual	GPR-M Series	D43
			LED		GPS-1830D/1850D/3030D/3030DD	D44
			Analog		GPS-3030	D44
	LED		GPE-1326	D49-50		
	Multiple Channel	Programmable	LED	PPE-3323	D45	
			LED	PPT-1830/3615	D45	
			LCD	PPH-1503D/1506D	D35-36	
			LCD	PST-3201/3202	D46	
			LED	GPD-2303S/3303S/4303S/3303D	D47	
			LCD	GPP-2323/3323/4323	D48-51	
		Non-Programmable	LED	Dual	GPC-1850D/3030D/3060D/6030D	D56
			LED	Quad	GPC-3030DQ	D56
			LED	Quad	GPS-2303/3303/4303	D55
LED				GPE-2303/3303/4303	D53-54	

DC POWER SUPPLIES

PROGRAMMABLE & SINGLE CHANNEL DC POWER SUPPLY

Voltage(V)	Current(A)	Power(W)	Model	Display	Technic	Remark	Page
6	200	1200	PSU 6-200	LED	Switching	USB/LAN/RS-232/RS-485/GPIB(Opt)	D21-26
8	20	200	PSM-2010	VFD	Linear	DUAL RANGE, RS-232/GPIB	D38
12.5	120	1500	PSU 12.5-120	LED	Switching	USB/LAN/RS-232/RS-485/GPIB(Opt)	D21-26
15	3	45	PPH-1503	LCD	Linear	9V/5A or 15V/3A, USB/LAN/GPIB	D35-36
15	7	120	PSM-3004	VFD	Linear	DUAL RANGE, RS-232/GPIB	D38
20	18	360	PLR 20-18	LED	Switching	RS-232/LAN(Opt)/USB(Opt)/GPIB(Opt)	D13-16
20	36	720	PLR 20-36	LED	Switching	RS-232/LAN(Opt)/USB(Opt)/GPIB(Opt)	D13-16
20	76	1520	PSU 20-76	LED	Switching	USB/LAN/RS-232/RS-485/GPIB(Opt)	D21-26
20	18	360	PSH-2018A	LCD	Switching	RS-232/GPIB(Opt)	D33
20	10	200	PSP-2010	LCD	Switching	RS-232	D34
20	10	200	PSM-2010	VFD	Linear	DUAL RANGE, RS-232/GPIB	D38
20	5	100	PSS-2005	LCD	Linear	RS-232/GPIB(Opt)	D39
30	36	360	PSW 30-36	LED	Switching	USB/LAN/USB-GPIB(Opt)	D17-20
30	72	720	PSW 30-72	LED	Switching	USB/LAN/USB-GPIB(Opt)	D17-20
30	108	1080	PSW 30-108	LED	Switching	USB/LAN/USB-GPIB(Opt)	D17-20
30	4	120	PSM-3004	VFD	Linear	DUAL RANGE, RS-232/GPIB	D38
30	6	200	PSM-6003	VFD	Linear	DUAL RANGE, RS-232/GPIB	D38
32	3	96	PSS-3203	LCD	Linear	RS-232/GPIB(Opt)	D39
32	6	192	GPP-1326	LCD	Linear	RS-232/USB(CDC)/LAN(Opt)/GPIB(Opt)	D48-51
36	10	360	PLR 36-10	LED	Switching	RS-232/LAN(Opt)/USB(Opt)/GPIB(Opt)	D13-16
36	20	720	PLR 36-20	LED	Switching	RS-232/LAN(Opt)/USB(Opt)/GPIB(Opt)	D13-16
36	10	360	PSH-3610A	LCD	Switching	RS-232/GPIB(Opt)	D33
36	20	720	PSH-3620A	LCD	Switching	RS-232/GPIB(Opt)	D33
36	30	1080	PSH-3630A	LCD	Switching	RS-232/GPIB(Opt)	D33
36	3.5	126	PPS-3635	LED	Linear	36V/3.5A, GPIB	D37
40	38	1520	PSU 40-38	LED	Switching	USB/LAN/RS-232/RS-485/GPIB(Opt)	D21-26
40	5	200	PSP405	LCD	Switching	RS-232	D34
60	6	360	PLR 60-6	LED	Switching	RS-232/LAN(Opt)/USB(Opt)/GPIB(Opt)	D13-16
60	12	720	PLR 60-12	LED	Switching	RS-232/LAN(Opt)/USB(Opt)/GPIB(Opt)	D13-16
60	3.5	200	PSP-603	LCD	Switching	RS-232	D34
50	10	100	PFR-100L	LED	Switching	USB/RS-232/RS-485/LAN(Opt)/GPIB(Opt)	D9-12
60	3.3	200	PSM-6003	VFD	Linear	DUAL RANGE, RS-232/GPIB	D38
60	25	1500	PSU 60-25	LED	Switching	USB/LAN/RS-232/RS-485/GPIB(Opt)	D21-26
80	13.5	360	PSW 80-13.5	LED	Switching	USB/LAN/USB-GPIB(Opt)	D17-20
80	27	720	PSW 80-27	LED	Switching	USB/LAN/USB-GPIB(Opt)	D17-20
80	40.5	1080	PSW 80-40.5	LED	Switching	USB/LAN/USB-GPIB(Opt)	D17-20
80	40	400	PSB-2400L	LED	Switching	RS-232/USB/GPIB(Opt)	D27-30
80	80	800	PSB-2800L	LED	Switching	RS-232/USB/GPIB(Opt)	D27-30
80	80	800	PSB-2800LS	LED	Switching	RS-232/USB/GPIB(Opt)	D27-30
100	15	1500	PSU 100-15	LED	Switching	USB/LAN/USB-GPIB(Opt)	D21-26
150	10	1500	PSU 150-10	LED	Switching	USB/LAN/USB-GPIB(Opt)	D21-26

DC POWER SUPPLIES

Voltage(V)	Current(A)	Power(W)	Model	Display	Technic	Remark	Page
160	7.2	360	PSW 160-7.2	LED	Switching	USB/LAN/USB-GPIB(Opt)	D17-20
160	14.4	720	PSW 160-14.4	LED	Switching	USB/LAN/USB-GPIB(Opt)	D17-20
160	21.6	1080	PSW 160-21.6	LED	Switching	USB/LAN/USB-GPIB(Opt)	D17-20
250	2	100	PFR-100M	LED	Switching	USB/RS-232/RS-485/LAN(Opt)/GPIB(Opt)	D9-12
250	4.5	360	PSW 250-4.5	LED	Switching	USB/LAN/USB-GPIB(Opt)	D17-20
250	9	720	PSW 250-9	LED	Switching	USB/LAN/USB-GPIB(Opt)	D17-20
250	13.5	1080	PSW 250-13.5	LED	Switching	USB/LAN/USB-GPIB(Opt)	D17-20
300	5	1500	PSU 300-5	LED	Switching	RS-232/USB/LAN/USB-GPIB(Opt)	D21-26
400	3.8	1520	PSU 400-3.8	LED	Switching	RS-232/USB/LAN/USB-GPIB(Opt)	D21-26
600	2.6	1560	PSU 600-2.6	LED	Switching	RS-232/USB/LAN/USB-GPIB(Opt)	D21-26
800	1.44	360	PSW 800-1.44	LED	Switching	USB/LAN/USB-GPIB(Opt)	D17-20
800	2.88	720	PSW 800-2.88	LED	Switching	USB/LAN/USB-GPIB(Opt)	D17-20
800	4.32	1080	PSW 800-4.32	LED	Switching	USB/LAN/USB-GPIB(Opt)	D17-20
800	3	400	PSB-2400H	LED	Switching	RS-232/USB/GPIB(Opt)	D31-32
800	6	800	PSB-2800H	LED	Switching	RS-232/USB/GPIB(Opt)	D31-32

DC POWER SUPPLIES

NON-PROGRAMMABLE & SINGLE CHANNEL DC POWER SUPPLY

Voltage(V)	Current(A)	Power(W)	Model	Display	Technic	Remark	Page
8	30	240	GPR-0830HD	LED	Linear	Rear-Panel Output	D42
12	30	360	SPS-1230	LED	Switching	Rear-Panel Output	D40
18	3	54	GPS-1830D	LED	Linear	Rear-Panel Output	D44
18	5	90	GPS-1850D	LED	Linear		D44
18	10	180	GPR-1810HD	LED	Linear	Rear-Panel Output	D43
18	20	360	SPS-1820	LED	Switching	Rear-Panel Output	D40
18	20	360	GPR-1820HD	LED	Linear	Rear-Panel Output	D42
18	50	900	GPR-1850HDN	LED	Linear	Rear-Panel Output	D41
24	15	360	SPS-2415	LED	Switching		D40
30	3	90	GPS-3030D	LED	Linear	Rear-Panel Output	D44
30	3	90	GPS-3030DD	LED	Linear		D44
30	3	90	GPS-3030	Analog	Linear		D44
30	6	180	GPR-3060D	LED	Linear	Rear-Panel Output	D43
32	6	192	GPE-1326	LED	Linear	Front-Panel Output	D53-54
35	10	350	GPR-3510HD	LED	Linear	Rear-Panel Output	D42
35	20	700	GPR-3520HDA	LED	Linear		D41
36	10	360	SPS-3610	LED	Switching	Rear-Panel Output	D40
60	3	180	GPR-6030D	LED	Linear	Rear-Panel Output	D43
60	6	360	SPS-606	LED	Switching	Rear-Panel Output	D40
60	6	360	GPR-6060D	LED	Linear	Rear-Panel Output	D42
60	15	900	GPR-6015HDA	LED	Linear	Rear-Panel Output	D41
75	5	375	GPR-7550D	LED	Linear	Rear-Panel Output	D42
75	10	750	GPR-7510HDA	LED	Linear	Rear-Panel Output	D41
110	3	330	GPR-11H30D	LED	Linear	Rear-Panel Output	D42
160	5	800	GPR-16H50DA	LED	Linear	Rear-Panel Output	D41
250	3	750	GPR-25H30DA	LED	Linear	Rear-Panel Output	D41
300	1	300	GPR-30H10D	LED	Linear	Rear-Panel Output	D42
350	2	700	GPR-35H20DA	LED	Linear	Rear-Panel Output	D41
500	1.5	750	GPR-50H15DA	LED	Linear	Rear-Panel Output	D41
600	1.5	900	GPR-60H15DA	LED	Linear	Rear-Panel Output	D41
1000	0.5	500	GPR-100H05DA	LED	Linear	Rear-Panel Output	D41
75	10	750	GPR-7510HDC	LED	Linear	Rear-Panel Output	D41
60	15	900	GPR-6015HDC	LED	Linear	Rear-Panel Output	D41
35	20	700	GPR-3520HDC	LED	Linear	Rear-Panel Output	D41

DC POWER SUPPLIES

PROGRAMMABLE & MULTIPLE CHENNEL DC POWER SUPPLY

Voltage(V)	Current(A)	Power (W)	Model	CH	Display	Technic	Remark	Page
15	3	63	PPH-1503D	2	LCD	Linear	15V/3A or 9V/5A x 1, 12V/1.5A x 1 GPIB/LAN/GPIB	D35-36
15	3	81	PPH-1506D	2	LCD	Linear	15V/3A or 9V/5A x 1, 12V/3A x 1 GPIB/LAN/GPIB	D35-36
18	3	138	PPT-1830	3	LED	Linear	18V/3A x 2, 6V/5A x 1 GPIB	D45
30	3	180	GPD-2303S	2	LED	Linear	30V/3A x 2 USB	D47
30	3	195	GPD-3303S	3	LED	Linear	30V/3A x 2 (2.5/3.3/5V)/3A x 1, USB	D47
30	3	195	GPD-4303S	4	LED	Linear	30V/3A x 2; (5V/3A) or (5.0V~10V/1A) x 1; 5V/1A, USB	D47
30	3	195	GPD-3303D	3	LED	Linear	30V/3A x 2 (2.5/3.3/5V)/3A x 1, USB	D47
32	3	207	PPE-3323	3	LED	Linear	±32V/3A; -32V/-3A 3.3V(5V)/3A FIXED; RS-232	D45
32	1	96	PST-3201	3	LCD	Linear	32V/1A x 3 RS-232/GPIB (Opt)	D46
32	2	158	PST-3202	3	LCD	Linear	32V/2A x 2, 6V/5A x 1 RS-232/GPIB (Opt)	D46
32	3	192	GPP-2323	2	LCD	Linear	32V/3A x 2, RS-232/USB(CDC)/ LAN(Opt)/GPIB(Opt)	D48-51
32	3	217	GPP-3323	3	LCD	Linear	32V/3A x 2, (1.8/2.5/3.3/5.0V)/5A x 1 RS-232/USB(CDC)/LAN(Opt)/GPIB(Opt)	D48-51
32	3	212	GPP-4323	4	LCD	Linear	32V/3A x 2, 5V/1A x 1, 15V/1A x 1 RS-232/USB(CDC)/LAN(Opt)/GPIB(Opt)	D48-51
36	1.5	126	PPT-3615	3	LED	Linear	36V/1.5A x 2 6V/3A x1; GPIB	D45
80	40	800	PSB-2400L2	2	LED	Switching	80V/40A x 2 RS-232/USB/GPIB (Opt)	D27-30

NON-PROGRAMMABLE & MULTIPLE CHENNEL DC POWER SUPPLY

Voltage(V)	Current(A)	Power (W)	Model	CH	Display	Technic	Remark	Page
18	5	195	GPC-1850D	3	LED	Linear	18V/5A x 2; 5V/3A x 1	D56
30	6	375	SPD-3606	3	LED	Switching	30V/6A x 2; 5V/3A x 1	D44
30	3	195	GPC-3030D	3	LED	Linear	30V/3A x 2; 5V/3A x 1	D56
30	6	375	GPC-3060D	3	LED	Linear	30V/6A x 2; 5V/3A x 1	D56
30	3	195	GPC-3030DQ	3	LED	Linear	30V/3A x 2; 5V/3A x 1	D56
30	3	180	GPS-2303	3	LED	Linear	30V/3A x 2	D55
30	3	195	GPS-3303	3	LED	Linear	30V/3A x 2; 5V/3A x 1	D55
30	3	200	GPS-4303	4	LED	Linear	30V/3A x 2; 5V/1A x 1; 15V/1A x 1	D55
32	3	192	GPE-2323	2	LED	Linear	32V/3A x 2	D53-54
32	3	217	GPE-3323	3	LED	Linear	32V/3A x 2; 5V/5A x 1	D53-54
32	3	212	GPE-4323	4	LED	Linear	32V/3A x 2; 5V/1A x 1; 15V/1A x 1	D53-54
60	3	375	SPD-3606	3	LED	Switching	60V/3A x 2; 5V/3A x 1	D52
60	3	375	GPC-6030D	3	LED	Linear	60V/3A x 2; 5V/3A x 1	D56

Fanless Multi-Range D.C. Power Supply



NEW

PFR-100L



NEW

PFR-100M



FEATURES

- * Constant Power Output for Fivefold Multi-Range(V&I) Operation
- * Natural Convection Cooling Design (Fanless Structure)
- * Preset Memory Function
- * Output ON/OFF Delay Function
- * CV, CC Priority Mode
- * Adjustable Slew Rate For Voltage and Current
- * Bleeder Circuit Control
- * Protection : OVP, OCP, AC FAIL and OTP
- * Support Front Panel and Rear Panel Output
- * Built-in USB and RS-232/485 Interface
- Optional LAN+GPIB
- * Web Server Monitoring and Control
- * External Analog Control and Monitor Function
- * Remote Sensing Function

Model	PFR-100L	PFR-100M
Output Channel	1	1
Output Voltage	0~ 50V	0~ 250V
Output Current	0~ 10A	0~ 2A
Rated Power	100W	100W

The PFR-100 series, a small and high-performance programmable D.C. power supply, adopts natural convection design to dissipate heat. The fanless structure allows users to focus on their experiments and tests in a quiet environment. Fanless power supply will not suck in dust and foreign objects, therefore, PFR-100 series has a longer life cycle compared with that of power supplies with fan.

The PFR-100 series is a power supply with a five-fold rated power that allows users to self-define voltage and current under rated power conditions so as to satisfy them with wider voltage and current operational ranges. PFR-100 series, with rated 100W, provides two models: PFR-100L- maximum output voltage of 50V (at 2A) or maximum output current of 10A (at 10V); PFR-100M- maximum output voltage of 250V (at 0.4A) or maximum output current of 2A (at 50V).

The PFR-100 series provides front and rear panel output terminals. The front panel output terminal helps users shorten test lead replacement time while conducting adjustment on front panel's function keys. The rear panel output terminal facilitates an easy wiring operation for rackmount assembly. 3U height, 70mm width and 2.5KG in weight have greatly elevated PFR-100 series portability. Furthermore, the multi-drop mode allows users to control up to 31 PFR-100 series without using switch/Hub that help users save the equipment cost.

The LAN interface for PFR-100 is Ethernet port. PFR-100 also has a built-in web server and intuitive user interface. Users, via general browsers including Internet Explorer, Mozilla Firefox or Android cellular phones, can monitor PFR-100's test and measurement anywhere. Users not only can remotely monitor PFR-100 via internet, but also remotely observe and adjust their operating PFR-100s in the lab from your home. The outputs of PFR-100 series can be monitored including OVP, OCP, UVL; and the system information can be checked such as unit's serial number, firmware edition and internet setting. Users can remotely adjust PFR-100 settings, including output voltage/current, the slew rate for voltage/current, Bleeder circuit control, OCP, delayed time for output voltage and Buzzer settings.

The PFR-100 series provides special functionalities to meet test requirements for different load's characteristics. The CC priority mode can be applied for DUTs with diode characteristics to prevent DUT from being damaged by inrush current. A slow rise time for voltage can also protect DUT from inrush current, especially for tests on capacitive load. When power is off or load is disconnected, the activation of Bleeder circuit control will allow the bleeder resistor to consume filter capacitor's electricity. Without the bleed resistor, power supply's filter capacitor may still have electricity that is a potential hazard. For automatic testing equipment systems, the bleeder resistor allows PFR-100 series to rapidly discharge to prepare itself for the next operation.

SPECIFICATIONS

Model		PFR-100L	PFR-100M
OUTPUT RATING			
Rated Output Voltage		50V	250V
Rated Output Current		10A	2A
Rated Output Power		100W	100W
REGULATION(CV)			
Load Regulation ([±] 2)		10mV	33mV
Line Regulation ([±] 1)		3mV	5mV
REGULATION(CC)			
Load Regulation ([±] 9)		10mA	3.2mA
Line Regulation ([±] 1)		8mA	1.2mA
RIPPLE & NOISE ([±]3)			
Vp-p ([±] 4)		50mV	150mV
Vr.m.s.([±] 5)		4mV	15mV
A r.m.s.		10mA	2mA
PROGRAMMING ACCURACY			
Voltage	0.1% of setting +	40mV	200mV
Current	0.2% of setting +	20mA	2mA
MEASUREMENT ACCURACY			
Voltage	0.1% of reading +	40mV	200mV
Current	0.2% of reading +	20mA	2mA
RESPONSE TIME			
Rise Time ([±] 6)	Rated load	50ms	100ms
Fall Time ([±] 7)	Rated load	100ms	200ms
	No load	500ms	1000ms
Transient Response Time ([±] 8)		1.5ms	2ms
PROGRAMMING RESOLUTION			
Voltage		2mV	10mV
Current		1mA	0.1mA
MEASUREMENT RESOLUTION			
Voltage		2mV	10mV
Current		1mA	0.1mA
PROTECTION FUNCTION			
Over Voltage Protection (OVP)	Setting range	5~55V	5~275V
Over Current Protection (OCP)	Setting range	1~11A	0.2~2.2A
Under Voltage Limit (UVL)	Setting range	0~52.5V	0~262.5V
Over Temperature Protection (OTP)	Operation	Turn the output off.	Turn the output off.
Low AC Input Protection (AC-Fail)	Operation	Turn the output off.	Turn the output off.
Power Limit (Power Limit)	Operation	Turn the output off.	Turn the output off.



PFR-Series

SPECIFICATIONS

Model		PFR-100L	PFR-100M
FRONT PANEL DISPLAY ACCURACY, 4 DIGITS			
Voltage	0.1% of reading +	40mV	200mV
Current	0.2% of reading +	20mA	2mA
ENVIRONMENT CONDITION			
Operating Temperature		0 °C to 40 °C	
Storage Temperature		-20 °C to 70 °C	
Operating Humidity		20% to 80% RH; No condensation	
Storage Humidity		20% to 85% RH; No condensation	
READBACK TEMP. COEFFICIENT(After A 30 Minute Warm-up)			
Voltage		100ppm/°C	
Current		200ppm/°C	
OTHER			
Analog Control		Yes	
Interface		USB, RS-232/RS-485; Factory option: LAN/GPIB	
AC Input		85~265VAC, 47~63Hz, single phase	
DIMENSIONS & WEIGHT			
70(W)x124(H)x300(D)mm; Approx. 2.5kg			

Note: *1: At 85 ~ 132Vac or 170 ~ 265Vac, constant load.
 *2: From No-load to Full-load, constant input voltage. Measured at the sensing point in Remote Sense.
 *3: Measure with JEITA RC-9131B (1:1) probe
 *4: Measurement frequency bandwidth is 10Hz to 20MHz.
 *5: Measurement frequency bandwidth is 5Hz to 1MHz.
 *6: From 10%~90% of rated output voltage, with rated resistive load.
 *7: From 90%~10% of rated output voltage, with rated resistive load.
 *8: Time for output voltage to recover within 0.1% + 10mV of its rated output for a load change from 50 to 100% of its rated output current.
 *9: For load voltage change, equal to the unit voltage rating, constant input voltage.

ORDERING INFORMATION

PFR-100L Fanless Multi-Range D.C. Power Supply

PFR-100M Fanless Multi-Range D.C. Power Supply

ACCESSORIES :

CD(User Manual, Programming manual) x 1, Power cord, GTL-134 test lead, Accessory Packages
 GTL-104A test lead (for PFR-100L only), GTL-105A test lead (for PFR-100M only)

OPTIONAL ACCESSORIES

GTL-258 GPIB Cable, 2000mm
PSU-232 RS-232 Cable with DB9 Connector Kit
PSU-485 RS-485 Cable with DB9 Connector Kit
GTL-246 USB Cable (USB 2.0 Type A-TypeB Cable)
GRA-431-J-100/200 Rack mount Kit(JIS)with AC 100V/200V
GRA-431-E-100/200 Rack mount Kit(EIA)with AC 100V/200V
PFR-GL LAN+GPIB interface

PFR-100 Series Fanless Multi-Range D.C. Power Supply

PFR-100□ - GL - GTL-258

Model: L: 0-50V/10A/100W
 M: 0-250V/2A/100W

Cable Options:
GTL-258: A GPIB cable including 25 pins Micro-D connector
PSU-232: An RS-232 cable including RJ-45 connector
PSU-485: An RS-485 cable including RJ-45 connector
GTL-246: A USB cable for TypeA-TypeB connectors

Interface Options:
 None
 USB (Type B) & RS-232/RS-485 (RJ-45 connector) as default
 LAN & GPIB (25 pins Micro-D connector)

Rear Panel



GRA-431-J/E Rack Mount Kit(JIS/EIA)

For: PFR-Series



PSU-232 RS-232 Cable with DB9 Connector Kit



PSU-485 RS-485 Cable with DB9 Connector Kit



GTL-258 GPIB Cable, 2000mm



GTL-134 Test Lead



Fanless Multi-Range D.C. Power Supply

A. C.V/C.C PRIORITY MODE

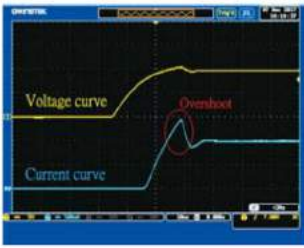

Under the conventional C.V mode, inrush current and surge voltage appeared at forward voltage (V_f) of LED

Under the application conditions of diode load, conventional power supplies under the C.V priority mode will produce inrush current and surge voltage at turn-on. The PFR-100 series has C.V and C.C priority modes. The C.C priority mode can prevent inrush current and surge voltage from occurring at turn-on to protect DUT.

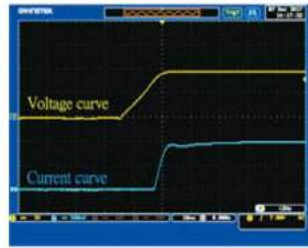

Under C.C priority mode, inrush and surge voltage are effectively restrained.

B. ADJUSTABLE SLEW RATE

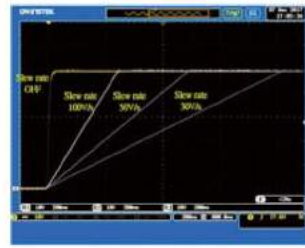

Adjustable Voltage Slew Rate

Voltage Slew Rate
0.1V~100.0V/sec (PFR-100L)
0.1V~500.0V/sec (PFR-100M)

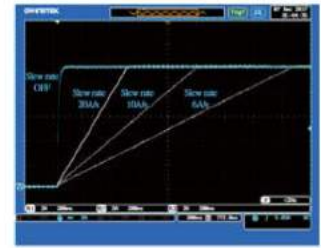

Adjustable Current Slew Rate

Current Slew Rate
0.01A~20.00A/sec (PFR-100L)
0.001A~4.000A/sec (PFR-100M)

The PFR-100 series can adjust slew rate for current and voltage. Via setting the rise and fall time of voltage and current, users can verify DUT's characteristics during voltage and current variation. Additionally, slew rate adjustment can mitigate voltage shift to effectively prevent DUT from being damaged by inrush current. This function is ideal for tests such as capacitive load and motor.

C. WEB SERVER REMOTE CONTROL FUNCTION

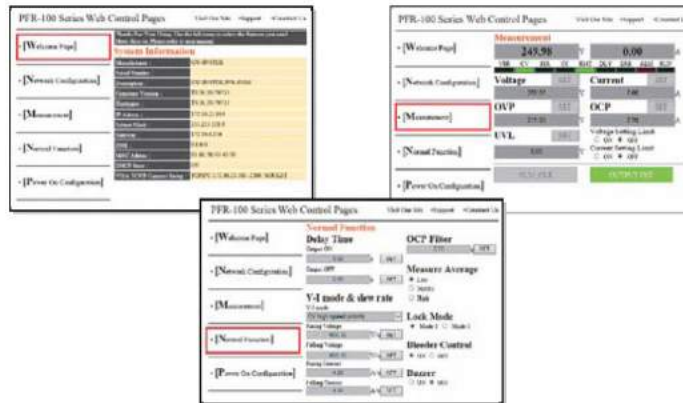

Users, via general browsers including Internet Explorer, Mozilla Firefox or Android cellular phones, can monitor PFR-100's test and measurement anywhere. Users not only can remotely monitor PFR-100 via internet, but also remotely observe and adjust your operating PFR-100 in the lab from your home. The outputs of PFR-100 can be monitored including OVP, OCP, UVL; and system

information can be checked such as unit's serial number, firmware edition and internet setting. Users can remotely adjust PFR-100 settings, including output voltage/current, the slew rate for voltage/current, Bleed circuit control, OCP, delayed time for output voltage and Buzzer settings.

D. BLEEDER CIRCUIT CONTROL

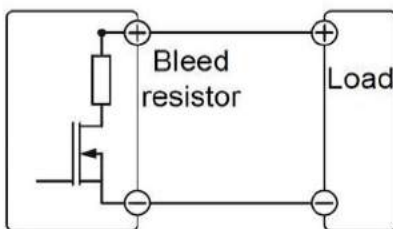

PFR-100 Series Bleeder Circuit

The PFR-100 series power supply has a bleeder circuit control which is in parallel with the output terminal. When power is off or load is disconnected, the bleed resistor will consume electricity from the filter capacitor. Without a bleed resistor, the filter capacitor of power could still be charged with electricity that poses a potential danger. In addition, for ATE system, bleed resistor allows the PFR-100 series to bleed current rapidly so as to prepare itself for the next operation.

E REMOTE PROGRAM CONTROL (UP TO 31 UNITS CONNECTION)

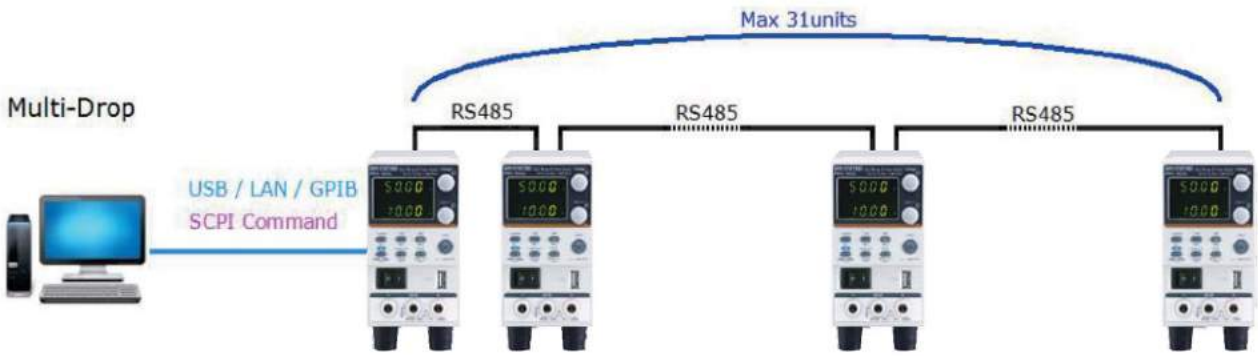

Provide USB, GPIB and LAN for PC to remote control Master PFR-100. RJ-45 connector on the rear panel can connect up to 31 units. LAN or USB remote control and augmenting slave

units by using the multi-drop mode will no longer need any switch/hub that can help customers save equipment costs.

F EXTERNAL ANALOG CONTROL FUNCTION

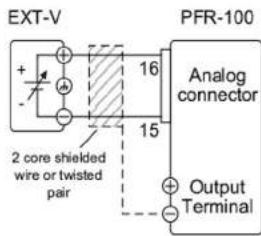

Pin16 → EXT-V (+)
Pin15 → EXT-V (-)
Wire shield → negative (-) output terminal

**External Voltage Controls
Voltage Range**

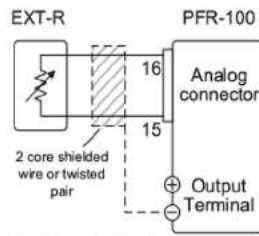

Pin16 → EXT-R
Pin15 → EXT-R
Wire shield → negative (-) output terminal

**External Resistance Controls
Voltage Range**

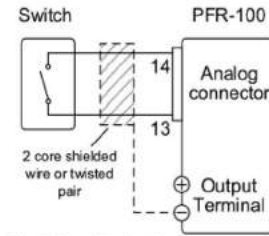

Pin14 → Switch
Pin13 → Switch
Wire shield → negative (-) output terminal

**External ON-OFF To Control
Output, ON or OFF**

The rear panel of the PFR-100 series has an analog control terminal. The external analog control interface allows external voltage or resistance to control voltage and current output; and allows power supply to output or to be turned on and off.

The diagram above shows typical connection methods for external control applications. For more detailed connection information please refer to user manual.

G OUTPUT ON/OFF DELAY

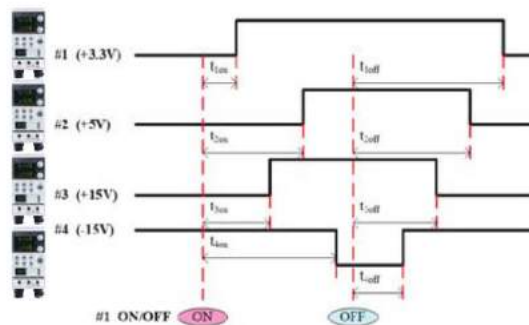

An Example of Output On/Off Delay Control Among Multiple Outputs of the PFR-100 units

The Output On/Off delay feature enables the setting of a specific time delay for output on after the power supply output is turned on, and a specific time delay for output off after the power supply output is turned off. When multiple PFR-100 units are used, the

On/Off delay time of each unit can be set respectively referring to fix time points. This multiple-output control can be done through the analog control terminal at rear panel or through the PC programming with standard commands.

Low Noise D.C. Power Supply



PLR 20-18/36-10/60-6



PLR 20-36/36-20/60-12



FEATURES

- * Output Voltage Rating : 20V/36V/60V
- * Output Power : 360W/720W
- * Low Ripple and Noise(0.5mVrms/10mArms)
- * Fast Transition Recovery Time(100μs)
- * Equipped Power Factor Correction Circuit for AC-input 100~240VAC
- * Maximum 2 units in Series Connections or 3 units in Parallel Connections
- * Select the Setting Digits for Voltage and Current(Coarse/Fine Volume Control)
- * Panel Lock Function/3 set of Preset Function
- * Output Off Timer Function(Range : 1 min to 1000 hours & 59mins)
- * CC Priority Function(Prevent Overshoot & Inrush Current)
- * Sequence Function of PC Editing (Max. : 1000 steps/Min. step Period : 50ms)
- * Protection : OVP, UVP, OCP, Remote Sensing(Terminal Open)
- * External Analog Control Function
- * PC Remote Interface : Standard : RS-232 ; Optional : GPIB/USB/LAN

GW Instek launches the new generation PLR-series programmable switching D.C. power supply. The single power output ranges are 360W and 720W. The series comprises 6 models and the voltage ranges are 20V, 36V and 60V. The PLR-series is a hybrid circuit design which incorporates front stage switching and rear stage linear architectures. The unique advantages of this design benefit from the combination of both switching and linear structures. The front stage switching structure can effectively reduce size and weight, and the rear stage linear structure can maintain lower ripple voltage, lower ripple current, and faster transient response.

The PLR-series features many functions, including three sets of user-defined Preset function; programmable automatic Output off timer function; programmable Sequence function; CV, CC priority activation functions (prevent overshoot and inrush current while output is turned on); External voltage and current output control and OVP, OCP and UVP functions. The above functions are built-in. Users do not have to pay for any extra costs.

The flexible allocation is one of the advantages of the PLR-series. For users require large output power, the PLR-series allows maximum 3 same model units in parallel connection to obtain larger output current, and maximum 2 same model units in series connection to obtain larger output voltage.

The PLR-series takes the consideration of the integration between its rack and other systems. Hence, the heat dissipation design adopts front air inlet and rear air outlet (there is no air outlet on the top, bottom, and on the both sides). The optional dedicated rack mount adapter (GRA-427) is for PLR-series to be rack mounted. Other equipment can be directly placed on top or under PLR-series to save rack space.

The PLR-series is equipped with RS-232 interface and also provides optional GPIB&USB (PLR-GU) and USB&LAN (PLR-LU). The program control of maximum 32 units can be realized by Local Bus no matter which interface is utilized. Additionally, the PLR-ARC interface not only provides external voltage and external resistance control but also meets the requirement of PLC control.

The PLR-series genuinely meets users' requirements of the new generation DC power supplies. The series, completely simplifying and expediting system development processes, is suitable for the R&D, design verification, and manufacturing of the semi-conductor equipment, automobile, component and communications industries.

SPECIFICATIONS

	PLR 20-18	PLR 20-36	PLR 36-10	PLR 36-20	PLR 60-6	PLR 60-12
OUTPUT RATING						
Voltage	0V ~ 20V	0V ~ 20V	0V ~ 36V	0V ~ 36V	0V ~ 60V	0V ~ 60V
Current	0 ~ 18A	0 ~ 36A	0 ~ 10A	0 ~ 20A	0 ~ 6A	0 ~ 12A
Power	360W	720W	360W	720W	360W	720W
REGULATION (CV)						
Load	3mA	3mA	3.8mA	3.8mA	5mA	5mA
Line	2mA	2mA	2.8mA	2.8mA	4mA	4mA
REGULATION (CC)						
Load	5mA	5mA	5mA	5mA	5mA	5mA
Line	5mA	10mA	1mA	5mA	1mA	5mA
 RIPPLE & NOISE (Noise Bandwidth=20MHZ ; Ripple Bandwidth = 1MHZ)						
CV p-p	30mVp-p	30mVp-p	30mVp-p	30mVp-p	30mVp-p	30mVp-p
CV rms	0.5mVrms	0.5mVrms	0.5mVrms	0.5mVrms	0.5mVrms	0.5mVrms
CC rms	10mArms	10mArms	5mArms	10mArms	5mArms	5mArms
 READBACK ACCURACY (23°C±5°C, after 30 mins warm-up)						
Voltage	± (0.1%rdg+2digits)		± (0.1%rdg+2digits)		± (0.1%rdg+2digits)	
Current	± (0.5%rdg+2digits)		± (0.5%rdg+2digits)		± (0.5%rdg+2digits)	
Power	± (0.7%rdg+1.5%F.S.)		± (0.7%rdg+1.5%F.S.)		± (0.7%rdg+1.5%F.S.)	
 SETTING ACCURACY (23°C±5°C, after 30 mins warm-up)						
Voltage	± (0.5%SET+0.5%F.S.)		± (0.5%SET+0.5%F.S.)		± (0.5%SET+0.5%F.S.)	
Current	± (1%SET+1%F.S.)		± (1%SET+1%F.S.)		± (1%SET+1%F.S.)	
 RESPONSE TIME						
Raise Time (Output voltage: 10%~90%FS)	50ms/50ms: No load/ Rated load		50ms/50ms: No load/ Rated load		50ms/50ms: No load/ Rated load	
Fall Time(Full load) (Output voltage: 90%~10%FS)	50ms		50ms		150ms	
Fall Time(No load) (Output voltage: 90%~10%FS)	250ms		250ms		600ms	
Load Transient Recover Time (Load change from 50 to 100%)	100 μs		100 μs		100 μs	
 SETTING RESOLUTION						
Voltage	10mV		10mV		10mV	
Current	10mA		10mA		10mA	
 MEASUREMENT RESOLUTION						
Voltage	10mV		10mV		10mV	
Current	10mA		10mA		10mA	
 SERIES AND PARALLEL CAPABILITY						
Parallel Operation	Up to 3 units		Up to 3 units		Up to 3 units	
Series Operation	Up to 2 units		Up to 2 units		Up to 2 units	



PLR-Series

Rear Panel



SPECIFICATIONS						
	PLR 20-18	PLR 20-36	PLR 36-10	PLR 36-20	PLR 60-6	PLR 60-12
PROTECTION FUNCTION						
OVP	Set range : 10% to 110% F.S. Set resolution: 10 times the minimum display resolution Activated when the output voltage exceeds the set OVP value : Hardware detection					
OCB	Set range : 5% to 110% F.S. Set resolution: 10 times of minimum display resolution Activated when the output current exceeds set OCB value : Software detection					
UVP	Set range : -1V to 110% F.S. Set resolution: 10 times the minimum display resolution Activated when the output voltage falls below the set UVP value : Software detection					
ENVIRONMENT CONDITION						
Operation Temp.	0°C ~ 40°C					
Storage Temp.	- 20°C ~ 60°C					
Operating Humidity	30% ~ 85% RH (No dew condensation)					
Storage Humidity	20% ~ 85% RH (No dew condensation)					
READ BACK TEMP. COEFFICIENT						
Voltage	±100ppm/°C					
Current	±100ppm/°C					
OTHER						
Power Consumption	570VA	1100VA	520VA	1050VA	510VA	1000VA
Power Factor	0.99	0.99	0.99	0.99	0.99	0.99
Cooling Method	Forced cooling : Fan speed proportionate to the temperature of the internal heat sink					
Power Source	Single-phase 100VAC to 240VAC, 50Hz to 60Hz					
Interface	Standard : RS-232C ; Optional : LAN/USB, GPIB/USB, External Analog Control					
Analog Control	Yes					
Dimension & Weight	PLR 20-18/PLR 36-10/PLR 60-6 : 139.5 (H) x 140(W) x 415.5(D); Approx. 5.2kg PLR 20-36/PLR 36-20/PLR 60-12 : 139.5 (H) x 210(W) x 415.5(D); Approx. 7.5kg					

ORDERING INFORMATION

PLR 20-18	0~20V/0~1.8A/360W Low Noise DC Power Supply
PLR 20-36	0~20V/0~3.6A/720W Low Noise DC Power Supply
PLR 36-10	0~36V/0~1.0A/360W Low Noise DC Power Supply
PLR 36-20	0~36V/0~2.0A/720W Low Noise DC Power Supply
PLR 60-6	0~60V/0~0.6A/360W Low Noise DC Power Supply
PLR 60-12	0~60V/0~1.2A/720W Low Noise DC Power Supply

ACCESSORIES :

User Manual(CD) x 1, Power Cable x 1, Rear Output Terminal Cover x 1, Bolt set x 1(Hexagon head bolt P-3 x 2, Flat washer x 2, Hexagon nut x 2), Output grounding cable x 1, M4 Small Screw Washer x 1, M3 Small Screw Washer x 1, M3 Large Screw Washer x 2

OPTIONAL ACCESSORIES

PLR-GU	GPIB/USB Interface Card
PLR-LU	LAN/USB Interface Card
PLR-ARC	External Analog Control Interface Card
PLR-001	Parallel Connection Signal Cable(2~3 units)
PLR-002	Series Connection Signal Cable
GRA-427	Rack Mount Kit (EIA+JIS)
GTL-246	USB Cable (1.2m)
GTL-248	GPIB Cable (2.0m)
GRJ-1101	Modular Cable (0.5m)
GRJ-1102	Modular Cable (1.5m)

Low Noise D.C. Power Supply

A. SERIES AND PARALLEL CONNECTIONS (Voltage and Current Allocation Chart for Series and Parallel Operation)

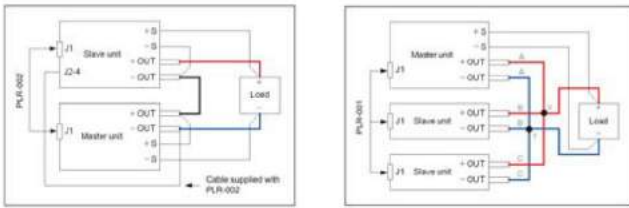

Series Connection Diagram Parallel Connection Diagram

To bring up the overall output power, the PLR-series supports same model units to be arranged in series operation for the maximum 2 units or in parallel operation for maximum 3 units.

Unit	Model	PLR 20-18	PLR 20-36	PLR 36-10	PLR 36-20	PLR 60-6	PLR 60-12
Single Unit	Voltage/Current Allocation	20V/18A	20V/36A	36V/10A	36V/20A	60V/6A	60V/12A
2 units in Series Operation	Voltage/Current Allocation	40V/18A	40V/36A	72V/10A	72V/20A	120V/6A	120V/12A
2 units in Paralle Operation	Voltage/Current Allocation	20V/36A	20V/72A	36V/20A	36V/40A	60V/12A	60V/24A
3 units in Paralle Operation	Voltage/Current Allocation	20V/54A	20V/108A	36V/30A	36V/60A	60V/18A	60V/36A

The series is very suitable for the power supply applications on D.C. power supply modules, electronic parts and components, and wafer plating equipment.

B. SEQUENCE FUNCTION

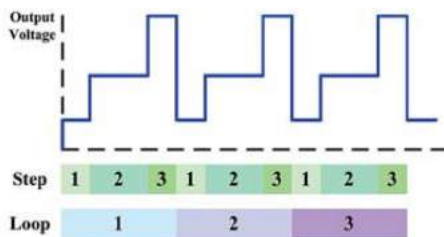

Example for the Sequence Operation

Before applying the sequence function, a series of different voltage, current and duration steps must be edited by a PC to make a sequence. CSV format, through RS-232C, LAN/USB (option) or GPIB/USB (option) interface, is transmitted to the memory of the PLR-series to sequentially execute steps consisting of voltage, current, and duration settings of the sequence. The shortest time for each step is 50ms and the maximum steps are 1000. The sequence function is to test DUT's response to the fast changing power supply that is one of the crucial verification items for electronic products' reliability tests.

C. PRESET FUNCTION



The PLR-series provides three parameter preset function keys on the front panel and each preset memory consists of parameters of output voltage and output current settings. Users via storing frequently used voltage and current parameters from the front panel to quickly save and recall parameters.

D. OUTPUT OFF TIMER FUNCTION



Counting Down From 2hr and 20mins

The output off timer function is to set the PLR-series to automatically turn off its output after a certain period of time. The shortest time setting is 1 minute. The setting range is from 1 minute to the maximum 1000 hours and 59 minutes. This function can only be activated when power supply output is being turned on.

E. OVP, OCP AND UVP FUNCTIONS

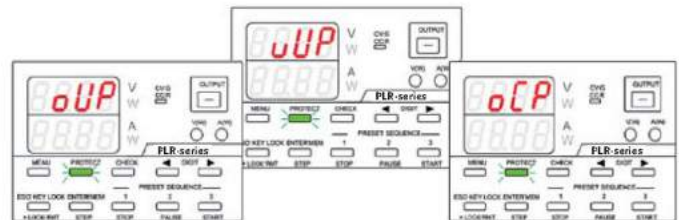

OVP (Over Voltage Protection) UVP (Under Voltage Protection) OCP (Over Current Protection)

When the voltage and current outputs exceed the preset conditions of OVP and OCP, the PLR-series will be shut down so as to prevent DUT from any damages.

OCP : the setting range is 5%~110% of the rated output
 OVP : the setting range is 10%~110% of the rated output
 UVP : the setting range is 1V ~ 110% of the rated output

F. EXTERNAL ANALOG CONTROL FUNCTION

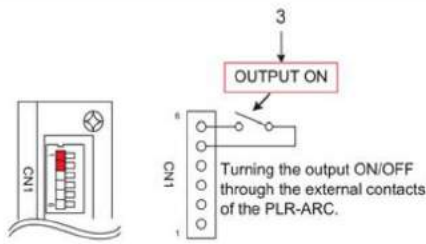

Turning the Output on by External Analog Control Interface

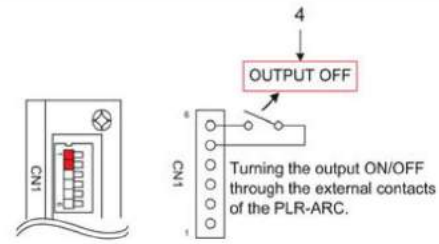

Turning the Output Off by External Analog Control Interface

The rear panel of the PLR-series features analog control terminal which controls output voltage and current values through external voltage or resistance. The on and off of power supply output or main power disconnection can also

be executed via external analog control interface. The above diagrams show the typical external analog control connection methods. For more connection information, please refer to the user manual.

G. COMPARISONS ON TRANSIENT RECOVERY TIME CHARACTERISTICS

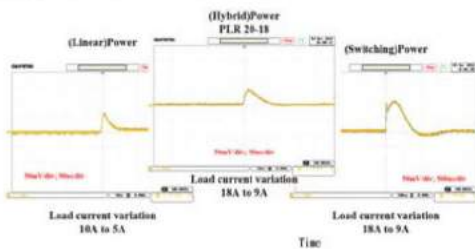

Comparison for Recovery Time ($V_o = 20V$)

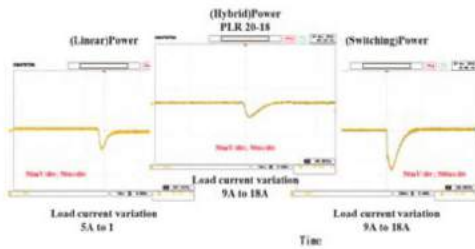

Comparison for Recovery Time ($V_o = 20V$)

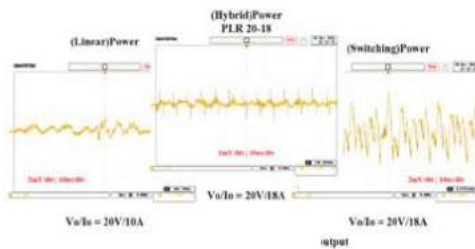

Ripple Comparison for Rating Power Output (Bandwidth : 1MHz) Ripple Comparison for Rating Power Output

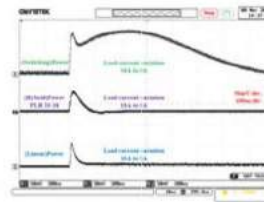

Current Falling Comparison

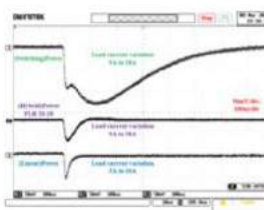

Current Rising Comparison

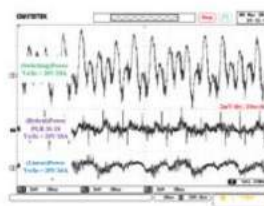

The PLR-series has a fast transient recovery capability, which is ideal for applications of large load current changes. The above diagrams show the actual comparative results of transient response time under different techniques.

H. FEATURE COMPARISONS

Operation	Linear Type Power Supply	PLR-series (Hybrid)	Switching Type Power Supply
Ripple & Noise for CV	0.35mVrms(Typ.)	≤ 0.5mVrms	7mVrms(Typ.)
Ripple & Noise for CC	< 2mArms(Typ.)	5mArms	72mArms(Typ.)
Recovery Time	< 50μs(Typ.)	≤ 100μs	1ms(Typ.)
Series & Parallel Operation	—	✓	✓
External Analog Control Interface	—	Opt.	Std.
Interfaces	Std. : RS-232/GPIB	Std. : RS-232/Local bus Opt. : LAN/USB or GPIB/USB	Std. : USB/LAN Opt. : USB to GPIB, USB to RS-232
Power	200W	360W	360W
Dimensions (mm)	230(W) × 140(H) × 380(D) △	140(W) × 124(H) × 364(D) ○	71(W) × 124(H) × 350(D) ◎
Weight	10 kg △	5.2 kg ○	3 kg ◎
CE Certificate	✓	✓	✓

◎ : Excellent
○ : Good
△ : Bad

Programmable Switching D.C. Power Supply (Multi-Range D.C. Power Supply)



PSW-Series



FEATURES

- * Voltage Rating : 30V/80V/160V/250V/800V, Output Power Rating : 360W~1080W
- * Multi-range Voltage & Current Combinations in One Power Supply
- * C.V/C.C Priority ; Particularly Suitable for the Battery and LED Industry
- * Adjustable Slew Rate
- * Series Operation(2 units in Series)for(30V/80V/160V), Parallel Operation(3 units in Parallel) for (30V/80V/160V/250V/800V)
- * High Efficiency and High Power Density
- * 1/2, 1/3, 1/6 Rack Mount Size Design (EIA/JIS Standard) for 360W, 720W, 1080W
- * Standard Interface : LAN, USB, Analog Control Interface
- * Optional Interface : GPIB-USB Adaptor, RS232-USB Cable
- * LabVIEW Driver



PSW 80-40.5 (0~80V, 0~40.5A, 1080W)



PSW 160-7.2 (0~160V, 0~7.2A, 360W)



PSW 80-13.5 (0~80V, 0~13.5A, 360W)

The PSW-Series is a single-output multi-range programmable switching DC Power Supply covering a power range up to 1080W. This series of products include fifteen models with the combination of 30V, 80V, 160V, 250V and 800V rated voltages and 360W, 720W and 1080W maximum output powers. The multi-range feature allows the flexible and efficient configuration of voltage and current within the rated power range. As the PSW-Series can be connected in series for maximum 2 units or in parallel for maximum 3 units, the capability of connecting multiple PSW-Series units for higher voltage or higher current output provides a broad coverage of applications. With the flexibility of multi-range power utilization and series/parallel connection, the PSW-Series significantly reduces the users' cost for various power supply products to accommodate the projects with different power requirements.

The C.V/C.C priority selection of the PSW-Series is a very useful feature for DUT protection. The conventional power supply normally operates under C.V mode when the power output is turned on. This could bring a high inrush current to the capacitive load or current-intensive load at the power output-on stage. Taking the I-V curve verification of LED as an example, it becomes a very challenging task to perform this measurement using a conventional power supply. With LED connected to a power supply under C.V mode as the initial setting, when the power output is turned on and the voltage rises to the LED forward voltage, the current will suddenly peak up and exceed the preset value of current limit. Upon detecting this high current, the power supply starts the transition from C.V mode to C.C mode. Though the current becomes stable after the C.C mode being activated, the current spike occurred at the C.V and C.C crossover point may possibly damage the DUT. At the power output-on stage, the PSW-Series is able to operate under C.C priority to limit the current spike occurred at the threshold voltage and therefore protects DUT from the inrush current damage.

The adjustable slew rate of the PSW-Series allows users to set for either output voltage or output current, a specific rise time from low to high level transition, and a specific fall time from high to low level transition. This facilitates the characteristic verification of a DUT during voltage or current level changes with controllable slew rates. Most manufacturing tests of lighting device or large capacitor during power output-on are associated with the occurrence of high surge current, which can greatly reduce the life time of the DUT. To prevent inrush current from damaging current-intensive devices, a smooth and slow voltage transition during power On-Off can significantly reduce the spike current and protect the device from high current damage.

The OVP and OCP are provided with the PSW-Series. Both OVP and OCP levels can be selected, with default level set at 110%, of the rated voltage/current of the power supply. When any of the protection levels is tripped, the power output will be switched off to protect the DUT. The PSW-Series provides USB Host/Device and LAN interfaces as standard, GPIB-USB adapter and RS232-USB cable as optional. The LabView driver and the Data Logging PC software are supported on all the available interfaces. An analog control/monitoring connector is also available on the rear panel for external control of power On/Off and external monitoring of power output Voltage and Current.

PARALLEL OPERATION (3 UNITS)

MODEL	SINGLE UNIT	2 UNITS	3 UNITS
PSW 30-36	30V/36A	30V/72A	30V/108A
PSW 30-72	30V/72A	30V/144A	30V/216A
PSW 30-108	30V/108A	30V/216A	30V/324A
PSW 80-13.5	80V/13.5A	80V/27A	80V/40.5A
PSW 80-27	80V/27A	80V/54A	80V/81A
PSW 80-40.5	80V/40.5A	80V/81A	80V/121.5A
PSW 160-7.2	160V/7.2A	160V/14.4A	160V/21.6A
PSW 160-14.4	160V/14.4A	160V/28.8A	160V/43.2A
PSW 160-21.6	160V/21.6A	160V/43.2A	160V/64.8A
PSW 250-4.5	250V/4.5A	250V/9A	250V/13.5A
PSW 250-9	250V/9A	250V/18A	250V/27A
PSW 250-13.5	250V/13.5A	250V/27A	250V/40.5A
PSW 800-1.44	800V/1.44A	800V/2.88A	800V/4.32A
PSW 800-2.88	800V/2.88A	800V/5.76A	800V/8.64A
PSW 800-4.32	800V/4.32A	800V/8.64A	800V/12.96A

SERIES OPERATION (2 UNITS)

MODEL	SINGLE UNIT	2 UNITS
PSW 30-36	30V/36A	60V/36A
PSW 30-72	30V/72A	60V/72A
PSW 30-108	30V/108A	60V/108A
PSW 80-13.5	80V/13.5A	160V/13.5A
PSW 80-27	80V/27A	160V/27A
PSW 80-40.5	80V/40.5A	160V/40.5A
PSW 160-7.2	160V/7.2A	320V/7.2A
PSW 160-14.4	160V/14.4A	320V/14.4A
PSW 160-21.6	160V/21.6A	320V/21.6A
PSW 250-4.5	N/A	N/A
PSW 250-9	N/A	N/A
PSW 250-13.5	N/A	N/A
PSW 800-1.44	N/A	N/A
PSW 800-2.88	N/A	N/A
PSW 800-4.32	N/A	N/A

PSW-Series

POWER SUPPLIES

SPECIFICATIONS									
	PSW 30-36	PSW 30-72	PSW 30-108	PSW 80-13.5	PSW 80-27	PSW 80-40.5	PSW 160-7.2	PSW 160-14.4	PSW 160-21.6
OUTPUT RATING									
Voltage	0 ~ 30V	0 ~ 30V	0 ~ 30V	0 ~ 80V	0 ~ 80V	0 ~ 80V	0 ~ 160V	0 ~ 160V	0 ~ 160V
Current	0 ~ 36A	0 ~ 72A	0 ~ 108A	0 ~ 13.5A	0 ~ 27A	0 ~ 40.5A	0 ~ 7.2A	0 ~ 14.4A	0 ~ 21.6A
Power	360W	720W	1080W	360W	720W	1080W	360W	720W	1080W
REGULATION(CV)									
Load Line	20mV 18mV	20mV 18mV	20mV 18mV	45mV 43mV	45mV 43mV	45mV 43mV	85mV 83mV	85mV 83mV	85mV 83mV
REGULATION(CC)									
Load Line	41mA 41mA	77mA 77mA	113mA 113mA	18.5mA 18.5mA	32mA 32mA	45.5mA 45.5mA	12.2mA 12.2mA	19.4mA 19.4mA	26.6mA 26.6mA
RIPPLE & NOISE (Noise Bandwidth 20MHz; Ripple Bandwidth=1MHz)									
CV p-p	60mV	80mV	100mV	60mV	80mV	100mV	60mV	80mV	100mV
CV rms	7mV	11mV	14mV	7mV	11mV	14mV	12mV	15mV	20mV
CC rms	72mA	144mA	216mA	27mA	54mA	81mA	15mA	30mA	45mA
PROGRAMMING ACCURACY									
Voltage	0.1% +10mV	0.1% +10mV	0.1% +10mV	0.1% +10mV	0.1% +10mV	0.1% +10mV	0.1% +100mV	0.1% +100mV	0.1% +100mV
Current	0.1% +30mA	0.1% +60mA	0.1% +100mA	0.1% +10mA	0.1% +30mA	0.1% +40mA	0.1% +5mA	0.1% +15mA	0.1% +20mA
MEASUREMENT ACCURACY									
Voltage	0.1% +10mV	0.1% +10mV	0.1% +10mV	0.1% +10mV	0.1% +10mV	0.1% +10mV	0.1% +100mV	0.1% +100mV	0.1% +100mV
Current	0.1% +30mA	0.1% +60mA	0.1% +100mA	0.1% +10mA	0.1% +30mA	0.1% +40mA	0.1% +5mA	0.1% +15mA	0.1% +20mA
RESPONSE TIME									
Raise Time	50ms	50ms	50ms	50ms	50ms	50ms	100ms	100ms	100ms
Fall Time(Full Load)	50ms	50ms	50ms	50ms	50ms	50ms	100ms	100ms	100ms
Fall Time(No Load)	500ms	500ms	500ms	500ms	500ms	500ms	1000ms	1000ms	1000ms
Load Transient Recover Time (Load change from 50~100%)	1ms	1ms	1ms	1ms	1ms	1ms	2ms	2ms	2ms
PROGRAMMING RESOLUTION (By PC Remote Control Mode)									
Voltage	1mV	1mV	1mV	2mV	2mV	2mV	3mV	3mV	3mV
Current	1mA	2mA	3mA	1mA	2mA	3mA	1mA	2mA	3mA
MEASUREMENT RESOLUTION (By PC Remote Control Mode)									
Voltage	1mV	1mV	1mV	2mV	2mV	2mV	3mV	3mV	3mV
Current	1mA	2mA	3mA	1mA	2mA	3mA	1mA	2mA	3mA
SERIES AND PARALLEL CAPABILITY									
Parallel Operation	Up to 3 units including the master unit								
Series Operation	Up to 2 units including the master unit								
PROTECTION FUNCTION									
OVP	3 ~ 33V	3 ~ 33V	3 ~ 33V	8 ~ 88V	8 ~ 88V	8 ~ 88V	16 ~ 176V	16 ~ 176V	16 ~ 176V
OCP	3.6 ~ 39.6A	5 ~ 79.2A	5 ~ 118.8A	1.35 ~ 14.85A	2.7 ~ 29.7A	4.05 ~ 44.55A	0.72 ~ 7.92A	1.44 ~ 15.84A	2.16 ~ 23.76A
OHP	Activated by elevated internal temperatures								
FRONT PANEL DISPLAY ACCURACY, 4 digits									
Voltage	0.1%±20mV	0.1%±20mV	0.1%±20mV	0.1%±20mV	0.1%±20mV	0.1%±20mV	0.1%±100mV	0.1%±100mV	0.1%±100mV
Current	0.1%±40mA	0.1%±70mA	0.1%±100mA	0.1%±20mA	0.1%±40mA	0.1%±50mA	0.1%±5mA	0.1%±30mA	0.1%±30mA
ENVIRONMENT CONDITION									
Operation Temp	0°C ~ 50°C								
Storage Temp	-25°C ~ 70°C								
Operating Humidity	20% ~ 85% RH; No condensation								
Storage Humidity	90% RH or Less; No condensation								
READ BACK TEMP COEFFICIENT									
Voltage	100ppm/°C of rated output voltage : after a 30 minute warm-up								
Current	200ppm/°C of rated output current : after a 30 minute warm-up								
OTHER									
Analog Control Interface	Yes USB/LAN/GPIB-USB(Optional)/RS232-USB(Optional)								
Fan	With thermal sensing control								
POWER SOURCE	85VAC~265VAC, 47~63Hz, single phase								
DIMENSIONS & WEIGHT	71(W)x124(H)x350(D) mm ; Approx. 3kg	142(W)x124(H)x350(D) mm ; Approx. 5.3kg	214(W)x124(H)x350(D) mm ; Approx. 7.5kg	71(W)x124(H)x350(D) mm ; Approx. 3kg	142(W)x124(H)x350(D) mm ; Approx. 5.3kg	214(W)x124(H)x350(D) mm ; Approx. 7.5kg	71(W)x124(H)x350(D) mm ; Approx. 3kg	142(W)x124(H)x350(D) mm ; Approx. 5.3kg	214(W)x124(H)x350(D) mm ; Approx. 7.5kg

PSW-001 Accessory Kit



PSW-002 Simple IDC Tool



PSW-003 Contact Removal Tool



PSW-004 Basic Accessories Kit x 1 (for PSW 30V/80V/160V)



Programmable Switching D.C. Power Supply (Multi-Range D.C. Power Supply)

SPECIFICATIONS						
	PSW 250-4.5	PSW 250-9	PSW 250-13.5	PSW 800-1.44	PSW 800-2.88	PSW 800-4.32
OUTPUT RATING						
Voltage	0 ~ 250V	0 ~ 250V	0 ~ 250V	0 ~ 800V	0 ~ 800V	0 ~ 800V
Current	0 ~ 4.5A	0 ~ 9A	0 ~ 13.5A	0 ~ 1.44A	0 ~ 2.88A	0 ~ 4.32A
Power	360W	720W	1080W	360W	720W	1080W
REGULATION(CV)						
Load	130mV	130mV	130mV	405mV	405mV	405mV
Line	128mV	128mV	128mV	403mV	403mV	403mV
REGULATION(CC)						
Load	9.5mA	14mA	18.5mA	6.44mA	7.88mA	9.32mA
Line	9.5mA	14mA	18.5mA	6.44mA	7.88mA	9.32mA
RIPPLE & NOISE (Noise Bandwidth 20MHz; Ripple Bandwidth=1MHz)						
CV p-p	80mV	100mV	120mV	150mV	200mV	200mV
CV rms	15mV	15mV	15mV	30mV	30mV	30mV
CC rms	10mA	20mA	30mA	5mA	10mA	15mA
PROGRAMMING ACCURACY						
Voltage	0.1%+200mV	0.1%+200mV	0.1%+200mV	0.1%+400mV	0.1%+400mV	0.1%+400mV
Current	0.1%+5mA	0.1%+10mA	0.1%+15mA	0.1%+2mA	0.1%+4mA	0.1%+6mA
MEASUREMENT ACCURACY						
Voltage	0.1%+200mV	0.1%+200mV	0.1%+200mV	0.1%+400mV	0.1%+400mV	0.1%+400mV
Current	0.1%+5mA	0.1%+10mA	0.1%+15mA	0.1%+2mA	0.1%+4mA	0.1%+6mA
RESPONSE TIME						
Raise Time	100ms	100ms	100ms	150ms	150ms	150ms
Fall Time(Full Load)	150ms	150ms	150ms	300ms	300ms	300ms
Fall Time(No Load)	1200ms	1200ms	1200ms	2000ms	2000ms	2000ms
Load Transient Recover Time (Load change from 50~100%)	2ms	2ms	2ms	2ms	2ms	2ms
PROGRAMMING RESOLUTION (By PC Remote Control Mode)						
Voltage	5mV	5mV	5mV	14mV	14mV	14mV
Current	1mA	1mA	1mA	1mA	1mA	1mA
MEASUREMENT RESOLUTION (By PC Remote Control Mode)						
Voltage	5mV	5mV	5mV	14mV	14mV	14mV
Current	1mA	1mA	1mA	1mA	1mA	1mA
SERIES AND PARALLEL CAPABILITY						
Parallel Operation	3	3	3	3	3	3
Series Operation	N/A	N/A	N/A	N/A	N/A	N/A
PROTECTION FUNCTION						
OVP	20 ~ 275V	20 ~ 275V	20 ~ 275V	20 ~ 880V	20 ~ 880V	20 ~ 880V
OCP	0.45 ~ 4.95A	0.9 ~ 9.9A	1.35 ~ 14.85A	0.144 ~ 1.584A	0.288 ~ 3.168A	0.432 ~ 4.752A
OHP	Activated by elevated internal temperatures					
FRONT PANEL DISPLAY ACCURACY (4 digits)						
Voltage	0.1%±200mV	0.1%±200mV	0.1%±200mV	0.1%±400mV	0.1%±400mV	0.1%±400mV
Current	0.1%±5mA	0.1%±10mA	0.1%±20mA	0.1%±2mA	0.1%±4mA	0.1%±6mA
ENVIRONMENT CONDITION						
Operation Temp	0°C ~ 50°C					
Storage Temp	-25°C ~ 70°C					
Operating Humidity	20% ~ 85% RH; No condensation					
Storage Humidity	90% RH or Less; No condensation					
READ BACK TEMP COEFFICIENT						
Voltage	100ppm/°C of rated output voltage : after a 30 minute warm-up					
Current	200ppm/°C of rated output current : after a 30 minute warm-up					
OTHER						
Analog Control Interface	Yes USB/LAN/GPIB (Option) With thermal sensing control					
Fan	With thermal sensing control					
POWER SOURCE	85VAC~265VAC, 47~63Hz, single phase					
DIMENSIONS & WEIGHT	71 (W)x124 (H) x350 (D) mm ; Approx. 3kg	142 (W)x124 (H) x350 (D) mm ; Approx. 5.3kg	214 (W)x124 (H) x350 (D) mm ; Approx. 7.5kg	71 (W)x124 (H) x350 (D) mm ; Approx. 3kg	142 (W)x124 (H) x350 (D) mm ; Approx. 5.3kg	214 (W)x124 (H) x350 (D) mm ; Approx. 7.5kg

PSW-005 Cable for 2 Units of PSW-Series in Series Mode Connection (for PSW 30V/80V/160V)



PSW-006 Cable for 2 Units of PSW-Series in Parallel Mode Connection



PSW-007 Cable for 3 Units of PSW-Series in Parallel Mode Connection



PSW-008 Basic Accessories Kit (for PSW 250V/800V)





PSW-Series

ORDERING INFORMATION

PSW 30-36	(0-30V/0-36A/360W) Multi-Range DC Power Supply
PSW 30-72	(0-30V/0-72A/720W) Multi-Range DC Power Supply
PSW 30-108	(0-30V/0-108A/1080W) Multi-Range DC Power Supply
PSW 80-13.5	(0-80V/0-13.5A/360W) Multi-Range DC Power Supply
PSW 80-27	(0-80V/0-27A/720W) Multi-Range DC Power Supply
PSW 80-40.5	(0-80V/0-40.5A/1080W) Multi-Range DC Power Supply
PSW 160-7.2	(0-160V/0-7.2A/360W) Multi-Range DC Power Supply
PSW 160-14.4	(0-160V/0-14.4A/720W) Multi-Range DC Power Supply
PSW 160-21.6	(0-160V/0-21.6A/1080W) Multi-Range DC Power Supply
PSW 250-4.5	(0-250V/0-4.5A/360W) Multi-Range DC Power Supply
PSW 250-9	(0-250V/0-9A/720W) Multi-Range DC Power Supply
PSW 250-13.5	(0-250V/0-13.5A/1080W) Multi-Range DC Power Supply
PSW 800-1.44	(0-800V/0-1.44A/360W) Multi-Range DC Power Supply
PSW 800-2.88	(0-800V/0-2.88A/720W) Multi-Range DC Power Supply
PSW 800-4.32	(0-800V/0-4.32A/1080W) Multi-Range DC Power Supply

ACCESSORIES

CD-ROM x 1 (Programming Manual, User Manual), GTL-123 Test Lead x 1 (for PSW 30V/80V/160V), Power Cord x 1 (Region dependent), GTL-240 USB Cable " L " Type x 1, PSW-004 Basic Accessories Kit x 1 (for PSW 30V/80V/160V), Includes : M4 Terminal screws and washers x 2, Air Filter x 1, Analog control protection dummy x 1, Analog control lock lever x 1, M8 terminal bolts, nuts and washers x 2,

PSW-008 Basic Accessories kit for PSW 250V/800V models

PSW-009 Output terminal cover for 30V/80V/160V models

PSW-011 Output terminal cover for 250V/800V models

PSW-012 High voltage output terminal for 250V/800V model

OPTIONAL ACCESSORIES

PSW-001 Accessory Kit

PSW-002 Simple IDC Tool

PSW-003 Contact Removal Tool

PSW-005 Cable for 2 Units of PSW-Series in Series Mode Connection (for PSW 30V/80V/160V)

PSW-006 Cable for 2 Units of PSW-Series in Parallel Mode Connection

PSW-007 Cable for 3 Units of PSW-Series in Parallel Mode Connection

GUG-001 GPIB to USB Adaptor

GRA-410-J Rack Mount Kit (JIS)

GRA-410-E Rack Mount Kit (EIA)

GET-001 Extended Terminal (for PSW 30V/80V/160V)

GET-002 Extended Terminal (for PSW 250V/800V)

GTL-130 Test lead : 2 x red, 2 x black (for PSW 250V/800V)

PSW-010 Large filter (Type II/III)

GTL-248 GPIB Cable, Double Shielded, 2000mm

GTL-250 GPIB Cable, Double Shielded, 600mm

CUR-001 USB to RS-232 Cable, 300mm

PSW-Series (LV) Rear Panel



PSW-Series (HV) Rear Panel



GUR-001 USB to RS-232 Cable (for PSW-Series, 300mm)



GUG-001 GPIB to USB Adaptor (for GDS-3000Series, PSW-Series)



GET-001 Extended Terminal (for PSW 30V/80V/160V)



GET-002 Extended Terminal (for PSW 250V/800V)



GTL-130 Test lead, 1200mm, 18AWG, UL 3239 (for PSW 250V/800V)



Programmable Switching D.C. Power Supply



GW Instek PSU-HV series has five models, including PSU 100-15, PSU 150-10, PSU 300-5, PSU 400-3.8, and PSU 600-2.6. The launch of PSU-HV is to complete the existing PSU series so as to satisfy high voltage application demands, allowing the augmented PSU-series to cover a voltage range from 6V to 600V. PSU-HV inherits the functional design and maintains the high power density characteristic and 1U height appearance of the PSU-LV series (PSU 6-200, PSU 12.5-120, PSU 20-76, PSU 40-38 and PSU 60-25). Furthermore, the original maximum output voltage of 60V is expanded to the maximum voltage of 600V and the maximum power of 1560 watts. The launch of the PSU-HV series augments the existing PSU-series to fully satisfy the extensive voltage demands of 1U power supply market and provides system integrators with more flexibilities and selections to conduct system integration. The introduction of the PSU-HV series has perfected the PSU product line, which satisfies the application requirements ranging from low voltage and large current to high voltage.

PSU-Series



FEATURES

- * Voltage Output : 6V/12.5V/20V/40V/60V/100V/150V/300V/400V/600V
- * Power Output : 1200W ~ 1560W
- * C.V/C.C Priority Mode
- * Adjustable Voltage/Current Rise and Fall Time
- * Series/Parallel Connection : Max. 2 units (Models Under 300V)/4 units of The Same Model
- * High Efficiency and High Power Density
- * 1U Height and 19" Rack Mount Size
- * Three sets of Preset Function
- * Bleeder Control Function
- * Internal Resistance Function
- * Panel Lock Function
- * Protection : OVP, OCP, OHP, UVL, AC Fail, FAN Fail
- * Standard : USB, LAN, RS-232, RS-485, Analog Control
- * Option : GPIB, Isolated Analog Interface (Voltage Control/Current Control)

Utilizing same model units of the PSU-series to conduct series and parallel connections can increase total output power, total current or total voltage. The wide voltage and current output ranges of the PSU-series can fully satisfy various voltage and current measurement requirements. The PSU-series is a single power output DC programmable power supply, which outputs 1200W to 1560W. The PSU-series provides maximum 2 units in series connection (models under 300V) to achieve maximum 600V or 4 units in parallel connection to obtain maximum 800A and the maximum output power of 6.24 kilowatts.

The PSU-series allows settings for CC priority or CV priority. Under CC or CV mode, users can adjust slew rate for output voltage or current based upon test requirements. There are two kinds of slew rate settings: high speed priority and slew rate priority. High speed priority sets slew rate at the maximum speed to reach CC or CV mode. Slew rate priority allows users to set slew rate for CC or CV mode in order to control rise or fall slew rate. Slew rate priority mode is ideal for motor tests by adjusting the rise time of output voltage to protect DUT from being damaged by inrush current occurred at turn-on.

Comparing with other 1U power supplies available in the market, PSU supports a most complete array of interfaces, including USB, LAN, RS-232, RS-485, analog control interface, GPIB (option), isolated analog interface (voltage control), and isolated analog interface (current control). Via the multi-drop mode, PSU will not need any switch/hub and GPIB cable for remote control and slave unit augmentation when using LAN, USB or GPIB. This feature can help users save costs on augmentation equipment for connecting slave while using LAN or USB.

The new PSU-HV series is ideal for the primary input of DC/DC converter and servomotor production application. PSU is often integrated into component test systems such as aging test equipment for capacitors; 600V DC bias applications; aging test equipment for diode; semiconductor production equipment; automotive electronics; and ECU for V8 engine or V12 engine, etc.

The PSU-series provides users with flexible settings of High/Low Level or Trigger input /Trigger output signals with pulse width of 1 ~ 60ms. Trigger input controls PSU to output or upload preset voltage, current and memory parameters. While outputting or uploading preset voltage, current and memory parameters PSU can produce corresponding Trigger output signals.

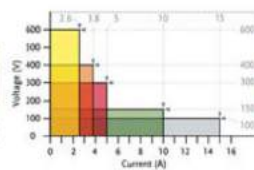
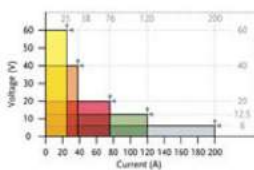

Model name	Voltage Rating	Current Rating	Power
PSU 6-200	6V	200A	1200W
PSU 12.5-120	12.5V	120A	1500W
PSU 20-76	20V	76A	1520W
PSU 40-38	40V	38A	1520W
PSU 60-25	60V	25A	1500W
PSU 100-15	100V	15A	1500W
PSU 150-10	150V	10A	1500W
PSU 300-5	300V	5A	1500W
PSU 400-3.8	400V	3.8A	1520W
PSU 600-2.6	600V	2.6A	1560W

1U Handle & Bracket



- Note :
- *1. Minimum voltage is guaranteed to maximum 0.2% of the rated output voltage.
 - *2. Minimum current is guaranteed to maximum 0.4% of the rated output current.
 - *3. At 85~132Vac or 170~265Vac, constant load.
 - *4. From No-load to Full-load, constant input voltage.
Measured at the sensing point in Remote Sense.
 - *5. Measure with JEITA RC-9131B (1:1) probe.
 - *6. Measurement frequency bandwidth is 10Hz~20MHz.
 - *7. Measurement frequency bandwidth is 5Hz~1MHz.
 - *8. From 10%~90% of rated output voltage, with rated resistive load.
 - *9. From 90%~10% of rated output voltage, with rated resistive load.
 - *10. Time for output voltage to recover within 0.5% of its rated output for a load change from 10~90% of its rated output current. Voltage set point from 10%~100% of rated output.
 - *11. For load voltage change, equal to the unit voltage rating, constant input voltage.
 - *12. For 6V model the ripple is measured at 2~6V output voltage and full output current.
For other models, the ripple is measured at 10~100% output voltage and full output current.
 - *13. At rated output power.

SPECIFICATIONS										
MODEL	PSU 6-200	PSU 12.5-120	PSU 20-76	PSU 40-38	PSU 60-25	PSU 100-15	PSU 150-10	PSU 300-5	PSU 400-3.8	PSU 600-2.6
OUTPUT RATINGS										
Rated Output Voltage (*1)	6V	12.5V	20V	40V	60V	100V	150V	300V	400V	600V
Rated Output Current (*2)	200A	120A	76A	38A	25A	15A	10A	5A	3.8A	2.6A
Rated Output Power	1200W	1500W	1520W	1520W	1500W	1500W	1500W	1500W	1520W	1560W
RIPPLE AND NOISE(*5)										
CVp-p(10 ~ 20MHz) p-p (*6)	60mV	60mV	60mV	60mV	60mV	80mV	100mV	150mV	200mV	300mV
CVrms(5Hz ~ 1MHz) r.m.s. (*7)	8mV	8mV	8mV	8mV	8mV	8mV	10mV	25mV	40mV	60mV
CCrms(5Hz ~ 1MHz) r.m.s. (*12)	400mA	240mA	152mA	95mA	75mA	45mA	35mA	25mA	17mA	12mA
LOAD REGULATION										
Voltage(*4)	2.6mV	3.25mV	4mV	6mV	8mV	12mV	17mV	32mV	42mV	62mV
Current(*11)	45mA	29mA	20.2mA	12.6mA	10mA	8mA	7mA	6mA	5.76mA	5.52mA
LINE REGULATION										
Voltage(*3)	2.6mV	3.25mV	4mV	6mV	8mV	12mV	17mV	32mV	42mV	62mV
Current(*3)	22mA	14mA	9.6mA	5.8mA	4.5mA	3.5mA	3mA	2.5mA	2.38mA	2.26mA
ANALOG PROGRAMMING AND MONITORING										
External Voltage Control Output Voltage	Accuracy and linearity: ±0.5% of rated output voltage									
External Voltage Control Output Current	Accuracy and linearity: ±1% of rated output current									
External Resistor Control Output Voltage	Accuracy and linearity: ±1% of rated output voltage									
External Resistor Control Output Current	Accuracy and linearity: ±1.5% of rated output current									
Output Voltage Monitor	Accuracy: ±1%									
Output Current Monitor	Accuracy: ±1%									
Shutdown Control	Turns the output off with a LOW (0V to 0.5V) or short-circuit									
Output On/Off Control	Possible logic selections: Turn the output on using a LOW (0V to 0.5V) or short-circuit, turn the output off using a HIGH (4.5V to 5V) or open-circuit; Turn the output on using a HIGH (4.5V to 5V) or open-circuit, turn the output off using a LOW (0V to 0.5V) or short-circuit									
Alarm Clear Control	Clear alarms with a LOW (0V to 0.5V) or short-circuit									
CV/CC/ALM/PWR ON/OUT ON Indicator	Photocoupler open collector output; Maximum voltage 30V, maximum sink current 8mA									
Trigger Out	Maximum low level output = 0.8V; minimum high level output = 2V; Maximum source current = 8mA									
Trigger In	Maximum low level input voltage = 0.8V; minimum high level input voltage = 2V, Maximum sink current = 8mA									
FRONT PANEL										
Display, 4 digits, Voltage Accuracy 0.1%+ Current Accuracy 0.2%+	12mV 600mA	25mV 360mA	40mV 228mA	80mV 114mA	120mV 75mA	200mV 45mA	300mV 30mA	600mV 15mA	800mV 11.4mA	1200mV 7.8mA
Indications	GREEN LED's: CV, CC, V, A, VSR, ISR, DLY, RMT, LAN, M1, M2, M3, RUN, Output ON; RED LED's: ALM, ERR									
Buttons	Lock/Local (Unlock), PROT(ALM_CLR), Function(M1), Test(M2), Set(M3), Shift, Output									
Knobs	Voltage, Current									
USB Port	Type A USB connector									
Transient Response Time	1.5ms	1ms	1ms	1ms	1ms	1ms	2ms	2ms	2ms	2ms
OUTPUT RESPONSE TIME										
Rise Time(*8)	Rated load 80ms	80ms	80ms	80ms	80ms	80ms	150ms	150ms	150ms	200ms
	No load	80ms	80ms	80ms	80ms	80ms	150ms	150ms	150ms	200ms
Fall Time(*9)	Rated load 10ms	50ms	50ms	80ms	80ms	80ms	150ms	150ms	150ms	200ms
	No load	500ms	700ms	800ms	1000ms	1100ms	1500ms	2000ms	2500ms	4000ms
PROGRAMMING AND MEASUREMENTS (RS-232/485, USB, LAN, GPIB)										
Output Voltage Programming Accuracy	0.05%+	3mV	6.25mV	10mV	20mV	30mV	50mV	75mV	150mV	200mV
Output Current Programming Accuracy	0.2%+	200mA	120mA	76mA	38mA	25mA	15mA	10mA	5mA	3.8mA
Output Voltage Programming Resolution		0.2mV	0.4mV	0.7mV	1.3mV	2mV	3.4mV	5.2mV	10.2mV	13.6mV
Output Current Programming Resolution		6mA	4mA	2.5mA	1.2mA	0.8mA	0.5mA	0.34mA	0.19mA	0.13mA
Output Voltage Measurement Accuracy	0.1%+	6mV	12.5mV	20mV	40mV	60mV	100mV	150mV	300mV	400mV
Output Current Measurement Accuracy	0.2%+	400mA	240mA	152mA	76mA	50mA	30mA	20mA	10mA	7.6mA
Output Voltage Measurement Resolution		0.2mV	0.4mV	0.7mV	1.3mV	2mV	3.4mV	5.2mV	10.2mV	13.6mV
Output Current Measurement Resolution		6mA	4mA	2.5mA	1.2mA	0.8mA	0.5mA	0.34mA	0.19mA	0.13mA
TEMPERATURE COEFFICIENCY										
Voltage & Current	100ppm/°C after a 30 minute warm-up									
REMOTE SENSE COMPENSATION VOLTAGE(SINGLE WIRE)										
Voltage	1V	1V	1V	2V	3V	5V	5V	5V	5V	5V
PROTECTION FUNCTION										
Over Voltage Protection(OVP)	Setting Range 60mV	0.6~6.6V 1.25~13.75V	2~22V 125mV	4~44V 200mV	5~66V 400mV	5~110V 600mV	5~165V 1000mV	5~330V 3000mV	5~440V 4000mV	5~660V 6000mV
Over Current Protection(OCP)	Setting Range Setting Accuracy	5~220A 4000mA	5~132A 2400mA	5~83.6A 1520mA	3.8~41.8A 760mA	2.5~27.5A 500mA	1.5~16.5A 300mA	1~11A 200mA	0.5~5.5A 100mA	0.38~4.18A 76mA
Under Voltage Limit(UVL)	Setting Range	0~6.3V	0~13.12V	0~21V	0~42V	0~63V	0~105V	0~157.5V	0~315V	0~420V
Over Temperature Protection(OHP)	Operation	Turn the output off.								
Incorrect Sensing Connection Protection(SENSE)	Operation	Turn the output off.								
Low AC Input Protection (AC-FAIL)	Operation	Turn the output off.								
Shutdown (SD)	Operation	Turn the output off.								
Power Limit (POWER LIMIT)	Operation Value (Fixed)	Over power limit Approx. 105% of rated output power								
INTERFACE CAPABILITIES										
USB	TypeA: Host, TypeB: Slave, Speed: 1.1/2.0, USB Class: CDC(Communications Device Class)									
LAN	MAC Address, DNS IP Address, User Password, Gateway IP Address, Instrument IP Address, Subnet Mask									
RS-232 / RS-485	Complies with the EIA232D / EIA485 Specifications									
GPIB (Factory Option)	SCPI - 1993, IEEE 488.2 compliant interface									
ISOLATED ANALOG CONTROL INTERFACE (FACTORY OPTION)										
Voltage Control	Using 0-5V or 0-10V signals for programming and measurement									
Current Control	Using 4-20mA current signals for programming and measurement									
ENVIRONMENTAL CONDITIONS										
Operating Temperature	0°C ~ 50°C									
Storage Temperature	-25°C ~ 70°C									
Operating Humidity	20% ~ 85% RH; No condensation									
Storage Humidity	90% RH or less; No condensation									
Altitude	Maximum 2000m									
INPUT CHARACTERISTICS										
Nominal Input Rating	100Vac to 240Vac, 50Hz to 60Hz, single phase									
Input Voltage Range	85Vac ~ 265Vac									
Input Frequency Range	47Hz ~ 63Hz									
Maximum Input Current	100Vac/200Vac(A)	21/11								
Inrush Current	Less than 50A									
Maximum Input Power	2000VA									
Power Factor	100Vac/200Vac	0.99/0.98								
Hold-up Time	20ms or greater									
Efficiency (*13)	100Vac/200Vac(%)	76.5/78.5	82.0/85.0	83.0/86.0	84.0/87.0	84.0/87.0	84.0/87.0	84.0/87.0	84.0/87.0	84.0/87.0
DIMENSIONS & WEIGHT										
423(W) × 43.6(H) × 447.2(D)mm, Approx. 8.7kg										

Programmable Switching D.C. Power Supply

Rear Panel



PSU-Series

ORDERING INFORMATION

PSU 6-200	1200W Programmable Switching DC Power Supply
PSU 12.5-120	1500W Programmable Switching DC Power Supply
PSU 20-76	1520W Programmable Switching DC Power Supply
PSU 40-38	1520W Programmable Switching DC Power Supply
PSU 60-25	1500W Programmable Switching DC Power Supply
PSU 100-15	1500W Programmable Switching DC Power Supply
PSU 150-10	1500W Programmable Switching DC Power Supply
PSU 300-5	1500W Programmable Switching DC Power Supply
PSU 400-3.8	1520W Programmable Switching DC Power Supply
PSU 600-2.6	1560W Programmable Switching DC Power Supply

ACCESSORIES :

CD-ROM x 1 (User Manual, Programming Manual), Output terminal cover x 1, Analog connector plug kit x 1, Output terminal M8 bolt set(6V~60V model), Input terminal cover x 1, 1U Handle(RoHS), 1U Bracket(LEFT, RoHS), 1U Bracket (RIGHT,RoHS), Power Cord(10A) x 1

OPTIONAL ACCESSORIES

PSU-01B	Bus bar for 2 units in parallel connection	GTL-246	USB Cable, USB 2.0A-B Type Cable, 4P
PSU-01C	Cable for 2 units in parallel connection	GRM-001	Slide bracket 2pcs/set ,PSU option
PSU-02B	Bus bar for 3 units in parallel connection	PSU-GPIB	GPIB Interface card (factory option)
PSU-02C	Cable for 3 units in parallel connection	GPW-001	UL/CSA power cord 3m ,PSU option
PSU-03B	Bus bar for 4 units in parallel connection	GPW-002	VDE power cord 3m ,PSU option
PSU-03C	Cable for 4 units in parallel connection	GPW-003	PSE power cord 3m ,PSU option
PSU-232	RS232 Cable with DB9 connector kit	PSU-ISO-I	Isolate current remote control card(factory option)
PSU-485	RS485 Cable with DB9 connector kit	PSU-ISO-V	Isolate voltage remote control card(factory option)
PSU-01A	Joins a vertical stack of 2 PSU units together. 2U-sized handles x2, joining plates x2		
PSU-02A	Joins a vertical stack of 3 PSU units together. 3U-sized handles x2, joining plates x2		
PSU-03A	Joins a vertical stack of 4 PSU units together. 4U-sized handles x2, joining plates x2		

FREE DOWNLOAD

Driver LabView Driver

PSU-01B

Bus bar for 2 units in parallel connection



PSU-232

Rs232 Cable with DB9 connector kit



PSU-02C

Cable for 3 units in parallel connection



GPW-001

UL/CSA power cord 3m, PSU option



PSU-01A

Joins a vertical stack of 2 PSU units together. 2U-sized handles x2, joining plates x2



PSU-01C

Cable for 2 units in parallel connection



PSU-485

Rs485 Cable with DB9 connector kit



PSU-03B

Bus bar for 4 units in parallel connection



GPW-002

VDE power cord 3m, PSU option



PSU-02A

Joins a vertical stack of 3 PSU units together. 3U-sized handles x2, joining plates x2



PSU-02B

Bus bar for 3 units in parallel connection



GRM-001

Slide bracket 2pcs/set, PSU option



PSU-03C

Cable for 4 units in parallel connection



GPW-003

PSE power cord 3m, PSU option



PSU-03A

Joins a vertical stack of 4 PSU units together. 4U-sized handles x2, joining plates x2



PSU-Series

POWER SUPPLIES

A. SERIES/PARALLEL OPERATION AND HIGH POWER DENSITY

Series Connection	1 unit	2 units	Parallel connection	1 unit	2 units	3 units	4 units
Height of Sets	1U	2U	Height of Sets	1U	2U	3U	4U
PSU 6-200	6V 200A	12V 200A	PSU 6-200	6V 200A	6V 400A	6V 600A	6V 800A
PSU 12.5-120	12.5V 120A	25V 120A	PSU 12.5-120	12.5V 120A	12.5V 240A	12.5V 360A	12.5V 480A
PSU 20-76	20V 76A	40V 76A	PSU 20-76	20V 76A	20V 152A	20V 228A	20V 304A
PSU 40-38	40V 38A	80V 38A	PSU 40-38	40V 38A	40V 76A	40V 114A	40V 152A
PSU 60-25	60V 25A	120V 25A	PSU 60-25	60V 25A	60V 50A	60V 75A	60V 100A
PSU 100-15	100V 15A	200V 15A	PSU 100-15	100V 15A	100V 30A	100V 45A	100V 60A
PSU 150-10	150V 10A	300V 10A	PSU 150-10	150V 10A	150V 20A	150V 30A	150V 40A
PSU 300-5	300V 5A	600V 5A	PSU 300-5	300V 5A	300V 10A	300V 15A	300V 20A
PSU 400-3.8	400V 3.8A	-	PSU 400-3.8	400V 3.8A	400V 7.6A	400V 11.4A	400V 15.2A
PSU 600-2.6	600V 2.6A	-	PSU 600-2.6	600V 2.6A	600V 5.2A	600V 7.8A	600V 10.4A

Remark : 1U → 43.6mm

To augment output power, the PSU-series can realize two-fold rated power (models under 300V) via 2 same model units in series connection; and four-fold rated power via 4 same model units in parallel connection so as to satisfy customers with large voltage and large current requirements. 2U height units in series connection can achieve maximum 600V output. 4U height units in parallel connection can output maximum 800A and 6240W.

B. REMOTE PROGRAM CONTROL (UP TO 31 UNITS CONNECTION)

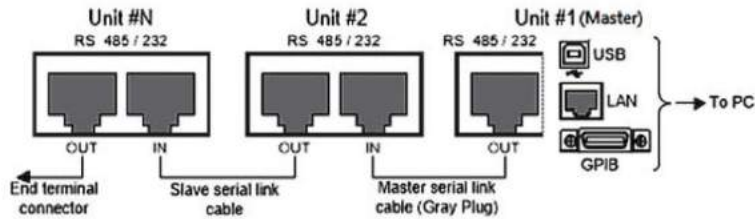

Provide RS-232, RS-485, USB, GPIB and LAN for PC to remote control Master PSU-Series. RJ-45 connector on the rear panel can connect up to 31 units.

LAN or USB remote control and augmenting slave units by using PSU-Series multi-drop mode will no longer need any switch/hub that can help customers save equipment costs.

* For the detailed information please refer to User Manual

C. C.V/C.C PRIORITY MODE

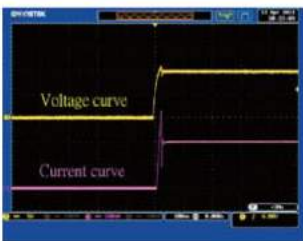

Under the conventional C.V mode, inrush current and surge voltage appeared at forward voltage (V_f) of LED.

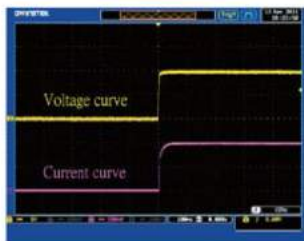

Under C.C priority mode, inrush and surge voltage are effectively restrained.

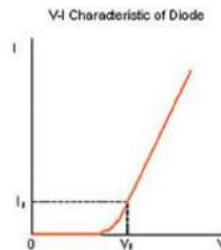

V-I Characteristic of Diode

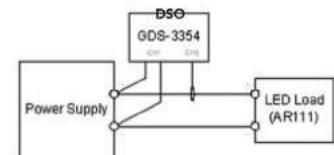

Using GDS-3354 DSO to Test LED Operation Under C.V Priority and C.C Priority Respectively

Conventional power supplies under the CV priority mode will produce inrush current and surge voltage at turn-on. The PSU-series has CV and CC priority modes.

The CC priority mode can prevent inrush current and surge voltage from occurring at turn-on to protect DUT.

Programmable Switching D.C. Power Supply

D. ADJUSTABLE SLEW RATE

VOLTAGE SLEW RATE	CURRENT SLEW RATE
0.001V~0.06V/msec (PSU 6-200)	0.001A~2A/msec (PSU 6-200)
0.001V~0.125V/msec (PSU 12.5-120)	0.001A~1.2A/msec (PSU 12.5-120)
0.001V~0.2V/msec (PSU 20-76)	0.001A~0.76A/msec (PSU 20-76)
0.001V~0.4V/msec (PSU 40-38)	0.001A~0.38A/msec (PSU 40-38)
0.001V~0.6V/msec (PSU 60-25)	0.001A~0.25A/msec (PSU 60-25)
0.001V~1.000V/msec (PSU 100-15)	0.001A~0.150A/msec (PSU 100-15)
0.001V~1.500V/msec (PSU 150-10)	0.001A~0.100A/msec (PSU 150-10)
0.001V~1.500V/msec (PSU 300-5)	0.001A~0.025A/msec (PSU 300-5)
0.001V~2.000V/msec (PSU 400-3.8)	0.001A~0.008A/msec (PSU 400-3.8)
0.001V~2.400V/msec (PSU 600-2.6)	0.001A~0.006A/msec (PSU 600-2.6)

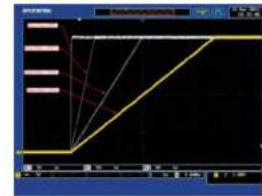

Adjustable Voltage Slew Rate

The PSU series can adjust slew rate for current and voltage. Via setting the rise and fall time of voltage and current, users can verify DUT's characteristics during voltage and current variation. Additionally, slew rate adjustment can mitigate voltage shift to effectively prevent DUT from being damaged by inrush current. This function is ideal for tests such as capacitive load and motor.

E. OVP, OCP AND UVL

PSU-Series	OCP	OVP	UVL
6-200	5 ~ 220	0.6 ~ 6.6	0 ~ 6.3
12.5-120	5 ~ 132	1.25 ~ 13.75	0 ~ 13.12
20-76	5 ~ 83.6	2 ~ 22	0 ~ 21
40-38	3.8 ~ 41.8	4 ~ 44	0 ~ 42
60-25	2.5 ~ 27.5	5 ~ 66	0 ~ 63
100-15	1.5 ~ 16.5	5 ~ 110	0 ~ 105
150-10	1 ~ 11	5 ~ 165	0 ~ 157.5
300-5	0.5 ~ 5.5	5 ~ 330	0 ~ 315
400-3.8	0.38 ~ 4.18	5 ~ 440	0 ~ 420
600-2.6	0.26 ~ 2.86	5 ~ 660	0 ~ 630

Once the voltage or current output exceeds the preset level of OVP or OCP, PSU will shut down output to protect DUT. UVL is for users to set the minimum output voltage from the output terminal.

F. TRIGGER CONTROL (TRIGGER INPUT/TRIGGER OUTPUT)

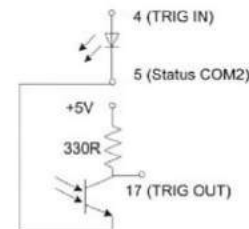

PSU-series provides users with complete trigger input and trigger output functions so as to flexibly control PSU-series. Each function is elaborated as follows.

Trigger Input function :

1. Allow users to set the effective pulse width from 0~60ms for trigger input (0: the LOW or HIGH signal of DC level for trigger input)
2. Receive trigger input to control PSU-series output or to output preset voltage and current.
3. Receive trigger input to upload preset memory parameters.

Trigger Output function :

1. Allow users to set the effective pulse width from 0~60ms for trigger output (0: the LOW or HIGH signal of DC level for trigger output)
2. Set LOW or HIGH for output DC level
3. PSU produces trigger output signal when setting output or changing preset value or uploading preset memory parameters.

G. EXTERNAL ANALOG CONTROL FUNCTION

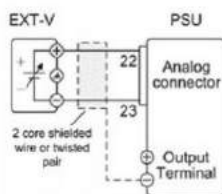

- Pin23 → EXT-V (-)
- Pin22 → EXT-V (+)
- Wire shield → negative (-) output terminal

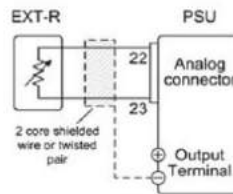

- Pin22 → EXT-R
- Pin23 → EXT-R
- Wire shield → negative (-) output terminal

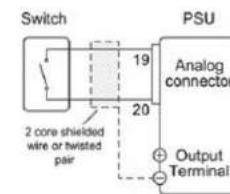

- Pin19 → Switch
- Pin20 → Switch
- Wire shield → negative (-) output terminal

External Voltage Controls Voltage Range

External Resistance Controls Voltage Range

External On-off to Control Output, on or off

The rear panel of the PSU-series has an analog control terminal. The external analog control interface allows external voltage or resistance to control voltage and current output; and allows power supply to output or to be turned on and off. The diagram on the upper shows typical connection methods for external control applications. For more detailed connection information please refers to user manual.



H. BLEEDER CONTROL

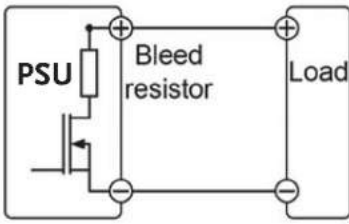

PSU-Series Built-in Bleed Resistor

The PSU-Series employs a bleed resistor in parallel with the output terminal. Bleed resistor is designed to dispatch the power from the power supply filter capacitors when power is turned off or the load is disconnected. Without a bleed resistor, power terminal may remain charged on the filter capacitors for some time and be potentially hazardous. In addition, bleed resistor also allows for smoother voltage regulation of the power supply as the bleed resistor acts as a minimum voltage load. The bleed resistance can be turned on or off using the configuration setting.

I. VARIOUS INTERFACES SUPPORT

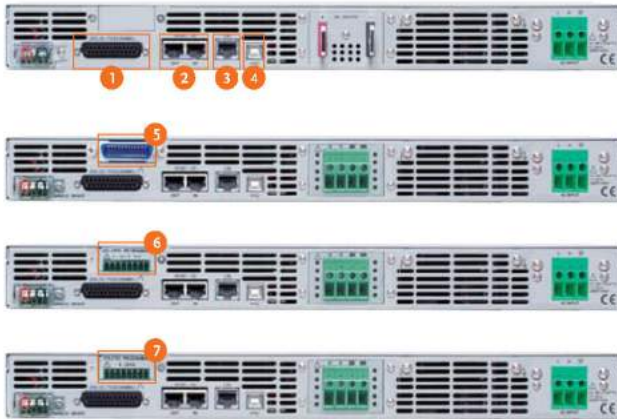

1. Analog Control Interface
2. RS485/RS232 Interface for Remote Control
3. LAN Port for System Communication
4. USB Interface for Remote Control
5. GPIB Interface for Remote Control
6. Isolate Voltage Remote Control Card
7. Isolate Current Remote Control Card

J. USING THE RACK MOUNT KIT



Rack Mount Kit for PSU-Series EIA & JIS

The rack mount kit of the PSU-Series supports both EIA and JIS standards. A standard rack can accommodate one unit of the PSU-Series.

K. OUTPUT ON / OFF DELAY

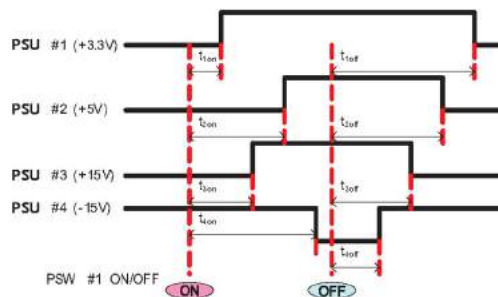

The Example of Output On/Off Delay Control Among Multiple Outputs of the PSU Units

The Output On/Off delay feature enables the setting of a specific time delay for output on after the power supply output is turned on, and a specific time delay for output off after the power supply output is turned off. When multiple PSU units are used, the On/Off

delay time of each unit can be set respectively referring to fix time points. This multiple-output control can be done through the analog control terminal at rear panel or through the PC programming with standard commands.

Programmable Switching D.C. Power Supply (Multi-range D.C. Power Supply)



PSB-2400L2



**PSB-2400L/PSB-2400H/
PSB-2800L/PSB-2800H**



PSB-2800LS



Note : PSB-2400H/PSB-2800H are not CE approved

FEATURES

- * Output Voltage Rating : 80V/800V, Output Power Rating : 400W ~ 800W
- * Constant Power Output for Multi-Range (V & I) Operation
- * Series and Parallel Operation (2 Units in Series or 4 Units in Parallel Maximum)
- * 90 Degree Angle Rotatable Control Panel
- * Sequence Function Edited by PC will be Controlled Through Power Supply Optional Interfaces
- * Standard Interface : RS-232C/USB/Analog Control Interface
- * Optional Interface : GPIB
- * Preset Function (3 Points)
- * LabVIEW Driver

The PSB-2000 Series is a high power density, programmable and multi-range output DC power supply. There are six models in the series including one power booster unit. The PSB-2000 Series has the output voltage of 0~80V and 0~800V, and the output power ranges of 0~400W and 0~800W. The multi-range output functionality facilitates flexible collocations of higher voltage and larger current under the rated power range. Both series and parallel connections can be applied to the PSB-2000 Series to fulfill the requirements of higher

The PSB-2000 Series provides three sets of preset function keys to memorize regularly used settings of voltage, current and power that users can recall rapidly. The sequence function, via RS232C, USB interface or optional GPIB interface, can connect with the computer to produce output power defined by sequence of a series of set voltage and current steps that are defined by the computer. This function is often used to establish a standard test procedure for the verification of the influence on DUTs done by the swiftly changing operating

The PSB-2000 Series protects over voltage and over current. The power supply output function will be shut down to protect DUTs while the protection mechanism is triggered to function. When conducting battery charging operation, the Hi-Ω mode of the PSB-2000 Series will prevent reverse current from damaging power supply.

The PSB-2000 Series provides analog control interfaces on the rear panel to control PSB-2000 Series output via the external voltage or to externally monitor voltage and current output status of power supply. The PSB-2000 Series panel can be rotated 90 degree angle suitable for vertical or horizontal position to accommodate the ideal space utilization.

SERIES OPERATION

MODEL NUMBER	SINGLE UNIT	TWO UNITS
PSB-2400L	80V/40A	160V/40A
PSB-2800L	80V/80A	160V/80A
PSB-2800LS (Booster Unit for PSB-2800L Only)	N/A	N/A
PSB-2400L2	N/A	N/A
PSB-2400H	N/A	N/A
PSB-2800H	N/A	N/A

PARALLEL OPERATION

MODEL NUMBER	SINGLE UNIT	TWO UNITS	THREE UNITS	FOUR UNITS
PSB-2400L	80V/40A	80V/80A	80V/120A	80V/160A
PSB-2800L	80V/80A	80V/160A	80V/240A	80V/320A
PSB-2800LS	N/A	80V/160A (PSB-2800L x 1+ PSB-2800LS x 1)	80V/240A (PSB-2800L x 1+ PSB-2800LS x 2)	N/A
PSB-2400L2	N/A	N/A	N/A	N/A
PSB-2400H	800V/3A	800V/6A	N/A	N/A
PSB-2800H	800V/6A	800V/12A	N/A	N/A

SPECIFICATIONS						
	PSB-2400L	PSB-2800L	PSB-2400L2	PSB-2400H	PSB-2800H	PSB-2800LS
OUTPUT RATING						
Voltage	0 – 80V	0 – 80V	0 – 80V x 2CH	0 – 800V	0 – 800V	80V
Current	0 ~ 40A	0 ~ 80A	0 ~ 40A x 2CH	0 ~ 3A	0 ~ 6A	80A
Power	400W	800W	800W	400W	800W	800W
REGULATION (CV)						
Load	0.01% ± 3mV of rated voltage			0.01% ± 30mV of rated voltage		N/A
Line	0.01% ± 2mV of rated voltage			0.01% ± 20mV of rated voltage		
REGULATION (CC)						
Load	0.02% ± 3mA of rated current			0.05% ± 15mA of rated current		N/A
Line	0.01% ± 2mA of rated current			0.05% ± 10mA of rated current		
RIPPLE & NOISE (Noise Bandwidth 20MHz ; Ripple Bandwidth=1MHz)						
CV p-p	90mV	150mV	90mV	250mV(only output voltage measures more than 1% of the rated voltage)	300mV(only output voltage measures more than 1% of the rated voltage)	N/A
CV rms	4mV	6mV	4mV	20mV(when current measures<2A) 35mV(when current measures>2A)	25mV(when current measures<2A) 40mV(when current measures>2A)	
CC rms	30mA	60mA	30mA	15mA	20mA	
PROGRAMMING ACCURACY						
Voltage	0.1% setting±2digits			0.1% setting±2digits		N/A
Current	0.2%setting±2digits			0.2% setting±2digits		
Power	± 10W			±10W (only output voltage measures more than 1% of rated voltage)		
READ BACK ACCURACY						
Voltage	0.2% reading±2digits			0.2% reading±2digits		N/A
Current	0.3% reading±2digits			0.3% reading±2digits		
Power	0.5% reading±5digits			0.5% reading±Vout x 40mA		
RESPONSE TIME						
Raise Time(Full load/No load)	50ms			200ms		N/A
Fall Time(Full load)	100ms			500ms		
Fall Time(No load)	500ms			1000ms		
Load Transient Recover Time (Load change from 50–100%)	1ms			7ms		
PROGRAMMING RESOLUTION						
Voltage	10mV			100mV		N/A
Current	10mA			10mA		
Power	10W			10W		
MEASUREMENT RESOLUTION						
Voltage	10mV			100mV		N/A
Current	10mA			10mA		
Power	10W			10W		
SERIES AND PARALLEL CAPABILITY						
Channel Number	1	1	2	1	1	
Series Operation	Up to 2 Units	Up to 2 Units	N/A	N/A	N/A	For PSB-2800L Only
Parallel Operation	Up to 4 Units	Up to 4 Units	N/A	Up to 2 Units	Up to 2 Units	
Parallel with booster PSB-2800LS	N/A	Up to 3 Units	N/A	N/A	N/A	
PROTECTION FUNCTION						
OVP (Fixed)	Output off when 110% of rated voltage			Output off when output voltage exceeds 110% of rated voltage		N/A
OVP (Variable)	Output off when operating; Setting range:1V–84V with front panel			Presettable in range from 10V ~ 840V om front panel		
OCP (Fixed)	Output off when 110% of rated current			Output off when output voltage exceed 110% of rated current		
OCP (Variable)	Output off when operating;Setting range:1A–42A(84A for model number)			Presettable in range from 0.1A ~ 6.30A om front panel		
OHP	Output off above heat sink setting temperature			Output off at the internal heat sink temperature over setting value		
ENVIRONMENT CONDITION						
Operation Temp	0°C ~ 40°C					N/A
Storage Temp	-20°C ~ 70°C					
Operating Humidity	30% ~ 80% RH (no dew condensation)					
Storage Humidity	30% ~ 80% RH (no dew condensation)					
OTHER						
Inrush Current	35A Max	70A Max	70A Mmax	35A Max	70A Max	70A Max
Power Consumption/Factor	560VA/0.99	1120VA/0.99	1120VA/0.99	560VA/0.99	1120VA/0.99	1120VA/0.99
Cooling Method	Forced air-cooling with fan motor					
Power Source	100VAC ~ 240VAC, 50/60Hz, Single phase					
Interface (Standard)	RS-232C/USB					
Interface (Optional)	GPIB					
Analog Control	Yes					
DIMENSIONS & WEIGHT						
	210(W) x 124(H) x 290(D)mm					
	Approx.5kg	Approx.7kg	Approx.7kg	Approx. 5kg	Approx. 6kg	Approx. 7kg

Programmable Switching D.C. Power Supply (Multi-range D.C. Power Supply)



PSB-2400L2



**PSB-2400L/PSB-2400H/
PSB-2800L/PSB-2800H**



PSB-2800LS

Rear Panel



PSB-003 Parallel Connection Kit for Horizontal Installation



PSB-004 Parallel Connection Kit for Vertical Installation



ORDERING INFORMATION

PSB-2400L	0~80V/0~40A/400W Multi-Range DC Power Supply
PSB-2800L	0~80V/0~80A/800W Multi-Range DC Power Supply
PSB-2400L2	0~80V x 2/0~40A x 2/800W Multi-Range DC Power Supply
PSB-2400H	0~800V/0~3A/400W Multi-Range DC Power Supply
PSB-2800H	0~800V/0~6A/800W Multi-Range DC Power Supply
PSB-2800LS	800W Slave (Booster) Unit For Current Extension Only

ACCESSORIES :

User Manual (CD) x 1, AC Power Cord x 1, External Control Connector (26pin), Screws for output terminals on rear panel, Protection covers for output terminals on rear panel, Protection caps for output terminals on the front panel, GND Cable, USB Cable (For Model Number : PSB-2400L; PSB-2800L; PSB-2400L2; PSB-2400H; PSB-2800H) Local Bus (For Model Number : PSB-2400L; PSB-2800L; PSB-2400L2; PSB-2400H; PSB-2800H)

OPTIONAL ACCESSORIES

PSB-001	GPIB Card	GTL-246	USB Cable
PSB-003	Parallel Connection Kit for Horizontal Installation. Kit Includes : (PSB-007 Joint Kit, Horizontal bus bar x 2 , PSB-005 x1)	GTL-248	GPIB Cable
PSB-004	Parallel Connection Kit for Vertical Installation. Kit Includes : (PSB-007 Joint Kit, Vertical bus bar x 2, PSB-005 x 1)	GRJ-1101	Modular Cable
PSB-005	Parallel Connection Signal Cable	GRA-424	Rack Mount Kit
PSB-006	Series Connection Signal Cable		
PSB-007	Joint Kit : Includes 4 Joining Plates, (M3x6)screws x 4 ; (M3x8) screw x 2		
PSB-008	RS232C Cable (PSB-2000 Only)		

FREE DOWNLOAD

Driver Labview Driver

PSB-001 GPIB Control Board



GRJ-1101 Modular Cable



PSB-008 RS-232C Cable (PSB-2000 Only)



PSB-005 Parallel Connection Signal Cable



PSB-006 Series Connection Signal Cable



PSB-007 Joint Kit



A. MULTI-RANGE OUTPUT OPERATION

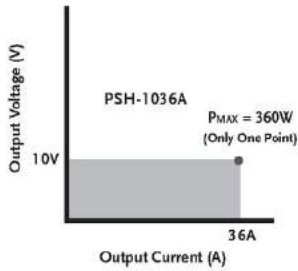

The operation area of a Conventional Power Supply

Compared with the maximum power output of the conventional power supply that is calculated by the maximum output voltage multiplies by the maximum output current, the PSB-2000 series, defying the formula, has a unique characteristic of multi-range output (voltage and current). This distinguishing feature, under the same maximum power output range, can output a higher voltage with a smaller current and vice versa. For instance, for a conventional power supply with a maximum power output of 360W, the maximum voltage and current outputs are likely to be

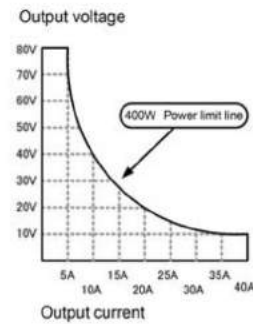

The operation area of a Multi-Range Power Supply for PSB-2000 Series

10V and 36A respectively. Comparatively, PSB-2400L, with the maximum power output of 400W, provides voltage and current output ranges of 0–80V and 0–40A. The maximum current of 5A will be provided when the voltage reaches 80V and the maximum voltage of 10V for the maximum current of 40A. PSB-2400L, breaking the limitation of $P_{max} = V_{max} \times I_{max}$, broadens voltage and current application ranges. The following diagrams illustrate the voltage and current comparison between the multi-range output power supply and the conventional power supply.

B. PRODUCTS IN THE SERIES

There are six models in the PSB-2000 Series. Model type, output voltage, output current and output power are as follows :

MODEL	PSB-2400L	PSB-2800L	PSB-2400L2	PSB-2400H	PSB-2800H	PSB-2800LS*
Channel Number	1	1	2	1	1	NA
Voltage Rating**	0 ~ 80V	0 ~ 80V	0 ~ 80V x 2CH	0 ~ 800V	0 ~ 800V	80V
Current Rating***	0 ~ 40A	0 ~ 80A	0 ~ 40A x 2CH	0 ~ 3A	0 ~ 6A	80A
Output Power (Max.)	400W	800W	800W	400W	800W	800W

* PSB-2800LS, a booster unit acting as slave to extend current, can not operate alone. It must operate with PSB-2800L master.

** The maximum current under the highest output voltage is power/voltage. For instance, when PSB-2400L outputs 80V the maximum current is $400W/80V = 5A$.

*** Same as above. When PSB2400L outputs 40A the highest voltage is $400W/40A = 10V$.

C. SERIES AND PARALLEL CONNECTIONS

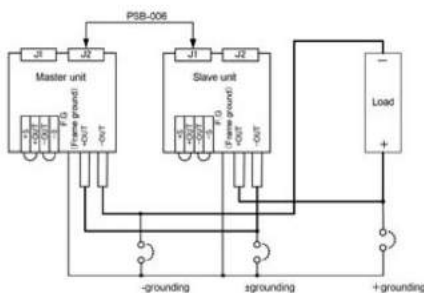

Series Connection

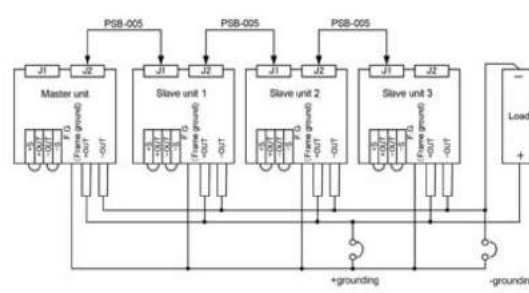

Parallel Connection

Hence, the PSB-2000 Series, with its multi-range output function and the power extension capability of series and parallel connections, is the high power density and high performance to cost ratio DC power supply, which provides

a wider range of power applications for any limited equipment space. The PSB-2000 Series is an ideal selection for testing DC power supply module, automobile lithium and lithium iron battery and electronic parts.

Programmable Multi-Range D.C. Power Supply



PSB-1000 Series



FEATURES

- * LCD Display and User-Friendly Menu-Typed Functional Interface
- * Voltage Rating : 40V/160V, Output Power Rating : 400W/800W
- * Constant Power Output for Multi-Range(V & I) Operation
- * The I/V Control Functions(Adjustable Slew Rate) are Suitable for Diode Characteristic Load & Surge Reducing
- * Sequence Function for Sequential D.C. Waveform Output
- * C.V/C.C Priority
- * Auto Run for Output or Sequence Function
- * Master-Slave Operation : 2 Units in Series/ 4 Units in Parallel
- * Synchronized Operation(Voltage Trigger, Trigger In/Trigger Out Signal)
- * Standard Interface : USB Host, LAN; Option : GPIB
- * Internal Sense Control(Disable/Front Panel/ Rear Panel)Function
- * LabVIEW Driver

PSB-106 Basic accessory kit :

M4 Terminal screws and washers x 2,
M8 Terminal bolts, Nuts and washers x 2,
Analog control protection dummy x 1,
Analog control lock level x 2, Short bar x 1



PSB-1000 is a series of Multi-Range DC Power Supply, whose maximum voltage output of 320V can be realized by placing 2 sets of 160V units in series connection. By connecting 4 sets of PSB-1800L units in parallel, the maximum current output of 320A can be achieved.

The PSB-1000 series is a bench-top power supply featuring user friendly interface, which can clearly display setting conditions and measurement results via LCD display and menu-typed functionality selection without referring to the user manual. All settings can be done by functionality keys, numerical keys, and speed dial keys. The 30A output capability from the front output terminal of the PSB-1000 series can better meet the requirements of laboratories and scientific R&D departments.

The PSB-1000 series features user friendly menu-typed functionality interface and its built-in functionalities can better meet industry's application requirements. Both front panel and rear panel output terminals of the PSB-1000 series facilitate researchers to access power output conveniently. The display panel adopts menu-typed functionality selection to help users quickly familiarize with settings and operation that is extremely suitable for on-site engineers and R&D engineers who deal with complicated functional setting requirements. Power On Configuration allows users to select previously set SEQ to carry out automatic execution as soon as power is turned on. For production lines demanding sequential power supply output application requirements, tremendous time can be saved by this function, which exempts users from resetting sequential power supply when power is turned on every single time.

Voltage Trigger allows users to set pulse signals for leading edge threshold and trailing edge threshold. VOLT TRIG can be applied to Automatic test system by providing output time for working voltage via BNC adapter. The Output Delay function facilitates users to respectively set action time for power output on and power output off for multiple sets of PSB-1000 so as to realize sequential power output applications.

The PSB-1000 series is equipped with multi range power output capability providing fourfold rated power output to meet customers' flexible application requirements.

SPECIFICATIONS

Model Name	PSB-1400L	PSB-1400M	PSB-1800L	PSB-1800M
OUTPUT RATING				
Output Voltage(V)	0~40	0~160	0~40	0~160
Output Current(A)	0~40	0~10	0~80	0~20
Output Power(W)	400W	400W	800W	800W
REGULATION (CV)				
Load Regulation (mV)	25	85	25	85
Line Regulation (mV)	23	83	23	83
REGULATION (CC)				
Load Regulation (mA)	45	15	85	25
Line Regulation (mA)	45	15	85	25
RIPPLE & NOISE (Noise Bandwidth 20MHz ; Ripple Bandwidth = 1MHz)				
CV p-p	60	60	80	80
CV rms	7	12	11	15
CC rms	80	20	160	40
PROGRAMMING ACCURACY				
Voltage (mV) 0.1% +	10	50	10	50
Current (mA) 0.1% +	20	10	40	20
MEASUREMENT ACCURACY				
Voltage (mV) 0.1% +	10	50	10	50
Current (mA) 0.1% +	20	10	40	20
RESPONSE TIME				
Raise Time (ms)	50	100	50	100
Fall Time(Full load) (ms)	50	150	50	150
Fall Time(No load) (ms)	500	1200	500	1200
Load Transient Recover Time(ms) (Load change from 50 to 100%)	1	1	1	1
PROGRAMMING RESOLUTION (By PC Remote Control Mode)				
Voltage (mV)	1	3	1	3
Current (mA)	1	1	2	1
MEASUREMENT RESOLUTION (By PC Remote Control Mode)				
Voltage (mV)	1	3	1	3
Current (mA)	1	1	2	1
SERIES AND PARALLEL CAPABILITY				
Parallel Operation	Up to 4 units including the master unit			
Series Operation	Up to 2 units including the master unit			
PROTECTION FUNCTION				
OVP (V)	4-44	5-176	4-44	5-176
OCP (A)	4-44	1-11	5-88	2-22
OHP	Turn the output off.	Turn the output off.	Turn the output off.	Turn the output off.



PSB-1000 Series

SPECIFICATIONS

Model Name	PSB-1400L	PSB-1400M	PSB-1800L	PSB-1800M	
FRONT PANEL DISPLAY ACCURACY (4 Digits)					
Voltage (mV)	0.1% +	20	100	20	100
Current (mA)	0.1% +	20	10	40	20
ENVIRONMENT CONDITION					
Operation Temp	0°C ~ 40°C				
Storage Temp	-25°C ~ 70°C				
Operating Humidity	20% ~ 85% RH; No condensation				
Storage Humidity	90% RH or less; No condensation				
OTHER					
Analog Control Interface	Yes				
Power Source	100Vac ~ 240Vac, 50Hz ~ 60Hz, single phase				
Dimension	214(W)×124(H)×350(D) mm				
Weight	Approx. 5.2kg	Approx. 5.2kg	Approx. 6.8kg	Approx. 6.8kg	

ORDERING INFORMATION

PSB-1400L	40V/40A/400W Programmable Multi-Range D.C. Power Supply
PSB-1400M	160V/10A/400W Programmable Multi-Range D.C. Power Supply
PSB-1800L	40V/80A/800W Programmable Multi-Range D.C. Power Supply
PSB-1800M	160V/20A/800W Programmable Multi-Range D.C. Power Supply

ACCESSORIES :

CD ROM (User Manual, Programming Manual) x 1, Power cord for UL/CSA or PSE(Region dependent), Output terminal cover, Type A-B USB cable, PSB-106 Basic accessory kit : M4 terminal screws and washers x 2, M8 Terminal bolts, Nuts and washers x 2, Analog control protection dummy x 1, Analog control lock level x 2, Short bar x 1

OPTIONAL ACCESSORIES

PSW-001	Analog remote control connector kit
PSW-002	Simple IDC tool
PSW-003	Contact removal tool
PSB-101	Cable for 2 units of PSB-1000 in parallel connection
PSB-102	Cable for 3 units of PSB-1000 in parallel connection
PSB-103	Cable for 4 units of PSB-1000 in parallel connection
PSB-104	Cable for 2 units of PSB-1000 in series connection
PSB-105	GPIB card
PSB-106	Basic accessory kit : M4 Terminal screws and washers x 2, M8 Terminal bolts, Nuts and washers x 2, Analog control protection dummy x 1, Analog control lock level x 2, Short bar x 1
GRA-418-J	Rack Mount Kit(JIS)
GRA-418-E	Rack Mount Kit(EIA)
GTL-123	Test leads:1x red,1x black

FREE DOWNLOAD

Driver	Labview Driver
--------	----------------

Rear Panel



PSB-101 Cable for 2 units of PSB-1000 in parallel connection



PSB-102 Cable for 3 units of PSB-1000 in parallel connection



PSB-103 Cable for 4 units of PSB-1000 in parallel connection



PSB-104 Cable for 2 units of PSB-1000 in series connection



Programmable Switching D.C. Power Supply



PSH-Series



FEATURES

- * Wide Input Voltage Range and High Power Factor (P.F)
- * High Efficiency and High Power Density
- * Constant Voltage and Constant Current Operation
- * Over Voltage , Over Current and Over Temperature Protection
- * Self-Test and Software Calibration
- * Output ON/OFF Control
- * Low Ripple and Noise
- * LCD Display
- * Built-in Buzzer Alarm
- * Standard Interface : RS-232C
- * Optional Interface : GPIB (IEEE-488.2)
- * LabVIEW Driver

Rear Panel



The PSH-Series is single output from 360W to 1080W, programmable switching DC power supplies. OVP, OCP and OTP protect the power supply and loads from unexpected conditions. Remote sensing adds an extra level of precision by compensating cable losses between loads. The bright LCD with simultaneous parameter outputs allows effortless operation. Self-test and software calibration features also reduce maintenance overhead. SCPI commands and LabVIEW driver access through the RS-232C or the optional GPIB interface allow remote control and ATE software development capability. Modular architecture, dedicated rear-panel output, and the 19 inch 4U rack mounting option ensure that the PSH-Series is optimized for large systems.

SPECIFICATIONS				
	PSH-2018A	PSH-3610A	PSH-3620A	PSH-3630A
OUTPUT				
Voltage	20V	36V	36V	36V
Current	18A	10A	20A	30A
REGULATION (C.V.)				
Load	≤ 0.1%+5mV	≤ 0.1%+5mV	≤ 0.1%+5mV	≤ 0.1%+5mV
Line	≤ 0.05%+5mV	≤ 0.05%+5mV	≤ 0.05%+5mV	≤ 0.05%+5mV
REGULATION (C.C.)				
Load	≤ 0.2%+5mA	≤ 0.2%+5mA	≤ 0.2%+10mA	≤ 0.2%+15mA
Line	≤ 0.2%+5mA	≤ 0.2%+5mA	≤ 0.2%+10mA	≤ 0.2%+15mA
RIPPLE & NOISE				
Voltage (mVrms)	≤ 10mVrms	≤ 10mVrms	≤ 10mVrms	≤ 10mVrms
Voltage (mVp-p)	≤ 100mVp-p	≤ 100mVp-p	≤ 100mVp-p	≤ 100mVp-p
	20Hz~20MHz	20Hz~20MHz	20Hz~20MHz	20Hz~20MHz
Current (mA rms)	≤ 0.2%	≤ 0.2%	≤ 0.2%+20mA	≤ 0.2%+40mA
RESOLUTION				
Voltage	10mV	10mV	10mV	10mV
Current	10mA	10mA	10mA	10mA
PROGRAM ACCURACY				
Voltage	≤ 0.05%+25mV	≤ 0.05%+25mV	≤ 0.05%+25mV	≤ 0.05%+25mV
Current	≤ 0.2%+30mA	≤ 0.2%+30mA	≤ 0.2%+30mA	≤ 0.2%+30mA
READBCK RESOLUTION (Meter)				
Voltage	Same as Resolution	Same as Resolution	Same as Resolution	As Resolution
Current	Same as Resolution	Same as Resolution	Same as Resolution	As Resolution
READBCK ACCURACY (Meter)				
Voltage	Same as Program Accuracy	Same as Program Accuracy	Same as Program Accuracy	As Program Accuracy
Current	Same as Program Accuracy	Same as Program Accuracy	Same as Program Accuracy	As Program Accuracy
READBCK TEMP. COEFFICIENT				
Voltage (25 ±5°C)	≤ 100ppm/°C	≤ 100ppm/°C	≤ 100ppm/°C	≤ 100ppm/°C
RESPONSE (Rise/Fall) TIME				
Voltage Up (10%~90%)	≤ 150mS	≤ 150mS	≤ 150mS	≤ 150mS
	(≤95% rating load)	(≤95% rating load)	(≤95% rating load)	(≤95% rating load)
Voltage Down (90%~10%)	≤ 150mS	≤ 150mS	≤ 150mS	≤ 150mS
	(≥10% rating load)	(≥10% rating load)	(≥10% rating load)	(≥10% rating load)
RECOVERY TIME (50% Step Load Change From 25%~75%)				
CV Mode	≤ 2mS	≤ 2mS	≤ 2mS	≤ 2mS
PROTECTION				
OVP/OCP/OTP	✓	✓	✓	✓
Rush Current	✓	✓	✓	✓
OUTPUT ON/OFF CONTROL				
	✓	✓	✓	✓
INTERFACE				
	Standard : RS-232C; Optional : GPIB			
POWER SOURCE				
	AC90V~250V, 50/60Hz			
DIMENSIONS & WEIGHT				
	108(W)x142(H)x393(D) mm; Approx. 3.3kg	108(W)x142(H)x393(D) mm; Approx. 3.3kg	188(W)x142(H)x393(D) mm; Approx. 6.2kg	268(W)x142(H)x393(D) mm; Approx. 9.3kg

ORDERING INFORMATION

- PSH-2018A 360W Programmable Switching D.C. Power Supply
- PSH-3610A 360W Programmable Switching D.C. Power Supply
- PSH-3620A 720W Programmable Switching D.C. Power Supply
- PSH-3630A 1080W Programmable Switching D.C. Power Supply

ACCESSORIES :
User manual x 1 , Power cord x 1

OPTION

Opt. 01: GPIB Interface (Factory Installed)

OPTIONAL ACCESSORIES

- GRA-403 Rack Mount Kit
- CTL-232 RS-232C Cable, 9-pin Female to 9-pin, null Modem for Computer
- CTL-122 Test Lead, U-type to Alligator Test Lead, Max. Current 40A, 1200mm
- CTL-248 GPIB Cable, Double Shielded, 2000mm

FREE DOWNLOAD

- PC Software PC Software including Data Log ; Remote Control Software
- Driver Labview Driver

Note : When Opt.01 GPIB interface is ordered, the standard interface RS-232C will be deleted.

Programmable Switching D.C. Power Supply



PSP-603/405/2010



FEATURES

- * LCD Display
- * Output ON/OFF Control
- * 3 Step Fan Speed Control
- * Voltage/Current/Power Setting
- * Key Lock to Avoid Error Operation
- * Normal, +% & -% Output Operation Key
- * Standard Interface : RS-232C
- * Optional European Type Jack Terminal

European Type Jack Terminal



Rear Panel



The PSP-Series is single output, 200W, programmable switching DC power supplies. OVL, OCL, OTP, and OPL protect the PSP-Series and its loads from unexpected conditions. The PSP-Series has a large LCD panel with output and parameter views and a key lock feature to prevent changing the settings. The PSP-Series is suitable for generic bench-top applications in laboratories and educational institutions.

SPECIFICATIONS			
OUTPUT			
Model	PSP-603	PSP-405	PSP-2010
Voltage	0 ~ 60V	0 ~ 40V	0 ~ 20V
Current	0 ~ 3.5A	0 ~ 5A	0 ~ 10A
VOLTAGE REGULATION			
Load	≤ 10mV	≤ 10mV	≤ 10mV
Line	≤ 0.05%	≤ 0.05%	≤ 0.05%
CURRENT REGULATION			
Load	≤ 5mA	≤ 5mA	≤ 5mA
Line	≤ 0.05%	≤ 0.05%	≤ 0.05%
RIPPLE			
Voltage (mVrms)	≤ 20mV	≤ 20mV	≤ 20mV
Current (mA rms)	≤ 10mA	≤ 10mA	≤ 10mA
RESOLUTION			
Voltage	20mV	10mV	10mV
Current	2mA	2mA	5mA
PROGRAM ACCURACY			
Voltage	± 0.05%rdg ± 4digits	± 0.05%rdg ± 3digits	± 0.05%rdg ± 3digits
Current	± 0.1%rdg + 5digits	± 0.1%rdg + 5digits	± 0.3%rdg + 10digits
READBACK (METER) RESOLUTION			
Voltage	Same as Resolution	Same as Resolution	Same as Resolution
Current	Same as Resolution	Same as Resolution	Same as Resolution
READBACK (METER) ACCURACY			
Voltage	Same as Program Accuracy	Same as Program Accuracy	Same as Program Accuracy
Current	Same as Program Accuracy	Same as Program Accuracy	Same as Program Accuracy
PROTECTION			
OVL/OCL/OPL/OTP	✓	✓	✓
OUTPUT ON/OFF CONTROL			
	✓	✓	✓
DISPLAY			
LCD			
INTERFACE (STANDARD)			
RS-232C			
POWER SOURCE			
AC 115V ± 10%, AC 230V ± 15%, 50/60Hz			
DIMENSIONS & WEIGHT			
225(W) x 100(H) x 305(D) mm ; Approx. 4kg			

ORDERING INFORMATION

- PSP-603 200W Programmable Switching DC Power Supply
- PSP-405 200W Programmable Switching DC Power Supply
- PSP-2010 200W Programmable Switching DC Power Supply

ACCESSORIES :

User manual x 1, Power cord x 1, Test lead GTL-104A x 1, European test lead GTL-204A x 1

OPTIONAL ACCESSORIES

GTL-232A RS-232C Cable

FREE DOWNLOAD

PC Software RS-232C Remote Control Software

Programmable High Precision D.C. Power Supply



PPH-1503

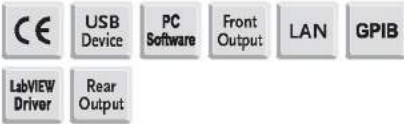

PPH-1503D/1506D/1510D



PPH-Series high precision measurement capability achieves the maximum resolution of 1mV/0.1μA and the smallest pulse current width of 33μs that satisfy customers' measurement application requirements of high resolution and pulse current. Fast load current variation will result in voltage sag for general power supplies that will have an impact on DUT's internal circuit operation. PPH-Series is equipped with the excellent transient recovery time, which can, in less than 40μs, recover the output voltage to within 100mV of the previous voltage output when the current level changes from 10% to 100% of the full scale. Furthermore, conventional power supplies do not have sufficient response speed to promptly respond to set voltage value once the set voltage is changed. PPH-15xxD has a rise time of 0.2ms and a fall time of 0.3ms, which are 100 times faster than that of conventional power supplies. Therefore, PPH-15xxD can provide DUT with a stable output voltage even when DUT is operating under large transient current output. The internal high-speed sampling circuit design of PPH-15xxD, with the sample rate of 64K, can conduct pulse current measurement without using a current probe and oscilloscope. The current read back accuracy is 0.2%+1μA (equals to 11μA) at 5mA range, and the read back resolution is 0.1μA that allow DUT to be measured with a high accuracy level. Unlike battery, general power supplies, which do not have the characteristics of fast transient recovery time, can not maintain a stable power supply for cellular phone, wireless device, and wearable device which produce large transient pulse current load for hundreds of μs to dozens of ms when in use. PPH-15xxD, different from general power supplies, has the characteristics of fast transient recovery time. While simulating battery to output pulse current, PPH-15xxD can quickly compensate the voltage drop caused by pulse current. PPH-15xxD's CH1 has the built-in battery simulation function, which can define output impedance settings so as to accurately simulate battery's impedance characteristics during battery discharge. Fast transient recovery time and built-in battery simulation function together facilitate PPH-15xxD to accurately simulate battery's real behavior pattern so as to conduct product tests.

PPH-15xxD is not only suitable for simulating battery, charger and supplying power to DUT, but also ideal for simulating an electronic load to conduct discharge tests with its sink current capability. The sink current function allows PPH-15xxD to simulate a voltage source with the sink current capability. The maximum sink current of PPH-15xxD's CH1 is 3.5A and for CH2 is 3A. Long integration current measurement can be utilized to conduct average current measurement for periodical pulse current in a long period of time that is applied to analyze power consumption for a period of time. One of the applications is to measure the average power consumption of a cellular phone in use so as to conduct the internal RF module parameter analysis. The maximum pulse current measurement range of CH1 is 5A and for CH2 is 3A. The built-in sequence function of CH1 provides users with 1000 steps to edit sequential outputs, including voltage, current and execution time. The built-in DVM function of CH2 has a voltage range from 0 to +20VDC that saves users the cost of purchasing an additional voltage meter.

PPH-15xxD provides OTP function and shows heat sink temperature on the upper right corner of the display screen. Other than that, features such as five sets of system setting values for the SAVE/RECALL function, 10 sets of Power On Setup Settings, Key-Lock function to prevent unauthorized inputs, temperature-controlled fan to reduce noise, hardcopy to save screen information, and external relay control device together augment PPH-15xxD's usability. PPH-Series supports test requirements of Profile1, Profile2 and Profile3 from USB Power Delivery(PD) constructed by USB-IF association.

FEATURES

- * 3.5" TFT LCD Display
- * High Measurement Resolution: 1mV/0.1μA for 5mA range.
- * Transient Recovery Time: ≤40μs within 100mV; <80μs within 20mV
- * Current Sink Function
- * Pulse Current Measurement (Pulse width min.: 33μs)
- * Long Integration Current Measurement
- * Built-in DVM Measurement Function
- * Sequence Function (Sequence power output)
- * Built-in Battery Simulation Function (CH1 of PPH-15xxD)
- * OVP, OCP, OTP & Temperature Display for Heat Sink
- * Support USB (Device & Host)/GPIB/LAN
- * Five Groups of Save/Recall Setting
- * External Relay Control

PPH-1503 Rear Panel



PPH-1503D/1506D/1510D Rear Panel



SELECTION GUIDE

Model	PPH-1503	PPH-1503D	PPH-1506D	PPH-1510D
Channel	1	2	2	2
Dual Range Output	Channel 1: 0~15V/0~3A or 0~9V/0~5A Channel 2: NA	0~15V/0~3A or 0~9V/0~5A 0~12V/0~1.5A	0~15V/0~3A or 0~9V/0~5A 0~12V/0~3.0A	0~15V/0~3A or 0~9V/0~5A Rear Terminal: 0~10A(0~4.5V) 0~12V/0~3.0A
Display	3.5 Inch TFT LCD	3.5 Inch TFT LCD	3.5 Inch TFT LCD	3.5 Inch TFT LCD
Current Measurement Range	5A/5mA	5A/500mA/5mA(CH1)	5A/500mA/5mA(CH1)	10A/500mA/5mA(CH1)
CV&CC	✓	✓	✓	✓
Built-in DVM Measurement Function	✓	✓ (CH2)	✓ (CH2)	✓ (CH2)
Pulse Current Measurement	✓	✓	✓	✓
Long integration Current Measurement	✓	✓	✓	✓
Battery Simulation	NA	✓ (CH1)	✓ (CH1)	✓ (CH1)
Automated Sequential Output	✓	✓ (CH1)	✓ (CH1)	✓ (CH1)
High Measurement Resolution	✓ (1mV/0.1 μA)	✓ (1mV/0.1 μA)	✓ (1mV/0.1 μA)	✓ (1mV/0.1 μA)
Sink Current Capability	✓ (Max : 2A)	✓ (Max : 3.5A)	✓ (Max : 3.5A)	✓ (Max : 3.5A)
Selectable Output From Front or Rear Panel	✓	✓	✓	✓
Relay Output Control	✓	✓	✓	✓
Memory	5 Sets	5 Sets	5 Sets	5 Sets
Sample Rate	60K	64K	64K	64K
Lock Function	✓	✓	✓	✓
Protection Function	OVP/OTP/OCP	OVP/OTP/OCP	OVP/OTP/OCP	OVP/OTP/OCP
Four Wire Output Open Circuit Protection	NA	✓	✓	✓
Temperature Display for Heat Sink	NA	✓	✓	✓
Standard Interface:	GPIB	✓	✓	✓
LAN, USB, Analog Control	LAN	✓ (CDC)	✓ (TMC)	✓ (TMC)
Interface	LAN	✓	✓	✓

ORDERING INFORMATION

PPH-1503	(0~15V/0~3A or 0~9V/0~5A) High Precision DC Power Supply
PPH-1503D	(CH1:0~15V/0~3A or 0~9V/0~5A;CH2:0~12V/0~1.5A) High Precision Dual Channel Output DC Power Supply
PPH-1506D	(CH1:0~15V/0~3A or 0~9V/0~5A;CH2:0~12V/0~3A) High Precision Dual Channel Output DC Power Supply
PPH-1510D	(CH1:0~15V/0~3A or 0~9V/0~5A, 0~4.5V/0~10A(Rear terminal);CH2:0~12V/0~3A) High Precision Dual Channel Output DC Power Supply

ACCESSORIES :

CD (User manual x1, Quick start manual x1), Power cord (Region dependent), Test lead GTL-207A x 1, GTL-203A x 1, GTL-204A x 1

OPTIONAL ACCESSORIES

GTL-246 USB Cable (USB 2.0, A-B Type)

SPECIFICATIONS								
Model	PPH-1503	PPH-1503D		PPH-1506D		PPH-1510D		
OUTPUT RATING								
Number of Output Channel	1		2		2		2	
Channel No.	Ch 1	Ch 1	Ch 2	Ch 1	Ch 2	Ch 1	Ch 2	
Power	45W	45W	18W	45W	36W	45W	36W	
Voltage	0 ~ 15V or 0 ~ 9V	0 ~ 15V or 0 ~ 9V	0 ~ 12V	0 ~ 15V or 0 ~ 9V	0 ~ 12V	0 ~ 15V or 0 ~ 9V	0 ~ 12V	
Current	0 ~ 3A or 0 ~ 5A	0 ~ 3A or 0 ~ 5A	0 ~ 1.5A	0 ~ 3A or 0 ~ 5A	0 ~ 3.0A	0 ~ 3A or 0 ~ 5A Rear: 0~10A (under 0~4.5V)	0 ~ 3.0A	
Output Voltage Rising Time	0.15ms (10% ~ 90%)	0.20ms (10% ~ 90%)		0.20ms (10% ~ 90%)		0.20ms (10% ~ 90%)		
Output Voltage Falling Time	0.65ms (90% ~ 10%)	0.30ms (90% ~ 10%)		0.30ms (90% ~ 10%)		0.30ms (90% ~ 10%)		
STABILITY								
Voltage	0.01%+0.5mV	0.01%+3.0mV		0.01%+3.0mV		0.01%+3.0mV		
Current	0.01%+50 μ A	—		—		—		
REGULATION (CV)								
Load	0.01%+2mV	0.01%+2mV		0.01%+2mV		0.01%+2mV		
Line	0.5mV	0.5mV		0.5mV		0.5mV		
REGULATION (CC)								
Load	0.01%+1mA	0.01%+1mA		0.01%+1mA		0.01%+1mA		
Line	0.5mA	0.5mA		0.5mA		0.5mA		
 RIPPLE & NOISE (20Hz~20MHz)								
CV p-p	8mV	\leq 5A : 8mVp-p(20Hz~20MHz)		\leq 5A : 8mVp-p(20Hz~20MHz)		\leq 5A : 8mVp-p(20Hz~20MHz)		
CV rms	1mV	3mV(0~1MHz)		3mV(0~1MHz)		3mV(0~1MHz)		
CC rms	—	—		—		—		
PROGRAMMING ACCURACY								
Voltage	0.05%+10mV	0.05%+10mV		0.05%+10mV		0.05%+10mV		
Current(Ch1:5A,10A/CH2:1.5A,3A)	0.16%+5mA	0.16%+5mA(5A/1.5A)		0.16%+5mA(5A/3A)		0.16%+5mA(5A/3A)		
Current (500mA)	—	0.16%+0.5mA		0.16%+0.5mA		0.16%+0.5mA		
Current (5mA)	—	0.16%+5 μ A		0.16%+5 μ A		0.16%+5 μ A		
 READBACK ACCURACY								
Voltage	0.05%+3mV	0.05%+3mV		0.05%+3mV		0.05%+3mV		
Current(Ch1:5A,10A/CH2:1.5A,3A)	0.2%+400 μ A(5A)	0.2%+400 μ A(5A)		0.2%+400 μ A(5A)		0.2%+400 μ A(5A)		
Current (500mA)	—	0.2%+100 μ A		0.2%+100 μ A		0.2%+100 μ A		
Current (5mA)	0.2%+1 μ A	0.2%+1 μ A		0.2%+1 μ A		0.2%+1 μ A		
RESPONSE TIME								
Transient Recovery Time (Response to 1000% Load Change)	<40 μ S (within 100mV) <80 μ S (within 20mV)	<40 μ S (within 100mV, Rear) <50 μ S (within 100mV, Front) <80 μ S (within 20mV)		<40 μ S (within 100mV, Rear) <50 μ S (within 100mV, Front) <80 μ S (within 20mV)		<40 μ S (within 100mV, Rear) <50 μ S (within 100mV, Front) <80 μ S (within 20mV)		
PROGRAMMING RESOLUTION								
Voltage	2.5mV	2.5mV	2.5mV	2.5mV	2.5mV	2.5mV	2.5mV	
Current (5A range)	1.25mA	1.25mA(5A)	1.25mA	1.25mA(5A)	1.25mA	1.25mA(5A)	1.25mA	
Current (500mA range)	—	0.125mA	—	0.125mA	—	0.125mA	—	
Current (5mA range)	—	1.25 μ A	—	1.25 μ A	—	1.25 μ A	—	
 READBACK RESOLUTION								
Voltage	1mV	1mV	1mV	1mV	1mV	1mV	1mV	
Current (5A range)	0.1mA	0.1mA(5A)	0.1mA(1.5A)	0.1mA(5A)	0.1mA(3A)	0.1mA(5A)	0.1mA(3A)	
Current (500mA range)	—	0.01mA	—	0.01mA	—	0.01mA	—	
Current (5mA range)	0.1 μ A	0.1 μ A	0.1 μ A	0.1 μ A	0.1 μ A	0.1 μ A	0.1 μ A	
PROTECTION FUNCTION								
OVP Accuracy	50mV	Ch1: 0.8V		Ch1: 0.8V		Ch1: 0.8V		
OVP Resolution	10mV	10mV		10mV		10mV		
DVM								
DC Readback Accuracy(23°C±5°C)	±0.05%+3mV	—		±0.05%+3mV		±0.05%+3mV		
Readback Resolution	1mV	—		1mV		1mV		
Input Voltage Range	0 ~ 20VDC	—		0 ~ 20VDC		0 ~ 20VDC		
Maximum Input Voltage	—	—		-3V, +22V		-3V, +22V		
Input Resistance and Capacitance	100000M Ω	—		20M Ω		20M Ω		
PROGRAMMABLE OUTPUT RESISTANCE								
Range	—	0.001 Ω ~ 1.000 Ω		0.001 Ω ~ 1.000 Ω		0.001 Ω ~ 1.000 Ω		
Programming Accuracy	—	0.5% + 10 m Ω		0.5% + 10 m Ω		0.5% + 10 m Ω		
Resolution	—	1m Ω		1m Ω		1m Ω		
PULSE CURRENT MEASUREMENT								
Trigger Level	5mA ~ 5A, 5mA/Step	5mA ~ 5A, 5mA/Step		5mA ~ 5A, 5mA/Step		5mA ~ 5A, 5mA/Step		
High Time/low Time/ Average Time	33.3 μ s ~ 833ms, 33.3 μ s/Step	33.3 μ s ~ 833ms, 33.3 μ s/Step		33.3 μ s ~ 833ms, 33.3 μ s/Step		33.3 μ s ~ 833ms, 33.3 μ s/Step		
Trigger Delay	0 ~ 100ms, 10 μ s/Steps	0 ~ 100ms, 10 μ s/Steps		0 ~ 100ms, 10 μ s/Steps		0 ~ 100ms, 10 μ s/Steps		
Average Readings	1 ~ 100	1 ~ 100		1 ~ 100		1 ~ 100		
Long Integration Pulse Time	15 ~ 63S	15 ~ 63S		15 ~ 63S		15 ~ 63S		
Long Integration Measurement Time	850ms(60Hz)/840ms(50Hz)~60s, or Auto time 16.7ms/Steps(60Hz), 20ms/Steps(50Hz)	850ms(60Hz)/840ms(50Hz)~60s, or Auto time 16.7ms/Steps(60Hz), 20ms/Steps(50Hz)		850ms(60Hz)/840ms(50Hz)~60s, or Auto time 16.7ms/Steps(60Hz), 20ms/Steps(50Hz)		850ms(60Hz)/840ms(50Hz)~60s, or Auto time 16.7ms/Steps(60Hz), 20ms/Steps(50Hz)		
Long Integration Trigger Mode	Rising, Falling, Neither	Rising, Falling, Neither		Rising, Falling, Neither		Rising, Falling, Neither		
OTHERS								
Output Terminal	Front/Rear Panel	Front/Rear Panel		Front/Rear Panel		Front/Rear Panel		
DVM Input	Front/Rear Panel	— Front Panel		— Front Panel		— Front Panel		
Relay Control Connector	150mA/15V, 5V output, 100mA	150mA/15V, 5V output, 100mA		150mA/15V, 5V output, 100mA		150mA/15V, 5V output, 100mA		
Operation Temperature	0 ~ 40°C	0 ~ 40°C		0 ~ 40°C		0 ~ 40°C		
Operation Humidity	\leq 80%	\leq 80%		\leq 80%		\leq 80%		
Storage Temperature	-20°C ~ 70°C	-20°C ~ 70°C		-20°C ~ 70°C		-20°C ~ 70°C		
Storage Humidity	< 80%	< 80%		< 80%		< 80%		
PC REMOTE INTERFACES								
Standard	GPIB/USB/LAN		GPIB/USB/LAN		GPIB/USB/LAN		GPIB/USB/LAN	
CURRENT SINK CAPACITY								
Sink Current Rating	2A (Vout \leq 5V); 2A-0.1*(Vout-5) (Vout > 5V)	Ch1: 0~4V: 3.5A; 4~15V: 3.5A (0.25A/V) *(Vset-4V)		Ch1: 0~4V: 3.5A; 4~15V: 3.5A (0.25A/V) *(Vset-4V)		Ch1: 0~4V: 3.5A; 4~15V: 3.5A (0.25A/V) *(Vset-4V)		
MEMORY								
Save/Recall	5 Sets		5 Sets		5 Sets		5 Sets	
POWER								
Input Power	90 ~ 264VAC ; 50/60Hz		90 ~ 264VAC ; 50/60Hz		90 ~ 264VAC ; 50/60Hz		90 ~ 264VAC ; 50/60Hz	
Power Consumption	150W		160W		160W		160W	
DIMENSIONS & WEIGHT								
	222(W)x86(H)x363(D)mm; Approx 4.2kg		222(W)x86(H)x363(D)mm; Approx 4.5kg		222(W)x86(H)x363(D)mm; Approx 4.5kg		222(W)x86(H)x363(D)mm; Approx 4.5kg	

Single Output Programmable Linear D.C. Power Supply



PPS-3635



FEATURES

- * Easy Operation with UP/DOWN Key
- * High Resolution: 10mV, 1mA
- * Over Voltage Protection, Over Current Protection (by Hardware)
- * 100 Set Memory
- * Self Test and Software Calibration
- * Auto Step Running With Time Setting
- * FRONT/REAR Output and Sense Switch Selectable
- * IEEE-488.2 and SCPI Compatible Command set
- * LabVIEW Driver Software
- * High Stability, Low Drift
- * 4 Digit Display
- * IEC Safety Regulation

Rear Panel



PPS-3635 is a single output, 126W output, programmable linear DC power supply. OVP and OCP hardware protection, compliance to major safety standards such as UL, CSA, and IEC ensure a high level of safety and reliability. The remote sense adds extra level of precision by compensating cable losses between loads. The SCPI command set and LabVIEW driver access through the GPIB interface provide remote control and ATE software development capability. The flexible PPS-3635 GPIB is ideal for high-level applications requiring high precision and an extra level of safety.

SPECIFICATIONS		
OUTPUT		
Voltage		0 ~ 36V
Current		0 ~ 3.5A
OVP		0 ~ 38.5V
LOAD REGULATION		
Voltage		≤ 3mV rear output (≤ 6mV front output)
Current		≤ 3mA (≤ 6mA rating current > 3.5A)
LINE REGULATION		
Voltage		≤ 3mV
Current		≤ 3mA
RESOLUTION		
Voltage		10mV (20mV rating voltage > 36V)
Current		1mA (2mA rating current > 3.5A)
OVP		10mV (20mV rating voltage > 36V)
PROGRAM ACCURACY (25±5°C)		
Voltage		≤ 0.05% + 25mV (+ 50mV rating voltage > 36 V)
Current		≤ 0.2% + 10mA
OVP		≤ 2% + 0.6V
RIPPLE & NOISE (20Hz ~ 20MHz)		
Voltage		Ripple 1mVrms / 3mVp-p Noise 2mVrms / 30mVp-p
Current		≤ 3mA rms (≤ 5mA rms rating current > 3.5A)
TEMPERATURE COEFFICIENT (0~40°C)		
Voltage		≤ 100ppm + 3mV
Current		≤ 150ppm + 3mA
READBACK RESOLUTION ACCURACY (25±5°C)		
Voltage		10mV (20mV rating voltage > 36V)
Current		1mA (2mA rating current > 3.5A)
Voltage		≤ 0.05% + 25mV (+ 50mV rating voltage > 36V)
Current		≤ 0.2% + 10mA
RESPONSE TIME		
VOLTAGE UP	10% ~ 90%	≤ 100mS
VOLTAGE DOWN	90% ~ 10%	≤ 100mS (≥ 10% rating load)
READBACK TEMPERATURE		
COEFFICIENT	Voltage	≤ 100ppm + 10mV (+ 20mV rating voltage > 36V)
	Current	≤ 150ppm + 10mA
DRIFT	Voltage	≤ 0.03% + 6mV
	Current	≤ 0.1% + 6mA
MEMORY		
Store/Recall		100 sets
TIMER		
Setting Time		1 second ~ 255 minutes (Max. 255 minutes x 100 Sets)
Resolution		1 second
Function		for output working loop (Auto Step running)
INTERFACE		
GPIB Interface Standard		
POWER SOURCE		
AC 100V/120V/ 220V/240V ±10%, 50/60Hz		
DIMENSIONS & WEIGHT		
255(W) x 145(H) x 346(D) mm; Approx. 9.5kg		

ORDERING INFORMATION

PPS-3635 126W Single Output Programmable D.C. Power Supply

ACCESSORIES :

User manualx1, Power cordx1, Test lead GTL-104A x 1

OPTIONAL ACCESSORIES

GRA-401 Rack Adapter Panel, 19" 4U

GTL-248 GPIB Cable, Double Shielded, 2000mm

FREE DOWNLOAD

Driver LabView Driver

Programmable Dual-range Linear D.C. Power Supply



PSM-2010/3004/6003



FEATURES

- * Single Output Dual Range Max. 200W
- * High Resolution: 1mV/1mA
- * Stable & Clear Power: 0.01% Load/Line Regulation, 350 μ Vrms Ripple
- * 100 Sets Memory
- * Auto Step Running With Timer Setting
- * Safety Design: OVP, OCP & OTP ; Output ON/OFF Control(OCP Provides Delay Setting to Prevent Trip of High Start-Up Current)
- * Self-Test and Software Calibration
- * Highly Visible Vacuum-Fluorescent Display
- * Front and Rear Output Terminal
- * Standard Interface : RS-232C, GPIB
- * Optional European Jack Type Terminal

European Type Jack Terminal



Rear Panel



The PSM-Series is single output / dual range, 120W or 200W, programmable linear DC power supplies. OVP, OCP, OTP, and output On/Off control protect the PSM-Series and their load from unexpected conditions. High resolution, high regulation, and low ripple are maintained at 1mV/1mA, 0.01%, and <350 μ Vrms, respectively. Operation and configuration is simplified with a digital interface and a clear LCD display. Standard features include; store/recall output memories, automatic stepping with timers for continuous testing and self-testing and software calibration features to reduce maintenance overhead. SCPI programming, LabVIEW drivers, RS-232C and GPIB interfaces enable easy automated test system integration and remote control. The PSM-Series is an ideal choice for high precision applications such as QA verification and product development.

SPECIFICATIONS			
	PSM-2010	PSM-3004	PSM-6003
DC OUTPUT			
Low Range	0 – 8V/20A	0 – 15V/7A	0 – 30V/6A
High Range	0 – 20V/10A	0 – 30V/4A	0 – 60V/3.3A
CONSTANT VOLTAGE OPERATION			
Regulation (% of output + offset)	Load regulation $\leq 0.01\% + 2mV$; Line regulation $\leq 0.01\% + 2mV$		
Ripple & Noise	< 350 μ Vrms/3mVpp	< 350 μ Vrms/2mVpp	$\leq 50V$: <500 μ Vrms/3mVpp >50V: <1mVrms/3mVpp
CONSTANT CURRENT OPERATION			
Regulation (% of output + offset)	Load regulation $\leq 0.01\% + 250\mu A$; Line regulation $\leq 0.01\% + 250\mu A$		
Ripple & Noise	< 2mArms		
RESOLUTION			
Programming	Voltage Current	1mV 1mA	1mV 0.5mA
Readback	Voltage Current	0.5mV 1mA	0.5mV 0.5mA
Front Panel	Voltage Current	1mV 1mA(<10A), 10mA($\geq 10A$)	
OVP/OCP	Voltage Current	10mV 10mA	
ACCURACY			
Programming	Voltage Current	0.05% + 10mV 0.2% + 10mA	
Readback	Voltage Current	0.05% + 5mV 0.15% + 5mA	
OVP/OCP	Voltage Current	0.1% + 10mV 0.4% + 10mA	
TRANSIENT RESPONSE			
	< 50 μ sec (for output to recover within 15mV following a change in output current from full load to half load)		
COMMAND PROCESSING TIME			
	100 ms		
VOLTAGE PROGRAMMING RESPONSE TIME (for resistive load)(10% ~ 90%)			
Voltage Up	Full Load No Load	95 ms 45 ms	50 ms 20 ms
Voltage Down	Full Load No Load	30 ms 450 ms	45 ms 400 ms
STABILITY (% of output + offset)			
Voltage	0.02% + 1mV		
Current	0.1% + 1mA		
MEMORY			
Store/Recall	100 sets		
TEMPERATURE COEFFICIENT PER °C \pm (% of Output + Offset)			
Voltage	0.01% + 3mV		
Current	0.02% + 3mA		
POWER SOURCE			
AC 100V/120V/220V $\pm 10\%$, 230V (- 6% – + 10%), 50/60Hz			
INTERFACE			
Standard RS-232C, GPIB			
DIMENSIONS & WEIGHT			
230(W) x 140(H) x 380(D) ; Approx. 10kg			

ORDERING INFORMATION

PSM-2010 200W Single Output, Programmable Power Supply
 PSM-6003 200W Single Output, Programmable Power Supply
 PSM-3004 120W Single Output, Programmable Power Supply

ACCESSORIES :

User manual x 1, Power cord x 1, Test lead CTL-104A x 1, European test lead GTL-204A x 1, Ground lead CTL-201A x 1 (European terminal), Sense lead GTL-202 x 1 (European Terminal)

OPTION

Opt. 01 GRA-407 Rack Mount Kit

OPTIONAL ACCESSORIES

CTL-232 RS-232C Cable, 9-pin Female to 9-pin, Null Modem for PC Computer GRA-407 Rack Mount Kit
 CTL-248 GPIB Cable, Double Shielded, 2000mm

FREE DOWNLOAD

PC Software Driver PC Software including Data Log ; Remote Control Software
 Labview Driver ; PSM VB Example ; PSM VC++ Example

Programmable Linear D.C. Power Supply



PSS-2005/3203



FEATURES

- * Digitized Programmable Interface
- * High Resolution 10mV, 1mA
- * High Stability, Low Drift
- * Over-Voltage, Over-Current, Over Temperature Protection
- * Intelligent Fan Control (Change by Output Power)
- * Built-in Buzzer Alarm
- * LabVIEW Driver
- * Standard Interface : RS-232C
- * Optional Interface : GPIB (IEEE-488.2)
- * Optional European Jack Type Terminal

European Type Jack Terminal



Rear Panel



The PSS-Series is single output, 96W or 100W, programmable linear DC power supplies. OVP, OCP, and OTP protect the PSS series and their load from unexpected conditions. The LCD panel simultaneously displays output and other parameters and the regulated cooling fan ensures low noise for comfortable operation. RS232C and GPIB interfaces, SCPI command sets and LABVIEW drivers make remote control and ATE software development easier. (Note: only RS-232C or GPIB can be installed at one time) The compact PSS series is suitable for any high resolution bench-top or rack mount application.

SPECIFICATIONS		
	PSS-2005	PSS-3203
OUTPUT		
Voltage	0 ~ 20V	0 ~ 32V
Current	0 ~ 5A	0 ~ 3A
OVP	0 ~ 21V	0 ~ 33V
LOAD REGULATION		
Voltage	≤ 3mV (≤ 5mV, rating current > 3.0A)	
Current	≤ 3mA (≤ 5mA, rating current > 3.0A)	
LINE REGULATION		
Voltage	≤ 3mV	
Current	≤ 3mA	
RESOLUTION		
Voltage	10mV	
Current	1mA (2mA, rating current > 3.0A)	
OVP	10mV	
PROGRAM ACCURACY (25 ± 5°C)		
Voltage	≤ 0.05%+20mV	
Current	≤ 0.1%+5mA (+10mA, rating current > 3.0A)	
OVP	≤ 0.05%+20mV	
RIPPLE & NOISE (20Hz ~ 20MHz)		
Voltage	Ripple ≤ 1mVrms/3mVp-p ; Noise ≤ 2mVrms/30mVp-p	
Current	≤ 3mA rms (≤ 5mA rms, rating current > 3.0A)	
TEMPERATURE COEFFICIENT (0 ~ 40°C)		
Voltage	≤ 100ppm+3mV	
Current	≤ 100ppm+3mA	
REARBACK RESOLUTION		
Voltage	10mV	
Current	1mA (2mA, rating current > 3.0A)	
REARBACK ACCURACY(25 ± 5°C)		
Voltage	≤ 0.05%+10mV	
Current	≤ 0.1%+5mA (10mA rating current > 3.0A)	
REARBACK TEMPERATURE COEFFICIENT		
Voltage	≤ 100ppm+10mV	
Current	≤ 100ppm+5mA (10mA rating current > 3.0A)	
RESPONSE TIME		
Voltage Up (10%~90%)	≤ 100mS	
Voltage Down (90%~10%)	≤ 100mS (≥10% rating load)	
DRIFT		
Voltage	≤ 100ppm+10mV	
Current	≤ 150ppm+10mA	
INTERFACE		
Standard : RS-232C; Option : GPIB		
POWER SOURCE		
AC 100V/120V/220V±10%, 230V (+10%/−6%), 50/60Hz		
DIMENSIONS & WEIGHT		
108(W) x 142(H) x 318(D) mm, Approx. 4.8kg		

ORDERING INFORMATION

PSS-2005 100W Single Output Programmable D.C. Power Supply

PSS-3203 96W Single Output Programmable D.C. Power Supply

ACCESSORIES :

User manual x 1, Power cord x 1 Test lead GTL-104A x 1 (PSS-2005) or GTL-105A x 1 (PSS-3203)

European Test Lead GTL-204A x 1 (PSS-2005) or GTL-203A x 1 (PSS-3203)

OPTION

Opt.01 : GPIB Interface (factory installed)

OPTIONAL ACCESSORIES

GTL-232 RS-232C Cable, 9-pin Female to 9-pin, null Modem for Computer

GRA-408 Rack Adapter Panel (19" 4U)

CTL-248 GPIB Cable, Double Shielded, 2000mm

FREE DOWNLOAD

PC Software Driver PC Software including Data Log ; Remote Control Software
LabView Driver

Note : When Opt.01 GPIB interface is ordered, the standard interface RS-232C will be deleted.

Switching D.C. Power Supply



The SPS-Series is single output, 360W, switching DC power supply. OVP protects the SPS-Series and their load from unexpected conditions. High regulation is maintained at 0.01%. Remote sensing adds an extra level of precision by compensating cable losses between loads. Turning the output On/Off from external device is available through Remote control terminals. The GPS-Series is an ideal solution for power-efficient bench-top or portable applications requiring high regulation.

SPS-1230/1820/2415/3610/606



FEATURES

- * Dual Measurement Display
- * 0.01 % High Regulation
- * Constant Voltage and Constant Current Operation
- * High Efficiency
- * High Power Density
- * Over Voltage Protection
- * Remote Output ON/OFF Control

Rear Panel



SPECIFICATIONS					
OUTPUT					
	SPS-1230	SPS-1820	SPS-2415	SPS-3610	SPS-606
Voltage	0 ~ 12V	0 ~ 18V	0 ~ 24V	0 ~ 36V	0 ~ 60V
Current	0 ~ 30A	0 ~ 20A	0 ~ 15A	0 ~ 10A	0 ~ 6A
CONSTANT VOLTAGE OPERATION					
Regulation	Line regulation $\leq 5\text{mV}$ Load regulation $\leq 5\text{mV}$				
Ripple & Noise	$\leq 5\text{mVrms}$, 100mVp-p 20Hz ~ 20MHz				
Recovery Time	$\leq 500\mu\text{s}$ (50% Load change, Minimum load 0.5A)				
Temp. Coefficient	$\leq 100\text{ppm}/^\circ\text{C}$				
Output Range	0 to rating voltage continuously adjustable				
CONSTANT CURRENT OPERATION					
Regulation	Line regulation $\leq 3\text{mA}$ Load regulation $\leq 3\text{mA}$				
Ripple Current	$\leq 3\text{mA}_{\text{rms}}$ (SPS-606) $\leq 5\text{mA}_{\text{rms}}$ (SPS-3610) $\leq 10\text{mA}_{\text{rms}}$ (SPS-2415) $\leq 10\text{mA}_{\text{rms}}$ (SPS-1820) $\leq 30\text{mA}_{\text{rms}}$ (SPS-1230)				
Output Range	0 to rating current continuously adjustable (HI/LO range switchable)				
METER					
Type	3 1/2 digit, 0.39" LED display				
Accuracy	$\pm (0.5\% \text{ of rdg} + 2\text{digits})$				
INSULATION					
Chassis and Terminal	20M Ω or above (DC 500V)				
Chassis and AC Cord	30M Ω or above (DC 500V)				
POWER SOURCE					
AC 115V/ 230V $\pm 15\%$, 50/60Hz					
DIMENSIONS & WEIGHT					
128(W) x 151(H) x 295(D) mm, Approx. 3.2kg					

ORDERING INFORMATION

- SPS-1230** 360W Switching D.C. Power Supply
- SPS-1820** 360W Switching D.C. Power Supply
- SPS-2415** 360W Switching D.C. Power Supply
- SPS-3610** 360W Switching D.C. Power Supply
- SPS-606** 360W Switching D.C. Power Supply

ACCESSORIES :

User manual x 1 , Power cord x 1 , Test lead GTL-203A x 1

Linear D.C. Power Supply



The GPR-U Series is single output, 500W to 900W, linear DC power supplies. Overload and reverse polarity protection in addition to OVP/OCP/OTP protect the GPR-U Series and their load from unexpected conditions. High regulation and low ripple/noise are maintained at 0.01% and < 2mVrms, respectively for CV mode. The GPR-U series can be ordered with a customized output requirement from voltage rating from 8W to 1000V and current rating from 0.5–75A (under 1kVA available). The GPR-U Series is the ideal lineup for system applications requiring large output capacity and custom-made output settings, such as material testing and product copper plating.

GPR-U Series

Rear-Panel Output

FEATURES

- * 0.01% High Regulation
- * Constant Voltage and Constant Current Operation
- * Low Ripple and Noise
- * Overload and Reverse Polarity Protection
- * 3 1/2 Digits 0.5" LED Display
- * Application for Material and Products Aging
- * Built-In Overvoltage and Overcurrent Tripped Crowbar
- * Ten-Turn Potentiometer

Rear Panel



GPR-3520HDA



GPR-100H05DA



GPR-3520HDA

SPECIFICATIONS

CONSTANT VOLTAGE OPERATION

Regulation	Line regulation $\leq 0.01\% + 3mV$ Load regulation $\leq 0.01\% + 5mV (<10A)$ $\leq 0.02\% + 5mV (\geq 10A)$
Ripple & Noise	$\leq 2mVrms (5Hz - 1MHz)$
Recovery Time	$\leq 100\mu S (50\% \text{ Load change, Minimum load } 0.5A)$
Output Range	0 to rating voltage continuously adjustable

CONSTANT CURRENT OPERATION

Regulation	Line regulation $\leq 0.2\% + 3mA$ Load regulation $\leq 0.2\% + 3mA$
Ripple Current	$\leq 5mA_{rms} (<20A), \leq 20mA_{rms} (<50A)$ $\leq 100mA_{rms} (<100A)$
Output Range	0 to rating current continuously adjustable

METER

Type	3 1/2 Digits 0.5" LED display
Accuracy	$\pm (0.5\% \text{ of rdg} + 2 \text{ digits})$

INSULATION

Chassis and Terminal	$100M\Omega$ or above (DC 1000V)
Chassis and AC Cord	$100M\Omega$ or above (DC 1000V)

POWER SOURCE

AC 120V $\pm 10\%$, 50/60Hz (AC220V or 240V order made)

DIMENSIONS

430(W) x 178(H) x 572(D) mm

ORDERING INFORMATION

Model	Output Volts(V)	Output Amps(A)	Weight(kg)	External Remote I/O	
GPR-1850HDN	900W D.C. Power Supply	0 ~ 18	0 ~ 50	30	—
GPR-3520HDA	700W D.C. Power Supply	0~35V	0 ~ 20	29.5	—
GPR-6015HDA	900W D.C. Power Supply	0~60V	0 ~ 15	30	—
GPR-7510HDA	750W D.C. Power Supply	0~75V	0 ~ 10	29.5	—
GPR-16H50DA	800W D.C. Power Supply	0~160V	0 ~ 5	30.5	—
GPR-25H30DA	750W D.C. Power Supply	0~250V	0 ~ 3	29.5	—
GPR-35H20DA	700W D.C. Power Supply	0~350V	0 ~ 2	29.5	—
GPR-50H15DA	750W D.C. Power Supply	0~500V	0 ~ 1.5	29.5	—
GPR-60H15DA	900W D.C. Power Supply	0~600V	0 ~ 1.5	30.5	—
GPR-100H05DA	500W D.C. Power Supply	0~1000V	0 ~ 0.5	28.5	—
GPR-7510HDC	750W D.C. Power Supply	0~75V	0 ~ 10	29.5	✓
GPR-6015HDC	900W D.C. Power Supply	0~60V	0 ~ 15	30	✓
GPR-3520HDC	700W D.C. Power Supply	0~35V	0 ~ 20	29.5	✓

ACCESSORIES :

User manual x 1; Test lead GTL-105A x 1 ($\leq 3A$) or GTL-104A x 1 ($\leq 10A$) or Not Available ($> 10A$ or 600V)

OPTIONAL ACCESSORIES

GTL-122 Test Lead, U-type to Alligator Test Lead, Max. Current 40A, 1200mm

Note: Special order 8 volts to 1000 volts and 0.5 Amps to 75 Amps under 1kVA available.

Linear D.C. Power Supply



The GPR-H Series consists of single output linear DC power supplies with voltage outputs rating from 8V to 300V. The series includes overload and reversed polarity protection to protect devices under test from being damaged due to inappropriate operation. The internal select for dynamic loads is often used for amplifier testing. It can support high pulse current derived from dynamic processes as well as support low noise and noise, which make it suitable for high-end bench-top applications requiring precision. Its rear panel supports output wiring. These features combined into one assembly allow the GPR-H Series to predominate in applications requiring high voltage or high current.

GPR-H Series



FEATURES

- * 0.01% High Regulation
- * Constant Voltage and Constant Current Operation
- * Internal Select for Continuous or Dynamic Load
- * Low Ripple and Noise
- * Overload and Reverse Polarity Protection
- * 3 1/2 Digit 0.5" LED Display
- * Internal Select for Continuous or Dynamic Load (for GPR-3510HD/GPR-6060D/GPR-7550D)

SPECIFICATIONS	
CONSTANT VOLTAGE OPERATION	
Regulation	Line regulation $\leq 0.01\% + 3mV$ Load regulation $\leq 0.01\% + 5mV (<10A)$ $\leq 0.02\% + 5mV (\geq 10A)$
Ripple & Noise	$\leq 1mV_{rms}$ 5Hz ~ 1MHz
Recovery Time	$\leq 100\mu S$ (50% load change, minimum load 0.5A)
Output Range	0 to rating voltage continuously adjustable
CONSTANT CURRENT OPERATION	
Regulation	Line regulation $\leq 0.2\% + 3mA$ Load regulation $\leq 0.2\% + 5mA$
Ripple Current	$\leq 5mArms$ ($\leq 20A$), $\leq 10mArms$ ($\leq 30A$) $\leq 20mArms$ ($\leq 50A$)
Output Range	0 to rating current continuously adjustable
METER	
Type	3 1/2 Digit 0.5" LED display
Accuracy	$\pm (0.5\% \text{ of rdg} + 2 \text{ digits})$
INSULATION	
Chassis and Terminal	100M Ω or above (DC 1000V)
Chassis and AC Cord	100M Ω or above (DC 1000V)
POWER SOURCE	
AC 100V/120V/220V/240V $\pm 10\%$, 50/60Hz	
DIMENSIONS	
254(W) x 152(H) x 456(D) mm	

Rear Panel



ORDERING INFORMATION				
Model		Output Volts (V)	Output Amps (A)	Weight (kg)
GPR-0830HD	240W D.C. Power Supply	0 ~ 8	0 ~ 30	18.5
GPR-1820HD	360W D.C. Power Supply	0 ~ 18	0 ~ 20	18.5
GPR-3510HD	350W D.C. Power Supply	0 ~ 35	0 ~ 10	18.5
GPR-6060D	360W D.C. Power Supply	0 ~ 60	0 ~ 6	18.5
GPR-7550D	375W D.C. Power Supply	0 ~ 75	0 ~ 5	18.5
GPR-11H30D	330W D.C. Power Supply	0 ~ 110	0 ~ 3	13.5
GPR-30H10D	300W D.C. Power Supply	0 ~ 300	0 ~ 1	13.5
ACCESSORIES :				
User manual x 1, Power cord x 1				
Test lead GTL-105A x 1 ($\leq 3A$) or GTL-104A x 1 ($\leq 10A$) or Not Available ($>10A$)				
OPTIONAL ACCESSORIES				
CTL-122	Test Lead, U-type to Alligator Test Lead, Max. Current 40A, 1200mm			

Note: **CE** Approved Only for GPR-1820HD, GPR-3510HD, GPR-7550D, GPR-11H30D
Rear-Panel Output Only for GPR-0830HD, GPR-1820HD

Linear D.C. Power Supply



The GPR-M Series is single output, 180W, linear DC power supplies which featuring all the same functions as the GPR-H Series but for lower power demands. Like the GPR-H Series, the GPR-M Series is suitable for high-end precision bench top applications. Low load and line regulation for both constant voltage and constant current mode ensure reliable, predictable output. Overload and reverse polarity protection as well as internal selection for dynamic or constant load are standard.

GPR-M Series



FEATURES

- * 0.01% High Regulation
- * Constant Voltage and Constant Current Operation
- * Internal Select for Continuous or Dynamic Load
- * Low Ripple and Noise
- * Overload and Reverse Polarity protection
- * 3 1/2 Digit 0.5" LED Display

SPECIFICATIONS

CONSTANT VOLTAGE OPERATION

Regulation	Line regulation $\leq 0.01\% + 3mV$ Load regulation $\leq 0.01\% + 5mV (<10A)$ Load regulation $\leq 0.02\% + 5mV (\geq 10A)$
Ripple & Noise	$\leq 1mV_{rms}$ 5Hz ~ 1MHz
Recovery Time	$\leq 100\mu S$ (50% load change, minimum load 0.5A)
Output Range	0 to rating voltage continuously adjustable

CONSTANT CURRENT OPERATION

Regulation	Line regulation $\leq 0.2\% + 3mA$ Load regulation $\leq 0.2\% + 3mA$
Ripple Current	$\leq 3mA_{rms}$
Output Range	0 to rating current continuously adjustable

METER

Digital	3 1/2 Digits 0.5" LED display Accuracy $\pm (0.5\% \text{ of rdg } + 2 \text{ digits })$
---------	---

INSULATION

Chassis and Terminal	20M Ω or above (DC 500V)
Chassis and AC Cord	30M Ω or above (DC 500V)

POWER SOURCE

AC 100V/120V/220V/240V $\pm 10\%$, 50/60Hz

DIMENSIONS

254(W) x 152(H) x 349(D) mm

ORDERING INFORMATION

Model	Output Volts (V)	Output Amps (A)	Weight (kg)
GPR-1810HD 180W D.C. Power Supply	0 ~ 18	0 ~ 10	11.5
GPR-3060D 180W D.C. Power Supply	0 ~ 30	0 ~ 6	11.5
GPR-6030D 180W D.C. Power Supply	0 ~ 60	0 ~ 3	11.5

ACCESSORIES :

User manual x 1 , Power cord x 1
Test lead GTL-105A x 1 (GPR-6030D)
GTL-104A x 1 (GPR-1810HD/3060D)

OPTIONAL ACCESSORIES

GRA-401 Rack Adapter Panel (19" , 4U)

Linear D.C. Power Supply



GPS-1830D/1850D/3030D



GPS-3030



GPS-3030DD



The GPS-Series is single output, 54W to 90W, linear DC power supplies. The GPS-Series includes both analog and digital display meters with varying power outputs. The GPS-Series features overload and reverse polarity protection as well as high regulation and low ripple/noise that are maintained at 0.01% and < 1mVrms, respectively. Continuous or dynamic internal load selection accommodates applications such as pulsed current. Remote control terminals offer programming and operation from an external device.

SPECIFICATIONS	
CONSTANT VOLTAGE OPERATION	
Regulation	Line regulation $\leq 0.01\% + 3mV$ Load regulation $\leq 0.01\% + 3mV$ (rating current $\leq 3A$) $\leq 0.01\% + 5mV$ (rating current $> 3A$)
Ripple & Noise	$\leq 0.5mVrms$ 5Hz – 1MHz (rating current $\leq 3A$) $\leq 1mVrms$ 5Hz – 1MHz (rating current $> 3A$)
Recovery Time	$\leq 100\mu S$ (50% load change, minimum load 0.5A)
Temp. Coefficient	$\leq 300 ppm / ^\circ C$
Output Range	0 to rating voltage continuously adjustable
CONSTANT CURRENT OPERATION	
Regulation	Line regulation $\leq 0.2\% + 3mA$ Load regulation $\leq 0.2\% + 3mA$
Ripple Current	$\leq 3mA rms$
Output Range	0 to rating current continuously adjustable (Hi / Lo range switchable)
METER	
Analog	V-meter and I-meter 2.5 class Dimensions 50 x 50 mm
Digital	3 1/2 digits 0.5" LED display (GPS-1830D/1850D/3030D) 3 1/2 digits 0.39" LED display (GPS-3030DD) Accuracy $\pm (0.5\% \text{ of rdg} + 2 \text{ digits})$
INSULATION	
Chassis and Terminal	20M Ω or above (DC 500V)
Chassis and AC Cord	30M Ω or above (DC 500V)
POWER SOURCE	
AC 100V/120V/220V/240V $\pm 10\%$, 50/60Hz	
DIMENSIONS	
128(W) x 145(H) x 285(D) mm	

FEATURES

- * Light and Compact Design
- * 0.01% High Regulation
- * Constant Voltage and Constant Current Operation
- * Remote Control for External Programmability
- * Internal Select for Continuous or Dynamic Load
- * Low Ripple and Noise
- * Overload and Reverse Polarity Protection
- * Series or Parallel Operation
- * Optional European Type Jack Terminal for GPS-3030/GPS-3030D/GPS-3030DD

European Type Jack Terminal



ORDERING INFORMATION					
	Model	Output Volts(V)	Output Amps(A)	Weight (kg)	
	GPS-3030	90W D.C. Power Supply	0 – 30	0 – 3	5
	GPS-1830D	54W D.C. Power Supply	0 – 18	0 – 3	4
	GPS-1850D	90W D.C. Power Supply	0 – 18	0 – 5	5
	GPS-3030D	90W D.C. Power Supply	0 – 30	0 – 3	5
	GPS-3030DD	90W D.C. Power Supply	0 – 30	0 – 3	5
ACCESSORIES :					
User manual x 1 , Power cord x 1					
Test lead GTL-105A x 1 ($\leq 3A$) or GTL-104A x 1 ($\leq 10A$)					
European test lead GTL-203A x 1 ($\leq 3A$) or GTL-204A x 1 ($\leq 10A$)					

Multiple Output Programmable Linear D.C. Power Supply



PPE-3323



PPT-1830/PPT-3615



FEATURES

- * Easy Operation with UP/DOWN Key
- * High Resolution: 10mV, 1mA
- * Over Voltage Protection, Over Current Protection (PPT-Series by Hardware, PPE-Series by Software)
- * 50 Sets Memory
- * Self Test and Software Calibration
- * Auto Step Running With Timer Setting
- * FRONT/REAR Output and Sense Switch Selectable (PPT-Series)
- * Triple Output
- * Auto Series and Parallel Operation (PPT-Series)
- * Auto Tracking
- * IEEE-488.2 and SCPI Compatible Command set (PPT-Series)
- * RS-232C Communication (PPE-3323)
- * GPIB Standard Interface (PPT-Series)
- * LabVIEW Driver Software (PPT-Series)
- * High Stability, Low Drift
- * 4 Digit Display
- * IEC Safety Regulation

Rear Panel



PPE-3323



PPT-1830

The PPE/PPT-Series are 3-channel, programmable linear DC power supplies with 207W, 138W or 126W outputs. The PPE/PPT-Series feature OVP and OCP and are compliant with all major safety standards (UL, CSA, and IEC) for safe, reliable operation. For extra precision the PPT series includes remote sensing that adds an extra level of precision by compensating cable losses between loads. The digital interface and smart features simplify operation and configuration with output limit store/recall functions, automatic tracking, automatic serial or parallel operation (PPT-Series), and auto stepping for continuous testing. The series have Labview drivers and SCPI commands as standard for remote control and PC interfacing via RS232 (PPE-3323) and GPIB (PPT-Series). The versatile PPE/PPT-Series are ideal for high-level applications requiring high resolution, multiple outputs, and an extra level of safety.

SPECIFICATIONS			
MODEL	PPE-3323	PPT-1830	PPT-3615
OUTPUT			
Voltage	0~+32V, 0~-32V, 3.3V/5V FIXED	0~18Vx2, 0~6Vx1	0~36Vx2, 0~6Vx1
Current	0~+3A, 0~-3A, 3A FIXED	0~3Ax2, 0~5Ax1	0~1.5Ax2, 0~3Ax1
OVP	0~+33V, 0~-33V	0~20Vx2, 0~7Vx1	0~38.5Vx2, 0~7Vx1
LOAD REGULATION			
Voltage	≤6mV	≤3mV rear output (≤6mV front output)	
Current	≤3mA	≤3mA (≤6mA rating current > 3.5A)	
LINE REGULATION			
Voltage	≤3mV		
Current	≤3mA		
RESOLUTION			
Voltage	10mV (20mV rating voltage > 36V)		
Current	1mA (2mA rating current > 3.5A)		
OVP	10mV (20mV rating voltage > 36V)		
PROGRAM ACCURACY (25±5°C)			
Voltage	≤0.05% + 25mV (+ 50mV rating voltage > 36V)		
Current	≤0.2% + 10mA		
OVP	≤2% + 0.6V		
RIPPLE & NOISE (20Hz ~ 20MHz)			
Voltage	Ripple 1mVrms / 3mVp-p		
Current	Noise 2mVrms / 30mVp-p		
	≤3mA rms (≤5mA rms rating current > 3.5A)		
TEMPERATURE COEFFICIENT (0~40°C)			
Voltage	≤100ppm + 3mV		
Current	≤150ppm + 3mA		
REARBACK RESOLUTION/ACCURACY (25±5°C)			
Voltage	10mV (20mV rating voltage > 36V)		
Current	1mA (2mA rating current > 3.5A)		
Voltage	≤0.05% + 25mV (+ 50mV rating voltage > 36V)		
Current	≤0.2% + 10mA		
RESPONSE TIME			
VOLTAGE UP 10% ~ 90%	≤100mS		
VOLTAGE DOWN 90% ~ 10%	≤100mS (≥ rating load)		
REARBACK TEMPERATURE COEFFICIENT			
Voltage	≤100ppm + 10mV (+ 20mV rating voltage > 36V)		
Current	≤150ppm + 10mA		
DRIFT			
Voltage	≤100ppm + 10mV		
Current	≤150ppm + 10mA		
	≤0.03% + 6mV		
	≤0.1% + 6mA		
TRACK OPERATION			
Tracking Error	≤0.1% + 50mV		
Series Regulation	≤50mV		
PARALLEL OPERATION (PPT-Series only)			
Program Accuracy (25±5°C)	Voltage	≤0.05% + 25mV (+ 50mV rating voltage > 36V)	
	Current	≤0.2% + 20mA	
	OVP	≤2% + 0.6V	
Load Effect	Voltage	≤3mV rear output (≤ 6mV front output)	
	Current	≤6mA (≤12mA rating current > 3.5A)	
Source Effect	Voltage	≤3mV ; Current ≤6mA	
MEMORY			
Store/Recall	50 sets		
TIMER			
Setting Time	1 second ~ 255 minutes (Max. 255 minutes x 50 sets for PPT-Series)		
	1 second ~ 99 minutes (Max. 99 minutes x 50 sets for PPE-3323)		
Resolution	1 second		
Function	for output working loop (Auto Step running)		
STANDARD INTERFACE			
RS-232C for PPE-Series; GPIB for PPT-Series			
POWER SOURCE			
AC 100V/120V/220V/240V ±10%, 50/60Hz			
DIMENSIONS & WEIGHT			
255 (W) x 145 (H) x 346 (D) mm; Approx. 10kg			

ORDERING INFORMATION

- PPE-3323 207W Triple Output Programmable D.C. Power Supply
- PPT-1830 138W Triple Output Programmable D.C. Power Supply
- PPT-3615 126W Triple Output Programmable D.C. Power Supply

Model	Independent	Series	Parallel	Display Type	Weight (kg)
PPE-3323	(0~32V/0~3A)x2, (5V/3A)FIXED	64V/3A	32V/6A	LED	10
PPT-1830	(0~18V/0~3A)x2, (0~6V/0~5A)x1	36V/3A	18V/6A	LED	10
PPT-3615	(0~36V/0~1.5A)x2, (0~6V/0~3A)x1	72V/1.5A	36V/3A	LED	10

ACCESSORIES:

User manual x 1, Power cord x 1, Test lead GTL-105A x 3 (PPE-3323 & PPT-3615), GTL-104A x 3 (PPT-1830)

OPTIONAL ACCESSORIES

GRA-401 Rack Mount Kit
 CTL-248 GPIB Cable, Double Shielded, 2000mm
 GTL-204A European test lead x 3 (for PPT-1830/PPT-3615)

FREE DOWNLOAD

PPE-3323 PC Software Remote Control Software PPT-1830, PPT-3615 Driver LabView Driver

PPE-3323/PPT-1830/PPT-3615

POWER SUPPLIES

Multiple Output Programmable Linear D.C. Power Supply



PST-3201/3202



FEATURES

- * Digitized Programmable Interface
- * High Resolution 10mV, 1mA
- * 192 x 128 LCD Display, Simultaneously Shows Settings and Measuring Result
- * Over-Voltage, Over-Current, Over Temperature Protection
- * Intelligent Fan Control (Changes by Output Power)
- * 100 Sets Memory
- * Auto Step Running With Timer Setting
- * Auto Series and Parallel Function
- * LabVIEW Driver
- * Standard Interface : RS-232C
- * Optional Interface : GPIB (IEEE-488.2)
- * Optional European Jack Type Terminal

European Type Jack Terminal



Rear Panel



PST series is 3-channel, 96W or 158W, programmable linear DC power supplies. High resolution is maintained at 10mV, 1mA (3A). OVP, OCP, and OTP protect the PST-Series and its loads from unexpected conditions. PST-Series is capable of independent, series or parallel operation for increased flexibility. The large LCD display conveniently displays all outputs and configurations simultaneously to simplify operation. The programmable interface allows automatic stepping, 100 sets of memory and comprehensive timing operations. GPIB and RS232C interfaces, Labview drivers and SCPI compatibility allow easy ATE software development and remote control. The versatile PST-Series is ideal for high resolution, multiple output, automated operations such as production testing and rack mounting systems.

SPECIFICATIONS		
	PST-3202	PST-3201
OUTPUT		
Voltage	0~32Vx2, 0~6Vx1	0~32Vx3
Current	0~2Ax2, 0~5Ax1	0~1Ax3
OVP	0~33Vx2, 0~7Vx1	0~33Vx3
LOAD REGULATION		
Voltage	≤ 3mV (≤ 5mV rating current >3.0A)	
Current	≤ 3mA (≤ 5mA rating current >3.0A)	
LINE REGULATION		
Voltage	≤ 3mV	
Current	≤ 3mA	
RESOLUTION		
Voltage	10mV	
Current	1mA (2mA, rating current >3.0A)	
OVP	10mV	
PROGRAM ACCURACY(25 ± 5 °C)		
Voltage	≤ 0.05%+20mV	
Current	≤ 0.1%+5mA (+10mA, rating current>3.0A)	
OVP	≤ 0.05%+20mV	
RIPPLE & NOISE(20Hz~20MHz)		
Voltage	Ripple: ≤ 1mVrms/3mVp-p ; Noise: ≤ 2mVrms/30mVp-p	
Current	≤ 3mArms (≤ 5mArms, rating current >3.0A)	
TEMPERATURE COEFFICIENT (0 - 40 °C)		
Voltage	≤ 100ppm+3mV	
Current	≤ 100ppm+3mA	
REARBACK RESOLUTION		
Voltage	10mV(20mV, rating voltage >36V)	
Current	1mA(2mA, rating current >3.0A)	
REARBACK ACCURACY(25 ± 5 °C)		
Voltage	≤ 0.05%+10mV(+20mV, rating voltage >36V)	
Current	≤ 0.1%+5mA(+10mA, rating current>3.0A)	
REARBACK TEMPERATURE COEFFICIENT		
Voltage	≤ 100ppm+10mV(+20mV, rating voltage >36V)	
Current	≤ 150ppm+10mA(+20mA, rating current >3.0A)	
RESPONSE TIME		
Voltage Up (10%~90%)	≤ 100mS	
Voltage Down (90%~10%)	≤ 100mS (≥ 10% rating load)	
DRIFT		
Voltage	≤ 100ppm+10mV(+20mV, rating voltage >36V)	
Current	≤ 150ppm+10mA	
TRACK OPERATION		
Tracking Error	≤ 0.1%+20mV	
Series(Load Effect)	≤ 20mV	
PARALLEL OPERATION		
Program Accuracy(25±5°C)	Voltage ≤ 0.05%+20mV, Current ≤ 0.1%+10mA, OVP ≤ 0.05%+20mV	
Load Effect	Voltage ≤ 3mV(≤ 5mV, rating current>3.0A); Current ≤ 6mA	
Source Effect	Voltage ≤ 3mV; Current ≤ 6mA	
MEMORY		
Store/Recall	100 Sets	
TIMER		
Setting Time	0.1 second~99 Minutes 59 second (Max. 99 Minutes 59 second x 100)	
Resolution	0.1 second	
Function	Auto step running (for output working loop)	
INTERFACE		
Standard : RS-232C ; Option: GPIB (IEEE488.2)		
POWER SOURCE		
AC 100V/120V/220V ± 10%, 230V(+10%/-6%), 50/60Hz		
DIMENSIONS & WEIGHT		
230(W) x 140(H) x 380(D) mm , Approx.10kg		

ORDERING INFORMATION

PST-3202 158W Triple Output Programmable D.C. Power Supply

PST-3201 96W Triple Output Programmable D.C. Power Supply

Model	Independent	Series	Parallel	Display Type	Weight (kg)
PST-3201	(0~32V/0~1A)x3	64V/1A	32V/2A	LCD	10
PST-3202	(0~32V/0~2A)x2, (0~6V/0~5A)x1	64V/2A	32V/4A	LCD	10

ACCESSORIES :

User manual x 1, Power cord x 1, Test lead: GTL-104A x 3 (PST-3202) or GTL-105A x 3 (PST-3201)
European test lead: GTL-204A x 3 (PST-3202) or GTL-203A x 3 (PST-3201)

OPTION

Opt.01 GPIB Interface (factory installed)

OPTIONAL ACCESSORIES

GRA-407 Rack Mount Kit
GTL-248 GPIB Cable, Double Shielded, 2000mm
GTL-232 RS-232C Cable, 9-pin Female to 9-pin, null Modem for Computer

FREE DOWNLOAD

PC Software PC Software including Data Log ; Remote Control Software
Driver LabView Driver

Multiple Output Programmable Linear D.C. Power Supply



GPD-2303S/3303S/ 4303S/3303D



FEATURES

- * 2, 3 and 4 Independent Isolated Output
- * 4 LED Display Sets : 3 Digits After Decimal Point (GPD-2303S/3303S/4303S)
- * Minimum Resolution :
GPD-2303S/3303S/4303S (1mV/1mA)
GPD-3303D (100mV/10mA)
- * Digital Panel Control (Rotary Encoder Switch, Rubber Key With Indicator)
- * User-Friendly Operation, Coarse / Fine Volume Control
- * 4 Sets Save / Recall
- * Key-Lock
- * Output ON/OFF
- * Tracking Series and Parallel Mode
- * Smart Cooling Fan Achieving Low Noise
- * Compact Design
- * PC Software & USB Driver
- * USB Standard Interface
- * Optional European Jack Type Terminal

European Type Jack Terminal



Rear Panel



The GPD-Series is cutting edge, economical, high resolution programmable power supplies. They are equipped with 2, 3 and 4 independent output channels and support a maximum output from 180Watt to 195Watt. The power supplies include four sets of memory for voltage and current setting, a USB remote interface, high resolution (GPD-2303S / GPD-3303S / GPD-4303S) and intelligent fan control to reduce noise. The durable features along with the free output monitoring software make the GPD-Series suitable for any lab as well as the LED industry.

SPECIFICATIONS												
	GPD-2303S		GPD-3303S			GPD-4303S			GPD-3303D			
OUTPUT												
Channel	CH1	CH2	CH1	CH2	CH3	CH1	CH2	CH3	CH4	CH1	CH2	CH3
Voltage	0-30V	0-30V	0-30V	0-30V	2.5/3.3/5.0V	0-30V	0-30V	0-5V or 5.001V-10V	0-5V	0-30V	0-30V	2.5/3.3/5.0V
Current	0-3A	0-3A	0-3A	0-3A	0-3A	0-3A	0-3A	0-3A or 0-1A	0-1A	0-3A	0-3A	0-3A
CONSTANT VOLTAGE OPERATION												
Regulation	Line regulation $\leq 0.01\%+3mV$ Load regulation $\leq 0.01\%+3mV$ (rating current $\leq 3A$); $\leq 0.02\%+5mV$ (rating current $>3A$)											
Ripple & Noise	$\leq 1mVrms$ (5Hz-1MHz)											
Recovery Time	$\leq 100\mu s$ (50%Load change, Minimum load 0.5A)											
Temp.Coefficient	$\leq 300ppm / ^\circ C$											
Output Range	0 to rating voltage continuously adjustable											
CONSTANT CURRENT OPERATION												
Regulation	Line regulation $\leq 0.2\%+3mA$; Load regulation $\leq 0.2\%+3mA$											
Ripple Current	$\leq 3mA$ Arms											
Output Range	0 to rating current continuously adjustable											
TRACKING OPERATION												
Regulation of PAR.	Line regulation $\leq 0.01\%+3mV$ Load regulation $\leq 0.01\%+3mV$ (rating current $\leq 3A$); $\leq 0.02\%+5mV$ (rating current $>3A$)											
Regulation of SER.	Line regulation $\leq 0.01\%+5mV$ Load regulation $\leq 300mV$											
Tracking Error	$\leq 0.5\% \pm 10mV$ (10-30V no load) with load added $\leq 300mV$ $\leq 0.5\% \pm 30mV$ (0-9.99V no load) with load added $\leq 300mV$											
METER												
Tracking error	$\leq 0.5\% + 10mV$											
Display	Voltage: 4 3/4 digits 0.4" LED Display Current: 3 3/4 digits 0.4" LED Display								$\leq 0.5\% + 50mV$ Voltage: 2 3/4 digits 0.4" LED Display Current: 2 3/4 digits 0.4" LED Display			
Resolution	Voltage: 1mV Current: 1mA								Voltage: 100mV Current: 10mA			
Program Accuracy (25 \pm 5 $^\circ$ C)	Voltage: $\pm(0.03\%$ of RDG +10 digits) Current: $\pm(0.3\%$ of RDC +10 digits)								Voltage: $\pm(0.5\%$ of RDG+2 digits) Current: $\pm(0.5\%$ of RDG+2 digits)			
Readback Accuracy (25 \pm 5 $^\circ$ C)	Voltage: $\pm(0.03\%$ of RDG +10 digits) Current: $\pm(0.3\%$ of RDC +10 digits)								Voltage: $\pm(0.5\%$ of RDG+2 digits) Current: $\pm(0.5\%$ of RDG+2 digits)			
CH3 SPECIFICATIONS												
Output Voltage					(2.5V/3.3V/5V) $\pm 8\%$	0-5V / 5-10V			(2.5V/3.3V/5V) $\pm 8\%$			
Output Current					3A	0-3A / 0-1A			3A			
Regulation (25 \pm 5 $^\circ$ C)	-				Line regulation $\leq 0.01\%+3mV$ Load regulation $\leq 0.01\%+3mV$	Line regulation $\leq 0.01\%+3mV$ Load regulation $\leq 0.01\%+3mV$			Line regulation $\leq 0.01\%+3mV$ Load regulation $\leq 0.01\%+3mV$			
Repple & Noise					$\leq 1mVrms$ (5Hz-1MHz)	$\leq 2mVrms$ (5Hz-1MHz)			$\leq 1mVrms$ (5Hz-1MHz)			
KEY LOCK												
Yes												
MEMERY SAVE/RECALL												
4 sets												
POWER SOURCE												
AC100V/120V/220V/230V $\pm 10\%$, 50/60Hz												
DIMENSION & WEIGHT												
210(W) x 130 (H) x 265 (D) mm ; Approx. 7kg												

ORDERING INFORMATION

- GPD-2303S GPD-2303S 2 Channels, 180W Programmable Linear DC Power Supply
- GPD-3303S GPD-3303S 3 Channels, 195W Programmable Linear DC Power Supply
- GPD-4303S GPD-4303S 4 Channels, 195W Programmable Linear DC Power Supply
- GPD-3303D GPD-3303D 3 Channels, 195W Programmable Linear DC Power Supply

ACCESSORIES :

User Manual x 1, Power cord x 1

GPD-2303S Test Lead GTL-104A x 2, European Test Lead GTL-204Ax2, GTL-201A x 1

GPD-3303S Test Lead GTL-104A x 2, GTL-105A x 1; European Test Lead GTL-203A x 1, GTL-204A x 2, GTL-201A x 1

GPD-4303S Test Lead GTL-104A x 2, GTL-105A x 2; European Test Lead GTL-203A x 2, GTL-204A x 2, GTL-201A x 1

GPD-3303D Test Lead GTL-104A x 2, GTL-105A x 1; European Test Lead GTL-203A x 1, GTL-204A x 2, GTL-201A x 1

OPTIONAL ACCESSORIES

GTL-246 USB Cable

FREE DOWNLOAD

PC Software PC Software including Data Log
Driver Labview Driver

Multi-output Programmable D.C. Power Supply



GPP-Series

NEW



FEATURES

- * 4.3" TFT LCD Display
- * Supports Setting Value, Measurement Value and Output Waveform Display
- * Load Function (CC, CV, CR Mode)
- * Setting Resolution: 1mV/0.1mA ; Read Back Resolution: 0.1mV/0.1mA
- * Low Ripple Noise: $\leq 350\text{mVrms}/\leq 2\text{mArms}$
- * Transient Response Time: $\leq 50\text{ms}$
- * Tracking Series and Parallel Function without Additional External Wiring
- * Utilizing Hardware to Realize Over Voltage Protection/Over Current Protection/Over Temperature Protection
- * Delay Function/Output Monitoring Function/Output Recorder Function
- * Intelligent Temperature Control Fan Effectively Reduces Noise
- * Sequential Output Function and Built-in 8 Template Waveforms
- * The Output Recorder Function Records The Output Voltage & Current Parameters with A Minimum Recording Interval of 1 Second
- * Provides 10 Sets of Memory for Each Sequence /Delay/Recorder/Panel Setting Condition
- * GPP-3323 Supports A USB(Type A) Output Terminal
- * Standard: RS-232, USB, Ext I/O; Optional (Manufacturer Installed Only) : LAN, GPIB+LAN
- * Compatible with Commands of GPD-X303S Series

With the maximum output power of 217W, the GPP-Series, the multi-channel programmable DC power supply, includes four models: GPP-1326 (0-32V/0-6A) for single-channel output and GPP-2323 for dual-channel output (CH1: 0-32V/0-3A, CH2: 0-32V/0-3A), GPP-3323 for three-channel output (CH1: 0-32V/0-3A, CH2: 0-32V/0-3A, CH3: 1.8V, 2.5V, 3.3V, 5.0V/5A) and GPP-4323 for four-channel output (CH1: 0-32V/0-3A, CH2: 0-32V/0-3A, CH3: 0-5V/0-1A, CH4: 0-15V/0-1A). This series not only provides high program resolution (1mV/0.1mA) and read back resolution (0.1mV/0.1mA), but also features optimal low-ripple noise characteristics $\leq 350\text{mVrms}/\leq 2\text{mArms}$ and output transient recovery capability $\leq 50\mu\text{s}$. Independent output on-off switch is provided for each channel.

For series and parallel applications of CH1 and CH2, the tracking function of the GPP-Series utilizes the internal circuit to automatically switch the output to serial or parallel output without additional external wiring, providing users with convenience not only in operating procedures but also a more stable output. The tracking function design of other brands requires additional external wiring connections for the output in series or parallel. However, excessively long, thin or inconsistent external wiring may cause inaccurate voltage or current output.

The GPP-Series offers a variety of display modes, including single or multi-channel setting values, measurement values, and waveform displays. The Monitor function of the GPP-Series allows users to set monitoring conditions according to requirements, sound alarms or stop output during the measurement process, and stop measurement and protect the customer's DUT. The GPP-Series provides output recorder function, which records the voltage/current of the output process to the internal memory, and the result can be stored as a (*.REC) or (*.CSV) file, which can then be transferred to the USB flash drive. The stored *.CSV can be exported to the Excel to conduct the future analysis.

The CH1/CH2 of the GPP-Series are designed with the load function. A single power supply can set one channel as the power output, and one channel for the load function to consume the power of the DUT so as to meet the basic charging and discharging test requirements for battery. Channel 1 and channel 2 not only provide 32V/3A power output, but also feature built-in maximum 32V constant voltage load (CV), maximum 3.2A constant current load (CC) and maximum 1k Ω constant resistance load (CR) function.

The GPP-Series provides the sequential output function on Channel 1 and Channel 2. This function not only allows users to edit the power output waveform, but also allows users to set the sequential constant voltage (CV) or constant current (CC) load waveform, i.e. a serial power output or a simulation test of a dynamic load. In order to simplify the setting of waveform editing, the GPP-Series has 8 built-in Template waveforms in the sequence output function for users to directly apply for output, including Sine, Pulse, Ramp, Stair Up, Stair Dn, Stair UpDn, Exp Rise, Exp Fall waveforms.

The sound protection functions include OVP/OCP/OPP/OTP, in which the protection mechanism for OVP/OCP/OTP is implemented by hardware circuit that has the advantage of faster response time compared with competitors who adopt software to achieve protections. The OVP/OCP functions allow users to set the protection action point (except CH3 of GPP-3323) according to the conditions of the DUT. The OPP is only activated during the operation of the load function. The Delay Function sets the length of time during channel 1 or channel 2 power output on or during power output off.

In addition, the Trigger In/ Trigger Out functions synchronize external devices. The GPP-3323 channel 3 adds a 3A USB (Type A) output terminal for USB charging test. The intelligent temperature-controlled fan can adjust the speed according to the temperature of the power transistor so as to reduce unnecessary noise. The output value setting and the Sequence/Delay/Recorder functions provide 10 sets of internal memory for use, and can be loaded/stored using a USB flash drive. In addition to the standard RS-232 and USB remote interfaces, the GPP-Series also has an optional LAN or LAN+GPIB interface to facilitate different requirements. The commands of the GPP-Series conform to SCPI requirements and are compatible with the commands of the GPD-X303S Series.

SPECIFICATIONS										
	GPP-4323				GPP-3323			GPP-2323		GPP-1326
OUTPUT MODE										
Number of Channel	CH1	CH2	CH3	CH4	CH1	CH2	CH3	CH1	CH2	CH1
	0-32V	0-32V	0-5V	0-15V	0-32V	0-32V	1.8/2.5/3.3/5.0V	0-32V	0-32V	0-32V
Current	0-3A	0-3A	0-1A	0-1A	0-3A	0-3A	5A	0-3A	0-3A	0-6A
Tracking Series Voltage	0-64V				0-64V				0-64V	
Tracking Parallel Current	0-6A				0-6A					
CONSTANT VOLTAGE OPERATION										
Line Regulation	$\leq 0.01\%+3\text{mV}$									
Load Regulation	$\leq 0.01\%+3\text{mV}(\text{rating current} \leq 3\text{A}); \leq 0.02\%+5\text{mV}(\text{rating current} > 3\text{A})$									
Ripple & Noise(5Hz-1MHz)	$\leq 350\mu\text{Vrms}$		$\leq 1\text{mVrms}$		$\leq 350\mu\text{Vrms}$		$\leq 2\text{mVrms}$		$\leq 350\mu\text{Vrms}$	
Recovery Time	$\leq 50\mu\text{s}$		$\leq 50\mu\text{s}$		$\leq 50\mu\text{s}$		$\leq 100\mu\text{s}$		$\leq 50\mu\text{s}$	
CONSTANT CURRENT OPERATION										
Line Regulation	$\leq 0.2\%+3\text{mA}$									
Load Regulation	$\leq 0.2\%+3\text{mA}$									
Ripple & Noise	$\leq 2\text{mArms}$				$\leq 2\text{mArms}$			$\leq 2\text{mArms}$		$\leq 4\text{mArms}$
PROGRAMMING RESOLUTION										
Voltage	1mV				1mV			1mV		1mV
Current	0.1mA				0.1mA			0.1mA		0.2mA
TRACKING OPERATION (CH1,CH2)										
Tracking Error	$\leq 0.1\%+10\text{mV}$ of Master(0-32V, No Load, with Load add Load regulation $\leq 100\text{mV}$)									
Parallel Regulation	Line : $\leq 0.01\%+3\text{mV}$									
	Load : $\leq 0.01\%+3\text{mV}(\text{rating current} \leq 3\text{A}); \leq 0.02\%+5\text{mV}(\text{rating current} > 3\text{A})$									
Series Regulation	Line : $\leq 0.01\%+5\text{mV}$; Load : $\leq 100\text{mV}$									
Ripple & Noise	$\leq 1\text{mVrms}$, 5Hz - 1MHz									
Ch3 OPERATION FOR (GPP-3323)										
Output Voltage	1.8V/2.5V/3.3V/5.0V, $\pm 5\%$									
Output Current	5A									
Line Regulation	$\leq 3\text{mV}$									
Load Regulation	$\leq 5\text{mV}$									
Ripple & Noise	2mVrms(5Hz-1MHz)									
Transient Recovery Time	100 μs									
USB Port Output	1.8V/2.5V/3.3V/5.0V, $\pm 0.35\text{V}$, 3A									

Multi-output Programmable D.C. Power Supply

Rear Panel (LAN+GPIB)



Rear Panel (LAN)



Rear Panel



GPP-1326



GPP-2323



GPP-3323



GPP-4323

SPECIFICATIONS				
	GPP-4323	GPP-3323	GPP-2323	GPP-1326
METER				
Voltage Resolution	0.1mV	0.1mV	0.1mV	0.1mV
Current Resolution	0.1mA	0.1mA	0.1mA	0.2mA
Setting Accuracy	$\leq \pm(0.03\%+10mV)$	$\leq \pm(0.03\%+10mV)$	-	$\leq \pm(0.03\%+10mV)$
Readback Accuracy	$\leq \pm(0.30\%+10mA)$	$\leq \pm(0.30\%+10mA)$	$\leq \pm(0.30\%+10mA)$	$\leq \pm(0.30\%+10mA)$
DC LOAD CHARACTERISTIC				
Channel	2	2	2	1
Display Power	0-50.00W	0-50.00W	0-50.00W	0-100.00W
Display Voltage	1-33.00V	1-33.00V	1-33.00V	1-33.00V
Display Current	0-3.200A	0-3.200A	0-3.200A	0-6.200A
CV Mode Setting Range	1.500V-33.00V	1.500V-33.00V	1.500V-33.00V	1.500V-33.00V
Resolution	10mV	10mV	10mV	10mV
Set Accuracy	$\leq 0.1\%+30mV$	$\leq 0.1\%+30mV$	$\leq 0.1\%+30mV$	$\leq 0.1\%+30mV$
Read Accuracy	$\leq 0.1\%+30mV$	$\leq 0.1\%+30mV$	$\leq 0.1\%+30mV$	$\leq 0.1\%+30mV$
CC Mode Setting Range	0-3.200A	0-3.200A	0-3.200A	0-6.200A
Resolution	1mA	1mA	1mA	1mA
Set Accuracy	$\leq 0.3\%+10mA$	$\leq 0.3\%+10mA$	$\leq 0.3\%+10mA$	$\leq 0.3\%+10mA$
Read Accuracy	$\leq 0.3\%+10mA$	$\leq 0.3\%+10mA$	$\leq 0.3\%+10mA$	$\leq 0.3\%+10mA$
CR Mode Setting Range	1-1k Ω	1-1k Ω	1-1k Ω	1-1k Ω
Resolution	1 Ω	1 Ω	1 Ω	1 Ω
Set Accuracy	$\leq 0.3\%+1\Omega$	$\leq 0.3\%+1\Omega$	$\leq 0.3\%+1\Omega$	$\leq 0.3\%+1\Omega$
Read Accuracy	(Voltage $\geq 0.1V$, and current $\geq 0.1A$)	(Voltage $\geq 0.1V$, and current $\geq 0.1A$)	(Voltage $\geq 0.1V$, and current $\geq 0.1A$)	(Voltage $\geq 0.1V$, and current $\geq 0.1A$)
INSULATION				
Chassis and Terminal	20M Ω or above (DC 500V)	20M Ω or above (DC 500V)	20M Ω or above (DC 500V)	20M Ω or above (DC 500V)
Chassis and AC Cord	30M Ω or above (DC 500V)	30M Ω or above (DC 500V)	30M Ω or above (DC 500V)	30M Ω or above (DC 500V)
ENVIRONMENT CONDITION				
Operation Temp	0-40 $^{\circ}C$	0-40 $^{\circ}C$	0-40 $^{\circ}C$	0-40 $^{\circ}C$
Storage Temp	-10-70 $^{\circ}C$	-10-70 $^{\circ}C$	-10-70 $^{\circ}C$	-10-70 $^{\circ}C$
Operating Humidity	$\leq 80\%$ RH	$\leq 80\%$ RH	$\leq 80\%$ RH	$\leq 80\%$ RH
Storage Humidity	$\leq 70\%$ RH	$\leq 70\%$ RH	$\leq 70\%$ RH	$\leq 70\%$ RH
EXTERNAL CONTROL				
Yes	Yes	Yes	Yes	Yes
INTERFACE				
Std:	RS-232/USB(CDC), Opt(Manufacturer installed only): LAN/ GPIB+LAN	RS-232/USB(CDC), Opt(Manufacturer installed only): LAN/ GPIB+LAN	RS-232/USB(CDC), Opt(Manufacturer installed only): LAN/ GPIB+LAN	RS-232/USB(CDC), Opt(Manufacturer installed only): LAN/ GPIB+LAN
POWER SOURCE				
AC	100V/120V/220V/230V $\pm 10\%$, 50/60Hz	100V/120V/220V/230V $\pm 10\%$, 50/60Hz	100V/120V/220V/230V $\pm 10\%$, 50/60Hz	100V/120V/220V/230V $\pm 10\%$, 50/60Hz
DIMENSION & WEIGHT				
	213(W) x 145(H) x 312(D) mm ; Approx. 7.5kg	213(W) x 145(H) x 312(D) mm ; Approx. 7.5kg	213(W) x 145(H) x 312(D) mm ; Approx. 7.5kg	213(W) x 145(H) x 312(D) mm ; Approx. 7.5kg

OPERATING RANGE

Model Number	Number of Outputs	CH1	CH2	CH3	CH4
GPP-1326	1	0-32V/0-6A			
GPP-2323	2	0-32V/0-3A	0-32V/0-3A		
GPP-3323	3	0-32V/0-3A	0-32V/0-3A	1.8V/2.5V/3.3V/5V/5A	
GPP-4323	4	0-32V/0-3A	0-32V/0-3A	0-5V/0-1A	0-15V/0-1A

OUTPUT FUNCTION LIST

Model Number	GPP-4323			
	GPP-3323			
Number of Outputs	GPP-2323			
	GPP-1326			
	CH1	CH2	CH3	CH4
Sequence Output Function	✓	✓		
Load Functions (CC, CV, CR mode)	✓	✓		
Output Delay Function	✓	✓		
Output Monitoring Monitor(10 sets)	✓	✓	[GPP-4323 not supported]	✓
Output Recorder Function	✓	✓	[GPP-3323 not supported]	✓
Panel Save/Recall	✓	✓	✓	✓

ORDERING INFORMATION

- GPP-1326 (32V/6A) Single-Output Programmable DC Power Supply
 - GPP-2323 (32V/3A*2) Dual-Output Programmable DC Power Supply
 - GPP-3323 (32V/3A*2; 1.8V or 2.5V or 3.3V or 5V/5A*1) Three-Output Programmable DC Power Supply
 - GPP-4323 (32V/3A*2; 5V/1A; 15V/1A) Four-Output Programmable DC Power Supply
- ACCESSORIES :
- User Manual x 1, Power cord x 1
 - GPP-1326 Test Lead GTL-104A x 1, GTL-105A x 1
 - GPP-4323 Test Lead GTL-104A x 2, GTL-105A x 2
 - GPP-2323 Test Lead GTL-104A x 2
 - GPP-3323 Test Lead GTL-104A x 3
- European Test Leads :
- GPP-1326 GTL-203A x 1, GTL-204A x 1, GTL-201A x 1
 - GPP-4323 GTL-203A x 2, GTL-204A x 2, GTL-201A x 1
 - GPP-2323 GTL-204A x 2, GTL-201A x 1
 - GPP-3323 GTL-204A x 3, GTL-201A x 1

OPTIONAL ACCESSORIES

GTL-246 USB Cable

OPTIONS (Manufacturer Installed Only)

LAN Interface; GPIB+LAN Interface

A. TRACKING SERIES AND PARALLEL FUNCTION

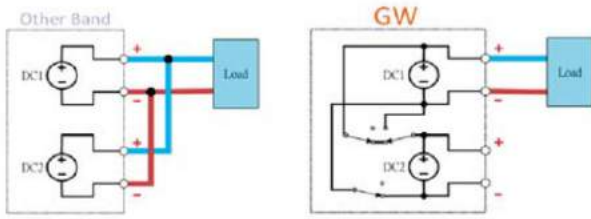

Output in Parallel Connections

For series and parallel applications of CH1 and CH2, the tracking function of the GPP-Series utilizes the internal circuit to automatically switch the output to serial or parallel output without additional external wiring, providing users with convenience not only in operating procedures but also a more stable output.

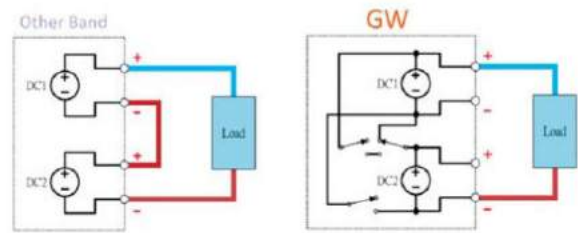

Output in Series Connections

The tracking function design of other brands requires additional external wiring connections for the output in series or parallel. However, excessively long, thin or inconsistent external wiring may cause inaccurate voltage or current output.

B. OUTPUT MONITORING FUNCTION

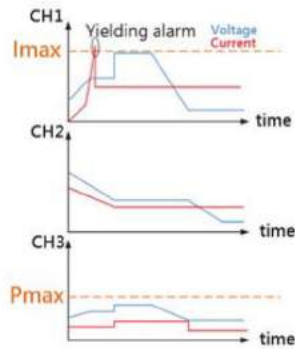

Output Monitoring

The output monitoring function allows users to set the monitoring conditions according to the requirements, including the voltage, current, and power greater than or less than the setting and the logical relationship of AND, OR. It also allows users to sound



Monitoring Function Setting

alarms or stop the output during the measurement process, stop the measurement, and protect the customer's DUT. Each Channel could be monitored simultaneously as well.

* Channel 3 of GPP-3323 does not support the output monitoring function.

C. SEQUENCE OUTPUT FUNCTION



Output Waveform of the GPP-X323 Series

The GPP-Series provides a sequential output function on Channel 1 and Channel 2. This function not only allows users to edit the power output waveform, but also allows users to set the sequential constant voltage (CV) or constant current (CC) load waveform, i.e. a serial power output or a simulation test of a dynamic load. The maximum settable points for sequence function are 2048, and interval range of each point can be set from 1 to 300 seconds. In order to simplify the setting of waveform editing, the GPP-Series has 8 built-in Templet waveforms in sequence output function for

users to directly apply for output, including Sine, Pulse, Ramp, Stair Up, Stair Dn, Stair UpDn, Exp Rise, and Exp Fall waveforms.

The editing data of the sequence output can be stored in the internal 10 sets of the memory, or to be saved by USB flash drive (Save/Recall) and saved as *.SEQ or *.CSV file; The stored *.CSV can be exported into Excel for editing and analysis. The final edited file can be imported to (Save/Recall) of the power supply using a USB flash drive.

Multi-output Programmable D.C. Power Supply

D. HARDWARE PROTECTION FUNCTION(OVP/OCP/OTP)

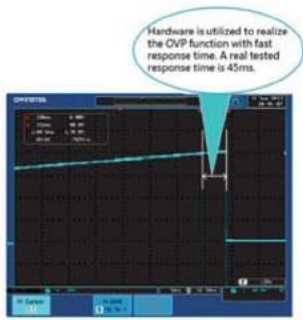

OVP Trigger

The protection mechanism of OVP/OCP/OTP is implemented by hardware circuit, which has the advantage of faster response time than competitors who use software to achieve protection. When it is detected that the voltage of the DUT exceeds the setting value of the OVP, the output of the power supply can be stopped in a short time to achieve the purpose of protecting the DUT.

E. LOAD FUNCTION

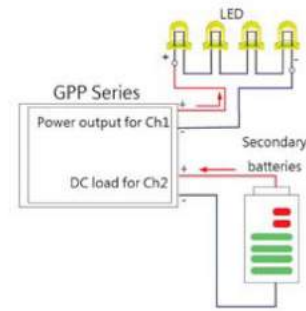

GPP-Series Application

The CH1/CH2 of the GPP-Series is designed with the load function. A single power supply can meet the basic battery charging and discharging test requirements. It can provide 32V/3A power output in channel 1 and channel 2. The maximum 32V constant voltage load (CV), maximum 3.2A constant current load (CC) and maximum 1kΩ constant resistance load (CR) function are built-in to allow users do conduct discharging test without using an electronic load. In application, users can also set either that one channel of the single GPP series as the power output, one channel as the load function to consume the power of the DUT, or that both channels as load functions to consume the power of different loads simultaneously.

F. OUTPUT DELAY FUNCTION



GPP-Series Delayed Waveform

Output delay function allows users to edit the timing waveform of the power output on/off when the front panel voltage and current settings are unchanged. In order to simplify the setting of waveform editing, the GPP-Series has three built-in timing modes in the delay output function, including Fixtime, Increase, Decline for users to apply directly. The editing data of the output delay can be stored in

the internal 10 sets of memory, or to be saved by USB flash drive (Save/Recall) and saved as *.DLY or *.CSV file. The stored *.CSV can be exported into Excel for editing and analysis. The final edited file can be exported to (Save/Recall) of the power supply using a USB flash drive.

G. OUTPUT RECORDER FUNCTION

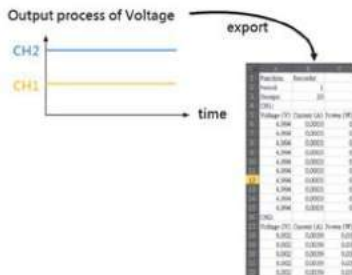

Schematic Diagram for Recorder Function

The output recorder function records the voltage & current parameters of the output process. The recording interval of each point can be set according to user's requirements, and the shortest interval is 1 second and the longest is 300 seconds. The results can be stored in *.REC or *.CSV format to the power supply or directly



Recorder Function Setting



Save as *.REC

saved in the USB flash drive. The stored *.CSV can be exported into Excel to conduct the future analysis. (*.REC can be saved to 2018 records, *.CSV can be saved to 614400 records)

* Channel 3 of GPP-3323 does not support the output recorder function

Multiple Output Dual Range D.C. Power Supply



SPD-3606



FEATURES

- * Three Independent, Isolated Output
- * CH1/CH2 : Dual Output Range of 30V/6A or 60V/3A
- * CH3 Adjustable Output : 0.1~5V/3A
- * High Efficiency Power Conversion (Up to 25% Than Traditional Power Supply)
- * Remote Output On/Off Control
- * OVP to Protect the DUT
- * OTP to Protect SPD-3606 for Reducing the Repair Rate
- * Automatically Switches AC 115V/230V Source
- * Full Safety Design: Reverse Polarity, CH3 Overload Protection, Safe Output Setting , C.C./C.V. Mode
- * Compact Size, Light Weight
- * Low Fan Acoustic Noise with Fan Speed Control Circuit
- * Voltage/Current Protection Knob(Optional)
- * Optional European Jack Type Terminal

European Type Jack Terminal



Rear Panel



GPS-001

Voltage/Current protection Knob



The SPD-3606 DC power supply provides 375W output capacity, three isolated outputs with dual-range for CH1 & CH2, highly efficient power conversion, low noise, high reliability, thorough protection, excellent value and a compact size. SPD-3606 creates a new bench mark for satisfying mainstream power supply demands. CH1 & CH2 offer dual-range output either at 30V/6A or 60V/3A per channel to accommodate a wide range of applications. SPD-3606 supports series and parallel tracking, allowing the CH1 and CH2 to be internally connected in series or parallel providing flexible output (30V/12A, 60V/6A, or 120V/3A). High power density and high power conversion efficiency lets SPD-3606 consume less energy making for a greener power supply. In addition, the high power density makes SPD-3606 weigh less than half and occupy much less space compared to linear power supplies. To avoid damage caused by improper operation, it also has OVP and OTP. The dual range AC input accepts both 115V and 230V inputs. When the instrument is on, devices can be connected and voltage/current levels can be adjusted safely from the front panel by turning off the output using the Output on/off key. The optional voltage/current protection knobs can be used to prevent accidentally changing the output levels. These knobs are useful for automated testing at fixed output levels, such as in assembly lines or product inspections.

SPECIFICATIONS

OUTPUT RATINGS

CH1/CH2 Independent	0 ~ 30V / 0 ~ 6A ; 0 ~ 60V / 0 ~ 3A
CH1/CH2 Series	0 ~ 60V / 0 ~ 6A ; 0 ~ 120V / 0 ~ 3A
CH1/CH2 Parallel	0 ~ 30V / 0 ~ 12A ; 0 ~ 60V / 0 ~ 6A
CH3	0.1 ~ 5V / 3A

VOLTAGE REGULATION

Line	≤ 0.01% + 3mV
Load	≤ 0.01% + 5mV (rating current ≤ 6A) ≤ 0.01% + 8mV (rating current ≤ 12A)
Ripple & Noise	≤ 5mVrms (5Hz ~ 1MHz) ; ≤ 50mVpp (20Hz ~ 20MHz)
Recovery Time	≤ 100 μs (50% load change, minimum load 0.5A)

CURRENT REGULATION

Line	≤ 0.2% + 3mA
Load	≤ 0.2% + 3mA
Ripple & Noise	≤ 3mArms

TRACKING OPERATION

Tracking Error	≤ 0.5% + 10mV of master
Series Regulation	≤ 300mV
Ripple & Noise	≤ 10mVrms (5Hz ~ 1MHz) ; ≤ 100mVpp (20Hz ~ 20MHz)

OUTPUT ON/OFF RESPONSE TIME

Voltage Up (10% ~ 90%)	≤ 100ms (≤ 95% rating load)
Voltage Down (90% ~ 10%)	≤ 100ms (≥ 10% rating load)

OVP

Accuracy	± (0.5% of reading + 0.5V)
----------	----------------------------

METER

Type	3 1/2 digit 0.5" LED display
Accuracy	± (0.5% of reading + 2 digits)
Resolution	100mV/10mA

INSULATION

Chassis & Terminal	100MΩ or above (DC 1000V)
Chassis & AC code	100MΩ or above (DC 1000V)

TEMPERATURE COEFFICIENT

Voltage	≤ 100ppm/°C + 3mV
Current	≤ 150ppm/°C + 3mA

REMOTE CONTROL

Output On/Off

FAN NOISE

≤ 50dB

OPERATION ENVIRONMENT

Ambient temperature 0 ~ 40 °C ; Relative humidity ≤ 80%

STORAGE ENVIRONMENT

Ambient temperature -10 ~ 70 °C ; Relative humidity ≤ 70%

POWER SOURCE

AC 115V/230V ± 15%, 50/60Hz

DIMENSIONS & WEIGHT

255 (W) x 145 (H) x 265 (D) mm ; Approx. 6kg

ORDERING INFORMATION

SPD-3606 Multiple Output Dual Range D.C. Power Supply

ACCESSORIES :

User manual x 1, Power code x 1, Test lead GTL-104A x 2, GTL-105A x 1
European Test Lead GTL-201A x 1, GTL-203A x 1, GTL-204A x 2

OPTIONAL ACCESSORIES

GPS-001 Voltage/Current protection Knob

Multiple Output Linear D.C. Power Supply



GPE-X323 Series



FEATURES

- * 1/2/3/4 Independent Isolated Output
- * 4.3 Inch LCD Display
- * Setting & Read Back Resolution 100mV/10mA (*1)
- * Output ON/OFF Switch
- * Analog Control (Remote I/O) For Output ON/OFF
- * Set View Function For Checking an Original V/I Setting During Output On
- * Key Lock Function
- * Tracking Series And Parallel Operation
- * Smart Cooling Fan Achieving Low Noise
- * Optional European Jack Type Terminal

The GPE-X323 series is cutting edge, economical linear DC Power supplies. The GPE-X323 series features output power from 192 to 217 watts, three independent isolated output channels (for GPE-3323), high resolution, low noise, high reliability, and compact size.

The GPE-X323 series has a built-in digital panel control design to replace conventional control method. This unique design allows the GPE-X323 series linear DC power supply to provide users with more efficient functionalities, including set view and key lock so as to expedite the operation process. The key lock function protects DUTs by preventing others from changing voltage and current parameters. Additionally, output key light facilitates users in clearly reading the operational status of power supply.

SPECIFICATIONS

	GPE-4323				GPE-3323			GPE-2323		GPE-1326
OUTPUT MODE										
Number of Channel	CH1	CH2	CH3	CH4	CH1	CH2	CH3	CH1	CH2	CH1
Voltage	0~32V	0~32V	0~5V	0~15V	0~32V	0~32V	5V	0~32V	0~32V	0~32V
Current	0~3A	0~3A	0~1A	0~1A	0~3A	0~3A	5A	0~3A	0~3A	0~6A
Tracking Series Voltage	0~64V				0~64V			0~64V		-
Tracking Parallel Current	0~6A				0~6A			0~6A		-
CONSTANT VOLTAGE OPERATION										
Line Regulation	≤ 0.01%+3mV									
Load Regulation	≤ 0.01%+3mV (rating current ≤ 3A) ≤ 0.02%+5mV (rating current > 3A)									
Ripple & Noise	≤ 1mVrms (5Hz~1MHz)									
Recovery Time	≤ 100μs (50% Load Change, minimum load 0.5A)									
CONSTANT CURRENT OPERATION										
Line Regulation	≤ 0.2%+3mA									
Load Regulation	≤ 0.2%+3mA									
Ripple & Noise	≤ 3mArms									
TRACKING OPERATION (CH1,CH2)										
Tracking Error	≤ 0.1%+10mV of Master(0~32V) No Load , with Load add load regulation ≤ 100mV									
Parallel Regulation	Line : ≤ 0.01%+3mV Load : ≤ 0.01%+3mV (rating current ≤ 3A) ≤ 0.02%+5mV (rating current > 3A)									
Series Regulation	Line : ≤ 0.01%+5mV Load : ≤ 100mV									
Ripple & Noise	≤ 2mVrms , 5Hz ~ 1MHz									
CH3 OPERATION FOR (GPE-3323)										
Output Voltage	5.0V, ±5%									
Output Current	5A									
Line Regulation	≤ 3mV									
Load Regulation	≤ 5mV									
Ripple & Noise	1mVrms (5Hz~1MHz)									
METER										
Voltage Resolution	100mV (*1)									
Current Resolution	10mA (*1)									
Setting Accuracy	Voltage±(0.1% of reading +30mV); Current±(0.3% of reading +6mA)									
Readback Accuracy	Voltage±(0.1% of reading +30mV); Current±(0.3% of reading +6mA)									
INSULATION										
Chassis and Terminal	20MΩ or above (DC 500V)									
Chassis and AC Cord	30MΩ or above (DC 500V)									
ENVIRONMENT CONDITION										
Operation Temp	0~40°C									
Storage Temp	-10~70°C									
Operating Humidity	≤ 80% RH									
Storage Humidity	≤ 70% RH									
OTHER										
Power Source	AC100V/120V/220V±10%; 230V (+10%~-6%); 50/60Hz									
Dimensions & Weight	210(W)× 155(H) × 306(D) mm ; Approx. 7kg									



GPE-X323 Series

Rear Panel



European Type Jack Terminal



ORDERING INFORMATION

- GPE-1326** Single Channel, 192W Linear DC Power Supply
- GPE-2323** 2 Channels, 192W Linear DC Power Supply
- GPE-3323** 3 Channels, 217W Linear DC Power Supply
- GPE-4323** 4 Channels, 212W Linear DC Power Supply

ACCESSORIES :

User Manual (CD) x 1 ; Power Cord x 1

- GPE-1326** Test Lead GTL-104A x 1 ; GTL-105A x 1 ; or European GTL-204A x 1, GTL-203A x 1
- GPE-2323** Test Lead GTL-104A x 2 ; or European GTL-204A x 2
- GPE-3323** Test Lead GTL-104A x 3 ; or European GTL-204A x 3
- GPE-4323** Test Lead GTL-104A x 2 ; GTL-105A x 2 or European GTL-204A x 2 , GTL-203A x 2

Note : (*1) For a higher resolution (10mV/1mA), please follow the setting procedure of the user manual on p35.
When using a higher resolution, the current or voltage adjustment may be limited by the knob sensibility.

A. TRACKING SERIES AND PARALLEL OPERATION

In addition to independent output channels, the GPE-X323 series provides tracking series and parallel operation (For GPE-2323/GPE-3323/GPE-4323). The series and parallel connections allow power supplies to output 32V/6A (Parallel Connection) and 64V/3A (Series Connection).



Internal connection for tracking Series and Parallel operation via control panel

B. CONVENIENT FUNCTION

The GPE-X323 series has a built-in set view and key lock so as to expedite the operation process. The key lock function protects DUTs by preventing others from changing voltage/current parameters.



The key lock function prevent DUTs from unnecessary damages caused by mis-operation.

C. REMOTE I/O FOR OUTPUT ON/OFF FUNCTION

The GPE-X323 Series also provides the analog control (Remote I/O) function for external output On/Off control.



For controlling the output On/Off function through the specific pin assignment of remote control connector which is in rear panel.

Multiple Output Linear D.C. Power Supply



GPS-2303/3303/4303



FEATURES

- * 2, 3 and 4 Independent Isolated Output
- * Four "3 Digits" LED Displays
- * 0.01% Load and Line Regulation
- * Low Ripple and Noise
- * Tracking Operation and Auto Series/Parallel Operation
- * Output ON/OFF Switch
- * Output Voltage and Current Setting When Output Disable (Except for GPS-2303)
- * Fan Speed Control Circuit to Minimize Fan Noise
- * Over Load and Reverse Polarity Protection
- * Optional European Jack Type Terminal

European Type Jack Terminal



GPS-001

Voltage/Current protection Knob



Rear Panel



GPS-3303

The GPS Series linear power supplies have 2-4 independent output channels, 180W to 200W output, overload and reverse polarity protection as well as an output ON/OFF switch for safety. The tracking mode switches allow voltage/current to be output in parallel or series and the intelligent fan reduces noise. The GPS-Series is entry level general purpose power supplies recognized for their affordability in education, laboratories and industry.

SPECIFICATIONS									
	GPS-4303				GPS-3303			GPS-2303	
OUTPUT MODE									
	CH1	CH2	CH3	CH4	CH1	CH2	CH3	CH1	CH2
Voltage	0 ~ 30V	2.2 ~ 5.2V	8 ~ 15V		0 ~ 30V	5V Fixed		0 ~ 30V	
Current	0 ~ 3A	1A Max.	1A Max.		0 ~ 3A	3A Max.		0 ~ 3A	
Tracking Series Voltage	0 ~ 60V				0 ~ 60V			0 ~ 60V	
Tracking Parallel Current	0 ~ 6A				0 ~ 6A			0 ~ 6A	
CONSTANT VOLTAGE OPERATION (CH1, CH2)									
Line Regulation	≤ 0.01% + 3mV								
Load Regulation	≤ 0.01% + 3mV (rating current ≤ 3A) ≤ 0.02% + 5mV (rating current > 3A)								
Ripple & Noise	≤ 1mVrms, 5Hz ~ 1MHz								
Recovery Time	≤ 100μs (50% Load change, Minimum load 0.5A)								
CONSTANT CURRENT OPERATION (CH1, CH2)									
Line Regulation	≤ 0.2% + 3mA								
Load Regulation	≤ 0.2% + 3mA								
Ripple & Noise	≤ 3mArms								
TRACKING OPERATION (CH1, CH2)									
Tracking Error	≤ 0.5% + 10mV of CH1								
Series Regulation	≤ 0.01% + 5mV								
Load Regulation	≤ 300mV								
Ripple & Noise	≤ 2mVrms, 5Hz ~ 1MHz								
CH3 OPERATION (for GPS-3303/4303)									
CH3 Voltage	GPS-4303 : 2.2V ~ 5.2V, GPS-3303 : 5V Fix								
Line Regulation	≤ 5mV								
Load Regulation	≤ 15mV								
Ripple & Noise	≤ 2mVrms, 5Hz ~ 1MHz								
Current Output	GPS-4303 : 1A, GPS-3303 : 3A								
CH4 OPERATION (for GPS-4303)									
CH4 VOLTAGE	8V ~ 15V								
Line Regulation	≤ 5mV								
Load Regulation	≤ 10mV								
Ripple & Noise	≤ 2mVrms, 5Hz ~ 1MHz								
Current Output	1A								
METER									
Digital	3 digits 0.5" LED display GPS-4303/3303 Out ON Accuracy ± (0.5% of rdg + 2 digits) GPS-4303/3303 Out OFF Accuracy ± (0.5% of rdg + 8 digits) GPS-2303 Accuracy ± (0.5% of rdg + 2 digits)								
INSULATION									
Chassis and Terminal	≥ DC 500V / 20MΩ								
Chassis and AC Cord	≥ DC 500V / 30MΩ								
POWER SOURCE									
AC 100V/120V/220V±10%, 230V(+10%~-6%), 50/60Hz									
DIMENSIONS & WEIGHT									
255(W) x 145(H) x 265(D) mm, Approx. 7 kg									

ORDERING INFORMATION

- GPS-4303 4-channels, 200W Multiple Output Linear DC Power Supply
- GPS-3303 3-channels, 195W Multiple Output Linear DC Power Supply
- GPS-2303 2-channels, 180W Multiple Output Linear DC Power Supply

ACCESSORIES :

- User manual x 1, Power cord x 1,
- GPS-4303 : Test lead GTL-104A x 2, GTL-105A x 2 ; European test lead GTL-203A x 2, GTL-204A x 2, GTL-201 x 1
- GPS-3303 : Test lead GTL-104A x 2, GTL-105A x 1 ; European test lead GTL-203A x 1, GTL-204A x 2, GTL-201 x 1
- GPS-2303 : Test lead GTL-104A x 2 ; European test lead GTL-204A x 2, GTL-201A x 1

OPTIONAL ACCESSORIES

- GPS-001 Voltage/Current Protection Knob

Triple Output Linear D.C. Power Supply



GPC-1850D/3030D/3060D/6030D



(Note: GPC-3060D/6030D are not CE approved.)



GPC-3030DQ



FEATURES

- * Four Digital Panel Meters (GPC-3030DQ)
- * Triple Output
- * Auto Tracking
- * Auto Series and Parallel Operation
- * Constant Voltage and Constant Current Operation
- * Low Ripple and Noise
- * Internal Select for Continuous or Dynamic Load
- * Overload and Reverse Polarity Protection
- * 3 1/2 Digits 0.39" LED Display(GPC-3030DQ)
- * 3 1/2 Digits 0.5" LED Display(GPC-1850D/3030D/3060D/6030D)
- * 5V, 3A Fixed Output

The GPC-Series is triple output, 195W to 375W, linear DC power supplies. Channel 1 and 2 are fully adjustable (model dependant) and channel 3 is fixed at 5V/3A with ripple and noise at less than 2mVrms. Overload and reverse polarity protection keep GPC-Series and its loads safe from unexpected conditions. GPC-3030DQ contains a temperature controlled cooling fan for thermal protection. GPC features continuous or dynamic internal load selection and series or parallel tracking for application flexibility. The GPC-Series is an ideal solution for inexpensive bench-top applications requiring low noise and multiple outputs.

SPECIFICATIONS	
OPERATION MODE	
Independent	Two independent outputs and 5V fixed output
Series	Output from 0 to rating volts and 0 to rating amperes
Parallel	Output from 0 to \pm rating volts at rating amperes each Output from 0 to double rating volts at rating amperes
CONSTANT VOLTAGE OPERATION	
Regulation	Line regulation $\leq 0.01\% + 3mV$ Load regulation $\leq 0.01\% + 3mV$ (rating current $\leq 3A$) $\leq 0.01\% + 5mV$ (rating current $\leq 10A$) $\leq 0.02\% + 5mV$ (rating current $\geq 10A$)
Ripple & Noise	$\leq 1mVrms$ 5Hz ~ 1MHz
Recovery Time	$\leq 100\mu S$ (50% Load change, Minimum load 0.5A)
CONSTANT CURRENT OPERATION	
Regulation	Line regulation $\leq 0.2\% + 3mA$ Load regulation $\leq 0.2\% + 3mA$ (for GPC-1850D/GPC-3030D/GPC-3030DQ) Load regulation $\leq 0.2\% + 5mA$ (for GPC-3060D/GPC-6030D)
Ripple Current	$\leq 3mA_{rms}$
5V FIXED OUTPUT	
Regulation	Line regulation $\leq 5mV$ Load regulation $\leq 10mV$
Ripple & Noise	$\leq 2mVrms$
Voltage Accuracy	$5V \pm 0.25V$
Output Current	3A
TRACKING OPERATION	
Tracking Error	$\leq 0.5\% + 10mV$ of the master
Series Regulation	$\leq 300mV$
METER	
Digital	3 1/2 digits 0.5" LED display 3 1/2 digits 0.39" LED display (for GPC-3030DQ) Accuracy $\pm (0.5\% \text{ of rdg} + 2 \text{ digits})$
INSULATION	
Chassis and Terminal	20M Ω or above (DC 500V) 100M Ω or above (DC 1000V) (for GPC-3060D/6030D)
Chassis and AC Cord	30M Ω or above (DC 500V) 100M Ω or above (DC 1000V) (for GPC-3060D/6030D)
POWER SOURCE	
AC 100V/120V/220V/240V $\pm 10\%$, 50/60Hz	
DIMENSIONS	
255(W) x 145(H) x 420(D) mm	

ORDERING INFORMATION

Model	Independent	Series	Parallel	Weight (kg)
GPC-1850D	195W D.C. Power Supply (0 ~ 18V/0 ~ 5A) x 2, (5V/3A MAX) x 1	36V 5A	18V 10A	11.5
GPC-3030D	195W D.C. Power Supply (0 ~ 30V/0 ~ 3A) x 2, (5V/3A MAX) x 1	60V 3A	30V 6A	11.5
GPC-6030D	375W D.C. Power Supply (0 ~ 60V/0 ~ 3A) x 2, (5V/3A MAX) x 1	120V 3A	60V 6A	18.5
GPC-3060D	375W D.C. Power Supply (0 ~ 30V/0 ~ 6A) x 2, (5V/3A MAX) x 1	60V 6A	30V 12A	18.5
GPC-3030DQ	195W D.C. Power Supply (0 ~ 30V/0 ~ 3A) x 2, (5V/3A MAX) x 1	60V 3A	30V 6A	11.5

ACCESSORIES :

User manual x 1, Power cord x 1
Test lead GTL-105A x 1 ($\leq 3A$) or GTL-104A x 2 ($\leq 10A$)

OPTIONAL ACCESSORIES

GRA-401 Rack Mount Kit



AC POWER SOURCES

GW Instek AC Power Sources currently can be divided into three categories.

AC Power Source APS-1102A not only plays the role as a precision AC/DC power source but also a powerful analyzer. It contains abundant features for the testing and characteristic analysis of power supplies, electronic devices, components and modules.

The APS-7000 series is programmable linear AC Power Source, with the height of 2U and output frequency range is 45~500Hz. The maximum rated output for APS-7050 is 500VA, 310Vrms, 4.2Arms and APS-7100 is 1000VA, 310Vrms, 8.4Arms. The APS-7000 series comprises nine measurement and test functions and provides user interface similar to that of AC Power Meter.

PRODUCTS

- Programmable AC/DC Power Source
- Programmable AC Power Source
- AC Power Source

AC POWER SOURCES

Programmable Switching AC/DC Power Source

GW Instek not only provides compact and lightweight switching AC/DC power sources but also features AC and AC+DC power outputs and the real time measurements of voltage, current, power, frequency, PF, and harmonic current. Four signal sources are collocated as Internal (INT), External (EXT), Internal+ External (ADD), and External Synchronization (SYNC) to flexibly output power so as to meet customers' demands. The powerful sequence function is very suitable for producing arbitrary waveforms. 16 sets of arbitrary waveform storage space and 30 sets of panel setting memory space are provided for data storage and setting input.

Linear AC Power Source

GW Instek recommends linear AC power source for AC power with the requirements of high accuracy, high stability and low ripple/noise. Programmable AC Power Source APS-7000 is suitable for simulating AC power outputs and it has 9 measurement functions (Vrms, Irms, F, Ipk, W, VA, PF, Ipk hold, CF), 7 waveform modes, Sequence mode, Simulate mode, and Surge/Dip Control Mode etc. Purpose AC power source applications, non-programmable AC source APS-7000E Series, with high precision and THD of less than 0.5%, is the ideal selection.

PROGRAMMABLE SWITCHING AC/DC POWER SOURCE

Model	Output Capacity	Output Freq.	Output Voltage	Max. Current	Display Type	Weight(kg)	Page
APS-1102A	1k VA	1~550Hz	AC 100V Range 0.0V~155.0V AC 200V Range 0.0V~310.0V DC 100V Range -220.0V~+220.0V DC 200V Range -440.0V~+440.0V	AC 100V Range 10A AC 200V Range 5A DC 100V Range 10A DC 200V Range 5A	LCD	9.7	D59-60

PROGRAMMABLE LINEAR AC POWER SOURCE

Model	Output Capacity	Output Freq.	Output Voltage	Max. Current	Display Type	Weight(kg)	Page
APS-7050	500 VA	45~500Hz Option: 45~999.9Hz	0~310V 0~155V Option: 0~600V	2.1A 4.2A	LCD	24	D61-64
APS-7100	1000 VA	45~500Hz Option: 45~999.9Hz	0~310V 0~155V Option: 0~600V	4.2A 8.4A	LCD	38	
APS-7200	2000 VA	45~500Hz Option: 45~999.9Hz	0~310V 0~155V Option: 0~600V	8.4A 16.8A	LCD	90	
APS-7300	3000 VA	45~500Hz Option: 45~999.9Hz	0~310V 0~155V Option: 0~600V	12.6A 25.2A	LCD	128	

LINEAR AC POWER SOURCE

Model	Output Capacity	Output Freq.	Output Voltage	Max. Current	Display Type	Weight(kg)	Page
APS-7050E	500 VA	45~500Hz	0~310V 0~155V	2.1A 4.2A	LCD	24	D65-66
APS-7100E	1K VA	45~500Hz	0~310V 0~155V	4.2A 8.4A	LCD	38	

Programmable AC/DC Power Supply



APS-1102A



FEATURES

- * 5.7" Large LCD Display
- * Output Capacity : 750VA (for AC 100V Input)/1kVA (for AC 200V Input)
- * Output Modes : AC and AC+DC Combined
With any of the Four Signal Sources
- * Signal Sources : Internal (INT), External (EXT), Internal + External(ADD) and Synchronisation (SYNC)
- * Arbitrary Waveform Power Output
- * Power Amplifier of External Signal
- * Measurement Functions : Voltage, Current, Power, Frequency, Power Factor, CF, and Harmonic Current
- * Capacitor Input Load Supported
- * Sequence Function Allows Programming of Output Patterns
- * Limiter Function (Upper/Lower Limits Function)
- * 30 Sets of SAVE/RECALL Memory
- * Output On/Off Switch
- * USB (USBTMC) and RS-232 Standard for Remote Control

APS-1102A is not only a precision AC/DC power supply, but also a powerful analyzer, containing abundant features for the testing and characteristic analysis of power supplies, electronic devices, components and modules. In addition to AC/DC power, APS-1102A is fully programmable to simulate different power outputs. Sequences can be created using arbitrary waveforms as well as voltage or frequency sweeps. Output is divided into two main operation modes: AC and AC+DC. Each mode can be combined with four signal source modes: internal (INT), external (EXT), internal + external (ADD) and external synchronization (SYNC) to provide flexible power settings. Voltage, current, power, frequency, load power factor, load crest factor and harmonic current output can be monitored in real-time. Even Inrush Current can easily be measured during the power-up of capacitive loads. All parameters and values as well as measurement results are displayed simultaneously on the 5.7 inch LCD screen. APS-1102A includes multi functional easy-to-use software that can be used with a USB or RS-232 interface. The software is used to remotely control panel settings, and to create and edit sequences and arbitrary waveforms. APS-1102A also has a universal power outlet on the front that is suitable for most countries as well as output terminal on the rear panel.

SPECIFICATIONS

MAXIMUM OUTPUT CAPACITY			
AC Input (100 ~ 180V)	750VA		
Input (180 ~ 250V)	1000VA		
DC Input (100 ~ 180V)	750W		
Input (180 ~ 250V)	1000W		
OUTPUT VOLTAGE			
AC 100V	0.0V ~ 155.0Vrms		
200V	0.0V ~ 310.0Vrms		
DC 100V	-220.0V~+220.0V		
200V	-440.0V~+440.0V		
OUTPUT MAX. CURRENT			
AC 100V	10A		
200V	5A		
DC 100V	10A		
200V	5A		
OUTPUT MAXIMUM PEAK CURRENTS			
100V	40Apk		
200V	20Apk		
FREQUENCY			
Setting Range	1.0Hz ~ 550.0Hz		
Setting Accuracy	±0.01% of set (1.0Hz~550.0Hz, 23±5°C)		
WAVEFORM			
SINE WAVE, SQUARE WAVE, ARBITRARY WAVE (Up To 16 Types Can Be Saved)	When signal source mode is INT and ADD mode only		
Output Voltage Distortion Rate	0.5% MAX(50Hz/60Hz), ±50% or higher of the rated output voltage, the maximum current or lower; THD+N		
LINE VOLTAGE REGULATION			
0.2% MAXIMUM	Power input voltage 100V/120V/230V, no load, rated output		
LOAD VOLTAGE REGULATION			
0.5% MAXIMUM	At output terminal under no load and rated resistance load		
MEASUREMENT			
	RANGE	RESOLUTION	ACCURACY
Frequency Counter	1.0 ~ 550.0 Hz	0.1Hz	0.01 % of set (1.0Hz~550.0Hz,23±5°C)
	At 45Hz~65Hz		
	Full Scale 100V:250.0Vrms	0.1Vrms	±(0.5 % of rdg+0.3Vrms); at 23±5°C
RMS Volt-Meter(AC+DC)	Full Scale 200V:500.0Vrms	0.1Vrms	±(0.5 % of rdg+0.6Vrms); at 23±5°C
	At DC 40Hz~550Hz		
	Full Scale 100V:250.0Vrms	0.1Vrms	±(0.7 % of rdg+0.9Vrms); at 23±5°C
RMS Amp-Meter(AC+DC)	Full Scale 200V:500.0Vrms	0.1Vrms	±(0.7 % of rdg+1.8Vrms); at 23±5°C
	At 45Hz~65Hz		
	Full Scale 15.00Arms	0.01Arms	±0.5% of rdg+0.04Arms ; at 23±5°C
Wattage Meter	At DC 40Hz~550Hz		
	Full Scale 15.00Arms	0.01Arms	±0.7% of rdg+0.08Arms ; at 23±5°C
	At 45Hz~65Hz		
	Full Scale 1200W	1W	±2% of rdg+1W ; at 23±5°C
	At DC		
	Full Scale 1200W	1W	±3% of rdg+12W ; at 23±5°C
			50V or higher output voltage, output current is 10% to 100% of the maximum current



APS-1102A

Rear Panel



SPECIFICATIONS			
	RANGE	RESOLUTION	ACCURACY
Load Power Factor Measurement	0.00 ~ 1.00	0.01	
Load Crest Factor Measurement	0.00 ~ 50.00	0.01	
External Synchronization Frequency Measurement	38.0Hz ~ 525.0Hz	0.1Hz	±0.2Hz; at 23±5°C
Phase When Output Is On	0.0° ~ 359.9°	0.1	When signal source mode is INT and ADD mode only
PROGRAM (SEQUENCE PROGRAMMING)			
Memory	1~30 Sets		
Step Range (Each Memory Set)	1~255 Step		
Step Time Setting	0.0001 S ~ 999.9999 S	0.0001S (=0.1mS)	
EXTERNAL SIGNAL INPUT (EXT Mode, ADD Mode)			
Gain Setting Range	100V range 0~220.0 times (Initial Value : 100.0)	0.1	± 5% (DC or 45Hz to 65Hz, gain is at initial value, with the rated voltage output, no load)
	200V range 0~440.0 times (Initial Value : 200.0)	0.1	± 5% (DC or 45Hz to 65Hz, gain is at initial value, with the rated voltage output, no load)
OUTPUT MODE			
AC - INT Mode	AC + DC - INT Mode	AC - ADD Mode	AC + DC - ADD Mode
AC - EXT Mode	AC + DC - EXT Mode	AC - SYNC Mode	AC + DC - SYNC Mode
MEMORY			
Save/Recall 30 sets			
POWER SOURCE			
AC100V ~ 230V ±10%; 50Hz / 60Hz ±2Hz (Signal Phase)			
POWER CONSUMPTION/FACTOR			
1.4kVA max / 0.95min (AC100V) ; 0.9min (AC200V)			
INTERFACE			
USB (USBTMC) & RS-232 Standard			
DIMENSIONS & WEIGHT			
258(W) X 176(H) X 440(D) ; Approx. 9.7 kg			

ORDERING INFORMATION

APS-1102A 1kVA Programmable AC/DC Power Source

ACCESSORIES :

User Manual x 1, Power Cord x 2. (15A/125V ; 2m ; for Japan)(10A/250V ; 1.5m without plug, for Japan, North America, and Europe only), CD-ROM (Remote Control Software) x 1

OPTIONAL ACCESSORIES

- GRA-409** Rack Mount Kit
- GTL-234** RS232 Cable
- GTL-246** USB Cable, USB 2.0, A-B Type, 1200mm

FREE DOWNLOAD

Remote Control Software
LabView Driver

GTL-234 RS-232C Cable

For: APS-1102A, LCR-8000G



500/1000/2000/3000 VA Programmable Linear AC Power Source



APS-7050



APS-7100

NEW



FEATURES

- * 4.3-inch TFT-LCD
- * Output Capacity: APS-7050(500VA,310Vrms,4.2Arms); APS-7100(1000VA,310Vrms,8.4Arms); APS-7200(2000VA,310Vrms,16.8Arms); APS-7300(3000VA,310Vrms,25.2Arms)
- * Output Augmentation by Options(0-600Vrms/45-999.9Hz)
- * Low Ripple & Noise
- * Measurement and Test Functions Include VOLT, CURR, PWR, SVA, IPKH, IPKH, FREQ, PF, CF
- * Support a Small AC Current Measurement 2mA -35A, Min. Resolution 0.01mA(APS-7050&APS-7100)
- * Reverse Current Alarm Function
- * 10 sets of Sequence Function to Edit Output Waveforms/10 sets of Simulate Mode to Rapidly Simulate Transient Power Supply/10 sets of Program Mode to Define Measurement Sequence/10 sets of Panel Memory Function
- * Automatic Execution of Sequence, Simulate, Program mode and Output Function when the Power is on
- * Standard Interfaces: USB Host, USB Device, LAN
- * Optional Interfaces: GPIB(APS-001); RS-232/USB CDC(APS-002 for APS-7050&APS-7100 only) RS-232(APS-007 for APS-7200& APS-7300 only)

APS-001 GPIB Interface Card

For: APS-7000 Series



APS-002 RS-232/USB Interface Card

For: APS-7000 Series



Mains Terminal Cover Set

For: APS-7100/7100E Series



For: APS-7050/7050E Series



GWInstek introduces APS-7000 series programmable AC power sources, which consists of 500VA of APS-7050, 1000VA of APS-7100, 2000VA of APS-7200 and 3000VA of APS-7300. APS-7000 series features power characteristics from its linear structure design including low noise, low THD, and highly stabilized power output that are ideal for the product development and verification of input power with low noise requirement or stereo, video and audio device applications, etc. The maximum rated voltage is 0-310Vrms, 25.2Arms, 100.8A peak current and the output frequency range is 45-500.0Hz. Users can conveniently augment the output voltage from 0Vrms to 600Vrms and output frequency from 45Hz to 999.9Hz by purchasing options without sending equipment back to GW Instek.

One of the popular alternative energy solutions in the market is to utilize inverter to convert DC to AC and the converted AC is then sent to power grid or products require electricity. For instance, AC produced by PV inverter is sent to power grid or equipment requires electricity. While simulating power grid to verify inverter connecting with power grid, general AC power sources cannot withstand DUT's feedback energy, hence, additional power consumption resistors are needed to prevent AC power source from being damaged. On the contrary, APS-7000 series has the characteristic of absorbing reverse current so that additional power consumption resistors are not required. The input terminal of APS-7000 series is designed to isolate from the simulated AC power grid output terminal, therefore, users do not need an additional isolation device to protect DUT. APS-7000 series is suitable for simulating power grid and conducting inverter output characteristic tests, including synchronized phase and frequency. Reverse current and power detected by APS-7000 series will be displayed in red readings to facilitate user's test observation. APS-7000 series utilizes Simulate mode and Sequence mode to provide a single step or consecutive power changes; and to simulate power grid's Voltage Abnormality Test and Frequency Abnormality Test.

APS-7000 series comprises nine measurement and test functions (Vrms, Irms, F, Ipk, W, VA, PF, Ipk hold, CF), and provides user interface similar to that of AC Power Meter. APS-7000 series is ideal for the LED industry and standby mode power consumption test. Under the ARB mode, APS-7000 series provides waveforms in seven categories including Sine waveform, Triangle waveform, Staircase waveform(Square wave), Clipped Sinewave, Crest factor waveform, Surge waveform, and Fourier series and 20,000 waveform combinations so as to meet the requirements of simulating abnormal input power waveform test of various industries. Ten Preset settings allow users to store ten sets of data; Power ON Output setting allows Sequence, Simulate, and Program to automatically execute output after the equipment power is on.

To meet the test criteria of line voltage fluctuation often seen in consumer electronics, APS-7000 series features five methods to cope with special purpose or abnormal voltage, frequency, and phase; ten sets of the Simulate mode simulate power outage, voltage rise, and voltage fall; ten sets of the Sequence mode allow users to define parameters and produce sine wave by editing steps; ten sets of the Program mode can edit AC waveform output and define the ceiling and floor level of measurement items for different DUTs; Ramp Control allows users to set the variation speed for output voltage rise and fall; Surge/Dip Control simulates DUT's input power producing a Surge or Dip voltage overlapping with output voltage waveform at a specific time. For larger current output applications, voltage drop across the output cables should be avoided. APS-7200/7300 also provide the remote sense function, which senses DUT's voltage and sends the information back to APS-7200/7300 for program controlled voltage compensation. Therefore, APS-7200/7300 can avoid the voltage drop of the cable to affect output voltage.

Ethernet Port, on the rear panel, can be used for remote program control; Sync Output Socket provides external 10V sync output; Signal Output Connector provides monitor of Program execution results. APS-7000 series also provides users with Trigger In/Out and Output on/off remote control functions from J1 connector on the rear panel.

SPECIFICATIONS

Model	APS-7050	APS-7100	APS-7200	APS-7300
AC OUTPUT				
Power Rating	500VA	1000VA	2000VA	3000VA
Output Voltage	0 ~ 155Vrms, 0 ~ 310Vrms	0 ~ 155Vrms, 0 ~ 310Vrms	0 ~ 155Vrms, 0 ~ 310Vrms	0 ~ 155Vrms, 0 ~ 310Vrms
Output Frequency	45.00 ~ 500.0 Hz	45.00 ~ 500.0 Hz	45.00 ~ 500.0 Hz	45.00 ~ 500.0 Hz
Maximum Current(r.m.s) *1	4.2A	8.4A	16.8A	25.2A
Maximum Current(peak)	2.1A	4.2A	8.4A	12.6A
OPT. APS-003(rms)	16.8A	33.6A	67.2A	100.8A
OPT. APS-003(peak)	8.4A	16.8A	33.6A	50.4A
OPT. APS-003(rms)	0-600Vrms	1.05A	2.1A	4.2A
OPT. APS-003(peak)	0-600Vrms	4.2A	8.4A	16.8A
Total Harmonic Distortion (THD)*2	≤ 0.5% at 45 ~ 500Hz (Resistive Load)			
Crest Factor	≥ 4			
Line Regulation	0.1% (% of full scale)			
Load Regulation	0.5% (% of full scale)			
Response Time	<100us			
Reverse Current	30% of Maximum Output RMS Current (Continue); 100% of Maximum Output RMS Current (Within 3 minutes)			
SETTING				
Voltage	Range	0-155Vrms, 0-310Vrms, Auto		
	Resolution	0.01V at 0.00 ~ 99.99Vrms; 0.1V at 100.0 ~ 310.0Vrms		
	Accuracy	±(0.5% of setting+2 counts)		
Frequency	Range	45 ~ 500Hz		
	Resolution	0.01Hz at 45.00 ~ 99.99Hz; 0.1Hz at 100.0 ~ 500.0Hz		
	Accuracy	±0.02% of setting		
Power On/Off	Range	0 ~ 359°		
Phase Angle	Resolution	1°		
	Accuracy	±1°(45 ~ 65Hz)		
MEASUREMENT*3				
Voltage(RMS)	Range	0.20-38.75Vrms;38.76-77.50Vrms; 77.51-155.0Vrms;155.1-310.0Vrms		0.20-38.75Vrms;38.76-77.50Vrms; 77.51-155.0Vrms;155.1-310.0Vrms
	Resolution	0.01V at 0.00 ~ 99.99Vrms; 0.1V at 100.0 ~ 310.0Vrms		0.01V at 0.00 ~ 99.99Vrms; 0.1V at 100.0 ~ 310.0Vrms
Frequency	Accuracy*4	±(0.5% of reading+2 counts)		±(0.5% of reading+2 counts)
	Range	45 ~ 500Hz		45 ~ 500Hz
	Resolution	0.01Hz at 45Hz-99.99Hz; 0.1Hz at 100Hz-500.0Hz		0.01Hz at 45Hz-99.99Hz; 0.1Hz at 100Hz-500.0Hz
Current(RMS)	Accuracy	±0.1Hz		±0.1Hz
	Range	2.00 ~ 70.00mA;60.0 ~ 350.0mA; 0.300 ~ 3.500A;3.00 ~ 17.5A		0.200 ~ 3.500A;3.00-35.00A
	Resolution	0.01mA, 0.1mA, 0.001A, 0.01A		0.001A;0.01A
	Accuracy	±(0.6% of reading+5 counts),2.00-350.0mA; ±(0.5% of reading+5 counts),0.300-3.500A; ±(0.5% of reading+3 counts),3.000-17.50A		±(0.5% of reading+5 counts),0.200-3.500A ±(0.5% of reading+3 counts),3.00-35.00A



APS-7200



APS-7300

APS-7300 Rear Panel



APS-7200 Rear Panel



APS-7100 Rear Panel



APS-7050 Rear Panel



Note:

The Specifications are not suit for ARB mode.

*1. Maximum output current at working voltage 120Vrms, 240Vrms

*2. 45-500Hz, 10% or higher of the rated output voltage, the maximum current or lower

*3. All of measurement accuracy is at 23±5°C

*4. In the case of 15-155V, 30-310V, sine wave, no load

APS-7000E Series

Europe Type Output Outlet



SPECIFICATIONS					
Model		APS-7050	APS-7100	APS-7200	APS-7300
Current(Peak)	Range	0.0 ~ 70.0A		0.0 ~ 140.0A	
	Resolution	0.1A		0.1A	
	Accuracy	±(1% of reading+1 count)		± 1% of reading+1 counts)	
Power(W)	Resolution	0.01W, 0.1W, 1W		0.1W, 1W	
	Accuracy	±(0.6% of reading+5 counts),0.20-99.99W; ±(0.6% of reading+5 counts),100.0-999.9W; ±(0.6% of reading+2 counts),1000-9999W		±(0.6% of reading+5counts),0.2-999.9W; ±(0.6% of reading+2counts),1000-9999W	
	Resolution	0.01VA, 0.1VA, 1VA		0.1VA, 1VA	
Apparent(VA)	Resolution	±(1% of reading+7 counts),0.20-99.99VA; ±(1% of reading+7 counts),100.0-999.9VA; ±(1% of reading+5 counts),1000-9999VA		±(1% of reading+7 counts),0.2-999.9VA; ±(1% of reading+5 counts),1000-9999VA	
	Accuracy				
	Resolution	0.001		0.001	
Power Factor	Resolution	±(2% of reading + 2 counts)		±(2% of reading+2 counts)	
	Accuracy				
GENERAL					
Remote output signal		Pass, Fail, Test-in Process, Trigger in, Trigger out, OUT ON/OFF			
Sync output signal		Output Signal 10 V, BNC Type			
Number of Preset		10 (0-9 numeric keys)			
Protection		OCP, OPP, OTP and Alarm			
Trigger Out		Maximum low level output = 0.8V ; Minimum high level output = 2V ; Maximum source current = 8mA			
Trigger In		Maximum low level input voltage = 0.8V ; Minimum high level input voltage = 2.0V; Maximum sink current = 8mA			
SEQUENCE/SIMULATION FUNCTION					
Number of Memories		10 (0 ~ 9 Numeric keys)			
Number of Steps		255 max. (For 1 sequence)			
Step Time Setting Range		0.01 ~ 999.99S			
Operation Within Step Parameters		Constant, Keep, Linear Sweep			
Sequence Control		Output Range, Frequency, Waveform (sine wave only); On: Phase, Off Phase, Term Jump Count (0 ~ 255) jump-to, Branch 1, Branch 2, Trigger Output Start, Stop, Hold, Continue, Branch 1, Branch 2			
AC INPUT					
Phase		Single Phase	Single Phase	Single Phase	Single Phase
Input Voltage		115/230Vac±15%	115/230Vac±15%	230Vac±15%	230Vac±15%
Input Frequency		50/60Hz	50/60Hz	50/60Hz	50/60Hz
Max. Current		16A/8A	32A/16A	32A	50A
Power Factor		0.7 Typ.	0.7 Typ.	0.7 Typ.	0.7 Typ.
ENVIRONMENT CONDITIONS					
Operating Temperature Range		0 ~ +40°C			
Storage Temperature Range		-10 ~ +70°C			
Operating Humidity Range		20 ~ 80% RH (No Condensation)			
Storage Humidity Range		80% RH or less(No Condensation)			
INTERFACE					
Standard		USB Host, LAN		USB Host, USB CDC, LAN	
Optional		GPIB (APS-001) RS232 / USB CDC (APS-002)		GPIB (APS-001) RS232 (APS-007)	
DIMENSIONS & WEIGHT					
		430(W) x 89(H) x 400(D) mm; Approx. 24Kg	430(W) x 89(H) x 560(D) mm; Approx. 38Kg	430(W) x 312(H) x 650(D) mm; Approx. 90Kg	430(W) x 400(H) x 650(D) mm; Approx. 128Kg

ORDERING INFORMATION

APS-7050	500VA Programmable AC Power Source	APS-7200	2000VA Programmable AC Power Source
APS-7100	1000VA Programmable AC Power Source	APS-7300	3000VA Programmable AC Power Source

ACCESSORIES :

CD ROM(User Manual, Programming Manual for APS-7000) x 1, Power Cord(Region Dependent), GTL-123 Test Lead

OPTIONAL ASSESSORIES

APS-001	GPIB interface card	APS-004	Output Frequency Capacity(45-999.9Hz)
APS-002	RS-232/USB interface card(APS-7050, APS-7100)	GRA-423	APS-7050, APS-7100 rack mount kit
APS-007	RS-232 interface card(APS-7200, APS-7300)	GRA-429	Rack mount kit (APS-7200)
APS-003	Output Voltage Capacity(0-600Vrms)	GRA-430	Rack mount kit (APS-7300)

500/1000/2000/3000 VA Programmable Linear AC Power Source

A. CONTROL PANEL CHARACTERISTICS

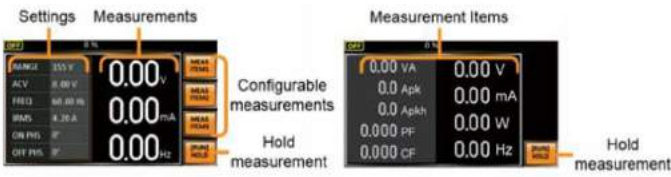

Standard Mode

Simple Mode

There are two control panel modes: Standard mode and Simple mode. Both modes are shown on the above. Standard mode combines settings and AC Power Meter measurement window display. Users apply Function key (F1–F3) to select required measurement items. There are nine items for selection. Simple mode shows all measurement items on the display.

B. REVERSE CURRENT DISPLAY



Standard Mode

Simple Mode

When output terminal detects 180 degree phase difference between voltage and current (reverse current), the front panel of APS-7000 Series will remind users the power and power factor measurement results in red numerical display. This feature can be applied to show the power and power factor measurement while testing inverter for feedback power grid. As shown on the above :
 APS-7000 Series can withstand reverse current: 30% of the maximum effective current or maximum current output within three minutes.

C. T IPEAK, HOLD FUNCTION

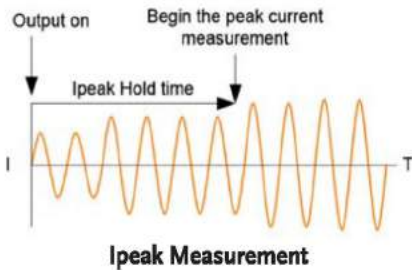

Ipeak Measurement

T, Ipk Hold sets delay time (1ms–60 seconds) for measurement after the output of Ipeak value and the maximum value will be retrieved. Update will be proceeded only if measured value is greater than the original value. Ipk Hold is for measuring transient inrush current as soon as the equipment power is on that is usually done by oscilloscope and current probe. T, Ipk Hold delay time setting can be applied to measure inrush current of sequentially activated DUT.

D. SEQUENCE MODE

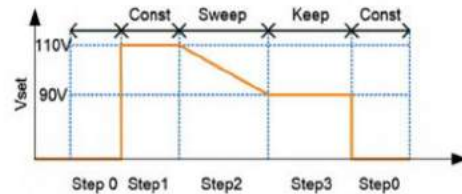

Sequence Mode

There are ten sets of Sequence mode and each set has 0–255 steps. The time setting range for each step is 0.01 – 999.99 seconds. Combining many sets of steps to edit required waveforms can satisfy users' requirement of highly complicated waveforms.

E. SIMULATE MODE

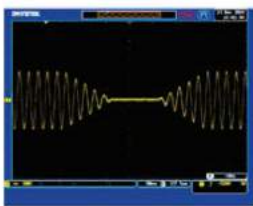

Power Outage

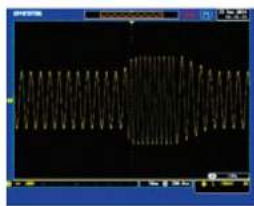

Voltage Rise

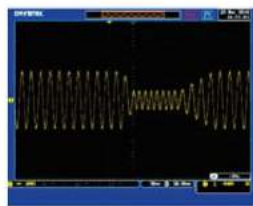

Voltage Fall

This mode can rapidly produce different simulated input transient waveforms such as power outage; voltage rise and voltage fall etc. for engineers to evaluate the impact on DUT posed by the transient phenomena. For instance, capacitor endurance test.

F. PROGRAM MODE

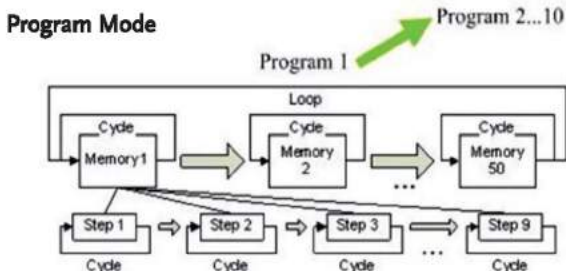

This mode allows users to set ceiling and floor specifications to produce PASS/FAIL result after the measurement is done. It can also show test results for each test procedure or only show the last result.

There are ten sets of Program mode and each set has 50 sets of memory. Each memory comprises 9 steps. Each Program will operate according to memory sequence, self-defined loops or designated steps to stop.

G SURGE/DIP CONTROL



Surge



Dip

Overlapping a Surge/Dip voltage on a normal voltage as the input power for DUT allows users to simulate Surge/Dip situation and evaluate DUT characteristics.

H. FUNCTION WAVEFORM (ARB) MODE

Provide waveforms in seven categories and 20,000 waveform combinations so as to rapidly simulate distorted AC voltage waveforms.

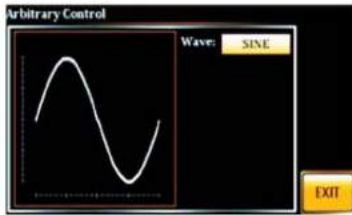

Sine Waveform
Standard AC Waveform

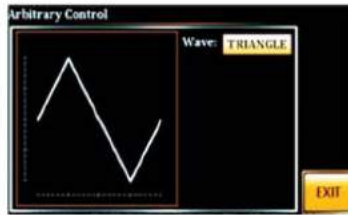

Triangle Waveform
Power Harmonic Output Simulation
Is Triangle Waveform



Staircase Waveform
Simulate Square Waveform And Staircase
Waveform For Commercial Ups

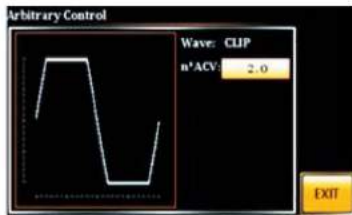

Clipped Sinewave
Simulate Grid Power Supply Heavy
Load Waveform

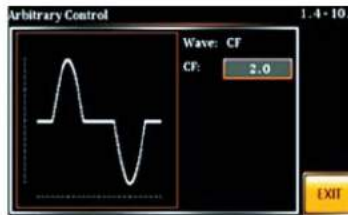

Crest Factor Waveform
Simulate Rectified Filter Current
Waveform By Capacitor Input

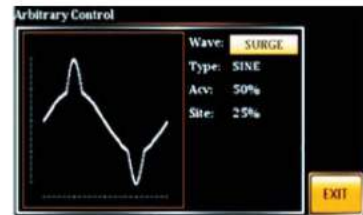

Surge Waveform
Simulate Grid Power Supply's
Peak Over-voltage



Fourier Series Synthesized Waveform

Simulate real output power waveform. Distorted power waveform is produced due to output impedance and non-linear effect such as inductance, capacitance, and parasitic capacitance effect. For example: motors.

I. RAMP CONTROL

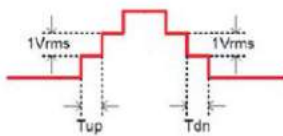

$T_{up} \rightarrow 0.1 \sim 999.9\text{ms}$
 $T_{dn} \rightarrow 0.1 \sim 999.9\text{ms}$

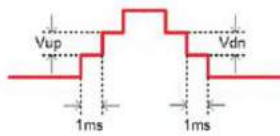

$V_{up} \rightarrow 0.01 \sim 99.99\text{Vrms}$
 $V_{dn} \rightarrow 0.01 \sim 99.99\text{Vrms}$

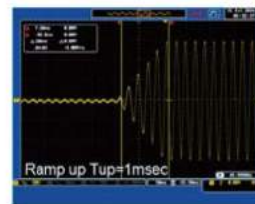

Mode=Time, $T_{up}=1\text{msec}$,
 $V_{AC}=100\text{V}$, Freq=50Hz,
Ramp output=on.

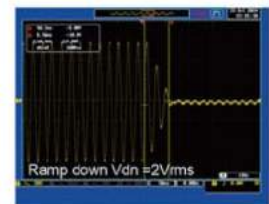

Mode=Voltage, $V_{dn}=2\text{Vrms}$,
 $V_{AC}=100\text{V}$, Freq=50Hz,
Ramp output=off.

Ramp control allows users to set output voltage rise or fall speed which is based on time (1 ms) or voltage (1Vrms) unit.

500/1000 VA AC Power Source



APS-7050E



APS-7100E



FEATURES

- * 4.3" large LCD Display
- * Output Capacity:
APS-7050E (500VA, 310Vrms, 4.2/2.1Arms)
APS-7100E (1000VA, 310Vrms, 8.4/4.2Arms)
- * Measurement Function :
Voltage, Current, Power, Frequency, Power Factor, Ipeak
- * Reverse Current Alarm Function
- * 10 Sets of The Test Mode Simulate Power Transient Output
- * 10 Sets of Preset Allow Users to Store Ten Settings
- * OCP/OPP/OTP Protection
- * Variable Voltage, Frequency and Current Limiter
- * Universal Power Inlet

GW Instek launches the APS-7000E series the economy version of the APS-7000 programmable AC power source. With the height of 2U, the maximum rated output for APS-7050E is 500VA, 310Vrms, 4.2Arms and APS-7100E is 1000VA, 310Vrms, 8.4Arms. The output frequency range of the series is 45~500Hz. The series is ideal for the test and development of DC power supply devices, consumer electronics, automotive electronics and electronic components.

The APS-7000E series comprises six measurement and test functions (Vrms, Irms, F, Ipk, W, PF), and provides user interface similar to that of AC Power Meter. The APS-7000E series, via switching many sets of current levels to increase small current measurement resolution, is ideal for the LED industry and standby mode power consumption test. Ten sets of Preset allow users to store ten settings.

To meet the test criteria of line voltage fluctuation often seen in consumer electronics, the APS-7000E series not only provides a stable AC power source but also features the Test mode to satisfy special or abnormal voltage and frequency variation demands. Ten sets of the Test mode simulate power outage, voltage rise, and voltage fall. The APS-7000E series that simulates waveforms of city power grid's transient changes is suitable for verifying electronics products operated under abnormal power source.

The APS-7000E series is the economy version of the APS-7000 series. If communications interface and larger voltage/frequency are required, please refer to the APS-7000 series.

SPECIFICATIONS			
Model		APS-7050E	APS-7100E
Power Rating		500VA	1000VA
Output Voltage		0 ~ 310.0 Vrms	0 ~ 310.0 Vrms
Output Frequency		45.00 ~ 500.0 Hz	45.00 ~ 500.0 Hz
Maximum Current (r.m.s)	0~155Vrms	4.2A	8.4A
	0~310Vrms	2.1A	4.2A
Maximum Current (peak)	0~155Vrms	16.8A	33.6A
	0~310Vrms	8.4A	16.8A
Total Harmonic Distortion (THD)		≤0.5% at 45 ~ 500Hz (Resistive Load)	
Crest Factor		≥4	
Line regulation		0.1% (% of full scale)	
Load regulation		0.5% (% of full scale)	
Response time		<100us	
SETTING			
Voltage	Range	155Vrms/310Vrms/Auto	
	Resolution	0.01V at 0.00 ~ 99.99Vrms; 0.1V at 100.0 ~ 310.0Vrms	
	Accuracy	±(0.5% of setting+2 counts)	
Frequency	Range	45 ~ 500Hz	
	Resolution	0.01Hz at 45.00 ~ 99.99Hz/0.1Hz at 100.0 ~ 500.0Hz	
	Accuracy	±0.02% of setting	
MEASUREMENT			
Voltage(RMS)	Range	0.20~38.75Vrms/38.76~77.50 Vrms/77.51~155.0Vrms/155.1~310.0Vrms	
	Resolution	0.01V at 0.00 ~ 99.99Vrms; 0.1V at 100.0 ~ 310.0Vrms	
	Accuracy	±(0.5% of reading + 2 counts)	
Frequency	Range	45 ~ 500Hz	
	Resolution	0.01Hz (at 45Hz~99.99Hz)/0.1Hz (at 100Hz~500.0Hz)	
	Accuracy	±0.1Hz	
Current(RMS)	Range	2.00 ~ 70.00mA/60.0 ~ 350.0mA/0.300 ~ 3.500A/3.00 ~ 17.5A	
	Resolution	0.01mA, 0.1mA, 0.001A, 0.01A	
	Accuracy	±(0.6% of reading+5 counts); 2.00~350.0mA/±(0.5% of reading+5 counts); 0.350~3.500A/±(0.5% of reading+3 counts);3.500~17.50A	
Current(Peak)	Range	0.0 ~ 70.0A	
	Resolution	0.1A	
	Accuracy	±(1% of reading+1 count)	
Power(W)	Resolution	0.01W, 0.1W, 1W	
	Accuracy	±(0.6% of reading+5 counts); 0.20~99.99W; ±(0.6% of reading+5 counts); 100.0~999.9W ±(0.6% of reading+2 counts); 1000~9999W	
Power Factor	Resolution	0.001	
	Accuracy	±(2% of reading + 2 counts)	
GENERAL			
Number of Preset		10 (0~9 Numeric keys)	
Protection		OCP, OPP, OTP and Alarm	



APS-7050E



APS-7100E

APS-7050E Rear Panel



APS-7100E Rear Panel



SPECIFICATIONS		
Model	APS-7050E	APS-7100E
ENVIRONMENT CONDITIONS		
Operation Temperature	0 ~ +40°C	
Storage Temperature	-10 ~ +70°C	
Operating Temperature	20 ~ 80% RH (No Condensation)	
Storage Humidity	80% RH or less (No Condensation)	
AC INPUT		
Input Power Source	1Φ AC 115/230Vac ±15%	
DIMENSIONS & WEIGHT		
	430(W) x 88(H) x 400(D) mm; Approx. 24Kg	430(W) x 88(H) x 560(D) mm; Approx. 38Kg

ORDERING INFORMATION

APS-7050E 500VA AC Power Source
APS-7100E 1000VA AC Power Source

ACCESSORIES :
 CD ROM (User Manual) x 1, Power Cord (Region Dependent), Mains Terminal Cover Set,
 GTL-123 Test Lead

OPTIONAL ASSESSORIES

GRA-423 Rack Mount Kit (APS-7000E Series)

Mains Terminal Cover Set

For: APS-7100/7100E Series



For: APS-7050/7050E Series



**APS-7000E Series
 Europe Type Output Outlet**





DC ELECTRONIC LOADS

Electronic loads provided by GW Instek are DC electronic loads which can be divided into three product series.

The PEL-3000 Series, a single channel programmable DC electronic load with 0.01mA current resolution and the current slew rate reaching $16A/\mu s$, is ideal for server power tests, SPS for commercial and industrial computers such as 24 hour non-stop cloud ecosystem. A single unit of the PEL-3000 Series provides up to 1050W. Via series or parallel connections, the PEL-3000 series provides the maximum output of 9450W.

PEL-2000A programmable DC electronic load can be operated under C.C., C.V., and C.R. modes. It can also simulate various kinds of dynamic loads. The PEL-2000A Series was a modulation design which intends to assist users to reserve the augmentation capability of future higher power requirements. Via parallel connections, the maximum of five units can be connected to output the maximum power of 7kVA.

Additionally, PEL-303xE is a single channel, 300W DC electronic load. Inherited from the PEL-3000 series, PEL-3000E has an easy-to-read LCD panel and user-friendly interface. This model features high speed and accurate measurement capability for the electronic component, battery, portable charger and power products that require low to medium power consumption.

PRODUCTS

- Programmable DC Electronic Loads (Includes High Power Capacity)
- Programmable DC Electronic Loads (Multi-channel)

DC ELECTRONIC LOADS

DC ELECTRONIC LOAD

Electronic load controls current, voltage and resistance. Electronic load is utilized to absorb power and its specifications are usually indicated by ampere, voltage and the maximum power.

Electronic loads are often categorized as resistant, inductive or capacitive. In the real tests, electronic load involves complex factors, including dynamic variation, C.V., C.C., C.R. or the control of power.

PROGRAMMABLE DC ELECTRONIC LOAD

Model	Operation Voltage	Operation Current	Power	Channel	Weight(kg)	Page
PEL-3021	0~ 150V	35A	175W	1	6	D69-74
PEL-3041	0~ 150V	70A	350W	1	7	
PEL-3111	0~ 150V	210A	1050W	1	17	
PEL-3211	0~ 150V	420A	2100W	1	23	
PEL-3212	0~ 150V	420A	2100W	1	67.5	
PEL-3322	0~ 150V	630A	3150W	1	73	
PEL-3323	0~ 150V	630A	3150W	1	85.5	
PEL-3424	0~ 150V	840A	4200W	1	110	
PEL-3533	0~ 150V	1050A	5250W	1	96.5	
PEL-3535	0~ 150V	1050A	5250W	1	127.5	
PEL-3744	0~ 150V	1470A	7350W	1	125	
PEL-3955	0~ 150V	1890A	9450W	1	149	
PEL-3021H	0~800V	8.75A	175W	1	6	
PEL-3041H	0~800V	17.5A	350W	1	7	
PEL-3111H	0~800V	52.5A	1050W	1	17	
PEL-3211H	0~800V	105A	2100W	1	23	
PEL-3212H	0~800V	105A	2100W	1	67.5	
PEL-3322H	0~800V	157.5A	3150W	1	73	
PEL-3323H	0~800V	157.5A	3150W	1	85.5	
PEL-3424H	0~800V	210A	4200W	1	110	
PEL-3533H	0~800V	262.5A	5250W	1	96.5	
PEL-3535H	0~800V	262.5A	5250W	1	127.5	
PEL-3744H	0~800V	367.5A	7350W	1	125	
PEL-3955H	0~800V	472.5A	9450W	1	149	
PEL-3031E	0~150V	60A	300W	1	7.5	D75-80
PEL-3032E	0~500V	15A	300W	1	7.5	
PEL-2020A	0~80V	20A	100/100W	2	3.8	D81-84
PEL-2030A	0~80V	5/40A	30/250W	2	3.8	
PEL-2040A	0~80V	70A	350W	1	3.8	
PEL-2041A	0~500V	10A	350W	1	3.8	

Programmable D.C. Electronic Load



PEL-3111(H)



PEL-3041(H)/3021(H)



FEATURES

- * Operating Voltage (DC) : 0~150V(PEL-3000)/ 0~800V(PEL-3000H)
- * Operating Mode : C.C/C.V/C.R/C.P/C.C+C.V/ C.R+C.V/C.P+C.V
- * Parallel Connection of Inputs for Higher Capacity (Max : 9,450W)
- * Support of High Slew Rate : Max 16A/ μ s (PEL-3000)/0.84A/ μ s(PEL-3000H)
- * Run Program Function (Go/NoGo Test)
- * Sequence Function for High Efficient Load Simulations
- * Dynamic (Switching) Function : 0.0166Hz~20kHz
- * Soft Start Function : Off/On (1~200ms, Res. 1ms)
- * Adjustable OCP/OVP/OPP/UVP Setting
- * Short Circuit Function
- * Timer Function : Elapsed Time of Load on
- * Cut Off Time (Auto Load Off Timer) : 1s to 999h 59min 59s or Off
- * External Channel Control/Monitoring Via Analog Control Connector
- * Setup Memories : 100 sets
- * 3.5 Inch TFT LCD Display
- * Multi Interface : USB 2.0 Device/Host, RS-232, GPIB (Optional)

Rear Panel



The PEL-3000 Series, a single-channel, programmable D.C. electronic load with 0.01mA current resolution and 16A/ μ s current Slew Rate, is very ideal for testing server power supply and SPS(Switching Power Supply) for commercial and industrial computers. For a heavy-duty device like cloud ecosystem running 24-hour nonstop operations, a stable and high-power power supply, ranging from 350W to 1500W, is required to maintain the normal operation of server, Hub, and the equipment of data storage and internet communications. Owing to the increasing demand of data transmission and large scale data storage of telecommunications systems, the infrastructure of internet communications is in the pace of rapid expansion. This has greatly boosted the market demand of telecommunications equipment powered by power supply of 2000W and above. The flexible power combination of PEL-3000 Series meets the test requirements of present high-power power supply. The PEL-3000H Series programmable DC Electronic load, which not only inherited functions and features from the PEL-3000 Series but providing three current ranges for all PEL-3000H Series and adding voltage monitor BNC terminals on the front panel. The PEL-3000H Series, a single-channel, programmable D.C. electronic load with 800V and 0.84A/ μ s current Slew Rate, is ideal for the test of the high voltage devices such as the EV & HEV in-vehicle chargers, DC/DC converters or high-voltage batteries. With respect to battery testing applications such as rechargeable battery for electrical tools, battery module and automobile battery, PEL-3000(H) Series has three stand-alone models to offer including 175W, 350W, 1050W and Booster. By connecting Booster 2100W units with master units, the maximum load capacity of the whole system can reach 9,450W. Hence, the PEL-3000(H) Series fulfills various power testing requirements including medium to low power or high-power power supply.

The PEL-3000(H) Series has seven operating modes and three operating functions. Among the seven operating modes, four of them are basic operating modes, including constant current, constant voltage, constant resistance, and constant power, and the other three are advanced operating modes including constant current + constant voltage, constant resistance + constant voltage, and constant power + constant voltage. Users must first select operating mode and then operating function based upon the test requirements. Static, Dynamic and Sequence operating functions can be applied to different testing conditions including a fixed load level, switching between two levels or switching among more than two levels. Sequence function is divided into Fast Sequence and Normal Sequence according to the test time of each step. Both Dynamic and Sequence are to assist users to simulate the genuine load change. For instance, PEL-3000(H) Series can simulate HEV current consumption to make sure that automobile battery can supply HEV with sufficient power need on the road. By so doing, manufacturers can elevate product quality and reliability.

The Soft Start function of the PEL-3000(H) Series can set current rise time for the moment PEL-3000(H) Series is turned on to reduce the abnormal situation of the voltage drop of power supply under test. The adjustable Under Voltage Protection(UVP), GO/NO GO voltage input monitoring function, current monitoring function and Timer Function to control load activation time can be jointly applied to the characteristic tests of battery bleeding to avoid battery damage during bleeding operation. Based upon the functionalities described above, the PEL-3000(H) Series can test a vast variety of power supply ranging from the fundamental static sink current to complex dynamic load simulations so as to enhance product quality and reliability.

The single unit D.C Electronic Load of PEL-3000(H) Series

The PEL-3000(H) Series is a high speed, single channel and programmable D.C. electronic load and its power, functionality, parallel combination and size are listed on the following chart :

MODEL	PEL-3021(H)	PEL-3041(H)	PEL-3111(H)	PEL-3211(H)
Power	175W	350W	1,050W	2,100W Booster
Function	Full-function Single Unit	Full-function Single Unit	Full-function Single Unit	No control panel, can not be operated alone
Parallel Combination	Parallel with same model, 5 units the maximum	Parallel with same model, 5 units the maximum	Parallel with same model, 5 units the maximum Parallel with the maximum of four PEL-3211(H)s	Parallel with PEL-3111(H)
Size	Half Rack	Half Rack	Full Rack	Full Rack

Note:

- *1. Full scale of H range
- *2. Vin: input terminal voltage of electronic load
- *3. M range applies to the full scale of H range
- *4. Siemens[S] = Input current[A]/Input voltage[V] = 1/resistance[Ω]
- *5. Converted value at the input current. At the input current. It is not applied for the condition of the parallel operation.
- *6. set = Vin/Rset
- *7. At the sensing point during remote sensing under the operating range of the input voltage. It is also applied for the condition of the parallel operation.
- *8. It is not applied for the condition of the parallel operation.
- *9. Time to reach from 10% to 90% when the current is varied from 2% to 100% (20% to 100% in M range) of the rated current.

SPECIFICATIONS

Model	PEL-3021			PEL-3041			PEL-3111			PEL-3211		
Voltage	0V~150V			0V~150V			0V~150V			0V~150V		
Current	35A			70A			210A			420A		
Power	175W			350W			1050W			2100W		
Input Resistance	500 kΩ			500 kΩ			500 kΩ			N/A		
Min. Operating Voltage(DC)(Typ.)	0.75V@17.5A 1.5V@35A			0.75V@35A 1.5V@70A			0.75V@105A 1.5V@210A			0.75V@210A 1.5V@420A		
CONSTANT CURRENT MODE												
Operating Range	H, M, L	0~35A	0~3.5A	0~0.35A	0~70A	0~7A	0~0.7A	0~210A	0~21A	0~2.1A	420A	
Accuracy of Setting	H, M, L	$\pm(0.2\% \text{ of set} + 0.1\% \text{ of f.s.}^{\text{①}}) + \text{Vin}^{\text{②}}/500 \text{ k}\Omega$									$\pm(1.2\% \text{ of set} + 1.1\% \text{ of f.s.})$	
Accuracy of Setting(Parallel)	H, M, L	$\pm(1.2\% \text{ of set} + 1.1\% \text{ of f.s.}^{\text{③}})$									$\pm(1.2\% \text{ of set} + 1.1\% \text{ of f.s.})$	
Resolution	H, M, L	1mA	0.1mA	0.01mA	2mA	0.2mA	0.02mA	10mA	1mA	0.1mA	N/A	
CR MODE												
Operating Range	Range	H	23.3336S~400μS (42.857mΩ~2.5kΩ)			46.6672S~800μS (21.428mΩ~1.25kΩ)			140.0016S~2.4mS (7.1427mΩ~416.6667Ω)			28.0002s~484.8μs (35.7135mΩ~2.08334Ω)
		M	2.33336S~40μS (428.566mΩ~25kΩ)			4.6667S~80μS (214.28mΩ~12.5kΩ)			14.0001S~242.4μS (71.427mΩ~4.16667kΩ)			
		L	0.233336S~4μS (4.28566Ω~250kΩ)			0.46667S~8μS (2.1428Ω~125kΩ)			1.40001S~24.24μS (714.27mΩ~41.6667kΩ)			
Accuracy of Setting	H, M, L	$\pm(0.5\% \text{ of set}^{\text{④}} + 0.5\% \text{ of f.s.}^{\text{⑤}}) + \text{Vin}^{\text{⑥}}/500 \text{ k}\Omega$									$\pm(1.2\% \text{ of set} + 1.1\% \text{ of f.s.})$	
Parallel	$\pm(1.2\% \text{ of set} + 1.1\% \text{ of f.s.}^{\text{⑦}})$											
Resolution	H, M, L	400μS	40μS	4μS	800μS	80μS	8μS	2.4mS	240μS	24μS	N/A	
CONSTANT VOLTAGE MODE												
Operating Range	Range	H	1.5V~150V									1.5V~150V
		L	1.5V~15V									1.5V~15V
Accuracy of Setting	H, L	$\pm(0.1\% \text{ of set} + 0.1\% \text{ of f.s.})$									N/A	
Resolution	H, L	10mV/1mV									N/A	
CONSTANT POWER MODE												
Operating Range	Range	H	17.5W~175W			35W~350W			105W~1050W			210W~2100W
		M	1.75W~17.5W			3.5W~35W			10.5W~105W			21W~210W
		L	0.175W~1.75W			0.35W~3.5W			1.05W~10.5W			2.1W~21W
Accuracy of Setting	H, M, L	$\pm(0.6\% \text{ of set}^{\text{⑧}} + 1.4\% \text{ of f.s.}^{\text{⑨}})$									N/A	
Resolution	H, M, L	10mW	1mW	0.1mW	10mW	1mW	0.1mW	100mW	10mW	1mW	N/A	
PARALLEL Mode												
Capacity	875W			1750W			5250W			PEL-3111 with 4 booster units : Max 9.45kW		
SLEW RATE												
Operation Mode	CC, CR			CC, CR			CC, CR			N/A		
Setting Range (CC mode)	Range	H	2.5mA/μs~2.5A/μs			5mA/μs~5A/μs			16mA/μs~16A/μs			16mA/μs~16A/μs
		M	250μA/μs~250mA/μs			500μA/μs~500mA/μs			1.6mA/μs~1.6A/μs			1.6mA/μs~1.6A/μs
		L	25μA/μs~25mA/μs			50μA/μs~50mA/μs			160μA/μs~160mA/μs			N/A
Setting Range (CR Mode)	Range	H	250μA/μs~250mA/μs			500μA/μs~500mA/μs			1.6mA/μs~1.6A/μs			1.6mA/μs~1.6A/μs
		M	25μA/μs~25mA/μs			50μA/μs~50mA/μs			160μA/μs~160mA/μs			160μA/μs~160mA/μs
		L	2.5μA/μs~2.5mA/μs			5μA/μs~5mA/μs			16μA/μs~16mA/μs			N/A
Accuracy of Setting	H, M, L	$\pm(10\% \text{ of set}^{\text{⑩}} + 5\mu\text{s})$									N/A	
Resolution			1mA(250mA~2.5A/μs) 100μA(25mA~250mA/μs) 10μA(2.5mA~25mA/μs) 1μA(250μA~2.5mA/μs) 100nA(25μA~250μA/μs) 10nA(2.5μA~25μA/μs)			2mA(500mA~5A/μs) 200μA(50mA~500mA/μs) 20μA(5mA~25mA/μs) 2μA(500μA~5mA/μs) 200nA(50μA~500μA/μs) 20nA(5μA~50μA/μs)			6mA(1.6A~16A/μs) 600μA(160mA~1.6A/μs) 60μA(16mA~160mA/μs) 6μA(1.6mA~16mA/μs) 600nA(160μA~1.6mA/μs) 60nA(16μA~160μA/μs)			N/A
METER												
Voltmeter	Accuracy	$\pm(0.1\% \text{ of rdg} + 0.1\% \text{ of f.s.})$									N/A	
Ammeter	Accuracy	$\pm(0.2\% \text{ of rdg} + 0.3\% \text{ of f.s.})$										
Ammeter(Parallel Operation)	Accuracy	$\pm(1.2\% \text{ of rdg} + 1.1\% \text{ of f.s.})$										
DYNAMIC MODE												
Operation Mode	CC and CR											
T1 & T2	0.025mS~10mS/Res : 1μs ; 1ms~30s/Res : 1ms											
Accuracy	1μS/1ms ± 100ppm											
Slew Rate (CC Mode)	Range	H	2.5mA/μs~2.5A/μs			5mA/μs~5A/μs			16mA/μs~16A/μs			16mA/μs~16A/μs
		M	250μA/μs~250mA/μs			500μA/μs~500mA/μs			1.6mA/μs~1.6A/μs			1.6mA/μs~1.6A/μs
		L	25μA/μs~25mA/μs			50μA/μs~50mA/μs			160μA/μs~160mA/μs			N/A
Slew Rate (CR Mode)	Range	H	250μA/μs~250mA/μs			500μA/μs~500mA/μs			1.6mA/μs~1.6A/μs			N/A
		M	25μA/μs~25mA/μs			50μA/μs~50mA/μs			160μA/μs~160mA/μs			
		L	2.5μA/μs~2.5mA/μs			5μA/μs~5mA/μs			16μA/μs~16mA/μs			
Current Accuracy	$\pm 0.4\% \text{ F.S.}$											
PROTECTION FUNCTION												
Functions	Overvoltage protection(OVP), Overcurrent protection(OCP), Overpower protection(OPP), Overheat protection(OHP), Undervoltage protection(UVP), Reverse connection protection(REV)											
GENERAL												
Input Range	90VAC~132VAC/180VAC~250VAC Single-phase; 47Hz~63Hz											
Power(Max.)	90VA			110VA			190VA			230VA		
Interface	USB/RS232/Analog Control (Standard) ; GPIB(Optional)											
Dimensions & Weight	214.5(W)x124(H)x400(D)mm; Approx. 6kg			214.5(W)x124(H)x400(D)mm; Approx. 7kg			429.5(W)x128(H)x400(D)mm; Approx. 17kg			427.7(W)x128(H)x592.5(D)mm; Approx. 23kg		

Programmable D.C. Electronic Load

PEL-3000/3000(H) Series

ELECTRONIC LOAD

SPECIFICATIONS																										
Model	PEL-3212			PEL-3323			PEL-3424			PEL-3535			PEL-3322			PEL-3533			PEL-3744			PEL-3955				
Voltage	0V~150V			0V~150V			0V~150V			0V~150V			0V~150V			0V~150V			0V~150V			0V~150V				
Current	0~420A			0~630A			0~840A			0~1050A			0~630A			0~1050A			0~1470A			0~1890A				
Power	2100W			3150W			4200W			5250W			3150W			5250W			7350W			9450W				
Input Resistance	250 kΩ			166.7 kΩ			125 kΩ			100 kΩ			500 kΩ			500 kΩ			500 kΩ			500 kΩ				
Min. Operating Voltage(DC)(Typ.)	0.75V@210A			0.75V@315A			0.75V@420A			0.75V@525A			0.75V@315A			0.75V@525A			0.75V@735A			0.75V@945A				
	1.5V@420A			1.5V@630A			1.5V@840A			1.5V@1050A			1.5V@630A			1.5V@1050A			1.5V@1470A			1.5V@1890A				
CONSTANT CURRENT MODE																										
Operating Range	H,M,L	0~420A	0~42A	0~4.2A	0~630A	0~63A	0~6.3A	0~840A	0~84A	0~8.4A	0~1050A	0~105A	0~10.5A	0~630A	0~63A	N/A	0~1050A	0~105A	N/A	0~1470A	0~147A	N/A	0~1890A	0~189A	N/A	
Accuracy of Setting	H,M,L	$\pm(0.2\% \text{ of set} + 0.1\% \text{ of f.s.}^{\text{①}}) + \text{Vin}^2/500\text{k}\Omega$																								
Resolution	H,M,L	20mA	2mA	0.2mA	30mA	3mA	0.3mA	40mA	4mA	0.4mA	50mA	5mA	0.5mA	30mA	3mA	N/A	50mA	5mA	N/A	70mA	7mA	N/A	90mA	9mA	N/A	
CR MODE																										
Operating Range	Range	H	280.0032S~4.8mS (3.57138mΩ~208.333Ω)			420.0048S~7.2mS (2.38092mΩ~138.888Ω)			560.0064S~9.6mS (1.78569mΩ~104.166Ω)			700.008S~12mS (1.42855mΩ~83.333Ω)			420.0048S~7.2mS (2.38092mΩ~138.888Ω)			700.008S~12mS (1.42855mΩ~83.333Ω)			980.0112S~16.8mS (1.02039mΩ~59.5238Ω)			1260.0144S~21.6mS (793.641μΩ~46.2963Ω)		
		M	28.00032S~480μS (35.7138mΩ~2083.33Ω)			42.00048S~720μS (23.8092mΩ~1388.88Ω)			56.00064S~960μS (17.8569mΩ~1041.66Ω)			70.0008S~1.2mS (14.2855mΩ~833.333Ω)			42.00048S~720μS (23.8092mΩ~1388.88Ω)			70.0008S~1.2mS (14.2855mΩ~833.333Ω)			98.00112S~1.68mS (10.2039mΩ~595.238Ω)			126.00144S~2.16mS (7.93641mΩ~462.963Ω)		
		L	2.800032S~48μS (357.138mΩ~20.8333kΩ)			4.200048S~72μS (238.092mΩ~13.8888kΩ)			5.600064S~96μS (178.569mΩ~10.4166kΩ)			7.00008S~120μS (142.855mΩ~8.33333kΩ)			N/A			N/A			N/A			N/A		
Accuracy of Setting	H,M,L	$\pm(0.5\% \text{ of set}^{\text{②}} + 0.5\% \text{ of f.s.}^{\text{③}}) + \text{Vin}^2/500\text{k}\Omega$																								
Resolution	H,M,L	4.8mS	480μS	48μS	7.2mS	720μS	72μS	9.6mS	960μS	96μS	12mS	1.2mS	120μS	7.2mS	720μS	-	12mS	1.2mS	-	16.8mS	1.68mS	-	21.6mS	2.16mS	-	
CONSTANT VOLTAGE MODE																										
Operating Range	Range	H	1.5V~150V			1.5V~15V			1.5V~15V			1.5V~15V			1.5V~15V			1.5V~15V			1.5V~15V			1.5V~15V		
		L	1.5V~15V			1.5V~15V			1.5V~15V			1.5V~15V			1.5V~15V			1.5V~15V			1.5V~15V			1.5V~15V		
Accuracy of Setting	H,L	$\pm(0.1\% \text{ of set} + 0.1\% \text{ of f.s.})$																								
Resolution	H,L	10mV/1mV																								
CONSTANT POWER MODE																										
Operating Range	Range	H	210W~2100W			315W~3150W			420W~4200W			525W~5250W			315W~3150W			525W~5250W			735W~7350W			945W~9450W		
		M	21W~210W			31.5W~315W			42W~420W			52.5W~525W			31.5W~315W			52.5W~525W			93.5W~735W			94.5W~945W		
		L	2.1W~21W			3.15W~31.5W			4.2W~42W			5.25W~52.5W			N/A			N/A			N/A			N/A		
Accuracy of Setting	H,M,L	$\pm(0.6\% \text{ of set} + 1.4\% \text{ of f.s.}^{\text{④}})$																								
Resolution	H,M,L	200mW	20mW	2mW	300mW	30mW	3mW	400mW	40mW	4mW	500mW	50mW	5mW	300mW	30mW	-	500mW	50mW	-	700mW	70mW	-	900mW	90mW	-	
PARALLEL Mode																										
Capacity	-																									
SLEW RATE																										
Operation Mode	CC, CR																									
Setting Range (CC Mode)	Range	H	32mA/μs~16A/μs			48mA/μs~16A/μs			64mA/μs~16A/μs			80mA/μs~16A/μs			48mA/μs~16A/μs			80mA/μs~16A/μs			112mA/μs~16A/μs			144mA/μs~16A/μs		
		M	3.2mA/μs~1.6A/μs			4.8mA/μs~1.6A/μs			6.4mA/μs~1.6A/μs			8mA/μs~1.6A/μs			4.8mA/μs~1.6A/μs			8mA/μs~1.6A/μs			11.2mA/μs~1.6A/μs			14.4mA/μs~1.6A/μs		
		L	320μA/μs~160mA/μs			480μA/μs~160mA/μs			640μA/μs~160mA/μs			800μA/μs~160mA/μs			N/A			N/A			N/A			N/A		
Setting Range (CR Mode)	Range	H	3.2mA/μs~1.6A/μs			4.8mA/μs~1.6A/μs			6.4mA/μs~1.6A/μs			8mA/μs~1.6A/μs			4.8mA/μs~1.6A/μs			8mA/μs~1.6A/μs			11.2mA/μs~1.6A/μs			14.4mA/μs~1.6A/μs		
		M	320μA/μs~160mA/μs			480μA/μs~160mA/μs			640μA/μs~160mA/μs			800μA/μs~160mA/μs			480μA/μs~160mA/μs			800μA/μs~160mA/μs			1.12mA/μs~160mA/μs			1.44mA/μs~160mA/μs		
		L	32μA/μs~16mA/μs			48μA/μs~16mA/μs			64μA/μs~16mA/μs			80μA/μs~16mA/μs			N/A			N/A			N/A			N/A		
Accuracy of Setting	H,M,L	$\pm(10\% \text{ of set}^{\text{⑤}} + 5\mu\text{s})$																								
Resolution	12mA(1.6A~16A/μs)																									
	1.2mA(160mA~1.6A/μs)																									
	120μA(16mA~160mA/μs)																									
	12μA(1.6mA~16mA/μs)																									
	1.2μA(160μA~1.6mA/μs)																									
	120nA(16μA~160μA/μs)																									
18mA(1.6A~16A/μs)																										
1.8mA(160mA~1.6A/μs)																										
180μA(16mA~160mA/μs)																										
18μA(1.6mA~16mA/μs)																										
1.8μA(160μA~1.6mA/μs)																										
180nA(16μA~160μA/μs)																										
24mA/μs(1.6A~16A/μs)																										
2.4mA/μs(160mA~1.6A/μs)																										
240μA/μs(16mA~160mA/μs)																										
24μA/μs(1.6mA~16mA/μs)																										
2.4μA/μs(160μA~1.6mA/μs)																										
240nA/μs(16μA~160μA/μs)																										
30mA(1.6A~16A/μs)																										
3mA(160mA~1.6A/μs)																										
300μA(16mA~160mA/μs)																										
30μA(1.6mA~16mA/μs)																										
3μA(160μA~1.6mA/μs)																										
300nA(16μA~160μA/μs)																										
18mA(1.6A~16A/μs)																										
1.8mA(160mA~1.6A/μs)																										
180μA(16mA~160mA/μs)																										
18μA(1.6mA~16mA/μs)																										
1.8μA(160μA~1.6mA/μs)																										
N/A																										
N/A																										
N/A																										
N/A																										
N/A																										
N/A																										
METER																										
Voltmeter Accuracy	$\pm(0.1\% \text{ of rdg} + 0.1\% \text{ of f.s.})$																									
Ammeter Accuracy	$\pm(0.2\% \text{ of rdg} + 0.3\% \text{ of f.s.})$																									
DYNAMIC MODE																										
Operation Mode	CC and CR																									
T1 & T2 Accuracy	0.025mS~10mS/Res: 1μs; 1mS~30S/Res: 1mS 1μS/1ms \pm 100ppm																									
Slew Rate (CC Mode)	Range	H	32mA/μs~16A/μs			48mA/μs~16A/μs			64mA/μs~16A/μs			80mA/μs~16A/μs			48mA/μs~16A/μs			80mA/μs~16A/μs			112mA/μs~16A/μs			144mA/μs~16A/μs		
		M	3.2mA/μs~1.6A/μs			4.8mA/μs~1.6A/μs			6.4mA/μs~1.6A/μs			8mA/μs~1.6A/μs			4.8mA/μs~1.6A/μs			8mA/μs~1.6A/μs			11.2mA/μs~1.6A/μs			14.4mA/μs~1.6A/μs		
		L	320μA/μs~160mA/μs			480μA/μs~160mA/μs			640μA/μs~160mA/μs			800μA/μs~160mA/μs			N/A			N/A			N/A			N/A		
Slew Rate (CR Mode)	Range	H	3.2mA/μs~1.6A/μs			4.8mA/μs~1.6A/μs			6.4mA/μs~1.6A/μs			8mA/μs~1.6A/μs			4.8mA/μs~1.6A/μs			8mA/μs~1.6A/μs			11.2mA/μs~1.6A/μs			14.4mA/μs~1.6A/μs		
		M	320μA/μs~160mA/μs			480μA/μs~160mA/μs			640μA/μs~160mA/μs			800μA/μs~160mA/μs			480μA/μs~160mA/μs			800μA/μs~160mA/μs			1.12mA/μs~160mA/μs			1.44mA/μs~160mA/μs		
		L	32μA/μs~16mA/μs			48μA/μs~16mA/μs			64μA/μs~16mA/μs			80μA/μs~16mA/μs			N/A			N/A			N/A			N/A		
Current Accuracy	$\pm 0.4\% \text{ F.S.}$																									
PROTECTION FUNCTION																										
Functions	Overvoltage protection (OVP), Overcurrent protection (OCP), Overpower protection (OPP), Overheat protection (OHP), Undervoltage protection (UVP), Reverse connection protection (REV)																									
GENERAL																										
Input Range	90VAC~132VAC/180VAC~250VAC Single-phase; 47Hz~63Hz																									
Power(Max.)	380VA			570VA			760VA			950VA			420VA			650VA			880VA			1110VA				
Interface	USB/RS232/Analog Control (Standard); GPIB(Optional)																									
Dimensions & Weight	598(W)x877(H)x706(D)mm; Approx. 67.5kg			598(W)x877(H)x706(D)mm; Approx. 85.5kg			598(W)x877(H)x706(D)mm; Approx. 110kg			598(W)x877(H)x706(D)mm; Approx. 127.5kg			598(W)x877(H)x706(D)mm; Approx. 73kg			598(W)x877(H)x706(D)mm; Approx. 96.5kg			598(W)x877(H)x706(D)mm; Approx. 125kg			598(W)x877(H)x706(D)mm; Approx. 149kg				

SPECIFICATIONS

Model	PEL-3021H			PEL-3041H			PEL-3111H			PEL-3211H			
Voltage	0V~800V			0V~800V			0V~800V			0V~800V			
Current	8.75A			17.5A			52.5A			105A			
Power	175W			350W			1050W			2100W			
Input Resistance	3.24MΩ			3.24MΩ			3.24MΩ			N/A			
Min. Operating Voltage(DC)(Typ.)	5V@8.75A 2.5V@4.375A			5V@17.5A 2.5V@8.75A			5V@52.5A 2.5V@26.25A			5V@105A 2.5V@52.5A			
CONSTANT CURRENT MODE													
Operating Range	H, M, L	0~8.75A 0~875mA 0~87.5mA			0~17.5A 0~1.75A 0~175mA			0~52.5A 0~5.25A 0~525mA			0~105A 0~10.5A 0~1.05A		
Accuracy of Setting	H, M, L	$\pm(0.2\% \text{ of set} + 0.1\% \text{ of f.s.}^{(1)}) + \text{Vin}^2/3.24\text{M}\Omega$										$\pm(1.2\% \text{ of set} + 1.1\% \text{ of f.s.})$	
Accuracy of Setting(Parallel)	H, M, L	$\pm(1.2\% \text{ of set} + 1.1\% \text{ of f.s.}^{(1)})$										$\pm(1.2\% \text{ of set} + 1.1\% \text{ of f.s.})$	
Resolution	H, M, L	300μA	30μA	3μA	0.6mA	60μA	6μA	2mA	200μA	20μA	N/A		
CR MODE													
Operating Range	Range	H	1.75S~30μS (571Ω~33.3MΩ)			3.5S~60μS (285mΩ~16.6kΩ)			10.5S~180μS (95.2mΩ~5.55kΩ)			21S~360μS (95.2mΩ~2.777kΩ)	
		M	1.75mS~3μS (5.71Ω~333MΩ)			350mS~6μS (2.85mΩ~166kΩ)			1.05S~18μS (952mΩ~55.5kΩ)			2.1S~36μS (476mΩ~27.77kΩ)	
		L	17.5mS~0.3μS (57.1Ω~3.33MΩ)			35mS~0.6μS (28.5mΩ~1.66MΩ)			105mS~1.8μS (9.52Ω~555kΩ)			210mS~3.6μS (4.762Ω~277.7kΩ)	
Accuracy of Setting	H, M, L	$\pm(0.5\% \text{ set} + 0.5\% \text{ f.s.}^{(1)}) + \text{Vin}^2/3.24\text{M}\Omega$										$\pm(1.2\% \text{ of set} + 1.1\% \text{ of f.s.})$ TYP	
Parallel		$\pm(1.2\% \text{ of set} + 1.1\% \text{ of f.s.}^{(1)})$										N/A	
Resolution	H, M, L	30μS	3μS	0.3μS	60μS	6μS	0.6μS	180μS	18μS	1.8μS	N/A		
CONSTANT VOLTAGE MODE													
Operating Range	Range	H	5V~800V									5V~800V	
		L	5V~80V									5V~80V	
Accuracy of Setting	Range	H, L	$\pm(0.2\% \text{ of set} + 0.2\% \text{ of f.s.})$									$\pm(0.2\% \text{ of set} + 0.2\% \text{ of f.s.})$	
	Parallel	TYP	$\pm(0.2\% \text{ of set} + 0.2\% \text{ of f.s.})$									$\pm(0.2\% \text{ of set} + 0.2\% \text{ of f.s.})$	
Resolution	Range	H, L	20mV/2mV									N/A	
CONSTANT POWER MODE													
Operating Range	Range	H	17.5W~175W			35W~350W			105W~1050W			210W~2100W	
		M	1.75W~17.5W			3.5W~350W			10.5W~105W			21W~210W	
		L	0.175W~1.75W			0.35W~10.5W			1.05W~10.5W			2.1W~21W	
Accuracy of Setting	H, M	$\pm(0.6\% \text{ of set} + 1.4\% \text{ of f.s.}) + \text{Vin}/3.24\text{M}\Omega$										$\pm(5\% \text{ of f.s.})$ TYP	
Resolution	H, M, L	10mW	1mW	0.1mW	10mW	1mW	0.1mW	100mW	10mW	1mW	N/A		
PARALLEL Mode													
Capacity		875W			1750W			5250W			PEL-3111H with 4 booster units : Max 9.45kW		
SLEW RATE													
Operation Mode		CC, CR			CC, CR			CC, CR			N/A		
Setting Range (CC mode)	Range	H	0.14mA/μs~140mA/μs			0.280mA/μs~280.0mA/μs			0.840mA/μs~840mA/μs			N/A	
		M	0.014mA/μs~14mA/μs			0.0280mA/μs~28.00mA/μs			0.0840mA/μs~84.00mA/μs			N/A	
		L	1.4μA/μs~1400μA/μs			2.80μA/μs~2800μA/μs			0.00840mA/μs~8.400mA/μs			N/A	
Setting Range (CR Mode)	Range	H	0.014mA/μs~14mA/μs			0.0280mA/μs~28.00mA/μs			0.0840mA/μs~84.00mA/μs			N/A	
		M	0.0014mA/μs~1.4mA/μs			0.00280mA/μs~2.800mA/μs			0.00840mA/μs~8.400mA/μs			N/A	
		L	0.14μA/μs~140μA/μs			0.280μA/μs~280.0μA/μs			0.000840mA/μs~0.8400mA/μs			N/A	
Accuracy of Setting	H, M, L	$\pm(10\% \text{ of set} + 25\mu\text{s})$										N/A	
Resolution		50μA(14mA~140mA/μs) 5μA(1.4mA~14mA/μs) 0.5μA(140μA~1.4mA/μs) 50nA(14μA~140μA/μs) 5nA(1.4μA~14μA/μs) 0.5nA(0.14μA~1.4μA/μs)			100μA(28mA~280mA/μs) 10μA(2.8mA~28mA/μs) 1μA(280μA~2.8mA/μs) 0.1μA(28μA~280μA/μs) 10nA(2.8μA~28μA/μs) 1nA(0.28μA~2.8μA/μs)			300μA(84mA~0.84A/μs) 30μA(8.4mA~84mA/μs) 3μA(840μA~8.4mA/μs) 0.3μA(84μA~840μA/μs) 30nA(8.4μA~84μA/μs) 3nA(0.84μA~8.4μA/μs)			N/A		
METER													
Voltmeter	Accuracy	$\pm(0.1\% \text{ of rdg} + 0.1\% \text{ of f.s.})$										$\pm(0.1\% \text{ of rdg} + 0.1\% \text{ of f.s.})$ TYP	
Ammeter	Accuracy	$\pm(0.2\% \text{ of rdg} + 0.3\% \text{ of f.s.})$										N/A	
Ammeter(Parallel Operation)	Accuracy	$\pm(1.2\% \text{ of rdg} + 1.1\% \text{ of f.s.})$										$\pm(1.2\% \text{ of rdg} + 1.1\% \text{ of f.s.})$ TYP	
DYNAMIC MODE													
Operation Mode		CC, CR, CP										N/A	
T1 & T2 Accuracy		0.025mS~10mS/Res : 1μs ; 10ms~60s/Res : 1ms $\pm 100\text{ppm}$ of setting										N/A N/A $\pm 100\text{ppm}$ of setting	
Slew Rate (CC Mode)	Range	H	0.140mA/μs~140.0A/μs			0.280mA/μs~280.0A/μs			0.840mA/μs~840.0mA/μs			N/A	
		M	0.014mA/μs~14.00mA/μs			0.028mA/μs~28.00mA/μs			0.084mA/μs~84.00A/μs			N/A	
		L	1.400μA/μs~1400.0μA/μs			2.800μA/μs~2800μA/μs			0.0084mA/μs~8.400mA/μs			N/A	
Slew Rate (CR Mode)	Range	H	0.014mA/μs~14.000mA/μs			0.028mA/μs~28.00mA/μs			0.084mA/μs~84.00mA/μs			N/A	
		M	0.0014mA/μs~1.4000mA/μs			0.028mA/μs~2.800mA/μs			0.0084mA/μs~8.400mA/μs			N/A	
		L	0.1400μA/μs~140.00μA/μs			0.280μA/μs~280.0μA/μs			0.00084mA/μs~0.8400mA/μs			N/A	
Current Accuracy		$\pm 0.4\% \text{ F.S.}$										$\pm 0.4\% \text{ F.S.}$	
PROTECTION FUNCTION													
Functions		Overvoltage protection (OVP), Overcurrent protection (OCP), Overpower protection (OPP), Overheat protection (OHP), Undervoltage protection (UVP), Reverse connection protection (REV)											
GENERAL													
Input Range		90VAC~132VAC/180VAC~250VAC Single-phase; 47Hz~63Hz											
Power(Max.)		90VA			110VA			190VA			230VA		
Interface		Std : USB/RS232/Analog Control ; Opt : GPIB											
Dimensions & Weight		213.8(W)x124(H)x400.5(D)mm; Approx. 6kg			213.8(W)x124(H)x400.5(D)mm; Approx. 7kg			427.8(W)x124(H)x400.5(D)mm; Approx. 17kg			427.7(W)x127.8(H)x553.5(D)mm; Approx. 23kg		

Programmable D.C. Electronic Load

SPECIFICATIONS

Model	PEL-3212H	PEL-3323H	PEL-3424H	PEL-3535H	PEL-3322H	PEL-3533H	PEL-3744H	PEL-3955H		
Voltage	0V~800V	0V~800V	0V~800V	0V~800V	0V~800V	0V~800V	0V~800V	0V~800V		
Current	0~105A	0~157.5A	0~210A	0~262.5A	0~157.5A	0~262.5A	0~367.5A	0~472.5A		
Power	2100W	3150W	4200W	5250W	3150W	5250W	7350W	9450W		
Input Resistance	1.62MΩ	1.08MΩ	0.81MΩ	0.648MΩ	3.24MΩ	3.24MΩ	3.24MΩ	3.24MΩ		
Min. Operating Voltage(DC)(Typ.)	5V@105A 2.5V@52.5A	5V@157.5A 2.5V@78.75A	5V@210A 2.5V@105A	5V@262.5A 2.5V@131.25A	5V@157.5A 2.5V@78.75A	5V@262.5A 2.5V@131.25A	5V@367.5A 2.5V@183.75A	5V@472.5A 2.5V@236.25A		
CONSTANT CURRENT MODE										
Operating Range	H,M,L	0-105A 0-10.5A 0-1.05A	0-157.5A 0-15.75A 0-1.575A	0-210A 0-21A 0-2.1A	0-262.5A 0-26.25A 0-2.625A	0-157.5A 0-15.75A 0-1.575A	0-262.5A 0-26.25A 0-2.625A	0-367.5A 0-36.75A 0-3.675A	0-472.5A 0-47.25A 0-4.725A	
Accuracy of Setting	H,M,L	±(0.2% of set + 0.1% of f.s. ⁵) + Vin ² /3.24MΩ			±(1.2% of set + 1.1% of f.s. ⁵) + Vin ² /3.24MΩ ⁵					
Resolution	H,M,L	4mA 0.4mA 0.04mA	6mA 0.6mA 0.06mA	8mA 0.8mA 0.08mA	10mA 1mA 0.1mA	6mA 0.6mA 0.06mA	10mA 1mA 0.1mA	14mA 1.4mA 0.14mA	18mA 1.8mA 0.18mA	
CR MODE										
Operating Range⁴	Range	H	21S~360μS (47.619mΩ~ 2.778kΩ)	31.5S~540μS (31.746mΩ~ 1.85185kΩ)	42S~0.72mS (23.8095mΩ~ 1.3889kΩ)	52.5S~0.9mS (19.0476mΩ~ 1.11111kΩ)	31.5S~540μS (31.746mΩ~ 1.85185kΩ)	52.5S~0.9mS (19.0476mΩ~ 1.11111kΩ)	73.5S~1.26mS (13.6054mΩ~ 793.651Ω)	94.5S~1.26mS (10.582mΩ~ 617.284Ω)
		M	2.1S~36μS (476.19mΩ~ 27.778kΩ)	3.15S~540μS (317.46mΩ~ 18.5185kΩ)	4.2S~0.72mS (238.095mΩ~ 13.8889kΩ)	5.25S~0.9mS (190.476mΩ~ 11.1111kΩ)	3.15S~540μS (317.46mΩ~ 18.5185kΩ)	5.25S~0.9mS (190.476mΩ~ 11.1111kΩ)	7.35S~1.26μS (136.054mΩ~ 793651kΩ)	9.45S~1.26μS (105.82mΩ~ 617284kΩ)
		L	210mS~3.6μS (4.7619Ω~ 277.78kΩ)	315mS~540μS (3.1746Ω~ 185.185kΩ)	420mS~0.72mS (2.38095Ω~ 138.888kΩ)	525mS~0.9mS (1.90476Ω~ 111.111kΩ)	315mS~540μS (3.1746Ω~ 185.185kΩ)	525mS~0.9mS (1.90476Ω~ 111.111kΩ)	735mS~12.6μS (1.36054Ω~ 79.365kΩ)	945mS~162μS (1.0582Ω~ 61.7284kΩ)
Accuracy of Setting⁵	H,M,L	±(0.5% of set ⁶ + 0.5% of f.s. ⁵) + Vin ² /3.24MΩ : Alone operation specifications								
Resolution		360μS 36μS 3.6μS	540μS 54μS 5.4μS	720μS 72μS 7.2μS	900μS 90μS 9μS	540μS 54μS 5.4μS	900μS 90μS 9μS	1.26mS 126μS 12.6μS	1.62mS 162μS 16.2μS	
CONSTANT VOLTAGE MODE										
Operating Range	Range	H	5V~800V							
		L	5V~80V							
Accuracy of Setting⁷	Range	H,L	±(0.2% of set + 0.2% of f.s.)							
Resolution	Range	H,L	20mV/2mV							
CONSTANT POWER MODE										
Operating Range	Range	H	0W~2100W	0W~3150W	0W~4200W	0W~5250W	0W~3150W	0W~5250W	0W~7350W	0W~9450W
		M	0W~210W	0W~315W	0W~420W	0W~525W	0W~315W	0W~525W	0W~735W	0W~945W
		L	0W~21W	0W~31.5W	0W~42W	0W~52.5W	0W~31.5W	0W~52.5W	0W~73.5W	0W~94.5W
Accuracy of Setting⁸	H,M,L	±(0.6% of set + 1.4% of f.s. ⁵) + Vin x Vin ² /3.24MΩ : Alone operation specifications								
Resolution		200mW 20mW 2mW	300mW 30mW 3mW	400mW 40mW 4mW	500mW 50mW 5mW	300mW 30mW 3mW	500mW 50mW 5mW	700mW 70mW 7mW	900mW 90mW 9mW	
PARALLEL Mode										
Capacity		-								
SLEW RATE										
Operation Mode		CC, CR								
Setting Range (CC mode)	Range	H	1.68mA/μs~840mA/μs	2.52mA/μs~839.7mA/μs	3.36mA/μs~840mA/μs	4.2mA/μs~840mA/μs	2.52mA/μs~839.7mA/μs	4.2mA/μs~840mA/μs	5.88mA/μs~840mA/μs	7.56mA/μs~839.7mA/μs
		M	168μA/μs~84mA/μs	252μA/μs~83.97mA/μs	336μA/μs~84mA/μs	420μA/μs~84mA/μs	252μA/μs~83.97mA/μs	420μA/μs~84mA/μs	588μA/μs~84mA/μs	756μA/μs~83.97mA/μs
		L	16.8μA/μs~8.4mA/μs	25.2μA/μs~8.397mA/μs	33.6μA/μs~8.4mA/μs	42μA/μs~8.4mA/μs	25.2μA/μs~8.397mA/μs	42μA/μs~8.4mA/μs	58.8μA/μs~8.4mA/μs	75.6μA/μs~8.397mA/μs
Setting Range (CR Mode)	Range	H	168μA/μs~84mA/μs	252μA/μs~83.97mA/μs	336μA/μs~84mA/μs	420μA/μs~84mA/μs	252μA/μs~83.97mA/μs	420μA/μs~84mA/μs	588μA/μs~84mA/μs	756μA/μs~83.97mA/μs
		M	16.8μA/μs~8.4mA/μs	25.2μA/μs~8.397mA/μs	33.6μA/μs~8.4mA/μs	42μA/μs~8.4mA/μs	25.2μA/μs~8.397mA/μs	42μA/μs~8.4mA/μs	58.8μA/μs~8.4mA/μs	75.6μA/μs~8.397mA/μs
		L	1.68μA/μs~840μA/μs	2.52μA/μs~839.7μA/μs	3.36μA/μs~840μA/μs	4.2μA/μs~840μA/μs	2.52μA/μs~839.7μA/μs	4.2μA/μs~840μA/μs	5.88μA/μs~840μA/μs	7.56μA/μs~839.7μA/μs
Accuracy of Setting⁹	H,M,L	±(1.0% of set + 25μs)								
Resolution		600μA(168mA~840mA/μs) 60μA(16.8mA~84mA/μs) 6μA(1.68mA~8.4mA/μs) 600nA(0.1680mA~8.4mA/μs) 60nA(0.01680mA~8.4mA/μs) 6nA(0.00168mA~8.4mA/μs)	900μA(252mA~839.7mA/μs) 90μA(25.2mA~83.97mA/μs) 9μA(2.52mA~8.397mA/μs) 900nA(252nA~83.97mA/μs) 90nA(25.2μA~8.397mA/μs) 9nA(2.52μA~8.397mA/μs)	1.2mA(336mA~840mA/μs) 120μA(33.6mA~84mA/μs) 12μA(3.36mA~8.4mA/μs) 1.2mA(336μA~84mA/μs) 120nA(33.6μA~8.4mA/μs) 12nA(3.36μA~8.4mA/μs)	1.5mA(420mA~840mA/μs) 150μA(42mA~84mA/μs) 15μA(4.2mA~8.4mA/μs) 1.5mA(420μA~84mA/μs) 150nA(42μA~8.4mA/μs) 15nA(4.2μA~8.4mA/μs)	900μA(252mA~839.7mA/μs) 90μA(25.2mA~83.97mA/μs) 9μA(2.52mA~8.397mA/μs) 900nA(252nA~83.97mA/μs) 90nA(25.2μA~8.397mA/μs) 9nA(2.52μA~8.397mA/μs)	1.5mA(420mA~840mA/μs) 150μA(42mA~84mA/μs) 15μA(4.2mA~8.4mA/μs) 1.5μA(420μA~84mA/μs) 150nA(42μA~8.4mA/μs) 15nA(4.2μA~8.4mA/μs)	2.1mA(588mA~840mA/μs) 210μA(58.8mA~84mA/μs) 21μA(5.88mA~8.4mA/μs) 2.1mA(588μA~84mA/μs) 210nA(58.8μA~8.4mA/μs) 21nA(5.88μA~8.4mA/μs)	2.7mA(756mA~839.7mA/μs) 270μA(75.6mA~83.97mA/μs) 27μA(7.56mA~8.397mA/μs) 2.7μA(756μA~83.97mA/μs) 270nA(75.6μA~8.397mA/μs) 27nA(7.56μA~8.397mA/μs)	
METER										
Voltmeter Accuracy		±(0.1% of rdg + 0.1% of f.s.)								
Ammeter Accuracy		±(1.2% of rdg + 1.1% of f.s.)								
DYNAMIC MODE										
Operation Mode		CC and CR								
T1 & T2 Accuracy		0.025ms~10ms/Res : 1μs ; 10ms~30S/Res : 1ms 1μS/1ms ± 100ppm								
Slew Rate (CC Mode)	Range	H	1.68mA/μs~840mA/μs	2.52mA/μs~839.7mA/μs	3.36mA/μs~840mA/μs	4.2mA/μs~840mA/μs	2.52mA/μs~839.7mA/μs	4.2mA/μs~840mA/μs	5.88mA/μs~840mA/μs	7.56mA/μs~839.7mA/μs
		M	168μA/μs~84mA/μs	252μA/μs~83.97mA/μs	336μA/μs~84mA/μs	420μA/μs~84mA/μs	252μA/μs~83.97mA/μs	420μA/μs~84mA/μs	588μA/μs~84mA/μs	756μA/μs~83.97mA/μs
		L	16.8μA/μs~8.4mA/μs	25.2μA/μs~8.397mA/μs	33.6μA/μs~8.4mA/μs	42μA/μs~8.4mA/μs	25.2μA/μs~8.397mA/μs	42μA/μs~8.4mA/μs	58.8μA/μs~8.4mA/μs	75.6μA/μs~8.397mA/μs
Slew Rate (CR Mode)	Range	H	168μA/μs~84mA/μs	252μA/μs~83.97mA/μs	336μA/μs~84mA/μs	420μA/μs~84mA/μs	252μA/μs~83.97mA/μs	420μA/μs~84mA/μs	588μA/μs~84mA/μs	756μA/μs~83.97mA/μs
		M	16.8μA/μs~8.4mA/μs	25.2μA/μs~8.397mA/μs	33.6μA/μs~8.4mA/μs	42μA/μs~8.4mA/μs	25.2μA/μs~8.397mA/μs	42μA/μs~8.4mA/μs	58.8μA/μs~8.4mA/μs	75.6μA/μs~8.397mA/μs
		L	1.68μA/μs~840μA/μs	2.52μA/μs~839.7μA/μs	3.36μA/μs~840μA/μs	4.2μA/μs~840μA/μs	2.52μA/μs~839.7μA/μs	4.2μA/μs~840μA/μs	5.88μA/μs~840μA/μs	7.56μA/μs~839.7μA/μs
Current Accuracy		±0.4%F.S.								
PROTECTION FUNCTION										
Functions		Overvoltage protection(OVP), Overcurrent protection(OCP), Overpower protection(OPP), Overheat protection(OHP), Undervoltage protection(UVP), Reverse connection protection(REV)								
GENERAL										
Input Range		90VAC~132VAC/180VAC~250VAC Single-phase; 47Hz~63Hz								
Power(Max.)		380VA	570VA	760VA	950VA	420VA	650VA	880VA	1110VA	
Interface		Std : USB/RS232/Analog Control ; Opt. : GPIB								
Dimensions & Weight		598(W)x877(H)x706(D)mm; Approx. 67.5kg	598(W)x877(H)x706(D)mm; Approx. 85.5kg	598(W)x877(H)x706(D)mm; Approx. 110kg	598(W)x877(H)x706(D)mm; Approx. 127.5kg	598(W)x877(H)x706(D)mm; Approx. 73kg	598(W)x877(H)x706(D)mm; Approx. 96.5kg	598(W)x877(H)x706(D)mm; Approx. 125kg	598(W)x877(H)x706(D)mm; Approx. 149kg	

PEL-3000/3000(H) Series

ELECTRONIC LOAD

ORDERING INFORMATION

PEL-3021 (150V/35A/175W) Single-Channel Programmable D.C. Electronic Load
PEL-3041 (150V/70A/350W) Single-Channel Programmable D.C. Electronic Load
PEL-3111 (150V/210A/1050W) Single-Channel Programmable D.C. Electronic Load
PEL-3211 (150V/420A/2100W) Single-Channel Programmable D.C. Electronic Load
PEL-3212 (150V/420A/2100W) Single-Channel Programmable D.C. Electronic Load
PEL-3322 (150V/630A/3150W) Single-Channel Programmable D.C. Electronic Load
PEL-3323 (150V/630A/3150W) Single-Channel Programmable D.C. Electronic Load
PEL-3424 (150V/840A/4200W) Single-Channel Programmable D.C. Electronic Load
PEL-3533 (150V/1050A/5250W) Single-Channel Programmable D.C. Electronic Load
PEL-3535 (150V/1050A/5250W) Single-Channel Programmable D.C. Electronic Load
PEL-3744 (150V/1470A/7350W) Single-Channel Programmable D.C. Electronic Load
PEL-3955 (150V/1890A/9450W) Single-Channel Programmable D.C. Electronic Load

PEL-3021H (800V/8.75A/175W) Single-Channel Programmable D.C. Electronic Load
PEL-3041H (800V/17.5A/350W) Single-Channel Programmable D.C. Electronic Load
PEL-3111H (800V/52.5A/1050W) Single-Channel Programmable D.C. Electronic Load
PEL-3211H (800V/105A/2100W) Single-Channel Programmable D.C. Electronic Load
PEL-3212H (800V/105A/2100W) Single-Channel Programmable D.C. Electronic Load
PEL-3322H (800V/157.5A/3150W) Single-Channel Programmable D.C. Electronic Load
PEL-3323H (800V/157.5A/3150W) Single-Channel Programmable D.C. Electronic Load
PEL-3424H (800V/210A/4200W) Single-Channel Programmable D.C. Electronic Load
PEL-3533H (800V/262.5A/5250W) Single-Channel Programmable D.C. Electronic Load
PEL-3535H (800V/262.5A/5250W) Single-Channel Programmable D.C. Electronic Load
PEL-3744H (800V/367.5A/7350W) Single-Channel Programmable D.C. Electronic Load
PEL-3955H (800V/472.5A/9450W) Single-Channel Programmable D.C. Electronic Load

ACCESSORIES :

Quick Start Guide, CD(User Manual/Programming Manual), Power Cord
PEL-011 Load Input Terminal Cover **PEL-012** Terminal Fittings Kits

GTL-255 Frame Link Cable 300mm
PEL-013 Flexible Terminal Cover

Front Terminal Washers
PEL-014 J1/J2 Protection Plug

OPTIONAL ASSESSORIES

CR123A 3V Lithium Battery for Clock.

GRA-413 Rack Mount Bracket for Booster PEL-3211(H) (EIA+JIS)

GRA-414-E Rack Mount Frame for PEL-3021(H), PEL-3041(H), PEL-3111(H)/EIA

GRA-414-J Rack Mount Frame for PEL-3021(H), PEL-3041(H), PEL-3111(H)/JIS

GTL-120 Test Lead (Max. 40A)

GTL-248 GPIB Cable, 2.0m

GTL-246 USB Cable Type A- Type B

PEL-010 Dust Filter

PEL-004 GPIB Option

PEL-005 Connect Cu Plate

PEL-006 Connect Cu Plate

PEL-007 Connect Cu Plate

PEL-008 Connect Cu Plate

PEL-009 Connect Cu Plate

FREE DOWNLOAD

Driver LabView Driver

PEL-005 Connect Cu Plate **PEL-006** Connect Cu Plate **PEL-007** Connect Cu Plate **PEL-008** Connect Cu Plate **PEL-009** Connect Cu Plate **GTL-120** Test Lead



PEL-011 Load Input Terminal Cover **PEL-012** Terminal Fittings Kits **PEL-013** Flexible Terminal Cover **PEL-014** J1/J2 Protection Plug **GTL-255** Frame Link Cable



PEL-3322(H) **PEL-3533(H)** **PEL-3744(H)** **PEL-3955(H)**

GRA-413 Rack Mount Kit (EIA+JIS)

For : PEL-3211(H)



GRA-414-J Rack Mount Kit (JIS)

For : PEL-3021(H)/3041(H)/3111(H)



GRA-414-E Rack Mount Kit (EIA)

For : PEL-3021(H)/3041(H)/3111(H)



PEL-3212(H) **PEL-3323(H)** **PEL-3424(H)** **PEL-3535(H)**

Programmable D.C. Electronic Load



PEL-3031E



PEL-3032E



FEATURES

- * 0-150V(PEL-3031E) Min. Operating Voltage(dc) : 1V at 60A, 0.5V at 30A
- * 0-500V(PEL-3032E) Min. Operating Voltage(dc) : 2.5V at 15A, 1.25V at 7.5A
- * 7 Operating Modes : CC, CV, CR, CP, CC+CV, CR+CV, CP+CV
- * Normal Sequence Function: Max Steps: 1000 steps/Step Time:1ms-999h 59min 59s(3599940 sec)Fast Sequence Function: Max Steps:1000 steps/Step Time:25us-600ms
- * Soft Start
- * BATT Test Automation:Max Test Time:999h: 59min 59s(3599940 sec):Max Test AH:9999.99Ah
- * OCP, OPP Test Automation
- * Max. Slew Rate : 2.5A/ μ s
- * Dynamic Mode
- * Protection : OVP, OCP, OPP, OTP, RVP, UVP
- * Remote Sense
- * Integrate Voltage, Current and Power Measurement Functions
- * External Voltage or Resistance Control
- * Rear Panel BNC, Trigger IN/OUT
- * Analog External Control
- * USB/GPIB(Optional)

CW Instek launches new PEL-3000E series programmable single-channel electronic load. In the series, PEL-3031E provides 300W (1V-150V/60A) and PEL-3032E provides 300W (2.5V-500V/15A) current sink capability. Inherited from the PEL-3000 series, PEL-3000E has an easy-to-read LCD panel and user-friendly interface. This model features high speed and accurate measurement capability for electronic component, battery, portable charger and power products that require low to medium power consumption.

The PEL-3000E series is designed for current sink operation starting from 60mA and aims at measurement applications, including charger, adapter, various power supply equipment, and portable charger.

The PEL-3000E has seven operating modes. Among them, four basic operating modes are constant current, constant voltage, constant resistance, and constant power. Three other combined operating modes are constant current + constant voltage, constant resistance + constant voltage, constant power + constant voltage. Users can select operating modes based upon products' test requirements. For C.C. mode, electronic load will sink a constant current according to the set current value; for C.V. mode, electronic load will attempt to sink sufficient current to control the source voltage to the programmed value; for C.R. mode, electronic load will sink a current linearly proportional to input voltage according to the set resistance value; for C.P. mode, electronic load will initiate load power sinking operation (load voltage x load current) in accordance with the programmed power setting.

To meet the requirements of different test conditions, the Static function is to sink a constant current; the Dynamic function is to periodically switch between two sink conditions, and the Sequence function is to provide tests for more than two sink conditions. The sequence function can be divided into Normal Sequence and Fast Sequence. Normal Sequence is the most flexible mean of generating complex sequences that can facilitate users to establish a set of changing current sink conditions based upon different sinking conditions (CC, CR, CV or CP mode) and time (adjustable range: 1ms to 999h 59min 59s). Fast sequence allows time resolution of 25us to be set for the smallest step. Setting parameters for multiple steps can simulate consecutive current changes of various real load conditions. For instance, while using an electronic load to test a power-driven tool's power supply, we can first obtain waveforms by an oscilloscope and a current probe from the tool, and subsequently, use the obtained waveforms to edit simulated current waveforms, via electronic load's sequence function, to test the power-driven tool and to analyze its operational status. The Soft Start function allows users to determine the rise time of current sink that is to decide the required time to reach electronic load's set current, resistance or power value. Setting a proper rise time for Soft Start is effective to counter output voltage fluctuation caused by DUT's (power supply) transient output current. It is worth noting, General DC loads do not have the soft start function. When conducting high speed current sink operation, the inductance effect on the cable connecting electronic load and DUT will lead to transient voltage drop on electronic load's input terminal, therefore, that will result in Voltage Non-monotonic increase. PEL-3000E's soft start function not only allows output voltage to be Monotonic increase, but also prevents inrush current and surge voltage from happening on DUT. For instance, tests using a power supply, LED and a DC load (activate the soft start function) can prevent inrush current and surge voltage from causing damages on LED.

The built-in BATT Test Automation of PEL-3000E provides battery discharge applications with more flexible discharge stop setting as well as rise and fall Slew Rate for discharge current settings. OCP, OPP test Automation for DUT (ex. Power Supply), provide users with high resolution measurement values to verify DUT's activation point. Provide users with measurement results so as to help them determine whether DUT's actual over protection activation point meets the regulations. Other than that, PEL-3000E provides users with analog control terminal to control PEL-3000E from external voltage, external resistance and switch. Analog control terminal can also monitor electronic load's status and display protective alarms.

SPECIFICATIONS				
Model	PEL-3031E		PEL-3032E	
	Power Range	300W Low	300W High	300W Low
Voltage	0 - 150V	0 - 150V	0 - 500V	0 - 500V
Current	0 - 6A	0 - 60A	0 - 1.5A	0 - 15A
Min. Operating Voltage(dc)	1V - 6A	1V - 60A	2.5V - 1.5A	2.5V - 15A
STATIC MODE				
Constant Current Mode Range	0 - 6A	0 - 60A	0 - 1.5A	0 - 15A
	0 - 6.12A	0 - 61.2A	0 - 1.53A	0 - 15.3A
Setting Range	0.2mA	2mA	0.05mA	0.5mA
	(T [±])±(0.1% of set +0.1% of FS)+ Vin/500k Ω	(T [±])±(0.1% of set +0.2% of FS)+ Vin/500k Ω	(T [±])±(0.1% of set +0.1% of FS)+ Vin/500k Ω	(T [±])±(0.1% of set +0.2% of FS)+ Vin/500k Ω
Resolution (30000 Steps)	0.002s (15V) ; 0.0002s (150V)	0.002s (15V) ; 0.0002s (150V)	0.0002s (50V) ; 0.00002s (500V)	0.0002s (50V) ; 0.00002s (500V)
	(T [±])±(0.3% of set + 0.6s) + 0.002ms	(T [±])±(0.3% of set + 0.6s) + 0.002ms	(T [±])±(0.3% of set + 0.06s) + 0.002ms	(T [±])±(0.3% of set + 0.06s) + 0.002ms
Constant Voltage Mode Range	1 - 15V	1 - 150V	2.5 - 50V	2.5 - 500V
	0 - 15.3V	0 - 153V	0 - 51V	0 - 510V
Setting Range	0.5mV	5mV	1mV	10mV
	(T [±])±(0.1% of set+ 0.1% of FS) (Full scale of Low range)	(T [±])±(0.1% of set+ 0.1% of FS) (Full scale of High range)	(T [±])±(0.1% of set+ 0.1% of FS) (Full scale of Low range)	(T [±])±(0.1% of set+ 0.1% of FS) (Full scale of High range)
Constant Power Mode Range	0W - 30W (6A)	0W - 300W (60A)	0W - 30W (1.5A)	0W - 300W (15A)
	0W - 30.6W	0W - 306W	0W - 30.6W	0W - 306W
Resolution	1mW	10mW	1mW	10mW
Accuracy	(T [±])±(0.6 % of set + 1.4 % of FS (Full scale of H range) + Vin \wedge 2/500 k Ω)			



PEL-3032E

Rear Panel



SPECIFICATIONS				
Model	PEL-3031E		PEL-3032E	
DYNAMIC MODE				
General	0.05ms~30ms/Res:1μs;30ms~30s/Res:1ms		0.05ms~30ms/Res:1μs;30ms~30s/Res:1ms	
TI & T2	1μs/1ms±200ppm		1μs/1ms±200ppm	
Accuracy	1μs/1ms±200ppm		1μs/1ms±200ppm	
Slew Rate(Accuracy 10%)	0.001 ~ 0.25A/μs		0.25 ~ 62.5mA/μs	
Slew Rate Resolution	0.001A/μs		0.25mA/μs	
Slew Rate Accuracy of Setting	±(1.0% + 15μs) *1 Time to reach from 10 % to 90 % when the current is varied from 2 % to 100 % (20 % to 100 % in L range) of the rated current.			
Constant Current Mode				
Current	0 ~ 6A	0 ~ 60A	0 ~ 1.5A	0 ~ 15A
Setting Range	0 ~ 6.12A	0 ~ 61.2A	0 ~ 1.53A	0 ~ 15.3A
Current Resolution	0.2mA	2mA	0.05mA	0.5mA
Current Accuracy	±0.8% FS		±0.8% FS	
Constant Resistance Mode				
Range	60s~0.002s(0.01666Ω~500Ω)(300W/15V)		6s~0.0002s(0.16666Ω~5kΩ)(300W/50V)	
Setting Range	6s~0.0002s(0.1666Ω~5kΩ)(300W/150V)		0.6s~0.00002s(1.6666Ω~50kΩ)(300W/500V)	
Resistance Resolution	60s~0.002s(0.01666Ω~500Ω)(300W/15V)		6s~0.0002s(0.16666Ω~5kΩ)(300W/50V)	
Resistance Accuracy	30000 steps		30000 steps	
	(T [°])±(1%set + 0.6s) + 0.002ms		(T [°])±(1%set + 0.06s) + 0.002ms	
MEASUREMENT				
Voltage Readback	0 ~ 15V	0 ~ 150V	0 ~ 50V	0 ~ 500V
Range	0.5mV	5mV	2mV	20mV
Resolution	(T [°])±(0.1% of rdg + 0.1% of FS)			
Accuracy	(Full scale of Low range)			
Current Readback	0 ~ 6A	0 ~ 60A	0 ~ 1.5A	0 ~ 15A
Range	0.2mA	2mA	0.05mA	0.5mA
Resolution	(T [°])±(0.1% of rdg + 0.1% of FS)			
Accuracy	(Full scale of High range)			
Power Read back H&L Range	0 ~ 300W	0 ~ 300W	0 ~ 300W	0 ~ 300W
CP Mode L Range	0 ~ 30W	0 ~ 30W	0 ~ 30W	0 ~ 30W
FUNCTION				
Sequence(Normal/Fast)	Normal sequence function: Max steps: 1000 steps/Step time: 1ms ~ 999h 59min 59s(3599940 sec)			
	Fast sequence function: Max steps: 1000 steps/Step time: 25us ~ 600ms			
BATT Test Automation	Max test time: 999h: 59m: 59s(3599940sec)			
	Max test AH: 9999.99Ah			
Test Function	OCP Autotest function, OPP Autotest Function			
Soft Start	Yes			
In/Out Terminal	Analog External Control, Current Monitor Output, Trigger In/Out Terminal(BNC)			
Preset Data	10 Sets			
Protection	OCP, OPP, UVP, OVP, OTP, RVP			
OTHER				
Power Source	100 ~ 120VAC/ 200 ~ 240VAC, 47 ~ 63Hz			
Interface	USB, GPIB(Optional), Analog control			
Dimensions & Weight	213.8(W) x 124.0(H) x 400.5(D)mm, Approx. 7.5Kg			

Note : *1 - If the ambient temperature is over 30 °C or below 20 °C, then T = ± |t - 25 °C| x 100ppm/°C x Set
If the ambient temperature is in the range of 20°C~30°C, then T = 0 (t is the ambient temperature)

ORDERING INFORMATION

PEL-3031E 150V/60A/300W Programmable Single-channel D.C. Electronic Load
PEL-3032E 500V/15A/300W Programmable Single-channel D.C. Electronic Load

ACCESSORIES :

Quick Start Guide, CD ROM (User Manual, Programming Manual)x1, Power Cord (Region dependent), Front Terminal Washers-spring Washer(M6)x2, GTL-105A Remote Sense Cables(Red x 1, Black x 1)

OPTIONAL ACCESSORIES

GTL-248 GPIB Cable, 2m	PEL-010 Dust Filter	GRA-414-J Rack Mount Kit (JIS)
GTL-246 USB Cable, Type A – Type B	PEL-004 GPIB Option	GRA-414-E Rack Mount Kit (EIA)
GTL-251 USB-GPIB Adapter, GPIB-USB-HS (High Speed)		

GRA-414-J Rack Mount Kit (JIS)

For : PEL-3021(H)/3041(H)/3111(H)



GRA-414-E Rack Mount Kit (EIA)

For : PEL-3021(H)/3041(H)/3111(H)



Programmable D.C. Electronic Load

A. OPERATING MODE

The PEL-3000E series provides four fundamental operating modes and three add-on modes of CC, CR and CP separately combining with CV. Users can set different load condition under different operating modes such as setting operating range for load level, Current Slew Rate, input voltage and load current. The input

voltage range has two levels - high and low. The load current operating range has two levels - high and low current levels which possess different resolution to meet test requirements of different power product specifications.

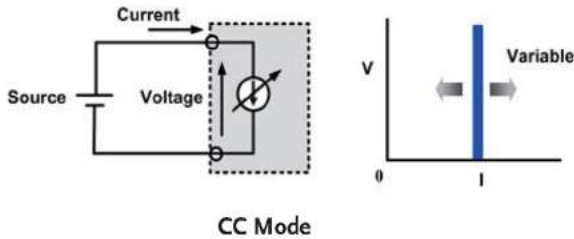

Under constant current mode, electronic load will sink the amount of current users has set. Different current settings via CC mode allow users to test the voltage changes of DC power supply which is called load regulation test.

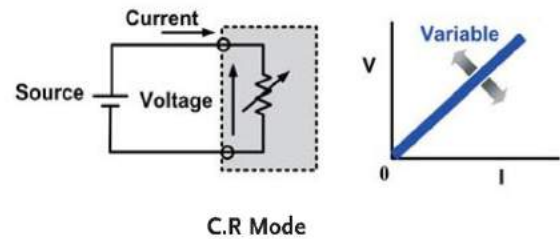

Under constant resistance mode, electronic load will sink load current, which is linearly direct proportion to input voltage. This mode can be utilized in testing voltage or the activation and current limit of power supply.

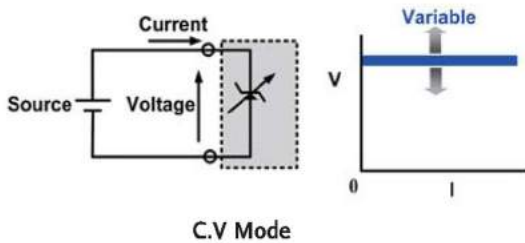

Under constant voltage mode, electronic load will sink sufficient current to regulate the voltage source to the set value. This mode allows users not only to test current limit function of power supply, but also to simulate battery operation in testing battery chargers.

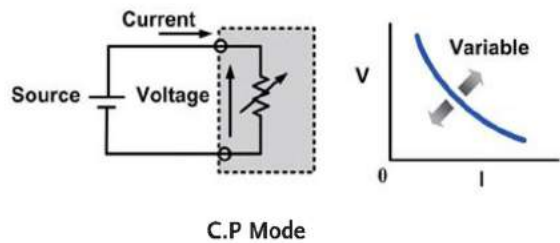

Under constant power mode, electronic load will sink load current, which is indirect proportion to input voltage to reach preset constant power requirement. Hence, the changes of input voltage will have indirect proportion effect on current sinking so as to reach constant power control.

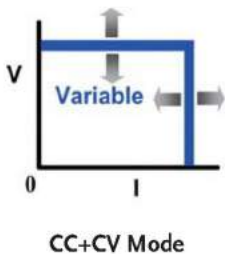

+CV mode can be selected under CC, CR or CP mode. When +CV mode function is turned on and electronic load sinks more current than the maximum current of power supply under test, electronic load will automatically switch to CV mode. It is because that the current sunk is the maximum current of power device. Therefore,

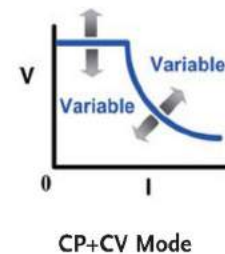
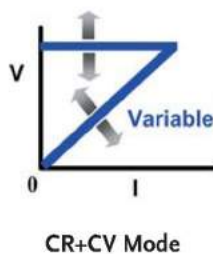

power supply will switch to CC mode and PEL-3000 will switch to CV mode to limit electronic load from sinking the total current of power supply so as to prevent power supply under test from damaging. Electronic load will cease operation once the voltage of DUT is lower than the set voltage under +CV mode.

B. STATIC/DYNAMIC/SEQUENCE MODE

Function / Operation	Static	Dynamic	Sequence	
			Fast	Normal
Operating Condition Selection	Single fixed condition	Selection between two conditions	Selection from more than two conditions	Selection from more than two conditions
Operating Modes	All modes	<ul style="list-style-type: none"> Two conditions using same mode Support CC or CR 	<ul style="list-style-type: none"> Each condition must use same mode Support CC or CR mode 	<ul style="list-style-type: none"> Each condition is able to be used in different mode All modes
Adjustable Condition Setting	<ul style="list-style-type: none"> Value A/ Value B Slew Rate 	<ul style="list-style-type: none"> Level 1/Level 2 Timer 1/Timer 2 Slew Rate 1/Slew Rate 2 	<ul style="list-style-type: none"> Level Timer Slew Rate Others... 	<ul style="list-style-type: none"> Level Timer Slew Rate Others...
Sequence Step Combination	N/A	N/A	<ul style="list-style-type: none"> 1 Sequence 1,000 steps 25µs/step 	<ul style="list-style-type: none"> 10 Sequence 1,000 steps 1ms/step
Other Functions	N/A	Trigger Out function	Trigger Out function	<ul style="list-style-type: none"> Trigger Out function Ramp function

The PEL-3000E series, according to different test conditions, step or continuous changes, test speeds, and selectable modes, has three operating functions: Static, Dynamic and Sequence.

C. FAST SEQUENCE & NORMAL SEQUENCE

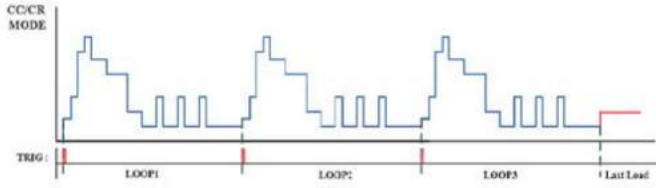

Fast Sequence Diagram

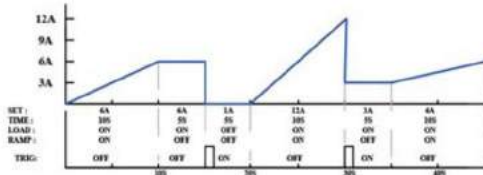

Normal Sequence Diagram

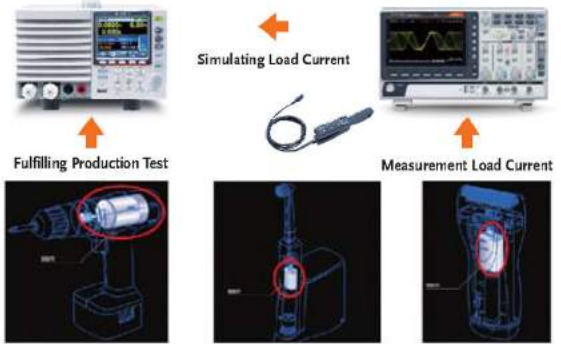

Power-driven Tools Simulation Test

Set a complete sequence editing function to obtain following waveforms. Users can save development cost and time without using a PC to control electronic load and writing programs.



When operating the Sequence Function, PEL-3000E Series follows the time and load settings of step1, step2, step3, etc. so as to realize different load current variation.

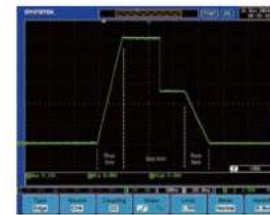

Ramp function of PEL-3000E Series is able to set the current transition. When turned on, the current takes on a slope form; when turned off, the current takes on a step form.

D. SOFT START

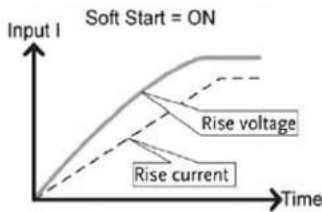

The Soft Start function of PEL-3000E Series allows users to determine the rise time of current sink that is to decide how much time is required to reach electronic load's set current, resistance or power value. PEL-3000E's soft start function prevents inrush current and surge voltage from happening on DUT.

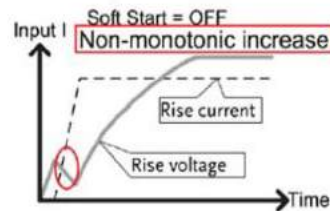

For instance, test applications using a power supply, LED and a DC load (activate the soft start function) can prevent inrush current and surge voltage from causing damages on LED.

E. BATT TEST AUTOMATION

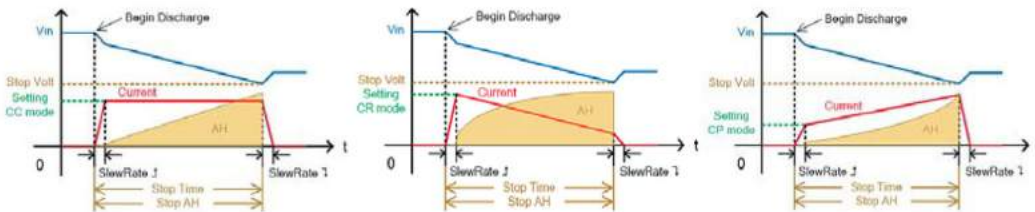

CC Mode

CR Mode

CP Mode



BATT Test Automation Editing

The built-in BATT Test Automation of PEL-3000E provides battery discharge applications with more flexible discharge stop condition setting as well as rise and fall Slew Rate for discharge current settings. Under CP, CC or CR mode, the

conditions for stop discharge can be set respectively. For instance, set the input voltage for stop discharge current, the execution time for discharge current or total discharge current*time(AH) to satisfy the verification of battery capability.

Programmable D.C. Electronic Load

F. OCP TEST AUTOMATION

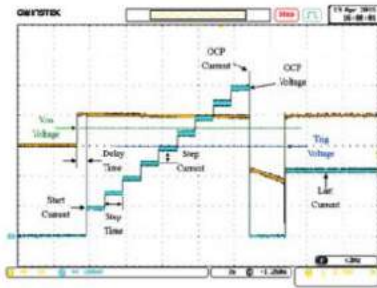

OCP test Automation for DUT (Power Supply), Provide users with high resolution OCP measurement values to verify DUT's OCP activation point. Provide users with measurement results so as to help them determine whether DUT's actual OCP activation point meets the regulations. Test the value of OCP by setting load current increment from start current to stop current. OCP's activation point can be accurately measured.

G. OPP TEST AUTOMATION

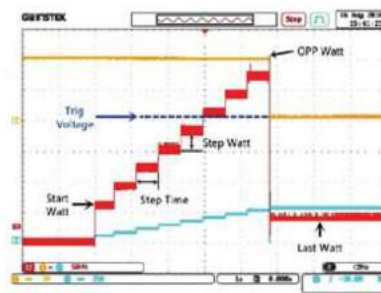

OPP test Automation for DUT (Power Supply), Provide users with high resolution OPP measurement values to verify DUT's OPP activation point. Provide users with measurement results so as to help them determine whether DUT's actual OPP activation point meets the regulations. Test the value of OPP by setting power increment from start power to stop power. OPP's activation point can be accurately measured.

H. TRIGGER IN/OUT BNC

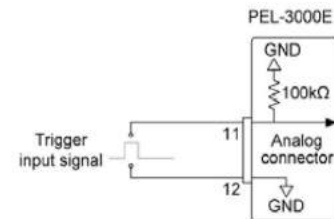
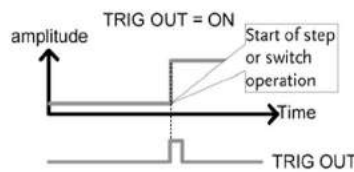

Trigger In/Out function could be turned on or off by CONFIGURE setting of PEL-3000E. The Trigger Input can be set the delay time while the Trigger Out Pulse Width can be set as well.

The trigger output signal is generated every time a switching operation is performed such as Dynamic mode or Fast/Normal sequence is executed when the trig out parameter is enabled. The trigger output signal from TRIG OUT BNC is a 4.5V pulse of at least 2us with an impedance of 50ohm. The common

potential is connected to the chassis potential. The signal threshold level is TTL.

The TRIG IN BNC on the rear panel is used to resume a sequence after a pause. This action is useful to synchronize the execution of a sequence with another device. To resume a pause sequence, apply a high signal for 10us or more. The TRIG IN BNC is pulled down to earth internally using a 100Kohm resistor.

I. PROTECTION MODES

Function \ Protection	OCP	OVP	OPP	OTP	UVP
Adjustable Thresholds	✓	✓	✓	N/A	✓
Load Off	✓	✓	✓	Fixed	✓
Limit Function	✓	N/A	✓	N/A	N/A

The PEL-3000E series provides many protective functions including over current protection (OCP), over voltage protection (OVP), over power protection (OPP), over temperature protection (OTP) and under voltage protection (UVP). Except for OTP, all thresholds

of protective functions are adjustable. When protective function is activated, electronic load will send out warning signal and terminate operation. Other than protective functions, Limit function can also be utilized to maintain electronic load in operation at a preset value.

J. ANALOG EXTERNAL CONTROL

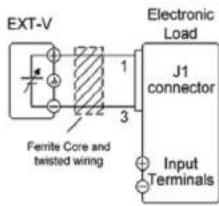

External Voltage Control

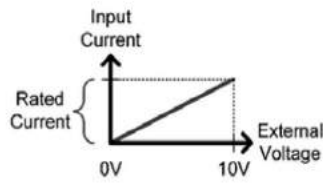

CC Mode

$$\text{Input current} = \text{rated current} \times (\text{external voltage}/10)$$

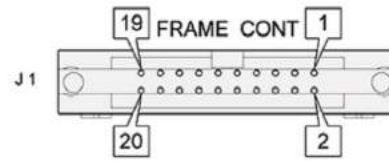

J1 Connector

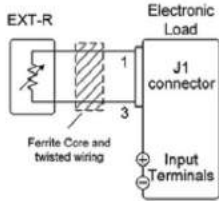

External Resistance Control

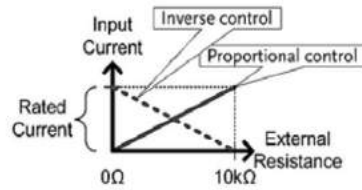

CC Mode

$$\text{Proportional Control: Input current} = \text{rated current} \times (\text{external resistance}/10\text{K ohm})$$

$$\text{Inverse Control: Input current} = \text{rated current} \times (1 - \text{external resistance}/10\text{k ohm})$$

The PEL-3000E series provides the external analog channel control function, which allows users to connect J1 connectors on the rear panel to input voltage or to connect resistance to control electronic load operation. Users can integrate this function into test system and utilize signals generated from the test system to control PEL-3000E.

K. VonN VOLTAGE AND Von LATCH FUNCTION

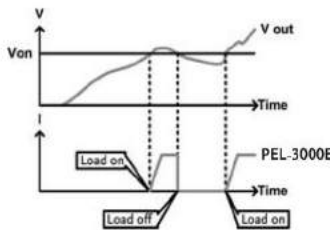

Von Latch = OFF

Von Voltage is the threshold voltage for electronic load to activate or terminate sinking current. When Von Latch is set to off, electronic load operation will be activated if input voltage is higher than Von Voltage and electronic load operation will be terminated if input voltage is lower than Von Voltage. When Von

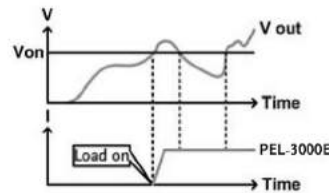

Von Latch = ON

Latch is set to on, electronic load operation will be activated if input voltage is higher than Von Voltage and will continue operation even input voltage is lower than Von Voltage. Von Voltage function can test the transient maximum current capability provided by power supply.

L. TIMER FUNCTIONS



Elapsed Time

The PEL-3000E series provides count time and cut off time functions. The display screen will show present activation time when electronic load is activated. When electronic load operation is terminated count time will stop and the total operation time will be shown on the display screen. The activation time of cut off time can be set to the maximum length of 999h 59min 59s. When electronic load is activated

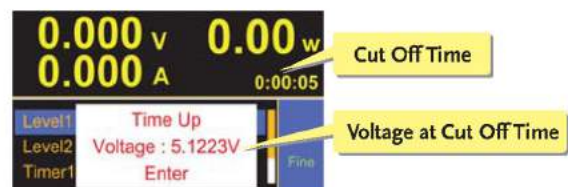

Voltage at Cut Off Time

this function will start counting time. Electronic load will cease operation (load off) and show the final input voltage on the screen when preset time is reached. Timer function can provides information and application related to time. Users can obtain the total time of limiting electronic load operation to increase the agility of electronic load tests.

Programmable D.C. Electronic Load



PEL-2004A



PEL-2002A



FEATURES

- * Sequence Function to do High Speed Load Simulations
- * Flexible Configuration with Mainframes and Plug-in Modules
- * Multiple Independent Load Inputs up to 8 Channels in a Mainframe
- * Parallel Connection of Inputs for Higher Load Capacity
- * Program Mode to Create Work Routines for Repetitive Tests
- * OPP/OCP/OVP/OTP/RVP/UVP Protections
- * External Channel Control/Monitoring via Analog Control Connector
- * Multiple-Interface USB Device/Host, RS-232C, and GPIB (Optional)

The PEL-2004A and PEL-2002A are multiple channel, programmable DC electronic loads with a modularized structure. The PEL-2000A Series is designed to meet the continuing shift toward high speed operation in today's semiconductor market. As the power supply units, DC-DC converters, and batteries that drive semiconductor circuits need to follow this shift, power supply design, quality inspection and characteristic certification using high-speed performance loads have become necessary. The PEL-2000A Series includes two types of mainframes and 4 types of load modules to accommodate users' requirements in a flexible manner. Any load module combination can be used with a mainframe to tailor a test system based on the number of channels, and the maximum load power, voltage and current of each channel. Multiple loads can be connected in parallel to provide a higher-power load to test higher power supply outputs. This flexibility significantly reduces the investment needed for future projects that have differed power requirements. PEL-2004A is a 4-slot mainframe with a master control unit to hold 4 load modules, while PEL-2002A is a 2-slot mainframe with master control unit to hold 2 load modules. When PEL-2004A is configured with 4 load modules rated at 350W each, the PEL-2000A series is able to sink up to 1.4kVA of power. For higher load capacities, mainframes can be linked together in parallel with standard MIL 20-pin connectors. A maximum of 5 mainframes, including one master and 4 slaves can be chained together to create a total load capacity of 7kW for high current and high power applications. Using 4 dual channel load modules, PEL-2004A is able to test 8 power supply outputs simultaneously. The Sequence function allows each channel to change its load sink according to a predefined sequence at a rate of up to 100 s per step. Each sequence is able to run concurrently, under the control of one clock. This is one of the most powerful features of the PEL-2000A Series as it is able to realistically simulate a multi-output power supply load. Under Dynamic mode, the load current or load resistance pulses between two preset levels at a pre-defined speed up to 25 s per step. This is often used as the standard test procedure to verify the response of a power supply to quick load changes. Most remarkably, multiple load channels can be connected in parallel to run Dynamic tests synchronously under a single clock. This Parallel Dynamic functionality gives the flexibility to perform dynamic tests for a high-power power supply without the need of another high-power load. The PEL-2000A Series includes a number of protection modes: Over Current Protection (OCP), Over Voltage Protection (OVP), Over Power Protection (OPP), Reverse Voltage Protection (RVP), and Under Voltage Protection (UVP). The protection modes are useful to protect both the load modules and the DUT(s). A buzzer can be set for when a protection setting has been tripped. When a protection mode has been tripped, the load unit will display an alarm and stop sinking current/voltage. When a load unit is operating in CR or CV mode, the unit may need Over Current Protection to prevent excessive current being sunk. Over Current Protection stops the load from sinking more current than its recommended limit and prevents the load from burn-out damage. Over Voltage Protection is used to limit the amount of voltage sunk. If the OVP trips, the PEL-Series load will stop sinking voltage. Over Power Protection is used when the input power exceeds the specifications of the load. When OPP is tripped, the power will cease to be sunk. Reverse Voltage Protection prevents reverse voltage damage to the PEL-2000A Series up to the specified rating. When Reverse Voltage Protection has been tripped, an alarm tone will sound until the reverse voltage is removed. Under Voltage Protection will turn off the load when the voltage drops below a set limit. The Go/NoGo function is available to monitor test results all the time. When a test result goes beyond a preset limit range, a "No Go" indication will be shown on the display and a "No Go" signal can be sent out through the D-SUB interface for external device control. This Go/NoGo function is available for CC mode, CV mode and CR mode. Under "Program" mode, 12 programs each containing 10 panel-setup memories, can be edited to create work routines for repetitive tests. After a program has been executed, the results of all test steps, along with the Go/NoGo judgments, will be shown on the screen. For external control and system configuration, the PEL series has USB and RS232 interfaces as standard and GPIB as an option. The LabView driver and Data Logging PC software are both supported for all the available interfaces. Each channel has an analog control/monitoring connector on the rear panel to externally turn a load on/off and to externally monitor load input current and voltage.

SPECIFICATIONS

	PEL-2020A		PEL-2030A			
CHANNEL POWER RANGE	L/R 100W	L/R 100W	Left 30W	Right 250W	Right 250W	
CURRENT VOLTAGE	0-2A	0-20A	0-5A	0-4A	0-40A	
MIN. OPERATING VOLTAGE (DC)(Typ.)	0.4V at 2A 0.2V at 1A	0.8V at 20A 0.4V at 10A	0.8V at 5A 0.4V at 2.5A	0.4V at 4A 0.2V at 2A	0.8V at 40A 0.4V at 20A	
STATIC MODE						
CONSTANT CURRENT MODE	Operating Range Setting Range Resolution Accuracy	0-2A 0-2.04A 0.1mA ±(0.1%set + 0.1%F.S.)	0-20A 0-20.4A 1mA ±(0.1%set + 0.2%F.S.)	0-5A 0-5.1A 0.125mA ±(0.1%set + 0.1%F.S.)	0-4A 0-4.08A 0.1mA ±(0.1%set + 0.1%F.S.)	0-40A 0-40.8A 1mA ±(0.1%set + 0.2%F.S.)
CONSTANT RESISTANCE MODE	Operating Range Setting Range Resolution Accuracy (with ≥ 2.5V at input)	0.075Ω-300Ω(100W/16V) 3.75Ω-15K(100W/80V) 0.075Ω-300Ω(100W/16V) 3.75Ω-15K(100W/80V) 0.333mS(100W/16V) 6.667μS(100W/80V) 300Ω: ±(0.2%set+0.1S) 15KΩ: ±(0.1%set+0.01S)	0.3Ω-1.2KΩ(30W/16V) 15Ω-60K(30W/80V) 0.3Ω-1.2KΩ(30W/16V) 15Ω-60K(30W/80V) 83.333μS(30W/16V) 1.666μS(30W/80V) 1.2KΩ±(0.2%set+0.1S) 60KΩ±(0.1%set+0.01S)	0.0375Ω-150Ω(250W/16V) 1.875Ω-7.5K(250W/80V) 0.0375Ω-150Ω(250W/16V) 1.875Ω-7.5K(250W/80V) 0.666mS(250W/16V) 13.333μS(250W/80V) 150Ω: ±(0.2%set+0.1S) 7.5KΩ: ±(0.1%set+0.01S)		
CONSTANT VOLTAGE+ CONSTANT CURRENT MODE	Operating Range Setting Range Resolution Accuracy Current Setting Range Resolution Accuracy	1-80V 0-81.6V 2mV ±(0.05%set + 0.1%F.S.) 0-20A 1mA ±(0.1%set + 0.2%F.S.)	0-5A 0.125mA	0-40A 1mA		

CONSTANT POWER MODE Operating Range* Setting Range Resolution Accuracy	1~10W 0~10.2W 1mW $\pm(0.5\%set + 0.5\%F.S.)$	1~100W 0~102W 10mW $\pm(0.5\%set + 0.5\%F.S.)$	1~30W 0~30.6W 1mW $\pm(0.5\%set + 0.5\%F.S.)$	1~25W 0~25.5W 1mW $\pm(0.5\%set + 0.5\%F.S.)$	1~250W 0~255W 10mW $\pm(0.5\%set + 0.5\%F.S.)$
DYNAMIC MODE					
T1&T2 Accuracy	0.025mS~10mS/Res:1 μ S 10mS~30S/Res:1mS 1 μ S/1mS ± 100 ppm			0.025mS~10mS/Res:1 μ S 10mS~30S/Res:1mS 1 μ S/1mS ± 100 ppm	
CONSTANT CURRENT MODE Slew Rate ($\pm 10\%set+15\mu$ S) Slew Rate Resolution Slew Rate Accuracy of Setting Current Setting Range Current Resolution Current Accuracy	0.32~80mA/ μ S 0.32mA/ μ S $\pm(10\%+15\mu$ S) 0~2A 0.1mA $\pm 0.4\%$ F.S.	3.2~800mA/ μ S 3.2mA/ μ S $\pm(10\%+15\mu$ S) 0~20A 1mA $\pm 0.4\%$ F.S.	0.8~200mA/ μ S 0.8mA/ μ S $\pm(10\%+15\mu$ S) 0~5A 0.125mA $\pm 0.4\%$ F.S.	0.64~160mA/ μ S 0.64mA/ μ S $\pm(10\%+15\mu$ S) 0~4A 0.1mA $\pm 0.4\%$ F.S.	6.4~1600mA/ μ S 6.4mA/ μ S $\pm(10\%+15\mu$ S) 0~40A 1mA $\pm 0.4\%$ F.S.
CONSTANT RESISTANCE MODE Slew Rate Slew Rate Resolution Slew Rate Accuracy of setting	0.32~80mA/ μ S 0.32mA/ μ S $\pm(10\%+15\mu$ S)	3.2~800mA/ μ S 3.2mA/ μ S $\pm(10\%+15\mu$ S)	0.8~200mA/ μ S 0.8mA/ μ S $\pm(10\%+15\mu$ S)	0.64~160mA/ μ S 0.64mA/ μ S $\pm(10\%+15\mu$ S)	6.4~1600mA/ μ S 6.4mA/ μ S $\pm(10\%+15\mu$ S)
Resistance Setting Range	0.075 Ω ~300K Ω (100W/16V) 3.75 Ω ~15K(100W/80V)	0.3 Ω ~1.2K Ω (30W/16V) 15 Ω ~60K(30W/80V)	0.0375 Ω ~150K Ω (250W/16V) 1.875 Ω ~7.5K(250W/80V)	0.0375 Ω ~150K Ω (250W/16V) 1.875 Ω ~7.5K(250W/80V)	0.0375 Ω ~150K Ω (250W/16V) 1.875 Ω ~7.5K(250W/80V)
Resistance Resolution	0.333mS(100W/16V) 6.667 μ S(100W/80V)	83.333 μ S(30W/16V) 1.666 μ S(30W/80V)	0.666mS(250W/16V) 13.333 μ S(250W/80V)	0.666mS(250W/16V) 13.333 μ S(250W/80V)	0.666mS(250W/16V) 13.333 μ S(250W/80V)
Resistance Resolution	300 Ω : $\pm(0.5\%set+0.1S)$ 15K Ω : $\pm(0.5\%set+0.01S)$	1.2K Ω : $\pm(0.5\%set+0.1S)$ 60K Ω : $\pm(0.5\%set+0.01S)$	150 Ω : $\pm(0.5\%set+0.1S)$ 7.5K Ω : $\pm(0.5\%set+0.01S)$	150 Ω : $\pm(0.5\%set+0.1S)$ 7.5K Ω : $\pm(0.5\%set+0.01S)$	150 Ω : $\pm(0.5\%set+0.1S)$ 7.5K Ω : $\pm(0.5\%set+0.01S)$
MEASUREMENT					
VOLTAGE READBACK Range Resolution Accuracy	0~16V 0.32mV $\pm(0.025\%set + 0.025\%F.S.)$	0~80V 1.6mV	0~16V,0~80V 0.32mV,1.6mV	0~16V 0.32mV	0~80V 1.6mV
CURRENT READBACK Range Resolution Accuracy	0~2A 0.04mA $\pm(0.05\%set + 0.05\%F.S.)$	0~20A 0.4mA	0~5A 0.1mA	0~4A 0.08mA	0~40A 0.8mA
POWER READBACK Range Accuracy	0~10W $\pm(0.1\%set + 0.1\%F.S.*1)$	0~100W	0~30W	0~25W	0~250W
*1 : Power F.S.=Vrange F.S. x Irange F.S.					
PROTECTION					
OVER POWER PROTECTION Range Resolution Accuracy	1~102W 0.5W $\pm(2\%set+0.25\%F.S.)$	1~30.6W 0.15W $\pm(2\%set+0.25\%F.S.)$	1~255W 1.25W $\pm(2\%set+0.25\%F.S.)$		
OVER CURRENT PROTECTION Range Resolution Accuracy	0~20.4A 0.05A $\pm(2\%set+0.25\%F.S.)$	0~5.1A 0.0125A $\pm(2\%set+0.25\%F.S.)$	0~40.8A 0.1A $\pm(2\%set+0.25\%F.S.)$		
OVER VOLTAGE PROTECTION Range Resolution Accuracy	1~81.6V 0.2V $\pm(2\%set+0.25\%F.S.)$	1~81.6V 0.2V $\pm(2\%set+0.25\%F.S.)$	1~81.6V 0.2V $\pm(2\%set+0.25\%F.S.)$		
Over Temperature Protection	$\approx 85^{\circ}C$				
RATED POWER PROTECTION Value Accuracy	110W $\pm(2\%set)$	33W $\pm(2\%set)$	275W $\pm(2\%set)$		
GENERAL					
SHORT CIRCUIT Current(CC) Voltage(CV) Resistance(CR)	$\approx 2.2/2A$ 0V $\approx 3.75\Omega$	$\approx 22/20A$ 0V $\approx 0.075\Omega$	$\approx 5.5/5A$ 0V $\approx 15\Omega, \approx 0.3\Omega$	$\approx 4.4/4A$ 0V $\approx 1.875\Omega$	$\approx 44/40A$ 0V $\approx 0.0375\Omega$
INPUT RESISTANCE(LOAD OFF)	500K Ω (Typical)				
POWER SOURCE	AC100V ~ 230V $\pm 10\%$; 50Hz / 60Hz ± 2 Hz				
WEIGHT	Approx. 3.8 kg				
DIMENSIONS & WEIGHT (PEL-2002A)	272(W) x 200(H) x 581(D) mm ; Approx. 17.1kg(full modules)				
DIMENSIONS & WEIGHT (PEL-2004A)	435(W) x 200(H) x 581(D) mm ; Approx. 28.4kg(full modules)				

PEL-001 GPIB Card



PEL-002 Rack Mount Kit



PEL-003 Panel Cover



Programmable D.C. Electronic Load

PEL-2004A Rear Panel



PEL-2002A Rear Panel



PEL-2000A Series

SPECIFICATIONS

	PEL-2040A		PEL-2041A	
CHANNEL	One channel	One channel	One channel	One channel
RANGE	Low	High	Low	High
POWER	350W	350W	350W	350W
CURRENT	0-7A	0-70A	0-1A	0-10A
VOLTAGE	0-80V	0-80V	0-500V	0-500V
MIN.OPERATING VOLTAGE (DC)(Typ.)	0.4V at 7A 0.2V at 3.5A	0.8V at 70A 0.4V at 35A	0.4V at 1A 0.2V at 0.5A	0.8V at 10A 0.4V at 5A
STATIC MODE				
CONSTANT CURRENT MODE				
Operating Range	0-7A	0-70A	0-1A	0-10A
Setting Range	0-7.14A	0-71.4A	0-1.02A	0-10.2A
Resolution	0.2mA	2mA	0.05mA	0.5mA
Accuracy	±(0.1%set+ 0.1%F.S.)	±(0.1%set+ 0.2%F.S.)	±(0.1%set+ 0.1%F.S.)	±(0.1%set+ 0.2%F.S.)
CONSTANT RESISTANCE MODE				
Operating Range	0.025Ω-100Ω(350W/16V) 1.25Ω-5K(350W/80V)		1.25Ω-5KΩ(350W/125V) 50Ω-200K(350W/500V)	
Setting Range	0.025Ω-100Ω(350W/16V) 1.25Ω-5K(350W/80V)		1.25Ω-5Ω(350W/125V) 50Ω-200K(350W/500V)	
Resolution	1mS(350W/16V) 20μS(350W/80V)		20μS(350W/125V) 0.5μS(350W/500V)	
Accuracy (with≥ 2.5V at input)	100Ω: ±(0.2%set+0.1S) 5KΩ: ±(0.1%set+0.01S)		5KΩ: ±(0.2%set+0.02S) 200KΩ: ±(0.1%set+0.005S)	
CONSTANT VOLTAGE+CONSTANT CURRENT MODE				
Operating Range	1-80V		2.5-500V	
Setting Range	0-81.6V		0-510V	
Resolution	2mV		10mV	
Accuracy	±(0.05%set+ 0.1%F.S.)		±(0.05%set+ 0.1%F.S.)	
Current Setting Range	0-70A		0-10A	
Resolution	2mA		0.5mA	
Accuracy	±(0.1%set+ 0.2%F.S.)			
CONSTANT POWER MODE				
Operating Range*	1-35W	1-350W	1-35W	1-350W
Setting Range	0-35.7W	0-357W	0-35.7W	0-357W
Resolution	1mW	10mW	1mW	10mW
Accuracy	±(0.5%set+ 0.5%F.S)	±(0.5%set+ 0.5%F.S)	±(0.5%set+ 0.2%F.S)	±(0.5%set+ 0.5%F.S)
DYNAMIC MODE				
T1&T2	0.025mS-10mS/Res:1μS 10mS-30S/Res:1mS		0.025mS-10mS/Res:1μS 10mS-30S/Res:1mS	
Accuracy	1μS/1mS±100ppm		1μS/1mS±100ppm	
CONSTANT CURRENT MODE				
Slew Rate (±10%set+15μS)	0.001-0.28A/μS	0.01-2.8A/μS	0.16-40mA/μS	1.6-400mA/μS
Slew Rate Resolution	0.001A/μS	0.01A/μS	0.16mA/μS	1.6mA/μS
Slew Rate Accuracy of Setting	±(10%+15μs)	±(10%+15μs)	±(10%+15μs)	±(10%+15μs)
Current Setting Range	0-7A	0-70A	0-1A	0-10A
Current Resolution	0.2mA	2mA	0.05mA	0.5mA
Current Accuracy	±0.4% F.S.	±0.4% F.S.	±0.4%F.S.	±0.4%F.S.
CONSTANT RESISTANCE MODE				
Slew Rate	0.001-0.28A/μS	0.01-2.8A/μS	0.16-40mA/μS	1.6-400mA/μS
Slew Rate Resolution	0.001A/μS	0.01A/μS	0.16mA/μS	1.6mA/μS
Slew Rate Accuracy of setting	±(10%+15μs)	±(10%+15μs)	±(10%+15μs)	±(10%+15μs)
Resistance Setting Range	0.025Ω-100Ω(350W/16V) 1.25Ω-5K(350W/80V)		1.25Ω-5KΩ(350W/125V) 50Ω-200K(350W/500V)	
Resistance Resolution	1mS(350W/16V) 20μS(350W/80V)		20μS(350W/125V) 0.5μS(350W/500V)	
Resistance Resolution	100Ω: ±(0.5%set+ 0.1S) 5KΩ: ±(0.5%set+ 0.01S)		5KΩ: ±(0.5%set+ 0.02S) 200KΩ: ±(0.5%set+ 0.005S)	
Resistance Accuracy				

SPECIFICATIONS				
	PEL-2040A		PEL-2041A	
MEASUREMENT				
VOLTAGE READBACK				
Range	0~16V	0~80V	0~125V	0~500V
Resolution	0.32mV	1.6mV	2.5mV	10mV
Accuracy	$\pm(0.025\%set + 0.025\%F.S.)$			
CURRENT READBACK				
Range	0~7A	0~70A	0~1A	0~10A
Resolution	0.14mA	1.4mA	0.02mA	0.2mA
Accuracy	$\pm(0.05\%set + 0.05\%F.S.)$			
POWER READBACK				
Range	0~35W	0~350W	0~35W	0~350W
Accuracy	$\pm(0.1\%set + 0.1\%F.S.)$ *1 : Power F.S.=Vrange F.S. x Irange F.S.			
PROTECTION				
OVER POWER PROTECTION				
Range	1~357W		1~357W	
Resolution	1.75W		1.75W	
Accuracy	$\pm(2\%set+0.25\%F.S.)$		$\pm(2\%set+0.25\%F.S.)$	
OVER CURRENT PROTECTION				
Range	0~71.4A		0~10.2A	
Resolution	0.175A		0.025A	
Accuracy	$\pm(2\%set+0.25\%F.S.)$		$\pm(2\%set+0.25\%F.S.)$	
OVER VOLTAGE PROTECTION				
Range	1~81.6V		1~510V	
Resolution	0.2V		1.25V	
Accuracy	$\pm(2\%set+0.25\%F.S.)$		$\pm(2\%set+0.25\%F.S.)$	
Over Temperature Protection	$\approx 85^{\circ}C$		$\approx 85^{\circ}C$	
RATED POWER PROTECTION				
Value	385W		385W	
Accuracy	$\pm(2\%set)$		$\pm(2\%set)$	
GENERAL				
SHORT CIRCUIT				
Current(CC)	$\approx 7.7/7A$	$\approx 77/70A$	$\approx 1.1/1A$	$\approx 11/10A$
Voltage(CV)	0V	0V	0V	0V
Resistance(CR)	$\approx 1.25\Omega$	$\approx 0.025\Omega$	$\approx 15\Omega, \approx 50\Omega$	$\approx 1.25\Omega$
INPUT RESISTANCE(LOAD OFF)	500K Ω (Typical)			
POWER SOURCE	AC100V ~ 230V $\pm 10\%$; 50Hz / 60Hz $\pm 2Hz$			
WEIGHT	Approx. 3.8 kg			
DIMENSIONS & WEIGHT (PEL-2002A)	272(W) x 200(H) x 581 (D) mm ; Approx. 17.1kg(full modules)			
DIMENSIONS & WEIGHT (PEL-2004A)	435(W) x 200(H) x 581 (D) mm ; Approx. 28.4kg(full modules)			

GTL-249 Frame Link Cable



GTL-120 Test Lead



GTL-121 Sense Lead



ORDERING INFORMATION

PEL-2020A	Dual Channel Module, (0~80V, 0~20A, 100W) x 2
PEL-2030A	Dual Channel Module, (1~80V, 0~5A, 30W)+(1~80V, 0~40A, 250W)
PEL-2040A	Single Channel Module, (0~80V, 0~70A, 350W)
PEL-2041A	Single Channel Module, (0~500V, 0~10A, 350W)
PEL-2004A	4-Slot Programmable D.C. Electronic Load Mainframe
PEL-2002A	2-Slot Programmable D.C. Electronic Load Mainframe

Note : Load module cannot be used without a mainframe

ACCESSORIES :

PEL-2002A/2004A	User Manual x1, Power Cord x1
PEL-2020A/2030A/2040A/2041A	GTL-120 Test Lead x 1, GTL-121 Sense Lead x 1

* PEL-003 x 3 (PEL-2004A); PEL-003 x 1 (PEL-2002A)

OPTIONAL ACCESSORIES

PEL-001	GPIB Card
PEL-002	PEL-2000A Series Rack Mount Kit
PEL-003	Panel Cover
GTL-248	GPIB Cable (2m)
GTL-249	Frame Link Cable
GTL-246	USB Cable, USB 2.0 A-B TYPE CABLE, 4P
GTL-232	RS-232C Cable, 9-pin, F-F Type, null modem, 2000mm





















ACCESSORIES

MODEL	DESCRIPTION	APPLICABLE DEVICE
APS-001	GPIB interface card	APS-7000 Series
APS-002	RS-232 / USB interface card	APS-7050, APS-7100
APS-003	Output Voltage Capacity (0 – 600Vrms)	APS-7000 Series
APS-004	Output Frequency Capacity (45–999.9Hz)	APS-7000 Series
APS-007	RS-232 interface card	APS-7200, APS-7300
GET-001	Extended terminal for 30V/80V/160V models	PSW-Series
GET-002	Extended terminal for 250V/800V models	PSW-Series
GPS-001	Knob, Voltage/Current Protection Knob	GPS-x303 Series, SPD-3606
GPW-001	UL/CSA Power Cord, 3000mm	PSU-Series
GPW-002	VDE Power Cord, 3000mm	PSU-Series
GPW-003	PSE Power Cord, 3000mm	PSU-Series
GRA-401	Rack Mount Kit, 19", 4U Size	GPC-Series, GPR-M Series, PPE-3323, PPS-3635, PPT-Series, PEL-300
GRA-403	Rack Mount Kit, 19", 4U Size	PSH-Series
GRA-407	Rack Mount Kit, 19", 4U Size	PSM-Series, PST-Series
GRA-408	Rack Mount Kit, 19", 4U Size	PSS-Series
GRA-409	Rack Mount Kit, 19", 5U Size	APS-1102A
GRA-410-E	Rack Mount Kit (EIA), 19", 3U Size	PSW-Series
GRA-410-J	Rack Mount Kitt (JIS), 19", 3U Size	PSW-Series
GRA-413-E	Rack Mount Kitt (EIA), 19", 3U Size	PEL-3211/3211H
GRA-413-J	Rack Mount Kitt (JIS), 19", 3U Size	PEL-3211/3211H
GRA-414-E	Rack Mount Kit (EIA), 19", 3U Size	PEL-3021(H)/3041(H)/3111(H), PEL-3000E Series
GRA-414-J	Rack Mount Kit (JIS), 19", 3U Size	PEL-3021(H)/3041(H)/3111(H), PEL-3000E Series
GRA-418-E	Rack Mount Kit (EIA), 19", 3U Size	PSB-1000 Series
GRA-418-J	Rack Mount Kit (JIS), 19", 3U Size	PSB-1000 Series
GRA-419-E	Rack Mount Kit (EIA), 19", 2U Size	PCS-1000I
GRA-419-J	Rack Mount Kit (JIS), 19", 2U Size	PCS-1000I
GRA-423	Rack Mount Kit, 19", 2U Size	APS-7000/7000E Series
GRA-424	Rack Mount Kit, 19", 3U Size	PSB-2000 Series
GRA-427	Rack Mount Kit, 19", 3U Size	PLR-Series
GRA-429	Rack Mount Kit, 7U Size	APS-7200 Series
GRA-430	Rack Mount Kit, 9U Size	APS-7300 Series
GRA-431-J	Rack Mount Kit (JIS)	PFR-Series
GRA-431-E	Rack Mount Kit (EIA)	PFR-Series
GRJ-1101	Module Cable (0.5m)	PSB-2000 Series, PLR-Series
GRJ-1102	Module Cable (1.5m)	PLR-Series
GRM-001	Slide bracket 2pcs/set	PSU-Series
GTL-104A	Test Lead, U-type to Alligator Test Lead, Max. Current 10A, 1000mm	PFR/PSM/PSP/PSS/PST/GPC/GPD/GPP/GPR/GPS/GPE/PPT-Series, PPS-3635, SPD-3606
GTL-105A	Test Lead, Alligator to Banana Test Lead, Max. Current 3A, 1000mm	PFR/PSS/PST/GPC/GPD/GPP/GPR/GPS/GPE/PPT-Series, PEL-2000A, PPE-3323, SPD-3606, PCS-1000I
GTL-117	Test Lead, Banana to Probe Test Lead, 1200mm	PPH-1503/1503D/1506D
GTL-120	Test Lead, O-type to O-type Test Lead, Max. 40A, 1200mm	PEL-3000/3000H Series, PEL-2000A Series
GTL-121	Sense Lead, O-type to free Lead, 1200mm	PEL-2000A Series
GTL-122	Test Lead, U-type to Alligator Test Lead, Max. Current 40A, 1200mm	PSH-Series, GPR-U Series, GPR-H Series
GTL-123	Test Lead, O-type to O-type Test Lead, 1200mm	PSW-Series, APS-7000 Series, PSB-1000 Series
GTL-130	Test leads: 2 x red, 2 x black, for 250V/800V models, 1200mm	PSW-Series
GTL-134	Test leads for rear panel, 1200mm, 10A, 16 AWG	PFR-Series
GTL-201A	Ground Lead, Banana to Banana, European Terminal, 200mm	AFG-200/100 Series, PSM Series, GPD-Series, GPP-Series, GPS-X303 Series, SPD-3606
GTL-202	Sense Lead, Banana to Banana Lead, European Terminal, 200mm	PSM-Series
GTL-203A	Test Lead, Banana to Alligator, European Terminal, Max. Current 3A, 1000mm	PSS/PST/GPD/GPP/GPS/GPE/PPT-Series, SPD-3606, PPH-1503/1503D/1506D
GTL-204A	Test Lead, Banana to Alligator, European Terminal, Max. Current 10A, 1000mm	PSM/PSP/PSS/GPS/GPE/PPT/PST/GPD/GPP-Series, SPD-3606, PPH-1503/1503D/1506D
GTL-207A	Test Lead, Banana to Probe Test Lead, 800mm	PCS-1000I
GTL-232	RS-232C Cable, 9-pin, F-F Type, null modem, 2000mm	PSH/PSM/PSS/PST-Series, APS-7000 Series, PEL-2000A Series
GTL-232A	RS-232C Cable, 9-pin, F-F Type, null modem, 2000mm	PSP-Series
GTL-234	RS-232C Cable, 9-pin, F-F Type, 2000mm	APS-1102A
GTL-240	USB Cable, USB 2.0, A-B Type (L Type), 1200mm	PSW-Series, PSU-Series, APS-1102A, APS-7000 Series, PCS-1000I
GTL-246	USB Cable, USB 2.0, A-B Type, 1200mm	PFR-Series, PSU-Series, PSB-2000 Series, PPH-1503/1503D, GPD-Series, GPP-Series, APS-1102A, APS-7000 Series, PEL-3000/3000H Series, PEL-3000E, PEL-2000A Series, PLR-Series
GTL-248	GPIB Cable, Double Shielded, 2000mm	PSB-2000 Series, PPH-1503, PSW/PSU/PSH/PSM/PSS/PST/PPT-Series, PPS-3635, APS-7000 Series, PEL-3000/3000E/2000A Series, PEL-2000A Series, PLR-Series
GTL-249	Frame Link Cable, 300mm	PEL-2000A Series
GTL-250	GPIB Cable, Double Shielded, 600mm	PSW/PSU/PSH-Series, PSB-2000 Series, APS-7000 Series
GTL-251	USB-GPIB Adapter, GPIB-USB-HS	PSB-2000 Series, PPH-1503, PSW/PSU/PSH/PSM/PSS/PST/PPT-Series, PPS-3635, APS-7000 Series, PEL-3000/3000E/2000A Series, PLR-Series, GPP-Series
GTL-255	Frame Link Cable, 300mm	PEL-3000/3000H Series
GTL-258	GPIB Cable, 25 pins Micro-D Connector	PFR-Series
GUG-001	GPIB-USB Adaptor, GPIB to USB adaptor	GDS-3000 Series, PSW-Series
GUR-001	RS232-USB Cable ,300mm	PSW-Series
PCS-001	Basic Accessory Kit	PCS-1000I
PEL-001	GPIB Card	PEL-2000A Series
PEL-011	Load Input Terminal Cover	PEL-3000/3000H Series
PEL-012	Terminal Fittings Kits	PEL-3000/3000H Series
PEL-013	Flexible Terminal Cover	PEL-3000/3000H Series
PEL-014	J1/J2 Protection Plug	PEL-3000/3000H Series
PEL-002	Rack Mount Kit, PEL-2000 Series Rack Mount Kit	PEL-2000A Series
PEL-003	Panel Cover	PEL-2000A Series
PEL-004	GPIB Card	PEL-3000/3000H Series, PEL-3000E Series
PEL-005	Connect Cu Plate	PEL-3000/3000H Series
PEL-006	Connect Cu Plate	PEL-3000/3000H Series
PEL-007	Connect Cu Plate	PEL-3000/3000H Series
PEL-008	Connect Cu Plate	PEL-3000/3000H Series
PEL-009	Connect Cu Plate	PEL-3000/3000H Series

ACCESSORIES

MODEL	DESCRIPTION	APPLICABLE DEVICE
PEL-010	Dust filter	PEL-3000/3000H Series, PEL-3000E Series
PLR-CU	GPiB/USB Interface Card	PLR-Series
PLR-LU	LAN/USB Interface Card	PLR-Series
PLR-ARC	External Analog Control Interface Card	PLR-Series
PLR-001	Parallel Connection Signal Cable(2~3 units)	PLR-Series
PLR-002	Series Connection Signal Cable	PLR-Series
PSB-001	GPiB Card	PSB-2000 Series, PSB-1000 Series
PSB-003	Parallel connection kit (for horizontal installation), Kit includes: (PSB-007 Joint Kit, Horizontal bus bar x 2, PSB-005 x1)	PSB-2000 Series, PSB-1000 Series
PSB-004	Parallel connection kit (for vertical installation) Kit includes: (PSB-007 Joint Kit, Vertical bus bar x 2, PSB-005 x 1)	PSB-2000 Series, PSB-1000 Series
PSB-005	Parallel Connection Signal Cable	PSB-2000 Series, PSB-1000 Series
PSB-006	Serial Connection Signal Cable	PSB-2000 Series, PSB-1000 Series
PSB-007	Joint Kit: Includes 4 joining plates, [M3x6]screws x 4 ; [M3x8]screw x 2	PSB-2000 Series
PSB-008	RS232C Cable (PSB-2000 Only)	PSB-2000 Series
PSB-101	Cable for 2 units of PSB-1000 units in parallel mode connection	PSB-1000 Series
PSB-102	Cable for 3 units of PSB-1000 units in parallel mode connection	PSB-1000 Series
PSB-103	Cable for 4 units of PSB-1000 units in parallel mode connection	PSB-1000 Series
PSB-104	Cable for 2 units of PSB-1000 units in series mode connection	PSB-1000 Series
PSB-105	GPiB card	PSB-1000 Series
PSB-106	basic accessory kit : M4 terminal screws and washers x 2, M8 terminal bolts, nuts and washers x 2, analog control protection dummy x 1, analog control lock level x 2, short bar x 1	PSB-1000 Series
PSU-01A	Joins a vertical stack of 2 PSU units together. 2U-sized handles x2, joining plates x2	PSU-Series
PSU-01B	Bus Bar for 2 units in parallel operation	PSU-Series
PSU-01C	Cable for 2 units in parallel operation	PSU-Series
PSU-02A	Joins a vertical stack of 3 PSU units together. 3U-sized handles x2, joining plates x2	PSU-Series
PSU-02B	Bus Bar for 3 units in parallel operation	PSU-Series
PSU-02C	Cable for 3 units in parallel operation	PSU-Series
PSU-03A	Joins a vertical stack of 4 PSU units together. 4U-sized handles x2, joining plates x2	PSU-Series
PSU-03B	Bus Bar for 4 units in parallel operation	PSU-Series
PSU-03C	Cable for 4 units in parallel operation	PSU-Series
PSU-232	RS232 Cable with DB9 connector kit	PSU-Series, PFR-Series
PSU-485	RS485 Cable with DB9 connector kit	PSU-Series, PFR-Series
PSU-GPiB	PSU GPiB Interface Card (Factory Installed)	PSU-Series
PSU-ISO-I	Isolated Current Remote Control Card (Factory Installed)	PSU-Series
PSU-ISO-V	Isolated Voltage Remote Control Card (Factory Installed)	PSU-Series
PSW-001	Accessory Kits	PSW-Series, PSB-1000 Series
PSW-002	Simple IDC Tool	PSW-Series, PSB-1000 Series
PSW-003	Contact Removal Tool	PSW-Series, PSB-1000 Series
PSW-004	Basic Accessory Kit for 30V/80V/160V models	PSW-Series
PSW-005	Series Operation Cable for 2 units. (30V/80V/160V models moly)	PSW-Series
PSW-006	Parallel Operation Cable for 2 units.	PSW-Series
PSW-007	Parallel Operation Cable for 3 units.	PSW-Series
PSW-008	Basic Accessory Kit for 250V/800V models	PSW-Series
PSW-009	Output terminal cover for 30V/80V/160V models	PSW-Series
PSW-010	Large filter (Type II/III)	PSW-Series
PSW-011	Output terminal cover for 250V/800V models	PSW-Series
PSW-012	High voltage output terminal for 250V/800V model	PSW-Series

ACCESSORIES

<p>GTL-101</p> 	<p>GTL-105A</p> 	<p>GTL-104A</p> 
<p>GTL-120</p> 	<p>GTL-121</p> 	<p>GTL-122</p> 
<p>GTL-123</p> 	<p>GTL-201A</p> 	<p>GTL-202</p> 
<p>GTL-203A</p> 	<p>GTL-204A</p> 	<p>GTL-232</p> 
<p>GTL-232A</p> 	<p>GTL-240</p> 	<p>GTL-246</p> 
<p>GTL-248</p> 	<p>GTL-250</p> 	<p>GTL-253</p> 
<p>GRA-401 Rack Mount Kit</p> 		<p>GRA-408 Rack Mount Kit</p> 

ACCESSORIES

PEL-002 Rack Mount Kit

For: PEL-2000A Series

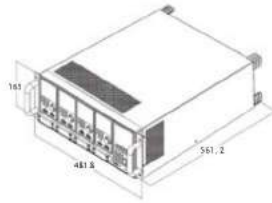

GRA-409 Rack Mount Kit

For: APS-1102A

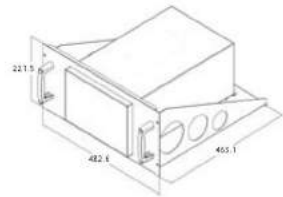

GRA-403 Rack Mount Kit

For: PSH-Series

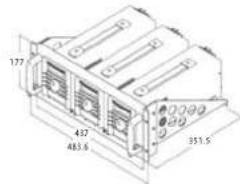

GRA-410-J Rack Mount Kit (JIS)

For: PSW-Series

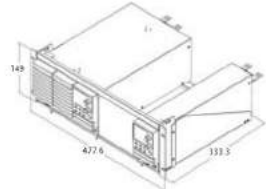

GRA-407 Rack Mount Kit

For: PSM-Series, PST-Series

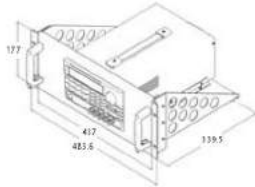

GRA-410-E Rack Mount Kit (EIA)

For: PSW-Series

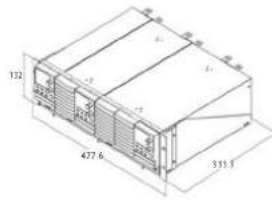

GRA-413-J Rack Mount Kit (JIS)

For: PEL-3211

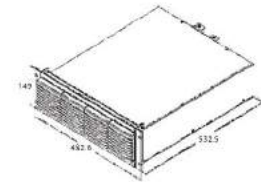

GRA-414-J Rack Mount Kit (JIS)

For: PEL-3021/3041/3111

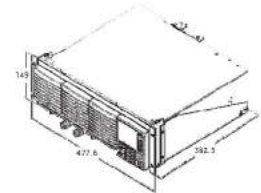

GRA-413-E Rack Mount Kit (EIA)

For: PEL-3211

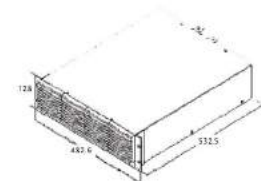

GRA-414-E Rack Mount Kit (EIA)

For: PEL-3021/3041/3111

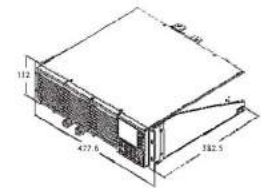

GRA-423 Rack Mount Kit

For: APS-7050/7100/7050E/7100E Series

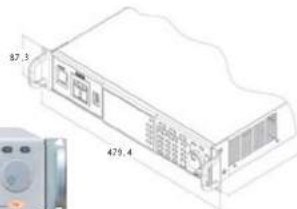

GRA-424 Rack Mount Kit

For: PSB-2000 Series

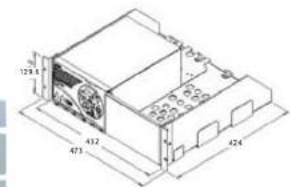

GRA-418-J Rack Mount Kit (JIS)

For: PSB-1000 Series

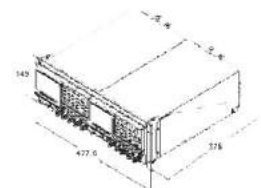

GRA-419 Rack Mount Kit (JIS)

For: PCS-1000I

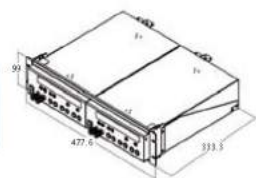

ACCESSORIES

GRA-418-E Rack Mount Kit (EIA)

For : PSB-1000 Series



GRA-419 EIA Rack Mount Kit

For : PCS-1000

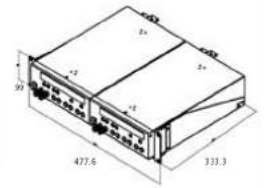

GRA-424 Rack Mount Kit

For : PSB-2000 Series

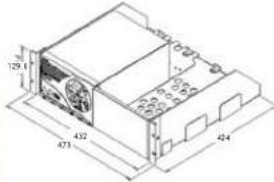

GRA-427 Rack Mount Kit (EIA+JIS)

For : PLR-Series

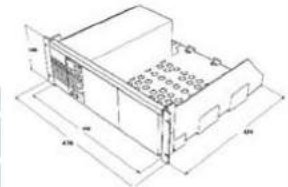

GRA-429 Rack Mount Kit

For : APS-7200 Series

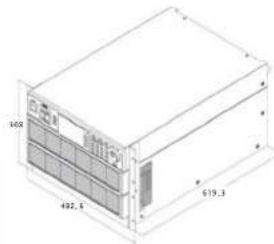

GRA-430 Rack Mount Kit

For : APS-7300 Series

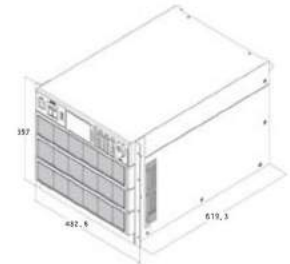

GRA-431-J Rack Mount Kit (JIS)with AC 100V/200V

For : PFR-Series

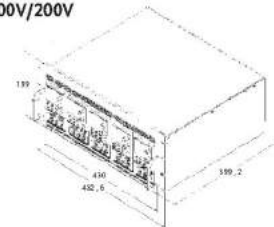

GRA-431-E Rack Mount Kit (EIA)with AC 100V/200V

For : PFR-Series

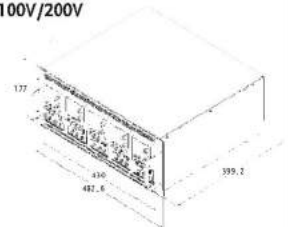

ACCESSORIES

ACCESSORIES

ELECTRONIC LOAD



GW INSTEK WINS TAIWAN EXCELLENCE AWARD



台灣精品
TAIWAN EXCELLENCE



GW INSTEK WINS TECHNOLOGY INNOVATION AWARD



科技創新獎
TAITRONICS



For more information, please visit our website: <http://www.gwinstek.com>

DISTRIBUTOR :

Specifications subject to change without notice.

2019POWER_GC1-2019.06-2000

Global Headquarters

GOOD WILL INSTRUMENT CO., LTD.

No.7-1, Jhongsing Road, Tucheng Dist., New Taipei City 236, Taiwan

T +886-2-2268-0389 F +886-2-2268-0639

E-mail: marketing@goodwill.com.tw

China Subsidiary

GOOD WILL INSTRUMENT (SUZHOU) CO., LTD.

No. 521, Zhujiang Road, Snd, Suzhou Jiangsu 215011 China

T +86-512-6661-7177 F +86-512-6661-7277

Malaysia Subsidiary

GOOD WILL INSTRUMENT (SEA) SDN. BHD.

No. 1-3-18, Elit Avenue, Jalan Mayang Pasir 3,

11950 Bayan Baru, Penang, Malaysia

T +604-6111122 F +604-6115225

Europe Subsidiary

GOOD WILL INSTRUMENT EURO B.V.

De Run 5427A, 5504DG Veldhoven, THE NETHERLANDS

T +31(0)40-2557790 F +31(0)40-2541194

U.S.A. Subsidiary

INSTEK AMERICA CORP.

5198 Brooks Street Montclair, CA 91763, U.S.A.

T +1-909-399-3535 F +1-909-399-0819

Japan Subsidiary

TEXIO TECHNOLOGY CORPORATION.

7F Towa Fudosan Shin Yokohama Bldg., 2-18-13 Shin

Yokohama, Kohoku-ku, Yokohama, Kanagawa,

222-0033 Japan

T +81-45-620-2305 F +81-45-534-7181

Korea Subsidiary

GOOD WILL INSTRUMENT KOREA CO., LTD.

Room No.503, Gyeonginro 775 (Mullae-Dong 3Ga,

Ace Hightech-City B/D 1Dong), Yeongduengpo-Gu,

Seoul 150093, Korea.

T +82-2-3439-2205 F +82-2-3439-2207

India Subsidiary

GW INSTEK INDIA LLP.

No.2707/B&C, 1st Floor UNNATHI Building,

E-Block, Sahakara Nagar, Bengaluru-560 092, India

T +91-80-6811-0600 F +91-80-6811-0626

GW INSTEK

Simply Reliable



www.gwinstek.com

www.facebook.com/GWInstek