

# Keysight DC Electronic Loads

Models N3300A, N3301A, N3302A, N3303A  
N3304A, N3305A, N3306A, and N3307A

Programming Guide



NOTICE: This document contains references to Agilent Technologies. Agilent's former Test and Measurement business has become Keysight Technologies. For more information, go to [www.keysight.com](http://www.keysight.com).



---

## Safety Summary

The beginning of the electronic load User's Guide has a Safety Summary page. Be sure you are familiar with the information on this page before programming the electronic load from a controller.

---

## Printing History

The edition and current revision of this manual are indicated below. Reprints of this manual containing minor corrections and updates may have the same printing date. Revised editions are identified by a new printing date. A revised edition incorporates all new or corrected material since the previous printing date. Changes to the manual occurring between revisions are covered by change sheets shipped with the manual.

This document contains proprietary information protected by copyright. All rights are reserved. No part of this document may be photocopied, reproduced, or translated into another language without the prior consent of Keysight Technologies. The information contained in this document is subject to change without notice.

Edition 1 \_\_\_\_\_ August 2000  
Update1 \_\_\_\_\_ November 2000  
Edition 2 \_\_\_\_\_ March 2002  
Edition 3 \_\_\_\_\_ November 2014

---

# Table of Contents

<b>Safety Summary</b>	<b>4</b>
<b>Printing History</b>	<b>4</b>
<b>Table of Contents</b>	<b>5</b>
<b>1 - GENERAL INFORMATION</b>	<b>11</b>
<b>About this Guide</b>	<b>11</b>
Documentation Summary	11
<b>External References</b>	<b>11</b>
SCPI References	11
GPIB References	12
<b>VXIplug&amp;play Power Products Instrument Drivers</b>	<b>12</b>
Supported Applications	12
System Requirements	12
Downloading and Installing the Driver	12
Accessing Online Help	13
<b>2 - INTRODUCTION TO PROGRAMMING</b>	<b>15</b>
<b>GPIB Capabilities of the Electronic Load</b>	<b>15</b>
GPIB Address	15
<b>RS-232 Capabilities of the Electronic Load</b>	<b>16</b>
RS-232 Data Format	16
RS-232 Flow Control	16
<b>Introduction to SCPI</b>	<b>17</b>
Conventions Used in This Guide	17
<b>Types of SCPI Commands</b>	<b>17</b>
Multiple Commands in a Message	18
Moving Among Subsystems	18
Including Common Commands	18
Using Queries	19
<b>Types of SCPI Messages</b>	<b>19</b>
The Message Unit	19
Headers	19
Query Indicator	20
Message Unit Separator	20
Root Specifier	20
Message Terminator	20
<b>SCPI Data Formats</b>	<b>20</b>
Numerical Data Formats	20

Suffixes and Multipliers	21
Response Data Types	21
<b>SCPI Command Completion</b>	<b>21</b>
<b>Using Device Clear</b>	<b>22</b>
<b>RS-232 Troubleshooting</b>	<b>22</b>
<b>SCPI Conformance Information</b>	<b>23</b>
SCPI Conformed Commands	23
Non-SCPI Commands	23
<b>3 - PROGRAMMING EXAMPLES</b>	<b>25</b>
<b>Introduction</b>	<b>25</b>
<b>Programming the Input</b>	<b>25</b>
Power-on Initialization	25
Enabling the Input	25
Input Voltage	25
Input Current	26
Setting the Triggered Voltage or Current Levels	26
<b>Programming Transients</b>	<b>27</b>
Continuous Transients	27
Pulse Transients	27
Toggled Transients	28
<b>Programming Lists</b>	<b>28</b>
Programming Lists for Multiple Channels	30
<b>Triggering Transients and Lists</b>	<b>31</b>
SCPI Triggering Nomenclature	31
List Trigger Model	31
Initiating List Triggers	32
Specifying a Trigger Delay	32
Generating Transient and List Triggers	32
<b>Making Measurements</b>	<b>33</b>
Voltage and Current Measurements	33
<b>Triggering Measurements</b>	<b>35</b>
SCPI Triggering Nomenclature	35
Measurement Trigger Model	35
Initiating the Measurement Trigger System	36
Generating Measurement Triggers	36
<b>Controlling Measurement Samples</b>	<b>37</b>
Varying the Sampling Rate	37
Measurement Delay	37
Multiple Measurements	37
<b>Synchronizing Transients and Measurements</b>	<b>38</b>

Measuring Triggered Transients or Lists	38
Measuring Dwell-Paced Lists	39
<b>Programming the Status Registers</b>	<b>40</b>
Power-On Conditions	43
Channel Status Group	43
Channel Summary Group	43
Questionable Status Group	43
Standard Event Status Group	43
Operation Status Group	44
Status Byte Register	44
Determining the Cause of a Service Interrupt	45
Servicing Standard Event Status and Questionable Status Events	45
<b>Programming Examples</b>	<b>46</b>
CC Mode Example	46
CV Mode Example	46
CR Mode Example	47
Continuous Transient Operation Example	47
Pulsed Transient Operation Example	48
Synchronous Toggled Transient Operation Example	48
Battery Testing Example	49
Power Supply Testing Example	51
C++ Programming Example	52
<b>4 - LANGUAGE DICTIONARY</b>	<b>55</b>
<b>Introduction</b>	<b>55</b>
Subsystem Commands	55
Common Commands	56
Programming Parameters	56
<b>Calibration Commands</b>	<b>57</b>
CALibrate:DATA	57
CALibrate:IMON:LEVel	57
CALibrate:IPR:LEVel	57
CALibrate:LEVel	57
CALibrate:PASSword	58
CALibrate:SAVE	58
CALibrate:STATe	58
<b>Channel Commands</b>	<b>59</b>
CHANnel INSTRument	59
<b>Input Commands</b>	<b>60</b>
[SOURce:]INPut [SOURce:]OUTPut	60
[SOURce:]INPut:PROTection:CLEar [SOURce:]OUTput:PROTection:CLEar	60
[SOURce:]INPut:SHORt [SOURce:]OUTPut:SHORt	60
[SOURce:]CURRent	61
[SOURce:]CURRent:MODE	61
[SOURce:]CURRent:PROTection	61
[SOURce:]CURRent:PROTection:DELAy	62
[SOURce:]CURRent:PROTection:STATe	62
[SOURce:]CURRent:RANGE	62

[SOURce:]CURRent:SLEW	63
[SOURce:]CURRent:SLEW:NEGative	63
[SOURce:]CURRent:SLEW:POSitive	63
[SOURce:]CURRent:TLEVel	64
[SOURce:]CURRent:TRIGgered	64
[SOURce:]FUNCTion [SOURce:]MODE	64
[SOURce:]FUNCTion:MODE	65
[SOURce:]RESistance	65
[SOURce:]RESistance:MODE	65
[SOURce:]RESistance:RANGe	66
[SOURce:]RESistance:SLEW	66
[SOURce:]RESistance:SLEW:NEGative	66
[SOURce:]RESistance:SLEW:POSitive	67
[SOURce:]RESistance:TLEVel	67
[SOURce:]RESistance:TRIGgered	67
[SOURce:]VOLTage	68
[SOURce:]VOLTage:MODE	68
[SOURce:]VOLTage:RANGe	68
[SOURce:]VOLTage:SLEW	69
[SOURce:]VOLTage:SLEW:NEGative	69
[SOURce:]VOLTage:SLEW:POSitive	70
[SOURce:]VOLTage:TLEVel	70
[SOURce:]VOLTage:TRIGgered	70
<b>Measurement Commands</b>	<b>71</b>
ABORT	71
MEASure:ARRay:CURRent? FETCH:ARRay:CURRent?	71
MEASure:ARRay:POWer? FETCH:ARRay:POWer?	71
MEASure:ARRay:VOLTage? FETCH:ARRay:VOLTage?	72
MEASure:CURRent? FETCH:CURRent?	72
MEASure:CURRent:ACDC? FETCH:CURRent:ACDC?	72
MEASure:CURRent:MAXimum? FETCH:CURRent:MAXimum?	72
MEASure:CURRent:MINimum? FETCH:CURRent:MINimum?	73
MEASure:POWer? FETCH:POWer?	73
MEASure:POWer:MAXimum? FETCH:POWer:MAXimum?	73
MEASure:POWer:MINimum? FETCH:POWer:MINimum?	73
MEASure:VOLTage? FETCH:VOLTage?	74
MEASure:VOLTage:ACDC? FETCH:VOLTage:ACDC?	74
MEASure:VOLTage:MAXimum? FETCH:VOLTage:MAXimum?	74
MEASure:VOLTage:MINimum? FETCH:VOLTage:MINimum?	74
SENSe:CURRent:RANGe	75
SENSe:SWEep:POINts	75
SENSe:SWEep:OFFSet	75
SENSe:SWEep:TINTerval	76
SENSe:WINDow	76
SENSe:VOLTage:RANGe	76
<b>Port Commands</b>	<b>77</b>
PORT0	77
PORT1	77
<b>List Commands</b>	<b>78</b>
[SOURce:]LIST:COUNt	78
[SOURce:]LIST:CURRent [SOURce:]LIST:CURRent:POINts?	78
[SOURce:]LIST:CURRent:RANGe [SOURce:]LIST:CURRent:RANGe:POINts?	79



[SOURCE:]LIST:CURRENT:SLEW [SOURCE:]LIST:CURRENT:SLEW:POINTS?	79
[SOURCE:]LIST:CURRENT:SLEW:NEGATIVE	80
[SOURCE:]LIST:CURRENT:SLEW:POSITIVE	80
[SOURCE:]LIST:CURRENT:TLEVEL [SOURCE:]LIST:CURRENT:TLEVEL:POINTS?	80
[SOURCE:]LIST:FUNCTION [SOURCE:]LIST:MODE [SOURCE:]LIST:FUNCTION:POINTS?	81
[SOURCE:]LIST:DWELL [SOURCE:]LIST:DWELL:POINTS?	81
[SOURCE:]LIST:RESISTANCE [SOURCE:]LIST:RESISTANCE:POINTS?	82
[SOURCE:]LIST:RESISTANCE:RANGE [SOURCE:]LIST:RESISTANCE:RANGE:POINTS?	82
[SOURCE:]LIST:RESISTANCE:SLEW [SOURCE:]LIST:RESISTANCE:SLEW:POINTS?	83
[SOURCE:]LIST:RESISTANCE:SLEW:NEGATIVE	83
[SOURCE:]LIST:RESISTANCE:SLEW:POSITIVE	83
[SOURCE:]LIST:RESISTANCE:TLEVEL [SOURCE:]LIST:RESISTANCE:TLEVEL:POINTS?	84
[SOURCE:]LIST:STEP	84
[SOURCE:]LIST:TRANSIENT [SOURCE:]LIST:TRANSIENT:POINTS?	84
[SOURCE:]LIST:TRANSIENT:DCYCLE [SOURCE:]LIST:TRANSIENT:DCYCLE:POINTS?	85
[SOURCE:]LIST:TRANSIENT:FREQUENCY [SOURCE:]LIST:TRANSIENT:FREQUENCY:POINTS?	85
[SOURCE:]LIST:TRANSIENT:MODE [SOURCE:]LIST:TRANSIENT:MODE:POINTS?	85
[SOURCE:]LIST:TRANSIENT:TWIDTH [SOURCE:]LIST:TRANSIENT:TWIDTH:POINTS?	86
[SOURCE:]LIST:VOLTAGE [SOURCE:]LIST:VOLTAGE:POINTS?	86
[SOURCE:]LIST:VOLTAGE:RANGE [SOURCE:]LIST:VOLTAGE:RANGE:POINTS?	86
[SOURCE:]LIST:VOLTAGE:SLEW [SOURCE:]LIST:VOLTAGE:SLEW:POINTS?	87
[SOURCE:]LIST:VOLTAGE:SLEW:NEGATIVE	87
[SOURCE:]LIST:VOLTAGE:SLEW:POSITIVE	88
[SOURCE:]LIST:VOLTAGE:TLEVEL [SOURCE:]LIST:VOLTAGE:TLEVEL:POINTS?	88
<b>Transient Commands</b>	<b>89</b>
[SOURCE:]TRANSIENT	89
[SOURCE:]TRANSIENT:DCYCLE	89
[SOURCE:]TRANSIENT:FREQUENCY	89
[SOURCE:]TRANSIENT:MODE	90
[SOURCE:]TRANSIENT:LMODE	90
[SOURCE:]TRANSIENT:TWIDTH	90
<b>Status Commands</b>	<b>91</b>
Bit Configuration of Channel Status Registers	91
STATUS:CHANNEL?	91
STATUS:CHANNEL:CONDITION?	91
STATUS:CHANNEL:ENABLE	91
STATUS:CSUM?	92
STATUS:CSUMMARY:ENABLE	92
Bit Configuration of Operation Status Registers	92
STATUS:OPERATION?	92
STATUS:OPERATION:CONDITION?	92
STATUS:OPERATION:ENABLE	93
STATUS:OPERATION:NTRANSITION STATUS:OPERATION:PTRANSITION	93
Bit Configuration of Questionable Status Registers	94
STATUS:QUESTIONABLE?	94
STATUS:QUESTIONABLE:CONDITION?	94
STATUS:QUESTIONABLE:ENABLE	94
<b>System Commands</b>	<b>95</b>
SYSTEM:ERROR?	95
SYSTEM:LOCAL	95
SYSTEM:REMOTE	95
SYSTEM:RWLOCK	95

SYSTem:VERSion?	95
<b>Trigger Commands</b>	<b>96</b>
ABORt	96
INITiate:SEQuence INITiate:NAME	96
INITiate:SEQuence2 INITiate:NAME	96
INITiate:CONTInuous:SEQuence INITiate:CONTInuous:NAME	97
TRIGger	97
TRIGger:DELay	97
TRIGger:SEQuence2:COUNT	98
TRIGger:SOURce	98
TRIGger:TIMer	98
<b>Common Commands</b>	<b>99</b>
*CLS	99
*ESE	99
Bit Configuration of Standard Event Status Enable Register	100
*ESR?	100
*IDN?	100
*OPC	100
*OPT?	101
*PSC	101
*RCL	101
*RDT?	102
*RST	102
*SAV	103
*SRE	103
*STB?	103
Bit Configuration of Status Byte Register	104
*TRG	104
*TST?	104
*WAI	104
<b>A - SCPI COMMAND TREE</b>	<b>105</b>
<b>Command Syntax</b>	<b>105</b>
<b>B - ERROR MESSAGES</b>	<b>109</b>
<b>Error Number List</b>	<b>109</b>
<b>C - COMPARING N3300A ELECTRONIC LOADS WITH EARLIER MODELS</b>	<b>113</b>
<b>Introduction</b>	<b>113</b>
<b>INDEX</b>	<b>117</b>

# General Information

---

## About this Guide

This manual contains programming information for the Keysight Technologies N3301A, N3302A, N3303A, N3304A, N3305A, N3306A, and N3307A Electronic Load modules when installed in a Keysight Technologies N3300A and N3301A Electronic Load mainframes. These units will be referred to as "electronic load" throughout this manual. You will find the following information in the rest of this guide:

Chapter 1	Introduction to this guide.
Chapter 2	Introduction to SCPI messages structure, syntax, and data formats.
Chapter 3	Introduction to programming the electronic load with SCPI commands.
Chapter 4	Dictionary of SCPI commands.
Appendix A	SCPI command tree.
Appendix B	Error messages
Appendix C	Comparison With Earlier Models

## Documentation Summary

The following documents that are related to this Programming Guide have additional helpful information for using the electronic load.

- ◆ *Quick Start Guide* - located in the front part of the User's Guide. Information on how to quickly get started using the electronic load.
- ◆ *User's Guide*. Includes specifications and supplemental characteristics, how to use the front panel, how to connect to the instrument, and calibration procedures.

---

## External References

### SCPI References

The following documents will assist you with programming in SCPI:

- ◆ *Standard Commands for Programmable Instruments Volume 1, Syntax and Style*
- ◆ *Standard Commands for Programmable Instruments Volume 2, Command References*
- ◆ *Standard Commands for Programmable Instruments Volume 3, Data Interchange Format*
- ◆ *Standard Commands for Programmable Instruments Volume 4, Instrument Classes*

To obtain a copy of the above documents, contact: Fred Bode, Executive Director, SCPI Consortium, 8380 Hercules Drive, Suite P3, Ls Mesa, CA 91942, USA

## GPIB References

The most important GPIB documents are your controller programming manuals - GW BASIC, GPIB Command Library for MS DOS, etc. Refer to these for all non-SCPI commands (for example: Local Lockout).

The following are two formal documents concerning the GPIB interface:

- ◆ *ANSI/IEEE Std. 488.1-1987 IEEE Standard Digital Interface for Programmable Instrumentation.* Defines the technical details of the GPIB interface. While much of the information is beyond the need of most programmers, it can serve to clarify terms used in this guide and in related documents.
- ◆ *ANSI/IEEE Std. 488.2-1987 IEEE Standard Codes, Formats, Protocols, and Common Commands.* Recommended as a reference only if you intend to do fairly sophisticated programming. Helpful for finding precise definitions of certain types of SCPI message formats, data types, or common commands.

The above two documents are available from the IEEE (Institute of Electrical and Electronics Engineers), 345 East 47th Street, New York, NY 10017, USA.

---

## VXIplug&play Power Products Instrument Drivers

VXIplug&play instrument drivers for Microsoft Windows 95 and Windows NT are now available on the Web at <http://www.keysight.com/find/drivers>. These instrument drivers provide a high-level programming interface to your Keysight Technologies electronic load. VXIplug&play instrument drivers are an alternative to programming your instrument with SCPI command strings. Because the instrument driver's function calls work together on top of the VISA I/O library, a single instrument driver can be used with multiple application environments.

### Supported Applications

- Keysight VEE
- Microsoft Visual BASIC
- Microsoft Visual C/C++
- Borland C/C++
- National Instruments LabVIEW
- National Instruments LabWindows/CVI

### System Requirements

The VXIplug&play instrument driver complies with the following:

- Microsoft Windows 95
- Microsoft Windows NT 4.0
- HP VISA revision F.01.02
- National Instruments VISA 1.1

### Downloading and Installing the Driver

---

**NOTE:** Before installing the VXIplug&play instrument driver, make sure that you have one of the supported applications installed and running on your computer.

---

1. Access Keysight Technologies Web site at <http://www.keysight.com/find/drivers>.
2. Select the instrument for which you need the driver.
3. Click on the driver, either Windows 95 or Windows NT, and download the executable file to your PC.
4. Locate the file that you downloaded from the Web. From the **Start** menu select **Run** <path>\kexxxx.exe - where <path> is the directory path where the file is located, and kexxxx is the instrument driver that you downloaded.
5. Follow the directions on the screen to install the software. The default installation selections will work in most cases. The readme.txt file contains product updates or corrections that are not documented in the on-line help. If you decide to install this file, use any text editor to open and read it.
6. To use the *VXIplug&play* instrument driver, follow the directions in the *VXIplug&play* online help for your specific driver under "Introduction to Programming".

## Accessing Online Help

A comprehensive online programming reference is provided with the driver. It describes how to get started using the instrument driver with Keysight VEE, LabVIEW, and LabWindows. It includes complete descriptions of all function calls as well as example programs in C/C++ and Visual BASIC.

- To access the online help when you have chosen the default **Vxipnp** start folder, click on the **Start** button and select **Programs | Vxipnp | Kexxxx Help (32-bit)**.  
- where Kexxxx is the instrument driver.



## Introduction to Programming

### GPIB Capabilities of the Electronic Load

All electronic load functions except for setting the GPIB address are programmable over the GPIB. The IEEE 488.2 capabilities of the electronic load are described in Table 2-1. Refer to Appendix A of your User's Guide for its exact capabilities.

**Table 2-1. IEEE 488 Capabilities of Electronic Loads**

GPIB Capabilities	Response	Interface Function
Talker/Listener	All electronic load functions except for setting the GPIB address are programmable over the GPIB. The electronic load can send and receive messages over the GPIB. Status information is sent using a serial poll. Front panel annunciators indicate the present GPIB state of the electronic load.	AH1, SH1, T6, L4
Service Request	The electronic load sets the SRQ line true if there is an enabled service request condition. Refer to <i>Chapter 3 - Status Reporting</i> for more information.	SR1
Remote/Local	In local mode, the electronic load is controlled from the front panel but will also execute commands sent over the GPIB. The electronic load powers up in local mode and remains in local mode until it receives a command over the GPIB. Once the electronic load is in remote mode the front panel RMT annunciator is on, all front panel keys (except <b>Local</b> ) are disabled, and the display is in normal metering mode. Pressing <b>Local</b> on the front panel returns the electronic load to local mode. <b>Local</b> can be disabled using local lockout so that only the controller or the power switch can return the electronic load to local mode.	RL1
Device Trigger	The electronic load will respond to the device trigger function.	DT1
Group Execute Trigger	The electronic load will respond to the group execute trigger function.	GET
Device Clear	The electronic load responds to the Device Clear ( <b>DCL</b> ) and Selected Device Clear ( <b>SDC</b> ) interface commands. They cause the electronic load to clear any activity that would prevent it from receiving and executing a new command (including <b>*WAI</b> and <b>*OPC?</b> ). <b>DCL</b> and <b>SDC</b> do not change any programmed settings.	DCL, SDC

### GPIB Address

The electronic load operates from a GPIB address that is set from the front panel. To set the GPIB address, press the **Address** key on the front panel and enter the address using the Entry keys. The address can be set from 0 to 30. The GPIB address is stored in non-volatile memory.

---

## RS-232 Capabilities of the Electronic Load

The electronic load provides an RS-232 programming interface, which is activated by commands located under the front panel **Address** key. All SCPI commands are available through RS-232 programming. When the RS-232 interface is selected, the GPIB interface is disabled.

The EIA RS-232 Standard defines the interconnections between Data Terminal Equipment (DTE) and Data Communications Equipment (DCE). The electronic load is designed to be a DTE. It can be connected to another DTE such as a PC COM port through a null modem cable.

---

**NOTE:** The RS-232 settings in your program must match the settings specified in the front panel Address menu. Press the front panel **Address** key if you need to change the settings.

---

### RS-232 Data Format

The RS-232 data is a 10-bit word with one start bit and one stop bit. The number of start and stop bits is not programmable. However, the following parity options are selectable using the front panel Address key:

<b>EVEN</b>	Seven data bits with even parity
<b>ODD</b>	Seven data bits with odd parity
<b>MARK</b>	Seven data bits with mark parity (parity is always true)
<b>SPACE</b>	Seven data bits with space parity (parity is always false)
<b>NONE</b>	Eight data bits without parity

Parity options are stored in non-volatile memory.

### Baud Rate

The front panel Address key lets you select one of the following baud rates, which is stored in non-volatile memory:

300      600      1200      2400      4800      9600

### RS-232 Flow Control

The RS-232 interface supports the following flow control options that are selected using the front panel Address key. For each case, the electronic load will send a maximum of five characters after holdoff is asserted by the controller. The electronic load is capable of receiving as many as fifteen additional characters after it asserts holdoff.

<b>RTS-CTS</b>	The electronic load asserts its Request to Send (RTS) line to signal hold-off when its input buffer is almost full, and it interprets its Clear to Send (CTS) line as a hold-off signal from the controller.
<b>NONE</b>	There is no flow control.

Flow control options are stored in non-volatile memory.



## Introduction to SCPI

SCPI (Standard Commands for Programmable Instruments) is a programming language for controlling instrument functions over the GPIB and RS-232 interface. SCPI is layered on top of the hardware-portion of IEEE 488.2. The same SCPI commands and parameters control the same functions in different classes of instruments.

### Conventions Used in This Guide

Angle brackets	< >	Items within angle brackets are parameter abbreviations. For example, <NR1> indicates a specific form of numerical data.
Vertical bar		Vertical bars separate alternative parameters. For example, NORM   TEXT indicates that either "TEXT" or "NORM" can be used as a parameter.
Square Brackets	[ ]	Items within square brackets are optional. The representation [SOURce:]. VOLTage means that SOURce: may be omitted.
Braces	{ }	Braces indicate parameters that may be repeated zero or more times. It is used especially for showing arrays. The notation <A>{<,B>} shows that parameter "A" must be entered, while parameter "B" may be omitted or may be entered one or more times.
Computer font		Computer font is used to show program lines in text. <code>OUTPUT 723 "TRIGger:COUNT:CURRENT 10"</code> shows a program line.

## Types of SCPI Commands

SCPI has two types of commands, common and subsystem.

- ◆ Common commands generally are not related to specific operation but to controlling overall electronic load functions, such as reset, status, and synchronization. All common commands consist of a three-letter mnemonic preceded by an asterisk: \*RST \*IDN? \*SRE 8
- ◆ Subsystem commands perform specific electronic load functions. They are organized into an inverted tree structure with the "root" at the top. The following figure shows a portion of a subsystem command tree, from which you access the commands located along the various paths. You can see the complete tree in Appendix A.

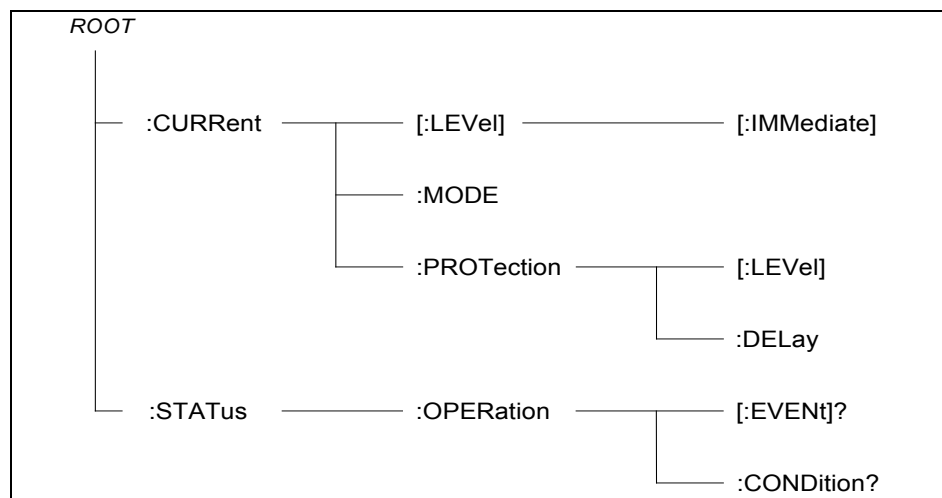

Figure 2-1. Partial Command Tree

## Multiple Commands in a Message

Multiple SCPI commands can be combined and sent as a single message with one message terminator. There are two important considerations when sending several commands within a single message:

- ◆ Use a semicolon to separate commands within a message.
- ◆ There is an implied header path that affects how commands are interpreted by the electronic load.

The header path can be thought of as a string that gets inserted **before** each command within a message. For the first command in a message, the header path is a null string. For each subsequent command the header path is defined as the characters that make up the headers of the previous command in the message up to and including the last colon separator. An example of a message with two commands is:

```
CURR:LEV 3;PROT:STAT OFF
```

which shows the use of the semicolon separating the two commands, and also illustrates the header path concept. Note that with the second command, the leading header "CURR" was omitted because after the "CURR:LEV 3" command, the header path became defined as "CURR" and thus the instrument interpreted the second command as:

```
CURR:PROT:STAT OFF
```

In fact, it would have been syntactically incorrect to include the "CURR" explicitly in the second command, since the result after combining it with the header path would be:

```
CURR:CURR:PROT:STAT OFF
```

which is incorrect.

## Moving Among Subsystems

In order to combine commands from different subsystems, you need to be able to reset the header path to a null string within a message. You do this by beginning the command with a colon (:), which discards any previous header path. For example, you could clear the output protection and check the status of the Operation Condition register in one message by using a root specifier as follows:

```
OUTPut:PROTection:CLEAr::STATus:OPERation:CONDition?
```

The following message shows how to combine commands from different subsystems as well as within the same subsystem:

```
VOLTage:LEVel 20;PROTection 28; :CURRent:LEVel 3;PROTection:STATe ON
```

Note the use of the optional header LEVel to maintain the correct path within the voltage and current subsystems, and the use of the root specifier to move between subsystems.

## Including Common Commands

You can combine common commands with subsystem commands in the same message. Treat the common command as a message unit by separating it with a semicolon (the message unit separator). Common commands *do not affect the header path*; you may insert them anywhere in the message.

```
VOLTage:TRIGgered 17.5;:INITialize;*TRG  
OUTPut OFF;*RCL 2;OUTPut ON
```

## Using Queries

Observe the following precautions with queries:

- ◆ Set up the proper number of variables for the returned data. For example, if you are reading back a measurement array, you must dimension the array according to the number of measurements that you have placed in the measurement buffer.
- ◆ Read back all the results of a query before sending another command to the electronic load. Otherwise a *Query Interrupted* error will occur and the unreturned data will be lost.

---

## Types of SCPI Messages

There are two types of SCPI messages, program and response.

- ◆ A *program message* consists of one or more properly formatted SCPI commands sent from the controller to the electronic load. The message, which may be sent at any time, requests the electronic load to perform some action.
- ◆ A *response message* consists of data in a specific SCPI format sent from the electronic load to the controller. The electronic load sends the message only when commanded by a program message called a "query."

The following figure illustrates SCPI message structure:

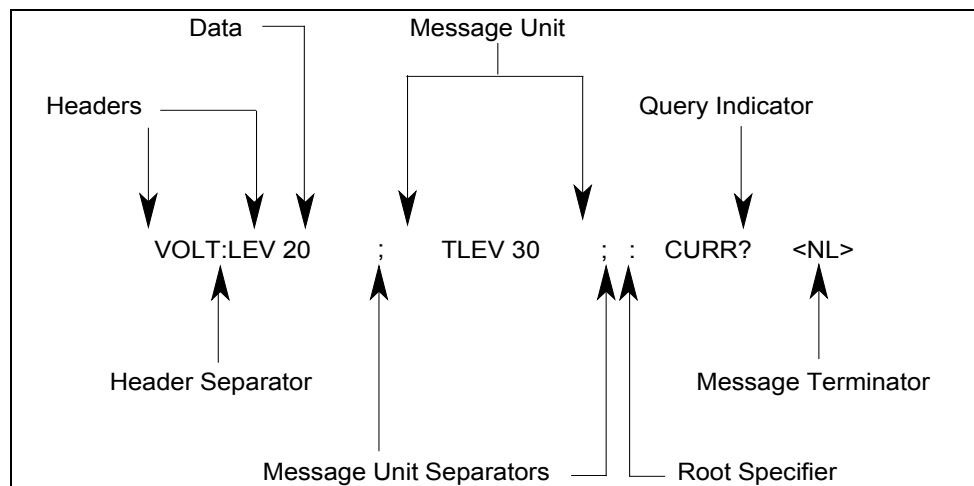

**Figure 2-2. Command Message Structure**

## The Message Unit

The simplest SCPI command is a single message unit consisting of a command header (or keyword) followed by a message terminator. The message unit may include a parameter after the header. The parameter can be numeric or a string.

```
ABORt<NL>
VOLTage 20<NL>
```

## Headers

Headers, also referred to as keywords, are instructions recognized by the electronic load. Headers may be either in the long form or the short form. In the long form, the header is completely spelled out, such as VOLTAGE, STATUS, and DELAY. In the short form, the header has only the first three or four letters, such as VOLT, STAT, and DEL.

## Query Indicator

Following a header with a question mark turns it into a query (VOLTage?, VOLTage:PROTection?). If a query contains a parameter, place the query indicator at the end of the last header (VOLTage:PROTection? MAX).

## Message Unit Separator

When two or more message units are combined into a compound message, separate the units with a semicolon (STATus:OPERation?;QUEStionable?).

## Root Specifier

When it precedes the first header of a message unit, the colon becomes the root specifier. It tells the command parser that this is the root or the top node of the command tree.

## Message Terminator

A terminator informs SCPI that it has reached the end of a message. Three permitted messages terminators are:

- ◆ newline (<NL>), which is ASCII decimal 10 or hex 0A.
- ◆ end or identify (<END>)
- ◆ both of the above (<NL><END>).

In the examples of this guide, there is an assumed message terminator at the end of each message.

---

**NOTE:** All RS-232 response data sent by the electronic load is terminated by the ASCII character pair <carriage return><newline>. This differs from GPIB response data which is terminated by the single character <newline> with EOI asserted.

---

## SCPI Data Formats

All data programmed to or returned from the electronic load is ASCII. The data may be numerical or character string.

### Numerical Data Formats

Symbol	Data Form
	<u>Talking Formats</u>
<NR1>	Digits with an implied decimal point assumed at the right of the least-significant digit. Examples: <b>273</b>
<NR2>	Digits with an explicit decimal point. Example: <b>.0273</b>
<NR3>	Digits with an explicit decimal point and an exponent. Example: <b>2.73E+2</b>
	<u>Listening Formats</u>
<Nrf>	Extended format that includes <NR1>, <NR2> and <NR3>. Examples: <b>273 273. 2.73E2</b>
<Nrf+>	Expanded decimal format that includes <Nrf> and <b>MIN MAX</b> . Examples: <b>273 273. 2.73E2 MAX. MIN</b> and <b>MAX</b> are the minimum and maximum limit values that are implicit in the range specification for the parameter.
<Bool>	Boolean Data. Example: <b>0   1</b> or <b>ON   OFF</b>

## Suffixes and Multipliers

Class	Suffix	Unit	Unit with Multiplier
Amplitude	V	volt	MV (millivolt)
Current	A	ampere	MA (milliampere)
Power	W	watt	MW (milliwatt)
Resistance	OHM	ohm	MOHM (megohm)
Slew Rate	A/s	amps/second	
	R/s	ohms/second	
	V/s	volts/second	
Time	s	second	MS (millisecond)
	<b>Common Multipliers</b>		
	1E3	K	kilo
	1E-3	M	milli
	1E-6	U	micro

## Response Data Types

Character strings returned by query statements may take either of the following forms, depending on the length of the returned string:

- <CRD>** Character Response Data. Permits the return of character strings.
- <AARD>** Arbitrary ASCII Response Data. Permits the return of undelimited 7-bit ASCII. This data type has an implied message terminator.
- <SRD>** String Response Data. Returns string parameters enclosed in double quotes.

---

## SCPI Command Completion

SCPI commands sent to the electronic load are processed either sequentially or in parallel. Sequential commands finish execution before a subsequent command begins. Parallel commands allow other commands to begin executing while the parallel command is still executing. Commands that affect trigger actions are among the parallel commands.

The `*WAI`, `*OPC`, and `*OPC?` common commands provide different ways of indicating when all transmitted commands, including any parallel ones, have completed their operations. The syntax and parameters for these commands are described in chapter 4. Some practical considerations for using these commands are as follows:

- `*WAI` This prevents the electronic load from processing subsequent commands until all pending operations are completed.
- `*OPC?` This places a 1 in the Output Queue when all pending operations have completed. Because it requires your program to read the returned value before executing the next program statement, `*OPC?` can be used to cause the controller to wait for commands to complete before proceeding with its program.
- `*OPC` This sets the OPC status bit when all pending operations have completed. Since your program can read this status bit on an interrupt basis, `*OPC` allows subsequent commands to be executed.

---

**NOTE:** The trigger system must be in the Idle state in order for the status OPC bit to be true. Therefore, as far as triggers are concerned, OPC is false whenever the trigger system is in the Initiated state.

---

## Using Device Clear

You can send a device clear at any time to abort a SCPI command that may be hanging up the GPIB interface. The status registers, the error queue, and all configuration states are left unchanged when a device clear message is received. Device clear performs the following actions:

- ◆ The input and output buffers of the electronic load are cleared.
- ◆ The electronic load is prepared to accept a new command string.

The following statement shows how to send a device clear over the GPIB interface using *GW BASIC*:

```
CLEAR 705          IEEE-488 Device Clear
```

The following statement shows how to send a device clear over the GPIB interface using the GPIB command library for *C* or *QuickBASIC*:

```
IOCLEAR (705)
```

---

**NOTE:** For RS-232 operation, sending a Break will perform the same operation as the IEEE-488 device clear message.

---

---

## RS-232 Troubleshooting

If you are having trouble communicating over the RS-232 interface, check the following:

- ◆ The computer and the electronic load must be configured for the same baud rate, parity, number of data bits, and flow control options. Note that the electronic load is configured for 1 start bit and 1 stop bit (these values are fixed).
- ◆ The correct interface cables or adapters must be used, as described under RS-232 Connector. Note that even if the cable has the proper connectors for your system, the internal wiring may be incorrect.
- ◆ The interface cable must be connected to the correct serial port on your computer (COM1, COM2, etc.).

## SCPI Conformance Information

### SCPI Conformed Commands

The Electronic Load conforms to SCPI Version 1995.0.

ABOR	MEAS   FETC[:SCAL]:VOLT:MAX	[SOUR]:RES[:LEV][:IMM][:AMP]
CAL:DATA	MEAS   FETC[:SCAL]:VOLT:MIN	[SOUR]:RES[:LEV]:TRIG[:AMP]
CAL:STAT	SENS:CURR[:DC]:RANG[:UPP]	[SOUR]:RES:MODE
INIT[:IMM]:SEQ	SENS:SWE:OFFS	[SOUR]:RES:RANG
INIT[:IMM]:NAME	SENS:SWE:POIN	[SOUR]:RES:SLEW
INIT:CONT:SEQ	SENS:SWE:TINT	[SOUR]:VOLT[:LEV][:IMM][:AMP]
INIT:CONT:NAME	SENS:WIND[:TYPE]	[SOUR]:VOLT[:LEV]:TRIG[:AMP]
INP   OUTP[:STAT]	SENS:VOLT[:DC]:RANG[:UPP]	[SOUR]:VOLT:MODE
INP   OUTP:PROT:CLE	[SOUR]:CURR[:LEV][:IMM][:AMP]	[SOUR]:VOLT:RANG
MEAS   FETC:ARR:CURR[:DC]	[SOUR]:CURR[:LEV]:TRIG[:AMP]	[SOUR]:VOLT:SLEW
MEAS   FETC:ARR:POW[:DC]	[SOUR]:CURR:MODE	STAT:OPER[:EVEN]
MEAS   FETC:ARR:VOLT[:DC]	[SOUR]:CURR:PROT[:LEV]	STAT:OPER:COND
MEAS   FETC[:SCAL]:CURR[:DC]	[SOUR]:CURR:PROT:STAT	STAT:OPER:ENAB
MEAS   FETC[:SCAL]:CURR:MAX	[SOUR]:CURR:RANG	STAT:OPER:NTR
MEAS   FETC[:SCAL]:CURR:MIN	[SOUR]:CURR:SLEW	STAT:OPER:PTR
MEAS   FETC[:SCAL]:POW[:DC]	[SOUR]:LIST:COUN	STAT:QUES[:EVEN]
MEAS   FETC[:SCAL]:POW:MAX	[SOUR]:LIST:CURR	STAT:QUES:COND
MEAS   FETC[:SCAL]:POW:MIN	[SOUR]:LIST:DWEL	STAT:QUES:ENAB
MEAS   FETC[:SCAL]:VOLT[:DC]	[SOUR]:LIST:RES	SYST:ERR
	[SOUR]:LIST:VOLT	SYST:VER

### Non-SCPI Commands

CAL:IMON:LEV	[SOUR]:LIST:CURR:TLEV	[SOUR]:TRAN[:STAT]
CAL:IPR:LEV	[SOUR]:LIST:FUNC   MODE	[SOUR]:TRAN:DCYC
CAL:LEV	[SOUR]:LIST:RES:RANG	[SOUR]:TRAN:FREQ
CAL:PASS	[SOUR]:LIST:RES:SLEW[:BOTH]	[SOUR]:TRAN:MODE
CAL:SAVE	[SOUR]:LIST:RES:SLEW:NEG	[SOUR]:TRAN:LMOD
CHAN   INST[:LOAD]	[SOUR]:LIST:RES:SLEW:POS	[SOUR]:TRAN:TWID
INP   OUTP:SHOR[:STAT]	[SOUR]:LIST:RES:TLEV	[SOUR]:VOLT:SLEW:NEG
MEAS   FETC[:SCAL]:CURR:ACDC	[SOUR]:LIST:STEP	[SOUR]:VOLT:SLEW:POS
MEAS   FETC[:SCAL]:VOLT:ACDC	[SOUR]:LIST:TRAN[:STAT]	[SOUR]:VOLT:TLEV
PORT0[:STAT]	[SOUR]:LIST:TRAN:DCYC	STAT:CHAN[:EVEN]
PORT1[:LEV]	[SOUR]:LIST:TRAN:FREQ	STAT:CHAN:COND
[SOUR]:CURR:PROT:DEL	[SOUR]:LIST:TRAN:MODE	STAT:CHAN:ENAB
[SOUR]:CURR:SLEW:NEG	[SOUR]:LIST:TRAN:TWID	STAT:CSUM[:EVEN]
[SOUR]:CURR:SLEW:POS	[SOUR]:LIST:VOLT:RANG	STAT:CSUM:ENAB
[SOUR]:CURR:TLEV	[SOUR]:LIST:VOLT:SLEW[:BOTH]	SYST:LOC
[SOUR]:FUNC   MODE	[SOUR]:LIST:VOLT:SLEW:NEG	SYST:REM
[SOUR]:FUNC   MODE:MODE	[SOUR]:LIST:VOLT:SLEW:POS	SYST:RWL
[SOUR]:LIST:CURR:RANG	[SOUR]:LIST:VOLT:TLEV	TRIG[:IMM]
[SOUR]:LIST:CURR:SLEW[:BOTH]	[SOUR]:RES:SLEW:NEG	TRIG:DEL
[SOUR]:LIST:CURR:SLEW:NEG	[SOUR]:RES:SLEW:POS	TRIG:SOUR
[SOUR]:LIST:CURR:SLEW:POS	[SOUR]:RES:TLEV	TRIG:TIM
		TRIG:SEQ2:COUN





# Programming Examples

---

## Introduction

This chapter contains examples on how to program your electronic load. Simple examples show you how to program:

- ◆ Input functions such as voltage, current, and resistance
- ◆ Transient functions, including lists
- ◆ Measurement functions
- ◆ The status and protection functions

---

**NOTE:** These examples in this chapter show which commands are used to perform a particular function, but do not show the commands being used in any particular programming environment.

---

## Programming the Input

### Power-on Initialization

When the electronic load is first turned on, it wakes up with the input state set OFF. The following commands are given implicitly at power-on:

```
*RST
*CLS
*SRE 0
*ESE 0
```

\*RST is a convenient way to program all parameters to a known state. Refer to the \*RST command in chapter 4 to see how each programmable parameter is set by \*RST. Refer to the \*PSC command in chapter 4 for more information on the power-on initialization of the \*ESE and the \*SRE registers.

### Enabling the Input

To enable the input, use the command:

```
INPut ON
```

### Input Voltage

The input voltage is controlled with the VOLTage command. For example, to set the input voltage to 25 volts, use:

```
VOLTage 25
```

### 3 - Programming Examples

#### Maximum Voltage

The maximum input voltage that can be programmed can be queried with:

```
VOLTage? MAXimum
```

#### Input Current

All models have a programmable current function. The command to program the current is:

```
CURRent <n>
```

where <n> is the input current in amperes.

#### Maximum Current

The maximum input current that can be programmed can be queried with:

```
CURRent? MAXimum
```

#### Overcurrent Protection

The electronic load can also be programmed to turn off its input if the current protection level is reached. As explained in chapter 4, this protection feature is implemented the following command:

```
CURRent:PROTection:STATe ON | OFF
```

---

**NOTE:** Use `CURRent:PROTection:DELay` to prevent momentary current limit conditions caused by programmed input changes from tripping the overcurrent protection.

---

#### Setting the Triggered Voltage or Current Levels

To program voltage or current triggered levels, you must specify the voltage or current level that the input will go to once a trigger signal is received. Use the following commands to set a triggered level:

```
VOLTage:TRIGgered <n> or  
CURRent:TRIGgered <n>
```

---

**NOTE:** Until they are explicitly programmed, triggered levels will assume their corresponding immediate levels. For example, if a electronic load is powered up and `VOLTage:LEVel` is programmed to 6, then `VOLTage:LEVel:TRIGger` will also be 6 until you program it to another value. Once you program `VOLTage:LEVel:TRIGger` to a value, it will remain at that regardless of how you subsequently reprogram `VOLTage:LEVel`. Then, when the trigger occurs, the `VOLTage:LEVel` is set to the `VOLTage:LEVel:TRIGger` value.

---

#### Generating Triggers

You can generate a single trigger by sending the following command over the GPIB:

```
TRIGger:IMMediate
```

Note that this command will always generate a trigger. Use the `TRIGger:SOURce` command to select other trigger sources such as the mainframe's external trigger input.

## Programming Transients

Transient operation is used to synchronize input changes with internal or external trigger signals, and simulate loading conditions with precise control of timing, duration, and slew. The following transient modes can be generated:

<b>Continuous</b>	Generates a repetitive pulse stream that toggles between two load levels.
<b>Pulse</b>	Generates an load change that returns to its original state after some time period.
<b>Toggled</b>	Generates a repetitive pulse stream that toggles between two load levels. Similar to Continuous mode except that the transient points are controlled by explicit triggers instead of an internal transient generator.

**NOTE:** Before turning on transient operation, set the desired mode of operation as well as all of the parameters associated with transient operation. At \*RST all transient functions are set to OFF.

### Continuous Transients

In continuous operation, a repetitive pulse train switches between two load levels, a main level (which can be either the immediate or triggered level) and a transient level. The rate at which the level changes is determined by the slew rate (see slew rate descriptions for CV, CR, or CV mode as applicable). In addition, the frequency and duty cycle of the continuous pulse train are programmable. Use the following commands to program continuous transients:

```

TRANSient:MODE CONTinuous
CURRent 5
CURRent:TLEVel 10
TRANSient:FREQuency 1000
TRANSient:DCYClE 40
TRANSient ON

```

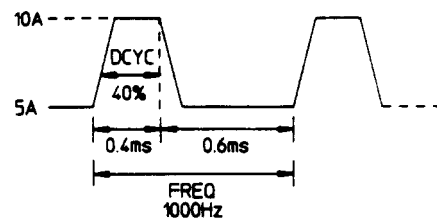

This example assumes that the CC mode is active and the slew rate is at the default setting (maximum rate). The load module starts conduction at the main level (in this case 5 amps). When transient operation is turned on (no trigger is required in continuous mode), the module input current will slew to and remain at 10 amps for 40% of the period (400  $\mu$ s). The input current will then slew to and remain at 5 amps for the remaining 60% (600  $\mu$ s) of that cycle.

### Pulse Transients

Pulsed transient operation generates a load change that returns to its original state after some time period. It is similar to continuous operation with the following exceptions:

- To get a pulse, an explicit trigger is required. To specify the trigger source, use TRIGger:SOURce. See "Triggering Transients".
- One pulse results from each trigger. Therefore, frequency cannot be programmed.

Use the following commands to program pulsed transients:

### 3 - Programming Examples

```
TRIGger:SOURce EXTernal
TRANsient:MODE PULSe
CURRent 5
CURRent:TLEVel 10
TRANsient:TWIDth .01
TRANsient ON
```

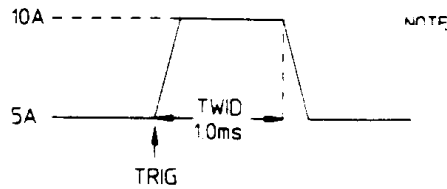

This example assumes that the CC mode is active, the slew rate is at the factory default setting (maximum rate), and a trigger signal is connected to the mainframe's external trigger input. The load module starts conduction at the main current level setting (5 amps). When the transient mode is turned on and an external trigger signal is received, the input level starts increasing at a rate determined by the slew rate. When the value specified by the transient level setting (10 amps) is reached, it stays there for the remainder of the time determined by the pulse width setting (10 milliseconds). After this time has elapsed, the input level decreases to the main level again at the rate specified by the slew setting and remains there until another trigger is received. Any triggers that occur during the time the transient level is in effect will re-trigger the pulse, extending the pulse by another pulse-width value.

### Toggled Transients

Toggled transient operation causes the module input to alternate between two pre-defined levels as in continuous operation except that the transient transitions are controlled by explicit triggers instead of the internal transient generator. See "Triggering Transients". Use the following commands to program toggled transients:

```
TRIGger:SOURce EXTernal
TRANsient:MODE TOGgle
CURRent 5
CURRent:TLEVel 10
TRANsient ON
```

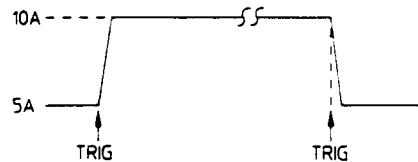

This example assumes that the CC mode is active, the slew rate is at the factory default setting (maximum rate), and a trigger signal is connected to the mainframe's external trigger input. Toggled transient operation is similar to that described for continuous and pulse operation, except that each time a trigger is received the input alternates between the main and transient input current levels.

---

## Programming Lists

List mode lets you generate complex sequences of input changes with rapid, precise timing, which may be synchronized with internal or external signals. This is useful when running test sequences with a minimum amount of programming overhead.

You can program up to 50 settings (or steps) in the list, the time interval (dwell) that each setting is maintained, the number of times that the list will be executed, and how the settings change in response to triggers. All list data can be stored in nonvolatile memory when saved in locations 0, 7, 8, or 9 using the \*SAV command. This means that the programmed data for any list will be retained when the electronic load is turned off. Use the \*RCL command to recall the saved state. \*RST clears the presently active list but will not clear the lists saved in locations 0, 7, 8, or 9.

List steps can be either individually triggered, or paced by a separate list of dwell times that define the duration of each step. Therefore, each of the up to 50 steps has an associated dwell time, which specifies the time (in seconds) that the input remains at that step before moving on to the next step. The following procedure shows how to generate a simple 9-step list of current and voltage changes.

**Step 1** Set the mode of each function that will participate in the sequence to LIST. For example:

```
CURRent:MODE LIST
```

**Step 2** Program the list of input values for each function. The list commands take a comma-separated list of arguments. The order in which the arguments are given determines the sequence in which the values will be input. For example, to vary the input current of the electronic load to simulate a 25%, 50%, and 100% load, a list may include the following values:

```
LIST:CURRent[:LEVel] 15, 30, 60, 15, 30, 60, 15, 30, 60
```

You must specify a list for all current functions, whether or not the functions will be used. For example, to synchronize the previous current list with another list that varies the slew rate from 0.01A/μs, to 0.1A/μs, to 1A/μs (programmed in A/s), the lists may include the following values:

```
LIST:CURRent[:LEVel] 15, 30, 60, 15, 30, 60, 15, 30, 60
LIST:CURRent:SLEW 1E+5, 1E+5, 1E+5, 1E+6, 1E+6, 1E+6, 1E+7, 1E+7, 1E+7
LIST:CURRent:RANGe 60
LIST:CURRent:TLEVel 0
```

All lists must have the same number of data values or points, or an error will occur when the list system that starts the sequence is initiated. The exception is when a list has only one item or point. In this case the single-item list is treated as if it had the same number of points as the other lists, with all values being equal to the one item. For example:

```
LIST:CURRent 15, 30, 45, 60;SLEW 1E+6
```

is the same as:

```
LIST:CURRent 15, 30, 45, 60
LIST:CURRent:SLEW 1E+6, 1E+6, 1E+6, 1E+6
```

**Step 3** Determine the time interval that the input remains at each level or point in the list before it advances to the next point. The time is specified in seconds. For example, to specify five dwell intervals, use:

```
LIST:DWELL 1, 1.5, 2, 2.5, 3
```

The number of dwell points must equal the number of input points. If a dwell list has only one value, that value will be applied to all points in the input list.

**Step 4** Determine the number of times the list is repeated before it completes. For example, to repeat a list 10 times use:

```
LIST:COUNT 10
```

Entering INFinity makes the list repeat indefinitely. At \*RST, the count is set to 1.

**Step 5** Determines how the list sequencing responds to triggers. For a closely controlled sequence of input levels, you can use a dwell-paced list. To cause the list to be paced by dwell time use:

```
LIST:STEP AUTO
```

As each dwell time elapses, the next point is immediately input. This is the \*RST setting.

If you need the input to closely follow asynchronous events, then a trigger-paced list is more appropriate. In a trigger-paced list, the list advances one point for each trigger received. To enable trigger-paced lists use:

```
LIST:STEP ONCE
```

The dwell time of each point determines the minimum time that the input remains at that point. If a trigger is received before the previous dwell time completes, the trigger is ignored. Therefore, to ensure that no triggers are lost, program the dwell time to "MIN".

**Step 6** Use the list trigger system to trigger the list. See "Triggering Transients and Lists".

## Programming Lists for Multiple Channels

You can program separate lists for individual channels on a load mainframe. Once lists have been programmed for each channel, they can all be triggered at the same time using the list trigger system.

---

**NOTE:** All lists must have the same number of data values or points, or an error will occur when the list system that starts the sequence is initiated.

---

**Step 1** Select the channel for which you want to program the list. All subsequent list commands will be sent to this channel until another channel is selected.

```
CHANnel 1
```

**Step 2** Program the list of values for each function for that channel. The list commands take a comma-separated list of arguments. For example:

```
LIST:CURRENT 15, 30, 60, 15, 30, 60, 15, 30, 60
LIST:CURRENT:SLEW 1E+5, 1E+5, 1E+5, 1E+6, 1E+6, 1E+6, 1E+7, 1E+7, 1E+7
.
```

Add other list functions.

**Step 3** Select the next channel for which you want to program a list. All subsequent list commands will now be sent to this channel.

```
CHANnel 2
```

**Step 4** Program the list of values for each function for that channel. You can program different functions for each channel, however all functions must have the same number of steps

```
LIST:VOLTage 30, 60, 30, 30, 60, 30, 30, 60, 30
LIST:VOLTage:SLEW 1E+5, 1E+5, 1E+5, 1E+6, 1E+6, 1E+6, 1E+7, 1E+7, 1E+7
.
```

Add other list functions. You do not have to program the same number of functions for each channel.

**Step 5** Repeat steps 3 and 4 for any other channel that you wish to program.

**Step 6** Use the list trigger system to trigger the list. This is described under "Triggering Transients and Lists".

## Triggering Transients and Lists

Continuous, pulse, and toggled transient modes respond to triggers as soon as the trigger is received. This is not the case for lists. Lists have an independent trigger system that is similar to the measurement trigger system. This section describes the list trigger system. The measurement trigger system is described under "Triggering Measurements".

### SCPI Triggering Nomenclature

In SCPI terms, trigger systems are called sequences. When more than one trigger system exists, they are differentiated by naming them SEQUENCE1 and SEQUENCE2. SEQUENCE1 is the list trigger system and SEQUENCE2 is the measurement trigger system. The electronic load uses aliases with more descriptive names for these sequences. These aliases can be used instead of the sequence forms.

Sequence Form	Alias
SEQUENCE1	LIST
SEQUENCE2	ACQUIRE

### List Trigger Model

Figure 3-3 is a model of the list trigger system. The rectangles represent states. The arrows show the transitions between states. These are labeled with the input or event that causes the transition to occur.

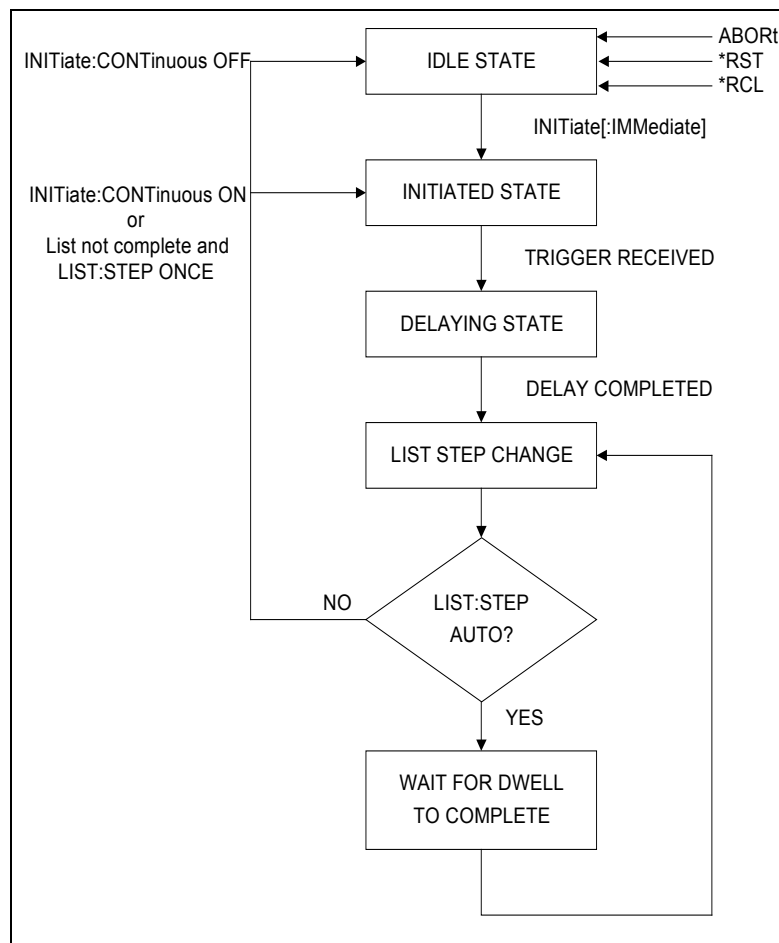

Figure 3-3. Model of List Triggers

### 3 - Programming Examples

#### Initiating List Triggers

When the electronic load is turned on, the list trigger system is in the idle state. In this state, the list system ignores all triggers. Sending the following commands at any time returns the list system to the Idle state:

```
ABORT  
*RST  
*RCL
```

The INITiate commands move the list system from the Idle state to the Initiated state. This enables the list system to receive triggers. INITiate commands are not channel-specific, they affect all installed load modules. To initiate the list system for a single triggered action, use:

```
INITiate:SEQuence1 or  
INITiate:NAME LIST
```

---

**NOTE:** Whenever a list is initiated or triggered, the  $\phi 1$  annunciator is lit on the front panel.

---

After a trigger is received and the action completes, the list system will return to the Idle state. Thus it will be necessary to initiate the list system each time a triggered action is desired.

To keep the list system initiated for multiple actions without having to send an Initiate command for each trigger, use:

```
INITiate:CONTinuous:SEQuence1 ON or  
INITiate:CONTinuous:NAME LIST, ON
```

#### Specifying a Trigger Delay

A time delay can be programmed between the receipt of the trigger system and the start of the triggered action. This delay applies to both list and measurement triggers. At \*RST the trigger delay is set to 0, which means there is no trigger delay. To program a trigger delay use:

```
TRIGger:DElay <n>
```

#### Generating Transient and List Triggers

Use one of the following triggering methods to generate transients and lists:

```
TRIGger:SOURce BUS | EXTernal | HOLD | LINE | TIMer
```

After you have specified the appropriate trigger source, you can generate triggers as follows:

<b>Single triggers over the bus</b>	Send one of the following commands over the GPIB: TRIGger:IMMediate *TRG a group execute trigger
<b>Continuous triggers synchronized with the ac line frequency</b>	Send the following command over the GPIB: TRIGger:SOURce LINE
<b>Continuous triggers synchronized with the internal timer</b>	Send the following commands over the GPIB: TRIGger:TIMer <time> TRIGger:SOURce TIMer
<b>External trigger</b>	Apply a high to low signal to the external trigger input at the back of the mainframe.



---

## Making Measurements

The electronic load has the ability to make several types of voltage or current measurements. The measurement capabilities of the electronic load are particularly useful with applications that draw current in pulses.

All measurements are performed by digitizing the instantaneous input voltage or current for a defined number of samples and sample interval, storing the results in a buffer, and then calculating the measured result. Many parameters of the measurement are programmable. These include the number of samples, the time interval between samples, and the method of triggering. Note that there is a tradeoff between these parameters and the speed, accuracy, and stability of the measurement in the presence of noise.

There are two ways to make measurements:

- ◆ Use the MEASure commands to immediately start acquiring new voltage or current data, and return measurement calculations from this data as soon as the buffer is full. This is the easiest way to make measurements, since it requires no explicit trigger programming.
- ◆ Use an acquisition trigger to acquire the data. Then use the FETCh commands to return calculations from the data that was retrieved by the acquisition trigger. This method gives you the flexibility to synchronize the data acquisition with a trigger. FETCh commands do not trigger the acquisition of new measurement data, but they can be used to return many different calculations from the data that was retrieved by the acquisition trigger.

Making triggered measurements with the acquisition trigger system is discussed under "Triggering Measurements".

---

**NOTE:** For each MEASure form of the query, there is a corresponding query that begins with the header FETCh. FETCh queries perform the same calculation as their MEASure counterparts, but do not cause new data to be acquired. Data acquired by an explicit trigger or a previously programmed MEASure command are used.

---

## Voltage and Current Measurements

The SCPI language provides a number of MEASure and FETCh queries, which return various measurement parameters of voltage and current waveforms.

### DC Measurements

To measure the dc input voltage or current, use:

```
MEASure:VOLTage? or
MEASure:CURRent?
```

DC voltage and current is measured by acquiring a number of readings at the selected time interval, optionally applying a Hanning window function to the readings, and averaging the readings. Windowing is a signal conditioning process that reduces the error in dc measurements made in the presence of periodic signals such as line ripple. At power-on and after a \*RST command, the following parameters are set:

```
SENSe:SWEEp:TINTerval 10E-6
SENSe:SWEEp:POINTs 1000
```

This results in a data acquisition time of 10 milliseconds. Adding a command processing overhead of about 20 milliseconds results in a total measurement time of about 30 milliseconds per measurement sample.

### 3 - Programming Examples

Ripple rejection is a function of the number of cycles of the ripple frequency contained in the acquisition window. More cycles in the acquisition window results in better ripple rejection. If you increase the time interval for each measurement to 45 microseconds for example, this results in 5.53 cycles in the acquisition window at 60 Hz, for a ripple rejection of about 70 dB.

Note that the processing overhead time will vary, depending on the number of measurement samples. If you reduce the number of sample points, you will also reduce the command processing overhead. If you increase the number of sample point (up to a maximum of 4096) you increase the command processing overhead.

#### **RMS Measurements**

To read the rms content of a voltage or current waveform, use:

```
MEASure:VOLTage:ACDC? or  
MEASure:CURRent:ACDC?
```

This returns the total rms measurement, including the dc portion.

#### **Minimum and Maximum Measurements**

To measure the maximum or minimum voltage or current of a pulse or ac waveform, use:

```
MEASure:VOLTage:MAXimum?  
MEASure:VOLTage:MINimum?  
MEASure:CURRent:MAXimum?  
MEASure:CURRent:MINimum?
```

#### **Measurement Ranges**

The electronic load has two current and two voltage measurement ranges. The commands that control the measurement ranges are:

```
SENSe:CURRent:RANGe MIN | MAX  
SENSe:VOLTage:RANGe MIN | MAX
```

When the range is set to MAX, the maximum current or voltage that can be measured is a function of the current and voltage rating of the load module that is being programmed (see Table 4-1).

#### **Returning Measurement Data From the Data Buffer**

The MEASure and FETCh queries can also return all data values of the instantaneous voltage or current buffer. The commands are:

```
FETCh:ARRay:CURRent?  
FETCh:ARRay:VOLTage?
```

This is a useful feature if, for example, you have entered multiple measurements into the buffer as a result of measuring the response to a triggered list. Data is returned from the buffer in the same order in which it was entered into the buffer. Refer to "Synchronizing Transients and Measurements" for more information.

## Triggering Measurements

You can use the data acquisition trigger system to synchronize the timing of the voltage and current data acquisition with a trigger source. Then use the FETCh commands to return different calculations from the data acquired by the measurement trigger.

### SCPI Triggering Nomenclature

In SCPI terms, trigger systems are called sequences. When more than one trigger system exists, they are differentiated by naming them SEQUENCE1 and SEQUENCE2. SEQUENCE1 is the list trigger system and SEQUENCE2 is the measurement trigger system. The electronic load uses aliases with more descriptive names for these sequences. These aliases can be used instead of the sequence forms.

Sequence Form	Alias
SEQUENCE2	ACQUIRE

### Measurement Trigger Model

Figure 3-1 is a model of the measurement trigger system. The rectangular boxes represent states. The arrows show the transitions between states. These are labeled with the input or event that causes the transition to occur.

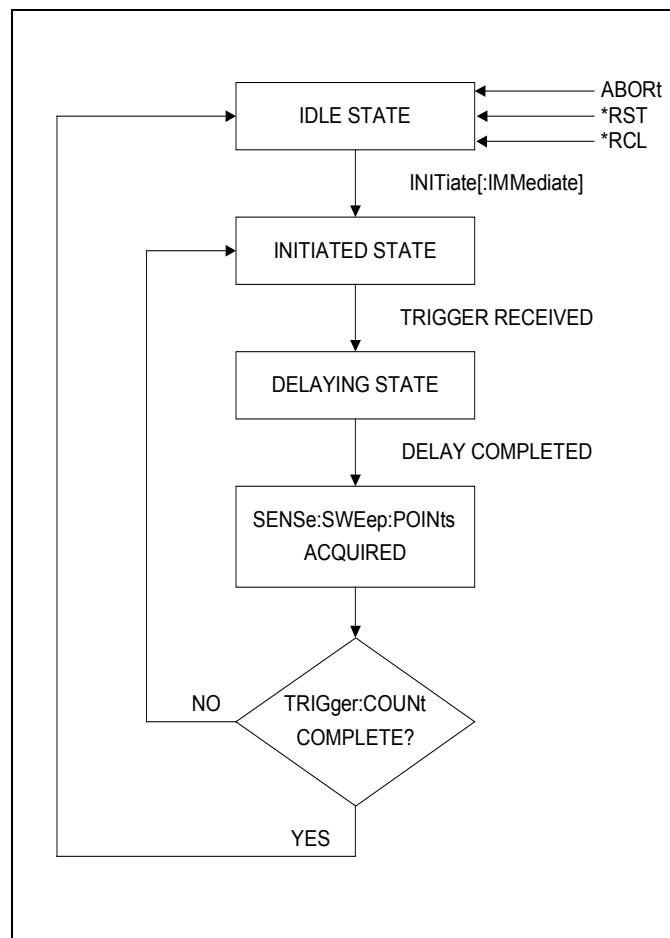

Figure 3-1. Model of Measurement Triggers

## Initiating the Measurement Trigger System

When the electronic load is turned on, the trigger system is in the idle state. In this state, the trigger system ignores all triggers. Sending the following commands at any time returns the trigger system to the Idle state:

```
ABORt
*RST
*RCL
```

The INITiate commands move the trigger system from the Idle state to the Initiated state. This enables the electronic load to receive triggers. INITiate commands are not channel-specific, they affect all installed load modules. To initiate a measurement trigger, use:

```
INITiate:SEQuence2    or
INITiate:NAME ACQuire
```

After a trigger is received and the data acquisition completes, the trigger system will return to the Idle state unless multiple measurements are programmed using the TRIGger:SEQuence2:COUnT command. Thus it will be necessary to initiate the system each time a triggered acquisition is desired.

---

**NOTE:** You cannot initiate measurement triggers continuously. Otherwise, the measurement data in the data buffer would continuously be overwritten.

---

## Generating Measurement Triggers

Use one of the following triggering methods to generate measurements:

```
TRIGger:SOURce BUS | EXTernal | HOLD | LINE | TIMer
```

After you have specified the appropriate source, you can generate measurement triggers as follows:

<b>Single triggers over the bus</b>	Send one of the following commands over the GPIB: <pre>TRIGger:IMMediate (this overrides TRIG:SOUR HOLD) *TRG a group execute trigger</pre>
<b>Continuous triggers synchronized with the ac line frequency</b>	Send the following command over the GPIB: <pre>TRIGger:SOURce LINE</pre>
<b>Continuous triggers synchronized with the internal timer</b>	Send the following commands over the GPIB: <pre>TRIGger:TIMer &lt;time&gt; TRIGger:SOURce TIMer</pre>
<b>External trigger</b>	Apply a low to high signal to the external trigger input at the back of the mainframe.

When the acquisition finishes, any of the FETCh queries can be used to return the results. Once the measurement trigger is initiated, if a FETCh query is sent before the data acquisition is triggered or before it is finished, the response data will be delayed until the trigger occurs and the acquisition completes. This may tie up the controller if the trigger condition does not occur immediately.

One way to wait for results without tying up the controller is to use the SCPI command completion commands. For example, you can send the \*OPC command after INITialize, then occasionally poll the OPC status bit in the standard event status register for status completion while doing other tasks. You can also set up an SRQ condition on the OPC status bit going true, and do other tasks until an SRQ interrupt occurs.

## Controlling Measurement Samples

### Varying the Sampling Rate

You can vary both the number of data points in a measurement sample, as well as the time between samples. You can also specify a delay from the trigger to the start of the measurement. This is illustrated in the following figure.

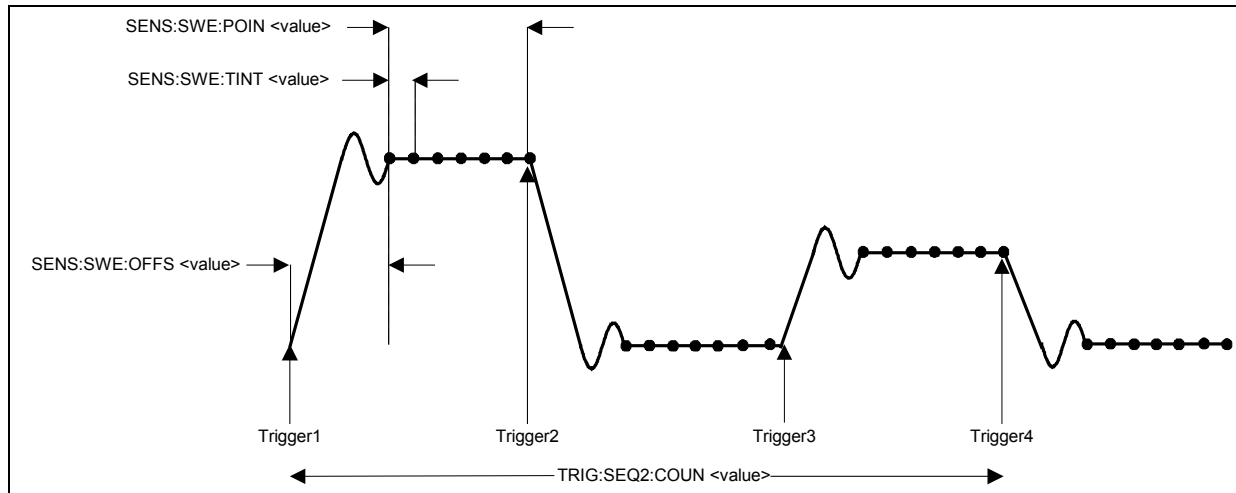

**Figure 3-2. Sense Commands Used to Vary the Sampling Rate**

At power-on, the input voltage and current sampling rate is 10 microseconds. This means that, not accounting for the command processing overhead, it takes about 41 milliseconds to fill up 4096 data points in the data buffer. You can vary this data sampling rate with:

```
SENSe:SWEep:TINTerval <sample_period>
SENSe:SWEep:POINTs <points>
```

For example, to set the time interval to 50 microseconds per sample with 500 samples, use:

```
SENSe:SWEep:TINTerval 50E-6;POINTs 500.
```

### Measurement Delay

You can delay the start of a measurement in relation to the trigger. This is useful if you do not want to start taking measurements at the beginning of an input transient or list step during the time that the input voltage or current is still slewing or settling into its programmed value. To offset the measurement from the beginning of the input transient or list step, use:

```
SENSe:SWEep:OFFSet 10E-3
```

In this example, the measurement occurs 10 milliseconds after the start of the trigger. The offset can be set to a negative value, but this number cannot exceed the TRIGger:DELay value.

### Multiple Measurements

The electronic load also has the ability to set up several acquisition triggers in succession and concatenate the results from each acquisition in the measurement buffer. This is useful for making measurements from lists. To set up the trigger system for a number of sequential acquisitions use:

```
TRIGger:SEQuence2:COUNT <number>
```

### 3 - Programming Examples

With this setup, the instrument performs each acquisition sequentially, storing the digitized readings in the internal measurement buffer. A trigger signal is required to make each measurement. It is only necessary to initialize the measurement once at the start; after each completed acquisition the instrument will wait for the next valid trigger condition to start another. The results returned by MEASure or FETCh will be the *average* of the total data acquired.

If you do not want the instrument to average the acquisition data, use the FETCh:ARRay commands to return the raw data from the voltage or current measurement buffer.

---

**NOTE:** The total number of data points cannot exceed 4096. This means that the trigger count multiplied by the number of points cannot exceed 4096; otherwise an error will occur.

---

## Synchronizing Transients and Measurements

The transient and measurement systems are independent of each other. However, it is possible to synchronize the two systems through the use of triggers. This is because when both transient and measurement systems have been initialized, the same trigger signal will affect both systems. For example, you may have an application where you need to measure the effects of a list step.

### Measuring Triggered Transients or Lists

Measuring triggered transients or lists is generally a straightforward process because you are using the same trigger to generate the output transient and simultaneously take the measurement. The following example illustrates how to make measurements from a simple 3-step trigger paced list. Each list step has a duration of two seconds. Each step-measurement consists of three data points with an offset of 100 milliseconds.

**Step 1** Set the mode of each function that will participate in the sequence to LIST. For example:

```
CURRent:MODE LIST
```

**Step 2** Program the list of input values for each function.

```
LIST:CURRent 15, 30, 60
LIST:CURRent:SLEW 1E+6, 1E+6, 1E+6
LIST:CURRent:RANGe 60
LIST:CURRent:TLEVel 0
```

**Step 3** Specify the number of triggered measurements that will be taken.

```
TRIGger:SEQuence2:COUNT 3
```

The number of measurements should match the number of steps in the list.

**Step 4** Specify the time interval and the number of points in each triggered measurement.

```
SENSe:SWEEp:TINTerval 100E-3
SENSe:SWEEp:POINTs 3
```

In this example, three measurements or data points are taken at each list step, separated by 100ms intervals. Make sure that all of the measurement samples complete within the step time interval. If another trigger occurs while a measurement is in progress, the measurement system will ignore the trigger. Also note that the number of data points specified in this step multiplied by the measurement count specified in step 3 cannot exceed 4096.

**Step 5** Specify a delay time from the start of the trigger until the measurement is taken.

```
SENSe:SWEEp:OFFset 100E-6
```

This specifies the offset in seconds, in this case, 100 microseconds

**Step 6** Initiate both the transient (list) and the measurement trigger systems.

```
INITiate:SEQuence1
INITiate:SEQuence2
```

**Step 7** Specify the trigger source and the timing that will control the list steps and the measurements.

```
TRIGger:TIMer 2
TRIGger:SOURce TIMer
```

In this example the trigger source is the internal trigger. Because the internal timer starts running as soon as the TRIGger:SOURce:TIMer command is executed, the trigger that starts the list and measurement will not occur until the **end** of the two-second timer window within which the trigger is received. After the initial trigger occurs, the list will remain at each step for two seconds before the next trigger occurs.

**Step 8** Return the current measurements from the data array. In this case, a total of nine measurements were taken, three at each list step. To return the measurement data you must first dimension an array, then fetch the data.

```
Dimension an array here
FETch:CURRent:ARRay ARRAY1
```

---

**NOTE:** Each load module retains its measurement data. If multiple lists have been executed, you must select each channel in turn, and fetch the measurement data from that channel.

---

## Measuring Dwell-Paced Lists

The main difference between a trigger-paced list and a dwell-paced list is that *no* triggers occur between steps in a dwell-paced list. Only one measurement will be taken during the time the list is executed. Therefore, to capture measurement data for the entire time the list is executed, the total measurement time of a dwell paced list (time interval X number of points) must equal the total dwell time of the list.

**Step 1** Program the list as previously described under "Measuring Triggered Transients or Lists."

**Step 2** Specify a dwell time for each list step. For example:

```
LIST:DWELL 1, 1.5, 2, 2.5, 3
```

**Step 3** Add up the total number of dwell times to determine the time of the entire list. For the previous example, the total dwell time adds up to 10 seconds. This is the time it takes to execute the list.

**Step 4** Specify the time interval and the number of points for the measurement.

```
SENSe:SWEep:TINTerval 100E-3
SENSe:SWEep:POINTs 100
```

In this example, the measurement interval is set to take 100 measurement points at 100ms intervals. The total time of the measurement therefore equals the total dwell time of the list.

**Step 5** Return the measurements from the data array.

```
Dimension an array here
FETch:CURRent:ARRay ARRAY1
```

When you read back the measurement from the array, you must determine at what point during the list that the measurement occurred. One way to do this is to multiply the measurement number by the measurement interval. For example, multiply measurement #5 by 100ms, and you get 500ms, which is the time that the measurement was made.

## Programming the Status Registers

You can use status register programming to determine the operating condition of the electronic load at any time. For example, you may program the electronic load to generate an interrupt (assert SRQ) when an event such as a current protection occurs. When the interrupt occurs, your program can then act on the event in the appropriate fashion.

Table 3-1 defines the status bits. Figure 3-4 shows the status register structure of the electronic load. The Standard Event, Status Byte, and Service Request Enable registers and the Output Queue perform standard GPIB functions as defined in the *IEEE 488.2 Standard Digital Interface for Programmable Instrumentation*. The Operation Status and Questionable Status registers implement functions that are specific to the electronic load.

**Table 3-1. Bit Configurations of Status Registers**

Bit	Signal	Meaning
<b>Operation Status Group</b>		
0	CAL	<u>Calibrating</u> . The electronic load is computing new calibration constants
5	WTG	<u>Waiting</u> . The electronic load is waiting for a trigger
<b>Channel Status Group</b>		
0	VF	<u>Voltage Fault</u> . Either an overvoltage or a reverse voltage has occurred. This bit reflects the active state of the FLT pin on the back of the unit. The bit remains set until the condition is removed and INP:PROT:CLE is programmed.
1	OC	<u>Overcurrent</u> . An overcurrent condition has occurred. This occurs if the current exceeds 102% of the rated current or if it exceeds the user-programmed current protection level. Removing the overcurrent condition clears the bit. If the condition persists beyond the user programmable delay time, bit 13 is also set and the input is turned off. Both bits remain set until the condition is removed and INP:PROT:CLE is programmed.
3	OP	<u>Overpower</u> . An overpower condition has occurred. This occurs if the unit exceeds the rated power of the input. Removing the overpower condition clears the bit. If the condition persists for more than 3 seconds, bit 13 is also set and the input is turned off. Both bits remain set until the condition is removed and INP:PROT:CLE is programmed.
4	OT	<u>Overtemperature</u> . An overtemperature condition has occurred. Both this bit and bit 13 are set and the input is turned off. Both bits remain set until the unit is cooled down and INP:PROT:CLE is programmed.
8	EPU	<u>Extended Power Unavailable</u> . When EPU status is true, an overpower condition that persists for more than 3 seconds will cause the input to be shut off and bit 13 to be set. When EPU status is false, an overpower condition will be reported in bit 3, but this will not cause the input to be turned off. The state of the EPU bit is dependent on the internal temperature of the load.
9	RRV	<u>Remote Reverse Voltage</u> . A reverse voltage condition has occurred on the sense terminals. Both this bit and bit 0 are set. Removing the reverse voltage clears this bit but does not clear bit 0. Bit 0 remains set until INP:PROT:CLE is programmed.
10	UNR	<u>Unregulated</u> . The input is unregulated. When the input is regulated the bit is cleared.
11	LRV	<u>Local Reverse Voltage</u> . A reverse voltage condition has occurred on the input terminals. Both this bit and bit 0 are set. Removing the reverse voltage clears this bit but does not clear bit 0. Bit 0 remains set until INP:PROT:CLE is programmed.
12	OV	<u>Overvoltage</u> . An overvoltage condition has occurred. Both this bit and bit 0 are set and the FETs are turned on as hard as possible to lower the voltage. Both bits remain set until the condition is removed and INP:PROT:CLE is programmed.
13	PS	<u>Protection Shutdown</u> . The protection shutdown circuit has tripped because of an overcurrent, overpower, or overtemperature condition. The bit remains set until INP:PROT:CLE is programmed.



**Table 3-1. Bit Configurations of Status Registers (continued)**

		<b>Questionable Status Group</b> Same as Channel Status Group
		<b>Standard Event Status Group</b>
0	OPC	<u>Operation Complete</u> . The load has completed all pending operations. *OPC must be programmed for this bit to be set when pending operations are complete.
2	QYE	<u>Query Error</u> . The output queue was read with no data present or the data was lost. Errors in the range of –499 through –400 can set this bit.
3	DDE	<u>Device-Dependent Error</u> . Memory was lost or self test failed. Errors in the range of –399 through –300 can set this bit.
4	EXE	<u>Execution Error</u> . A command parameter was outside its legal range, inconsistent with the load's operation, or prevented from executing because of an operating condition. Errors in the range of –299 through –200 can set this bit.
5	CME	<u>Command Error</u> . A syntax or semantic error has occurred or the load received a <get> within a program message. Errors in the range of –199 through –100 can set this bit.
7	PON	<u>Power-On</u> . The unit has been turned off and then on since this bit was last read.
		<b>Status Byte and Service Request Enable Registers</b>
2	CSUM	<u>Channel Summary</u> . Indicates if an enabled channel event has occurred.
3	QUES	<u>Questionable Status Summary</u> . Indicates if an enabled questionable event has occurred.
4	MAV	<u>Message Available Summary</u> . Indicates if the Output Queue contains data.
5	ESB	<u>Event Status Summary</u> . Indicates if an enabled standard event has occurred.
6	MSS	<u>Master Status Summary</u> . For an *STB? query, MSS is returned without being cleared.
	RQS	<u>Request Service</u> . During a serial poll, RQS is returned and cleared.
7	OPER	<u>Operation Status Summary</u> . Indicates if an operation event has occurred.

### 3 - Programming Examples

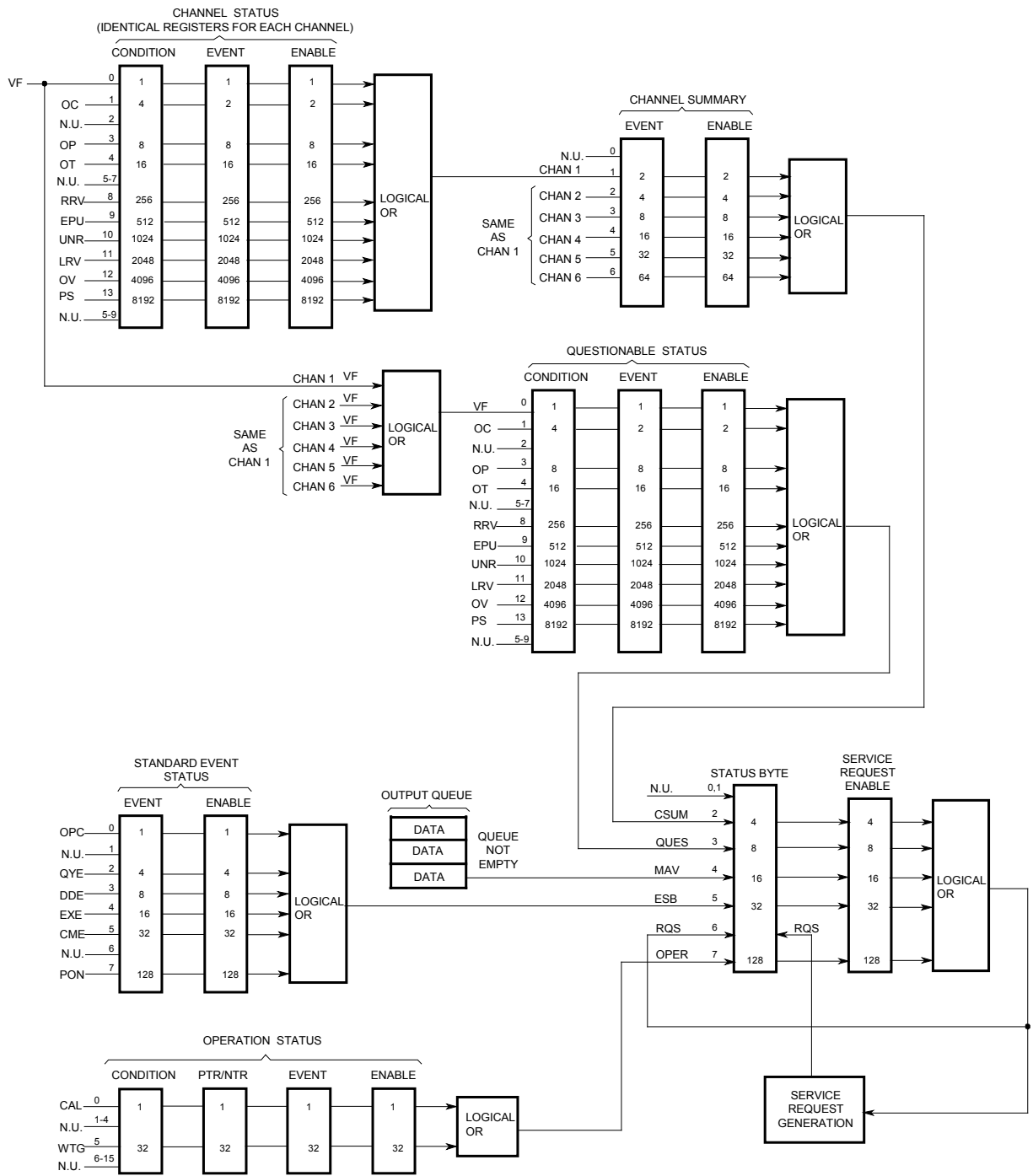

Figure 3-4. Electronic Load Status Model

## Power-On Conditions

Refer to the \*RST command description in chapter 4 for the power-on conditions of the status registers.

## Channel Status Group

The Channel Status registers record signals that indicate abnormal operation of a specific channel of the electronic load. As shown below, the group consists of a Condition, Event, and Enable register. The outputs of the Channel Status registers are logically-ORed into the Channel Summary Registers.

Register	Command	Description
Condition	STAT:CHAN:COND?	A read-only register that holds real-time status of the channel being monitored.
Event	STAT:CHAN:EVEN?	A read-only register that latches any condition. It is cleared when read.
Enable	STAT:CHAN:ENAB <n>	A read/write register that functions as a mask for enabling specific bits in the Event register.

## Channel Summary Group

The Channel Summary registers summarize the abnormal operation of all channels of the electronic load. As shown below, the group consists of an Event and Enable register. The outputs of the Channel Summary registers are logically-ORed into the Channel SUMmary bit (2) of the Status Byte register.

Register	Command	Description
Event	STAT:CSUM:EVEN?	A read-only register that latches any condition from all channels. It is cleared when read.
Enable	STAT:CSUM:ENAB <n>	A read/write register that functions as a mask for enabling specific bits in the Enable register.

## Questionable Status Group

The Questionable Status registers record signals that indicate abnormal operation of the electronic load from all of the channels. The group consists of the same type of registers as the Channel Status group. The outputs of the Questionable Status group are logically-ORed into the QUEStionable summary bit (3) of the Status Byte register.

Register	Command	Description
Condition	STAT:QUES:COND?	A read-only register that holds real-time logically ORed status of all channels of the mainframe.
Event	STAT:QUES:EVEN?	A read-only register that latches any condition. It is cleared when read.
Enable	STAT:QUES:ENAB <n>	A read/write register that functions as a mask for enabling specific bits in the Enable register.

## Standard Event Status Group

This group consists of an Event register and an Enable register that are programmed by Common commands. The Standard Event event register latches events relating to instrument communication status (see figure 3-4). It is a read-only register that is cleared when read. The Standard Event enable register functions similarly to the enable registers of the Operation and Questionable status groups.

### 3 - Programming Examples

Command	Action
*ESE	programs specific bits in the Standard Event enable register.
*PSC ON	clears the Standard Event enable register at power-on.
*ESR?	reads and clears the Standard Event event register.

#### The PON (Power On) Bit

The PON bit in the Standard Event event register is set whenever the electronic load is turned on. The most common use for PON is to generate an SRQ at power-on following an unexpected loss of power. To do this, bit 7 of the Standard Event enable register must be set so that a power-on event registers in the ESB (Standard Event Summary Bit), bit 5 of the Service Request Enable register must be set to permit an SRQ to be generated, and \*PSC OFF must be sent. The commands to accomplish these conditions are:

\*PSC OFF    \*ESE 128    \*SRE 32

#### Operation Status Group

The Operation Status registers record signals that occur during normal operation. As shown below, the group consists of a Condition, PTR/NTR, Event, and Enable register. The outputs of the Operation Status register group are logically-ORed into the OPER(ation) summary bit (7) of the Status Byte register.

Register	Command	Description
Condition	STAT:OPER:COND?	A read-only register that holds real-time status of the circuits being monitored.
PTR Filter	STAT:OPER:PTR <n>	A read/write positive transition filter that functions as described in chapter 4 under STAT:OPER:NTR   PTR.
NTR Filter	STAT:OPER:NTR <n>	A read/write negative transition filter that functions as described in chapter 4 under STAT:OPER:NTR   PTR.
Event	STAT:OPER:EVEN?	A read-only register that latches any condition that is passed through the PTR or NTR filters. It is cleared when read.
Enable	STAT:OPER:ENAB <n>	A read/write register that functions as a mask for enabling specific bits from the Event register.

#### Status Byte Register

This register summarizes the information from all other status groups as defined in the *IEEE 488.2 Standard Digital Interface for Programmable Instrumentation*. The bit configuration is shown in Table 3-1.

Command	Action
*STB?	reads the data in the register but does not clear it (returns MSS in bit 6)
serial poll	clears RQS inside the register and returns it in bit position 6 of the response.

#### The MSS Bit

This is a real-time (unlatched) summary of all Status Byte register bits that are enabled by the Service Request Enable register. MSS is set whenever the electronic load has one or more reasons for requesting service. \*STB? reads the MSS in bit position 6 of the response but does not clear any of the bits in the Status Byte register.

#### The RQS Bit

The RQS bit is a latched version of the MSS bit. Whenever the electronic load requests service, it sets the SRQ interrupt line true and latches RQS into bit 6 of the Status Byte register. When the controller does a serial poll, RQS is cleared inside the register and returned in bit position 6 of the response. The remaining bits of the Status Byte register are not disturbed.

## The MAV Bit and Output Queue

The Output Queue is a first-in, first-out (FIFO) data register that stores electronic load-to-controller messages until the controller reads them. Whenever the queue holds one or more bytes, it sets the MAV bit (4) of the Status Byte register.

## Determining the Cause of a Service Interrupt

You can determine the reason for an SRQ by the following actions:

- Step 1 Determine which summary bits are active. Use:  
\*STB? or serial poll
- Step 2 Read the corresponding Event register for each summary bit to determine which events caused the summary bit to be set. Use:  
`STATUS:QUESTIONABLE:EVENT?`  
`STATUS:OPERATION:EVENT?`  
`ESR?`  
 When an Event register is read, it is cleared. This also clears the corresponding summary bit.
- Step 3 Remove the specific condition that caused the event. If this is not possible, the event may be disabled by programming the corresponding bit of the status group Enable register or NTR|PTR filter if there is one. A faster way to prevent the interrupt is to disable the service request by programming the appropriate bit of the Service Request Enable register

## Servicing Standard Event Status and Questionable Status Events

This example assumes you want a service request generated whenever the electronic load experiences a command execution error, or whenever the electronic load's overcurrent, overpower, or overtemperature circuits have tripped. From figure 3-4, note the required path for a condition at bit 4 (EXE) of the Standard Event Status register to set bit 6 (RQS) of the Status Byte register. Also note the required path for Questionable Status conditions at bits 1, 3, and 4 to generate a service request (RQS) at the Status Byte register. The required register programming is as follows:

- Step 1 Program the Standard Event Status register to enable an event at bit 4. This allows the event to be summed into the ESB bit of the Status Byte Register. Use:  
\*ESE 4
- Step 2 Program the Questionable Status register to allow an event at bits 1, 3, or 4 to be summed into the Questionable summary bit. Use:  
`STATUS:QUESTIONABLE:ENABLE 26 (2 + 8 + 16 = 26)`
- Step 3 Program the Service Request Enable register to allow both the Standard Event Status and the Questionable summary bits from the Status Byte register to generate RQS. Use:  
\*SRE 40 (8 + 32 = 40)
- Step 4 When you service the request, read the event registers to determine which Operation Status and Questionable Status Event register bits are set, and clear the registers for the next event. Use:  
`STATUS:OPERATION:EVENT;QUESTIONABLE:EVENT?`

---

## Programming Examples

---

**NOTE:** Because of the wide variety of input ratings between load modules, not all of the values used in the following programming examples will work with every module.

---

### CC Mode Example

This example selects channel 1, sets the current level to 1.25 A and reads back the actual current value.

```
10 OUTPUT 705; "CHAN 1"  
20 OUTPUT 705;"INPUT OFF"  
30 OUTPUT 705;"FUNC CURR"  
40 OUTPUT 705;"CURR:RANG MIN"  
50 OUTPUT 705;"CURR 1.25"  
60 OUTPUT 705;"INPUT ON"  
70 OUTPUT 705;"MEAS:CURR?"  
80 ENTER 705;A  
90 DISP A  
100 END
```

Line 10: Selects the channel 1 module.  
Line 20: Turns off the input.  
Line 30: Selects the CC mode.  
Line 40: Selects the low current range.  
Line 50: Sets the current level to 1.25 amps.  
Line 60: Turns on the input.  
Line 70: Measures the actual input current and stores it in a buffer inside the electronic load.  
Line 80: Reads the input current value into variable A in the computer.  
Line 90: Displays the measured current value on the computer's display.

### CV Mode Example

This example selects channel 2, presets the voltage level to 10 volts, and selects the external trigger source. When the external trigger signal is received, the channel 2 CV level will be set to 10 volts.

```
10 OUTPUT 705; "CHAN 2::INPUT OFF"  
20 OUTPUT 705;"FUNC VOLT"  
30 OUTPUT 705;"VOLT 0"  
40 OUTPUT 705;"VOLT:TRIG 10"  
50 OUTPUT 705;"TRIG:SOUR EXT"  
60 OUTPUT 705;"INPUT ON"  
70 END
```

Line 10: Selects channel 2 and turns off the input.  
Line 20: Selects the CV mode.  
Line 30: Sets the initial voltage level to 0 volts.  
Line 40: Sets the triggered voltage level to 10 volts.  
Line 50: Selects the external input as the trigger source.  
Line 60: Turns on the channel 2 input.

## CR Mode Example

This example selects channel 1, sets the current protection limit to 2 amps, programs the resistance level to 100 ohms, and reads back the computed power.

```

10 OUTPUT 705;"CHAN 1;:INPUT OFF"
20 OUTPUT 705;"FUNC RES"
30 OUTPUT 705;"CURR:PROT:LEV 2;DEL 0.5"
40 OUTPUT 705;"CURR:PROT:STAT ON"
50 OUTPUT 705;"RES:RANG MAX"
60 OUTPUT 705;"RES 1000"
70 OUTPUT 705;"INPUT ON"
80 OUTPUT 705;"MEAS:POW?"
90 ENTER 705;A
100 DISP A
110 END

```

- Line 10: Selects channel 1 and turns off the input.
- Line 20: Selects the CR mode.
- Line 30: Sets the current protection limit to 2 amps with a trip delay of 5 seconds.
- Line 40: Enables the current protection feature.
- Line 50: Selects the high resistance range.
- Line 60: Sets the resistance level to 1000 ohms.
- Line 70: Turns on the input.
- Line 80: Reads the computed input power value and stores it in a buffer inside the electronic load.
- Line 90: Reads the computed input power level into variable A in the computer.
- Line 100: Displays the computed input power level on the computer's display.

## Continuous Transient Operation Example

This example selects channel 2, sets the CC levels and programs the slew, frequency, and duty cycle parameters for continuous transient operation.

```

10 OUTPUT 705;"CHAN 2;:INPUT OFF"
20 OUTPUT 705;"FUNC CURR"
30 OUTPUT 705;"CURR 1"
40 OUTPUT 705;"CURR:TLEV 2;SLEW MAX"
50 OUTPUT 705;"TRAN:MODE CONT;FREQ 5000;DCYC 40"
60 OUTPUT 705;"TRAN ON;:INPUT ON"
70 END

```

- Line 10: Selects channel 2 and turns the input off
- Line 20: Selects the CC mode.
- Line 30: Sets the main current level to 1 ampere.
- Line 40: Sets the transient current level to 2 amps and the slew rate to maximum.
- Line 50: Selects continuous transient operation, sets the transient generator frequency to 5 kHz, and sets the duty cycle to 40%.
- Line 60: Turns on the transient generator and the input.

### 3 - Programming Examples

#### Pulsed Transient Operation Example

This example selects channel 1, sets the CR levels, selects the bus as the trigger source, sets the fastest slew rate, programs a pulse width of 1 millisecond, and turns on transient operation. When the \*TRG command is received, a 1 millisecond pulse is generated at the channel 1 input.

```
10 OUTPUT 705;"CHAN 1;:INPUT OFF"  
20 OUTPUT 705;"FUNC RES"  
30 OUTPUT 705;"RES:RANG MAX; LEV 1000"  
40 OUTPUT 705;"RES:TLEV 2000"  
50 OUTPUT 705;"TRIG:SOUR BUS"  
60 OUTPUT 705;"RES:SLEW MAX"  
70 OUTPUT 705;"TRAN:MODE PULS;TWID .001"  
80 OUTPUT 705;"TRAN ON;:INPUT ON"  
  
200 OUTPUT 705;"*TRG"  
210 END
```

- Line 10: Selects channel 1 and turns the input off.
- Line 20: Selects the CR mode.
- Line 30: Selects the high resistance range and sets the main resistance level to 100 ohms.
- Line 40: Sets the transient resistance level to 50 ohms.
- Line 50: Selects the HP-IB as the trigger source.
- Line 60: Sets the CR slew rate to the maximum value.
- Line 70: Selects pulsed transient operation and sets the pulse width to 1 millisecond.
- Line 80: Turns on the transient generator and the input.

Other commands are executed

Line 200: The \*TRG command generates a 1 millisecond pulse at the channel 1 input.

#### Synchronous Toggled Transient Operation Example

This example programs channels 1 and 2 to generate synchronous transient waveforms. The channels can then be paralleled for increased current input. Each channel is set up to operate in the CC mode with toggled transient operation turned on. The electronic load's internal trigger oscillator is set up to produce trigger pulses at a frequency of 2 kHz in order to generate synchronous waveforms at the channel 1 and channel 2 inputs.

```
10 OUTPUT 705;"CHAN 1;:INPUT OFF"  
20 OUTPUT 705;"FUNC CURR"  
30 OUTPUT 705;"CURR 25"  
40 OUTPUT 705;"CURR:TLEV 50; SLEW MAX"  
50 OUTPUT 705;"TRAN:MODE TOGG"  
60 OUTPUT 705;"CHAN 2;:INPUT OFF"  
70 OUTPUT 705;"FUNC CURR"  
80 OUTPUT 705;"CURR 25"  
90 OUTPUT 705;"CURR:TLEV 50; SLEW MAX"  
100 OUTPUT 705;"TRAN:MODE TOGG"  
110 OUTPUT 705;"CHAN 1;:TRAN ON;:INPUT ON;:CHAN 2;:TRAN ON;:INPUT ON"  
120 OUTPUT 705;"TRIG:TIM .0005"  
130 OUTPUT 705;"TRIG:SOUR TIM"  
140 END
```



Line 10: Selects channel 1 and turns the input off.  
 Line 20: Selects the CC mode.  
 Line 30: Sets the main current level to 25 A.  
 Line 40: Sets the transient current level to 50 A and the slew rate to maximum.  
 Line 50: Selects toggled transient operation.  
 Line 60: Selects channel 2 and turns the input off.  
 Line 70: Selects the CC mode.  
 Line 80: Sets the main current level to 25 A.  
 Line 90: Sets the transient current level to 50 A and the slew to maximum.  
 Line 100: Selects toggled transient operation.  
 Line 110: Enables transient operation and turns on the input on channels 1 and 2.  
 Line 120: Sets the internal trigger oscillator frequency to 2 kHz (period of pulses = 0.0005).  
 Line 130: Selects the electronic load's internal oscillator as the trigger source. The oscillator starts running as soon as this line is executed.

### Battery Testing Example

The principal measurement of a battery's performance is its rated capacity. The capacity of a fully charged battery, at a fixed temperature, is defined as the product of the rated discharge current in amperes and the discharge time in hours, to a specified minimum termination voltage in volts (see figure 3-5). A battery is considered completely discharged when it reaches the specified minimum voltage called the "end of discharge voltage" (EODV).

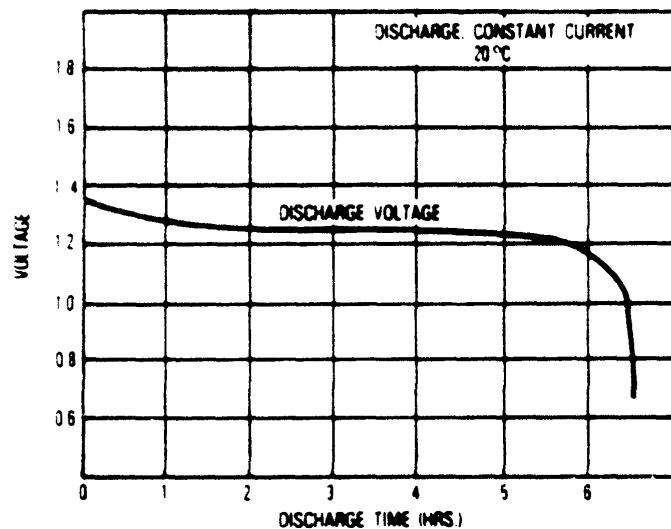

Figure 3-5. Typical Discharge Curve

In this example, the electronic load discharges three nickel-cadmium batteries to determine their discharge rates at a fixed temperature (see Figure 3-6). The batteries are connected in series so that when the EODV is reached, it is still above the minimum operating voltage of the electronic load. The EODV for nickel-cadmium batteries is typically 1.0 volts.

### 3 - Programming Examples

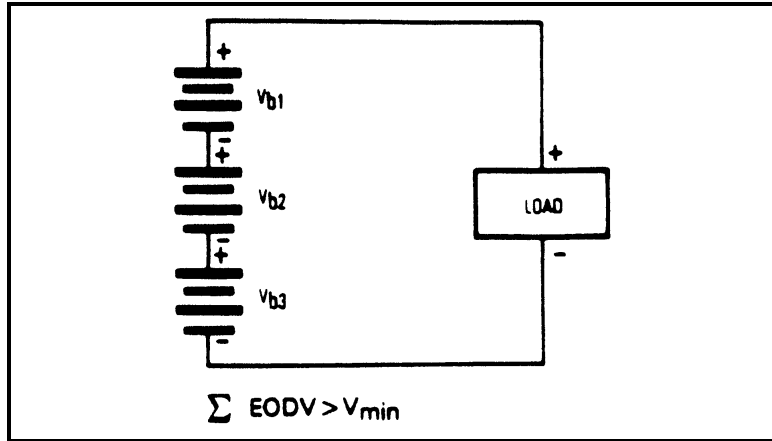

Figure 3-6. Batteries in Series

#### Battery Test Example Program

```
10      ! Battery Test Example Program
20      !
30      Eodv=1.0                ! End of discharge voltage for single cell
40      Number_of_cells=3      ! Number of cells to be discharged in series
50      Discharge_at=.05       ! Constant current discharge rate in amperes
60      !
70      OUTPUT 705;"CHAN 1;:INPUT OFF"      ! Selects Chan 1; Disables input
80      OUTPUT 705;"FUNCTION CURRENT"       ! Sets CC mode
90      OUTPUT 705;"CURRENT:LEVEL";Discharge_at ! Sets the CC level
100     OUTPUT 705;"INPUT ON"              ! Enables the input
110     !
120     Start_time=TIMEDATE                ! Records test start time
130     !
140     Start_test:                        ! Starts test routine that
150     OUTPUT 705;"MEASURE:VOLTAGE?"      ! continuously measures and reads
160     ENTER 705;Sum_of_volts             ! back the voltage and current
170     OUTPUT 705;"MEASURE:CURRENT?"     ! until batteries are completely
180     ENTER 705;Actual_current          ! discharged
190     !
200     PRINT "Total cell voltage: ";Sum_of_volts
210     PRINT "Actual current: ";Actual_current
220     PRINT "Elapsed time in seconds: ";TIMEDATE-Start_time
230     !
240     IF Sum_of_volts>(Number_of_cells*Eodv) THEN GOTO Start_test
250     !     Checks if the total voltage is less than the
260     !     sum of the minimum cell voltages of all cells
270     !
280     OUTPUT 705;"INPUT OFF"            ! Disables the input
290     !
300     END
```

## Power Supply Testing Example

A typical use for electronic loads when testing power supplies involves power supply burn-in. One of the problems associated with burn-in is what to do if the power supply fails before the test is over. One solution involves continuously monitoring the supply and removing the load if the supply fails during the test (see figure 3-7).

In this example, the electronic load is used to burn-in a power supply at its rated output current. Because the electronic load is operating in CC mode, if the power supply's output current drops below the rated output current during the test, the UNR (unregulated) condition will be set on the electronic load. This can be used to indicate that a failure has occurred on the power supply. If the unregulated condition persists for a specified time, the inputs of the electronic load are turned off.

The purpose of this example is not to illustrate power supply testing, but to explain how to program and use the status registers on the electronic load. The part of the program that runs the test simply monitors the supply at the rated output current for one hour and stops the test. You can replace this portion of the program with your own routine to test the power supply. Although SRQ (service request) is enabled to interrupt only on the UNR bit in this example, you can modify the program to interrupt on other conditions.

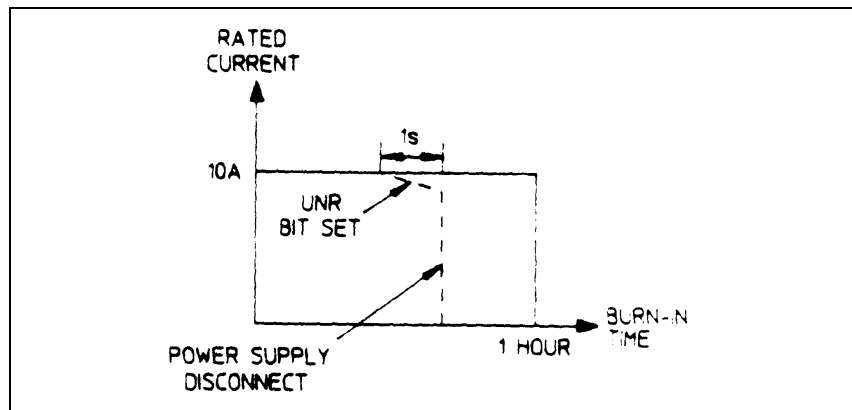

Figure 3-7. Typical Burn-In Test

### Power Supply Test Example Program

```

10   ! Power Supply Test Example Program
20   !
30   Current=10                               ! Load current in amperes
40   Burn_in_time=36000                       ! One hour burn-in time
50   !
60   ON INTR 7 GOSUB Srq_service             ! Set up interrupt linkage
70   ENABLE INTR 7;2                          ! Enable interrupts for SRQs
80   !
90   OUTPUT 705;"CHAN 1;:INPUT OFF"          ! Selects Chan 1; Disables input
100  OUTPUT 705;"*SRE 4"                     ! Enable SRQ (SRQ enable for CSUM)
110  OUTPUT 705;"STAT:CSUM:ENAB 2"          ! Enable Chan 1 (channel summary)
120  OUTPUT 705;"STAT:CHAN:ENAB 1024"       ! Enable UNR bit (channel status)
130  OUTPUT 705;"FUNCTION CURRENT"          ! Sets CC mode
140  OUTPUT 705;"CURRENT:LEVEL";Current     ! Sets the CC level
150  OUTPUT 705;"INPUT ON"                  ! Enables the input
160  !
170  PRINT "Burn-in test started at ";TIME$(TIMEDATE)
180  !
190  FOR I=1 TO Burn_in_time                  ! Loop on wait You can write your
200      WAIT .1                               ! own power supply test routine and
210      NEXT I                                ! insert it in this section
220  !

```

### 3 - Programming Examples

```
230     OUTPUT 705;"INPUT OFF"                ! Disables the input at end of test
240     PRINT "Burn-in test complete at ";TIME$(TIMEDATE)
250     STOP
260     !
270     Srq_service                          ! Service request subroutine
280     Load_status=SPOLL(705)                ! Conduct serial poll
290     IF BIT(Load_status, 6) THEN           ! Check if SRQ bit is set
300         GOSUB Check_unr
310     ELSE
320         PRINT "A condition other than UNR generated SRQ at ";TIME$(TIMEDATE)
330     END IF                                ! You can also check the other bits
340     ENABLE INTR 7                          ! Re-enable interrupts before return
350     RETURN
360     !
370     Check_unr                            ! Check if UNR bit still set
380     WAIT 1                                ! Wait 1 s before reading UNR bit
390     OUTPUT 705;"STAT:CHAN:COND?"         ! Read channel condition register
400     ENTER 705;Value
410     IF Bit(Value, 10)=0 THEN              ! Return value for UNR bit only
420         OUTPUT 705;"*CLS"                ! If 0, clear channel event register
430         PRINT "UNR was momentarily asserted at ";TIME$(TIMEDATE)
440     ELSE
450         OUTPUT 705;"INPUT OFF"           ! Disables the inputs
460         PRINT "UNR is asserted at ";TIME$(TIMEDATE);" Input is turned off"
470         STOP
480     END IF
490     RETURN
500     END
```

### C++ Programming Example

This program demonstrates the use of lists and triggered measurements in a Keysight N3300A Electronic Load. The load is programmed to step through three values of current at 1 second intervals. At each current step, the load measures its own current by sampling it 50 times at 10 microsecond intervals. The program reads back all of the data, averages the 50 samples for each of the three current steps, and outputs the results. After each current step, the measurement is delayed by 100us to allow the current to settle.

```
#include <stdio.h>
#include <stdlib.h>
#include "sicl.h"

#define MEAS_BUF_SIZE 4096 /* Size of measurement buffer in load. */

/* SICL error handler */
void ErrorHandler(INST id, int error)
{
    printf("SICL error %d\n", error);
    exit(1);
}

/* Each triggered measurement consists of nPoints samples. If multiple
 * triggered measurements are taken, all of the samples (nPoints times the
 * number of measurements) are placed in the load's measurement buffer.
 * This function averages the samples in the buffer that are associated
 * with one triggered measurement. When nIndex is 0, the first set of
 * nPoints samples are averaged; when nIndex is 1, the 2nd set of nPoints
 * samples are averaged; etc.
 */
```

```

double Average(double *pData, int nPoints, int nIndex)
{
    int nStart, nEnd, i;
    double dSum = 0.0;

    nStart = nIndex * nPoints;
    nEnd = nStart + nPoints;
    for (i = nStart; i < nEnd; ++i)
        dSum += pData[i];
    return dSum / nPoints;
}

void main(int argc, char **argv)
{
    INST    Load;
    int     i, nListSteps, nTotalPoints;
    double  aMeasData[MEAS_BUF_SIZE];

    /* This array contains the load current values, in Amps. */
    double  aListData[] = {0.5, 1.0, 1.5};

    /* The current steps occur at 1 sec intervals. */
    double  dListPeriod = 1.0;

    /* 50 measurement samples are taken at each current step. */
    int     nMeasPoints = 50;

    /* The measurement samples are taken at 10us intervals. */
    double  dMeasPeriod = 10e-6;

    /* The measurements are delayed by 100us after each current step. */
    double  dMeasDelay = 100e-6;

    /* The total number of measurement samples may not exceed the size of
     * the load's measurement buffer.
     */
    nListSteps = sizeof(aListData) / sizeof(aListData[0]);
    nTotalPoints = nMeasPoints * nListSteps;
    if (nTotalPoints > MEAS_BUF_SIZE) {
        printf("Total number of measurement points exceeds buffer size.\n");
        exit(1);
    }

    /* Set up the SICL error handler. */
    ionerror(ErrorHandler);

    /* Assume the load is set to the address shown here. */
    Load = iopen("hpib7,5");
    itimeout(Load, 10000);

    /* Put the load current into List mode. */
    iprintf(Load, "curr:mode list\n");

    /* Send the list of currents to the load. */
    iprintf(Load, "list:curr %.4,*lf\n", nListSteps, aListData);

    /* Since current is in List mode, all parameters associated with current
     * must also have lists programmed. All lists must be of the same
     * length, or they may have a single value as shown below.
     */
    iprintf(Load, "list:curr:slew max\n");
    iprintf(Load, "list:curr:range max\n");
    iprintf(Load, "list:curr:tlevel 0\n");
}

```

### 3 - Programming Examples

```
/* We are using trigger-paced lists, so set the list of dwell times to
 * minimum so no triggers are lost.
 */
iprintf(Load, "list:dwell min\n");

/* Set trigger-paced lists. */
iprintf(Load, "list:step once\n");

/* Set up the parameters for each triggered measurement. */
iprintf(Load, "sense:sweep:points %d\n", nMeasPoints);
iprintf(Load, "sense:sweep:tinterval %lf\n", dMeasPeriod);
iprintf(Load, "sense:sweep:offset %lf\n", dMeasDelay);

/* Make sure the load's trigger timer is off by setting the trigger
 * source to something else.
 */
iprintf(Load, "trig:source bus\n");

/* Set the period of the trigger timer. */
iprintf(Load, "trig:timer %lf\n", dListPeriod);

/* Set the measurement trigger count, so the measurement system can
 * be triggered multiple times (by the timer) after being initiated
 * only once.
 */
iprintf(Load, "trig:seq2:count %d\n", nListSteps);

/* Initiate the list system and the measurement system. */
iprintf(Load, "init:name list\n");
iprintf(Load, "init:name acq\n");

/* Set the trigger source to Timer. This also starts the timer, so
 * execution of the load current list and measurements will start here.
 */
iprintf(Load, "trig:source timer\n");

/* Fetch the array of data. The iscanf() call will not return until
 * all measurements are complete and the data is available.
 */
iprintf(Load, "fetch:array:curr?\n");
iflush(Load, I_BUF_READ);
iscanf(Load, "%,#lf", &nTotalPoints, &aMeasData);

/* For each list step, average the measurement samples and output the
 * results.
 */
for (i = 0; i < nListSteps; ++i)
    printf("%8.3lf\n", Average(aMeasData, nMeasPoints, i));

/* To output all the measurement samples, uncomment this loop.
 */
/* for (i = 0; i < nTotalPoints; ++i)
 *     printf("%8.3lf\n", aMeasData[i]);
 */
}
```

# Language Dictionary

---

## Introduction

This section gives the syntax and parameters for all the IEEE 488.2 SCPI subsystem and common commands used by the electronic loads. It is assumed that you are familiar with the material in chapter 2 "Introduction to Programming". Because the SCPI syntax remains the same for all programming languages, the examples given for each command are generic.

<b>Syntax Forms</b>	Syntax definitions use the long form, but only short form headers (or "keywords") appear in the examples. Use the long form to help make your program self-documenting.
<b>Parameters</b>	Most commands require a parameter and all queries will return a parameter. The range for a parameter may vary according to the model of electronic load. Parameters for all models are listed in the Specifications table in the User's Guide.
<b>Channel</b>	If a command only applies to individual channels of a mainframe, the entry Channel Selectable will appear in the command description.
<b>Related Commands</b>	Where appropriate, related commands or queries are included. These are listed because they are either directly related by function, or because reading about them will clarify or enhance your understanding of the original command or query.
<b>Order of Presentation</b>	The dictionary is organized as follows: <ul style="list-style-type: none"> <li>◆ Subsystem commands, arranged by subsystem</li> <li>◆ IEEE 488.2 common commands</li> </ul>

## Subsystem Commands

Subsystem commands are specific to functions. They can be a single command or a group of commands. The groups are comprised of commands that extend one or more levels below the root. The description of common commands follows the description of the subsystem commands.

The subsystem command groups are arranged according to function: Calibration, Channel, Input, List, Measurement, Port, Status, System, Transient, and Trigger. Commands under each function are grouped alphabetically under the subsystem. Commands followed by a question mark (?) take only the query form. When commands take both the command and query form, this is noted in the syntax descriptions.

Appendix A lists all subsystem commands in alphabetical order.

## Common Commands

Common commands begin with an \* and consist of three letters (command) or three letters and a ? (query). They are defined by the IEEE 488.2 standard to perform common interface functions. Common commands and queries are categorized under System, Status, or Trigger functions and are listed at the end of this chapter.

## Programming Parameters

The following table lists the electronic load programming parameters. Refer to Appendix A of the User's Guide for programming accuracy and resolution.

**Table 4-1. Programming Parameters**

Parameter	Code <sup>1</sup>	Model and Value					
		<b>N3302A</b>	<b>N3303A</b>	<b>N3304A</b>	<b>N3305A</b>	<b>N3306A</b>	<b>N3307A</b>
<b>CURR</b> <Nrf+>	L	0 - 3A	0 - 1A	0 - 6A	0 - 6A	0 - 12A	0 - 3A
<b>CURR:TLEV</b> <Nrf+>	H	0 - 30A	0 - 10A	0 - 60A	0 - 60A	0 - 120A	0 - 30A
<b>CURR:TRIG</b> <Nrf+>							
<b>CURR:RANG</b> <Nrf+>	L	≥0 & ≤3A	≥0 & ≤1A	≥0 & ≤6A	≥0 & ≤6A	≥0 & ≤12A	≥0 & ≤3A
	H	>3 & ≤30A	>1 & ≤10A	>6 & ≤60A	>6 & ≤60A	>12 & ≤120A	>3 & ≤30A
<b>CURR:SLEW</b> <Nrf+> (amperes/second)	B	500 - 25kA/s 50k - 2.5MA/s	167 - 8330A/s 16.7k - 833kA/s	1k - 50kA/s 100k - 5MA/s	1k - 50kA/s 100k - 5MA/s	2k - 100kA/s 200k - 10MA/s	500 - 25kA/s 50k - 2.5MA/s
<b>RES</b> <Nrf+>	1	0.067 - 4Ω	0.2 - 48Ω	0.033 - 2Ω	0.033 - 5Ω	0.017 - 1Ω	0.067 - 10Ω
<b>RES:TLEV</b> <Nrf+>	2	3.6 - 40Ω	44 - 480Ω	1.8 - 20Ω	4.5 - 50Ω	0.9 - 10Ω	9 - 100Ω
<b>RES:TRIG</b> <Nrf+>	3	36 - 400Ω	440 - 4.8kΩ	18 - 200Ω	45 - 500Ω	9 - 100Ω	90 - 1kΩ
	4	360 - 2kΩ	4.4k - 12kΩ	180 - 2kΩ	450 - 2.5kΩ	90 - 1kΩ	900 - 2.5kΩ
<b>RES:RANG</b> <Nrf+>	1	≥0 & ≤4Ω	≥0 & ≤48Ω	≥0 & ≤2Ω	≥0 & ≤5Ω	≥0 & ≤1Ω	≥0 & ≤10Ω
	2	>4 & ≤40Ω	>48 & ≤480Ω	>2 & ≤20Ω	>5 & ≤50Ω	>1 & ≤10Ω	>10 & ≤100Ω
	3	>40 & ≤400Ω	>480 & ≤4.8kΩ	>20 & ≤200Ω	>50 & ≤500Ω	>10 & ≤100Ω	>100 & ≤1kΩ
	4	>400 & ≤2kΩ	>4.8k & ≤12kΩ	>200 & ≤2kΩ	>500 & ≤2.5kΩ	>100 & ≤1kΩ	>1k & ≤2.5kΩ
<b>RES:SLEW</b> <Nrf+> (ohms/second)	1	44 - 1125Ω/s 2250 - 34kΩ/s	540 - 13.5kΩ/s 27k - 408kΩ/s	22 - 560Ω/s 1120 - 17kΩ/s	55 - 1400Ω/s 2800 - 42.5kΩ/s	11 - 280Ω/s 560 - 8.5kΩ/s	110 - 2800Ω/s 5600 - 85kΩ/s
	2	440-11.25kΩ/s 22.5k-340kΩ/s	5.4k - 135kΩ/s 270k-4.08MΩ/s	220 - 5600Ω/s 11.2k-170kΩ/s	550 - 14kΩ/s 28k - 425kΩ/s	110 - 2800Ω/s 5600 - 85kΩ/s	1.1k - 28kΩ/s 56k - 850kΩ/s
	3	4.4k-112.5kΩ/s 225k - 3.4MΩ/s	54k - 1.35MΩ/s 2.7M- 40.8MΩ/s	2.2k - 56kΩ/s 112k-1.7MΩ/s	5.5k - 140kΩ/s 280k-4.25MΩ/s	1.1k - 28kΩ/s 56k - 850kΩ/s	11k - 280kΩ/s 560k - 8.5MΩ/s
	4	44k-1.125MΩ/s 2.25M-34MΩ/s	540k- 13.5MΩ/s 27M - 408MΩ/s	22k - 560kΩ/s 1.12M- 17MΩ/s	55k - 1.4MΩ/s 2.8M-42.5MΩ/s	11k - 280kΩ/s 560k - 8.5MΩ/s	110k - 2.8MΩ/s 5.6M - 85MΩ/s
<b>VOLT</b> <Nrf+>	L	0 - 6V	0 - 24V	0 - 6V	0 - 15V	0 - 6V	0 - 15V
<b>VOLT:TLEV</b> <Nrf+>	H	0 - 60V	0 - 240V	0 - 60V	0 - 150V	0 - 60V	0 - 150V
<b>VOLT:TRIG</b> <Nrf+>							
<b>VOLT:RANG</b> <Nrf+>	L	≥0 & ≤6V	≥0 & ≤24V	≥0 & ≤6V	≥0 & ≤15V	≥0 & ≤6V	≥0 & ≤15V
	H	>6 & ≤60V	>24 & ≤240V	>6 & ≤60V	>15 & ≤150V	>6 & ≤60V	>15 & ≤150V
<b>VOLT:SLEW</b> <Nrf+> (volts/second)	B	1k - 50kV/s 100k - 500kV/s	4k - 200kV/s 400k - 2MV/s	1k - 50kV/s 100k - 500kV/s	2.5k - 125kV/s 250k - 1.25MV/s	1k - 50kV/s 100k - 500kV/s	2.5k - 125kV/s 250k - 1.25MV/s
<b>CURR:PROT</b> <Nrf+> <sup>2</sup>		0 - 30.6A	0 - 10.2A	0 - 61.2A	0 - 61.2A	0 - 122.4A	0 - 30.6A
<b>CURR:PROT:DEL</b> <Nrf+>		0 - 60s					
<b>TRAN:FREQ</b> <Nrf+>		0.25Hz - 10kHz					
<b>TRAN:DCYC</b> <Nrf+>		1.8% - 98.2%					
<b>TRAN:TWID</b> <Nrf+>		50μs - 4s					
<b>TRIG:TIM</b> <Nrf+>		8μs - 4s					
<b>TRIG:DEL</b> <Nrf+>		0 - 0.032s					

<sup>1</sup>Code: L = Low range      1 = Resistance range 1      3 = Resistance range 3  
 H = High range      2 = Resistance range 2      4 = Resistance range 4  
 B = Both ranges

<sup>2</sup>CURR:PROT - A fixed offset equivalent to 1% of the unit's full-scale rated current (H) is automatically added to the programmed value. So, for example, if you are programming the current protection of an N3306A to 100A, the actual setting will be 101.2A (programmed value + 1% of full-scale rated current).



## Calibration Commands

Calibration commands let you:

- ◆ Enable and disable the calibration mode
- ◆ Change the calibration password
- ◆ Calibrate the input functions, current monitor offset and gain, and store new calibration constants in nonvolatile memory.

### CALibrate:DATA

This command is only used in calibration mode. It enters a calibration value that you obtain by reading an external meter. You must first select a calibration level (with CALibrate:LEVel) for the value being entered. These constants are not stored in nonvolatile memory until they are saved with CALibrate:SAVE. If CALibrate:STATE OFF is programmed without a CALibrate:SAVE, the previous calibration constants are restored.

**Command Syntax** CALibrate:DATA <NRf> {,<NRf>,<NRf>}  
**Parameters** <external reading>  
**Examples** CAL:DATA 3222.3      CAL:DATA 5.000  
**Related Commands** CAL:STAT    CAL:SAV

### CALibrate:IMON:LEVel

This command can only be used in calibration mode. It is used to set the two calibration points of the analog current monitor signal.

**Command Syntax** CALibrate:IMON:LEVel <level>  
**Parameters** P1 | P2  
**Examples** CAL:LEV P2  
**Related Commands** CAL:STAT    CAL:SAV

### CALibrate:IPR:LEVel

This command can only be used in calibration mode. It is used to set the four calibration points for calibrating the gains of the analog current monitor signal and the analog current programming signal.

**Command Syntax** CALibrate:IPRog:LEVel <level>  
**Parameters** P1 | P2 | P3 | P4  
**Examples** CAL:LEV P2  
**Related Commands** CAL:STAT    CAL:SAV

### CALibrate:LEVel

This command can only be used in calibration mode. It is used to set the two calibration points of the presently selected FUNCTION and RANGE.

**Command Syntax** CALibrate:LEVel <level>  
**Parameters** P1 | P2  
**Examples** CAL:LEV P2  
**Related Commands** CAL:STAT    CAL:SAV

## CALibrate:PASSword

This command can only be used in calibration mode. It allows you to change the calibration password. The new password is not saved until you send the CALibrate:SAVE command. If the password is set to 0, password protection is removed and the ability to enter the calibration mode is unrestricted.

**Command Syntax** CALibrate:PASSword <NRf>  
**Parameters** 0 (default)  
**Examples** CAL:PASS N3301A      CAL:PASS 02.1997  
**Related Commands** CAL:STAT

## CALibrate:SAVE

This command can only be used in calibration mode. It saves any new calibration constants (after a current or voltage calibration procedure has been completed) in nonvolatile memory.

**Command Syntax** CALibrate:SAVE  
**Parameters** None  
**Examples** CAL:SAVE  
**Related Commands** CAL:STAT

## CALibrate:STATe

This command enables and disables calibration mode. The calibration mode must be enabled before the load will accept any other calibration commands. The first parameter specifies the enabled or disabled state. The second parameter is the password. It is required if the calibration mode is being enabled and the existing password is not 0. If the password is not entered or is incorrect, an error is generated and the calibration mode remains disabled. The query statement returns only the state, not the password.

Whenever the calibration state is changed from enabled to disabled, any new calibration constants are lost unless they have been stored with CALibrate:SAVE.

**Command Syntax** CALibrate:STATe <bool> [,<NRf>]  
**Parameters** 0 | 1 | OFF | ON [,<password>]  
**\*RST Value** OFF  
**Examples** CAL:STAT 1, N3301A      CAL:STAT OFF  
**Query Syntax** CALibrate:STATe?  
**Returned Parameters** <NR1>  
**Related Commands** CAL:PASS      CAL:SAVE

## Channel Commands

These commands program the channel selection capability of the electronic load. The CHANnel and INSTrument commands are equivalent.

### CHANnel INSTrument

These commands select the multiple electronic load channel to which all subsequent channel-specific commands will be directed. If the specified channel number does not exist or is outside the MIN/MAX range, an error code is generated (see appendix C). Refer to the installation section of the User's Guide for more information about channel number assignments.

<b>Command Syntax</b>	CHANnel[:LOAD] <NRf+> INSTrument[:LOAD] <NRf+>
<b>Parameters</b>	1 - 6
<b>*RST Value</b>	1
<b>Examples</b>	CHAN:LOAD 3            INST 2
<b>Query Syntax</b>	CHANnel? (NOTE: Use CHAN? MAX to return the number of channels installed in a load mainframe)
<b>Returned Parameters</b>	<NR1>

## Input Commands

These commands control the input of the electronic load. The INPut and OUTPut commands are equivalent. The CURRent, RESistance and VOLTage commands program the actual input current, resistance, and voltage.

### [SOURce:]INPut [SOURce:]OUTPut

#### Channel Specific

These commands enable or disable the electronic load inputs. The state of a disabled input is a high impedance condition.

<b>Command Syntax</b>	[SOURce:]INPut[:STATe] <bool> [SOURce:]OUTPut[:STATe] <bool>
<b>Parameters</b>	0   1   OFF   ON
<b>*RST Value</b>	ON
<b>Examples</b>	INP 1            OUTP:STAT ON
<b>Query Syntax</b>	INPut[:STATe]? OUTPut[:STATe]?
<b>Returned Parameters</b>	0   1
<b>Related Commands</b>	*RCL   *SAV

### [SOURce:]INPut:PROTection:CLEAr [SOURce:]OUTput:PROTection:CLEAr

#### Channel Specific

These commands clear the latch that disables the input when a protection condition such as overvoltage (OV) or overcurrent (OC) is detected. All conditions that generated the fault must be removed before the latch can be cleared. The input is then restored to the state it was in before the fault condition occurred.

<b>Command Syntax</b>	[SOURce:]INPut:PROTection:CLEAr [SOURce:]OUTPut:PROTection:CLEAr
<b>Parameters</b>	None
<b>Examples</b>	OUTP:PROT:CLE
<b>Related Commands</b>	OUTP:PROT:DEL   *SAV   *RCL

### [SOURce:]INPut:SHORT [SOURce:]OUTPut:SHORT

#### Channel Specific

This command programs the specified electronic load module to the maximum current that it can sink in the present operating range.

<b>Command Syntax</b>	[SOURce:]INPut:SHORT <bool> [SOURce:]OUTPut:SHORT <bool>
<b>Parameters</b>	0   1   OFF   ON
<b>*RST Value</b>	OFF
<b>Examples</b>	INP:SHOR 1            OUTP:SHOR ON
<b>Query Syntax</b>	INPut:SHORT?
<b>Returned Parameters</b>	0   1
<b>Related Commands</b>	INP            OUTP

**[SOURce:]CURRent****Channel Specific**

This command sets the current that the load will regulate when operating in constant current mode. Refer to Table 4-1 for model-specific programming ranges.

<b>Command Syntax</b>	[SOURce:]CURRent[:LEVel][:IMMediate][:AMPLitude] <NRf+>
<b>Parameters</b>	0 through MAX   MINimum   MAXimum
<b>Unit</b>	A (amperes)
<b>*RST Value</b>	MINimum
<b>Examples</b>	CURR 5            CURR:LEV .5
<b>Query Syntax</b>	[SOURce:]CURRent[:LEVel][:IMMediate][:AMPLitude]?
<b>Returned Parameters</b>	<NR3>
<b>Related Commands</b>	CURR:TLEV            CURR:MODE

**[SOURce:]CURRent:MODE****Channel Specific**

This command determines whether the current settings are controlled by values in a list or by the CURRent command setting.

<b>FIXed</b>	The current settings are determined by the CURRent command.
<b>LIST</b>	The current settings are determined by the active list.

<b>Command Syntax</b>	[SOURce:]CURRent:MODE <mode>
<b>Parameters</b>	FIXed   LIST
<b>*RST Value</b>	FIXed
<b>Examples</b>	CURR:MODE FIX
<b>Query Syntax</b>	[SOURce:]CURRent:MODE?
<b>Returned Parameters</b>	<CRD>
<b>Related Commands</b>	CURR:    CURR:TRIG

**[SOURce:]CURRent:PROTection****Channel Specific**

This command sets the soft current protection level. If the input current exceeds the soft current protection level for the time specified by CURR:PROT:DEL, the input is turned off. Refer to Table 4-1 for model-specific programming ranges. (Use CURR:PROT:DEL to prevent momentary current limit conditions caused by programmed changes from tripping the overcurrent protection.)

---

**NOTE:** A fixed offset equivalent to 1% of the unit's full-scale rated current is automatically added to the programmed value. So, for example, if you are programming the current protection of an N3306A to 100A, the actual setting will be 101.2A (programmed value + 1% of rated current).

---

<b>Command Syntax</b>	[SOURce:]CURRent:PROTection[:LEVel] <NRf+>
<b>Parameters</b>	0 through MAX   MINimum   MAXimum
<b>Unit</b>	A (amperes)
<b>*RST Value</b>	MAXimum
<b>Examples</b>	CURR:PROT 10
<b>Query Syntax</b>	[SOURce:]CURRent:PROTection?
<b>Returned Parameters</b>	<NR3>
<b>Related Commands</b>	CURR:PROT:DEL    CURR:PROT:STAT

**[SOURce:]CURRent:PROTection:DELay****Channel Specific**

This command specifies the time that the input current can exceed the protection level before the input is turned off.

<b>Command Syntax</b>	[SOURce:]CURRent:PROTection:DELay <NRf+>
<b>Parameters</b>	0 to 60 seconds
<b>Unit</b>	seconds
<b>*RST Value</b>	0
<b>Examples</b>	CURR:PROT:DEL .5
<b>Query Syntax</b>	[SOURce:]CURRent:PROTection:DELay?
<b>Returned Parameters</b>	<NR3>
<b>Related Commands</b>	CURR:PROT    CURR:PROT:STAT

**[SOURce:]CURRent:PROTection:STATe****Channel Specific**

This command enables or disables the over-current protection feature.

<b>Command Syntax</b>	[SOURce:]CURRent:PROTection:STATe <Bool>
<b>Parameters</b>	0   1   OFF   ON
<b>*RST Value</b>	OFF
<b>Examples</b>	CURR:PROT:STAT 1            CURR:PROT:STAT ON
<b>Query Syntax</b>	[SOURce:]CURRent:PROTection:STATe?
<b>Returned Parameters</b>	<NR3>
<b>Related Commands</b>	CURR:PROT

**[SOURce:]CURRent:RANGe****Channel Specific**

This command sets the current range of the electronic load module. There are two current ranges.

**High Range:** model dependent, see Table 4-1

**Low Range:** model dependent, see Table 4-1

When you program a range value, the load automatically selects the range that corresponds to the value that you program. If the value falls in a region where ranges overlap, the load selects the range with the highest resolution.

---

<b>NOTE:</b>	When this command is executed, the IMMEDIATE, TRANsient, TRIGgered, and SLEW current settings are adjusted as follows:
	<b>If the existing settings are within the new range:</b> No adjustment is made.
	<b>If the existing settings are outside the new range:</b> The levels are set to the maximum value of the new range.

---

<b>Command Syntax</b>	[SOURce:]CURRent:RANGe <NRf+>
<b>Parameters</b>	0 through MAX   MINimum   MAXimum
<b>Unit</b>	A (amperes)
<b>*RST Value</b>	MAXimum (high range)
<b>Examples</b>	SOUR:CURR:RANGE MIN
<b>Query Syntax</b>	[SOURce:]CURRent:RANGe?
<b>Returned Parameters</b>	<NR3>
<b>Related Commands</b>	CURR                    CURR:SLEW

**[SOURce:]CURRent:SLEW****Channel Specific**

This command sets the slew rate for all programmed changes in the input current level of the electronic load. This command programs both positive and negative going slew rates. Although any slew rate value may be entered, the electronic load selects a slew rate that is closest to the programmed value. MAXimum sets the slew to the fastest possible rate. MINimum sets the slew to the slowest rate. Slew rates less than the minimum value are set to MINimum. Slew rates greater than the maximum value are set to MAXimum.

<b>Command Syntax</b>	[SOURce:]CURRent:SLEW[:BOTH] <NRf+>
<b>Parameters</b>	0 to 9.9E37   MAXimum   MINimum
<b>Unit</b>	A (amps per second)
<b>*RST Value</b>	MAXimum
<b>Examples</b>	CURR:SLEW 50      CURR:SLEW MAX
<b>Query Syntax</b>	[SOURce:]CURRent:SLEW[:BOTH]?
<b>Returned Parameters</b>	<NR3>
<b>Related Commands</b>	CURR:SLEW:NEG    CURR:SLEW:POS

**[SOURce:]CURRent:SLEW:NEGative****Channel Specific**

This command sets the slew rate of the current for negative going transitions. MAXimum sets the slew to the fastest possible rate. MINimum sets the slew to the slowest rate.

<b>Command Syntax</b>	[SOURce:]CURRent:SLEW:NEGative <NRf+>
<b>Parameters</b>	0 to 9.9E37   MAXimum   MINimum
<b>Unit</b>	A (amps per second)
<b>*RST Value</b>	MAXimum
<b>Examples</b>	CURR:SLEW:NEG 50      CURR:SLEW:NEG MAX
<b>Query Syntax</b>	[SOURce:]CURRent:SLEW:NEGative?
<b>Returned Parameters</b>	<NR3>
<b>Related Commands</b>	CURR:SLEW

**[SOURce:]CURRent:SLEW:POSitive****Channel Specific**

This command sets the slew rate of the current for positive going transitions. MAXimum sets the slew to the fastest possible rate. MINimum sets the slew to the slowest rate.

<b>Command Syntax</b>	[SOURce:]CURRent:SLEW:POSitive <NRf+>
<b>Parameters</b>	0 to 9.9E37   MAXimum   MINimum
<b>Unit</b>	A (amps per second)
<b>*RST Value</b>	MAXimum
<b>Examples</b>	CURR:SLEW:POS 50      CURR:SLEW:POS MAX
<b>Query Syntax</b>	[SOURce:]CURRent:SLEW:POSitive?
<b>Returned Parameters</b>	<NR3>
<b>Related Commands</b>	CURR:SLEW

**[SOURce:]CURRENT:TLEVEL****Channel Specific**

This command specifies the transient level of the input current. The transient function switches between the immediate setting and the transient level. Refer to Table 4-1 for model-specific programming ranges.

<b>Command Syntax</b>	[SOURce:]CURRENT:TLEVEL <NRf+>
<b>Parameters</b>	0 through MAX   MINimum   MAXimum
<b>Unit</b>	A (amperes)
<b>*RST Value</b>	MAXimum
<b>Examples</b>	CURR:TLEV 5            CURR:TLEV .5
<b>Query Syntax</b>	[SOURce:]CURRENT:TLEVEL?
<b>Returned Parameters</b>	<NR3>
<b>Related Commands</b>	CURR:

**[SOURce:]CURRENT:TRIGGERed****Channel Specific**

This command sets the current level that will become active when the next trigger occurs.

<b>Command Syntax</b>	[SOURce:]CURRENT[:LEVEL]:TRIGGERed[:AMPLitude] <NRf+>
<b>Parameters</b>	refer to Specifications Table in User's Guide
<b>Unit</b>	A (amperes)
<b>*RST Value</b>	MINimum
<b>Examples</b>	CURR:TRIG 15
<b>Query Syntax</b>	[SOURce:]CURRENT:TRIG?
<b>Returned Parameters</b>	<NR3> (if the trigger level is not programmed, the immediate level is returned)
<b>Related Commands</b>	CURR:    CURR:MODE

**[SOURce:]FUNCTION****[SOURce:]MODE****Channel Specific**

These equivalent commands select the input regulation mode of the electronic load.

<b>CURRENT</b>	constant current mode
<b>RESistance</b>	constant resistance mode
<b>VOLTage</b>	constant voltage mode

<b>Command Syntax</b>	[SOURce:]FUNCTION <function>	[SOURce:]MODE <function>
<b>Parameters</b>	CURRENT   RESistance   VOLTage	
<b>*RST Value</b>	CURRENT	
<b>Examples</b>	FUNC RES            MODE VOLT	
<b>Query Syntax</b>	[SOURce:]FUNCTION?            [SOURce:]MODE?	
<b>Returned Parameters</b>	<CRD>	
<b>Related Commands</b>	FUNC MODE    FUNC TRIG    VOLT	
<b>Equivalent Commands</b>	MODE:CURR            MODE:RES            MODE:VOLT	



**[SOURce:]FUNCtion:MODE****Channel Specific**

This command determines whether the input regulation mode is controlled by values in a list or by the FUNCtion command setting.

**FIXed** The regulation mode is determined by the FUNCtion or MODE command.  
**LIST** The regulation mode is determined by the active list.

**Command Syntax** [SOURce:]FUNCtion:MODE <mode>  
**Parameters** FIXed | LIST  
**\*RST Value** FIXed  
**Examples** FUNC:MODE FIX  
**Query Syntax** [SOURce:]FUNCtion:MODE?  
**Returned Parameters** <CRD>  
**Related Commands** FUNC MODE

**[SOURce:]RESistance****Channel Specific**

This command sets the resistance of the load when operating in constant resistance mode. Refer to Table 4-1 for model-specific programming ranges.

**Command Syntax** [SOURce:]RESistance[:LEVel][:IMMediate][:AMPLitude] <NRf+>  
**Parameters** 0 through MAX | MINimum | MAXimum  
**Unit**  $\Omega$  (ohms)  
**\*RST Value** MAXimum  
**Examples** RES 5 RES:LEV .5  
**Query Syntax** [SOURce:]RESistance[:LEVel][:IMMediate][:AMPLitude]?  
**Returned Parameters** <NR3>  
**Related Commands** RES:TLEV RES:MODE

**[SOURce:]RESistance:MODE****Channel Specific**

This command determines whether the resistance setting is controlled by values in a list or by the RESistance command setting.

**FIXed** The resistance setting is determined by the RESistance command.  
**LIST** The resistance setting is determined by the active list.

**Command Syntax** [SOURce:]RESistance:MODE <mode>  
**Parameters** FIXed | LIST  
**\*RST Value** FIXed  
**Examples** RES:MODE FIX  
**Query Syntax** [SOURce:]RESistance:MODE?  
**Returned Parameters** <CRD>  
**Related Commands** RES: RES:TRIG

**[SOURce:]RESistance:RANGe****Channel Specific**

This command sets the resistance range of the electronic load module. There are four resistance ranges, the values of which are model dependent. Refer to Table 4-1 for the resistance ranges of each electronic load model.

When you program a range value, the load automatically selects the range that corresponds to the value that you program. If the value falls in a region where ranges overlap, the load selects the range with the highest resolution.

---

**NOTE:** When this command is executed, the IMMEDIATE, TRANSient, TRIGgered, and SLEW resistance settings are adjusted as follows:  
**If the existing settings are within the new range:** No adjustment is made.  
**If the existing settings are outside the new range:** The levels are set to either the maximum or minimum value of the new range, depending on which they are closest to.

---

<b>Command Syntax</b>	[SOURce:]RESistance:RANGe <NRf+>
<b>Parameters</b>	0 through MAX   MINimum   MAXimum
<b>Unit</b>	$\Omega$ (ohms)
<b>*RST Value</b>	MAXimum (high range)
<b>Examples</b>	RES:RANG 15                      SOUR:RES:RANGE MIN
<b>Query Syntax</b>	[SOURce:]RESistance:RANGe?
<b>Returned Parameters</b>	<NR3>
<b>Related Commands</b>	RES                              RES:SLEW

**[SOURce:]RESistance:SLEW****Channel Specific**

This command sets the slew rate for all programmed changes in the resistance level of the electronic load. This command programs both positive and negative going slew rates. Although any slew rate value may be entered, the electronic load selects a slew rate that is closest to the programmed value. MAXimum sets the slew to the fastest possible rate. MINimum sets the slew to the slowest rate. Slew rates less than the minimum value are set to MINimum. Slew rates greater than the maximum value are set to MAXimum.

<b>Command Syntax</b>	[SOURce:]RESistance:SLEW[:BOTH] <NRf+>
<b>Parameters</b>	0 to 9.9E37   MAXimum   MINimum
<b>Unit</b>	$\Omega$ (ohms/second)
<b>*RST Value</b>	MAXimum
<b>Examples</b>	RES:SLEW 50                      RES:SLEW MAX
<b>Query Syntax</b>	[SOURce:]RESistance:SLEW[:BOTH]?
<b>Returned Parameters</b>	<NR3>
<b>Related Commands</b>	RES:SLEW:POS      RES:SLEW:NEG

**[SOURce:]RESistance:SLEW:NEGative****Channel Specific**

This command sets the slew rate of the resistance for negative going transitions. MAXimum sets the slew to the fastest possible rate. MINimum sets the slew to the slowest rate.

<b>Command Syntax</b>	[SOURce:]RESistance:SLEW:NEGative <NRf+>
<b>Parameters</b>	0 to 9.9E37   MAXimum   MINimum
<b>Unit</b>	$\Omega$ (ohms/second)
<b>*RST Value</b>	MAXimum
<b>Examples</b>	RES:SLEW:NEG 50      RES:SLEW:NEG MAX
<b>Query Syntax</b>	[SOURce:]RESistance:SLEW:NEGative?
<b>Returned Parameters</b>	<NR3>
<b>Related Commands</b>	RES:SLEW

## [SOURce:]RESistance:SLEW:POSitive

### Channel Specific

This command sets the slew rate of the resistance for positive going transitions. MAXimum sets the slew to the fastest possible rate. MINimum sets the slew to the slowest rate.

<b>Command Syntax</b>	[SOURce:]RESistance:SLEW:POSitive <NRf+>
<b>Parameters</b>	0 to 9.9E37   MAXimum   MINimum
<b>Unit</b>	$\Omega$ (ohms/second)
<b>*RST Value</b>	MAXimum
<b>Examples</b>	RES:SLEW:POS 50      RES:SLEW:POS MAX
<b>Query Syntax</b>	[SOURce:]RESistance:SLEW:POSitive?
<b>Returned Parameters</b>	<NR3>
<b>Related Commands</b>	RES:SLEW

## [SOURce:]RESistance:TLEVel

### Channel Specific

This command specifies the transient level of the resistance. The transient function switches between the immediate setting and the transient level. Refer to Table 4-1 for model-specific programming ranges.

<b>Command Syntax</b>	[SOURce:]RESistance:TLEVel <NRf+>
<b>Parameters</b>	0 through MAX   MINimum   MAXimum
<b>Unit</b>	$\Omega$ (ohms)
<b>*RST Value</b>	MAXimum
<b>Examples</b>	RES:TLEV 5      RES:TLEV .5
<b>Query Syntax</b>	[SOURce:]RESistance:TLEVel?
<b>Returned Parameters</b>	<NR3>
<b>Related Commands</b>	RES:

## [SOURce:]RESistance:TRIGgered

### Channel Specific

This command sets the resistance level that will become active when the next trigger occurs.

<b>Command Syntax</b>	[SOURce:]RESistance[:LEVel]:TRIGgered[:AMPLitude] <NRf+>
<b>Parameters</b>	refer to Specifications Table in User's Guide
<b>Unit</b>	$\Omega$ (ohms)
<b>*RST Value</b>	MAXimum
<b>Examples</b>	RES:TRIG 120      RES:LEV:TRIG 150
<b>Query Syntax</b>	[SOURce:]RESistance[:LEVel]:TRIGgered[:AMPLitude]?
<b>Returned Parameters</b>	<NR3> (if the trigger level is not programmed, the immediate level is returned)
<b>Related Commands</b>	RES    RES:MODE

**[SOURce:]VOLTage****Channel Specific**

This command sets the voltage that the load will regulate when operating in constant voltage mode. Refer to Table 4-1 for model-specific programming ranges.

<b>Command Syntax</b>	[SOURce:]VOLTage[:LEVel][:IMMediate][:AMPLitude] <NRf+>
<b>Parameters</b>	0 through MAX   MINimum   MAXimum
<b>Unit</b>	V (volts)
<b>*RST Value</b>	MAXimum
<b>Examples</b>	VOLT 5            VOLT:LEV .5
<b>Query Syntax</b>	[SOURce:]VOLTage[:LEVel][:IMMediate][:AMPLitude]?
<b>Returned Parameters</b>	<NR3>
<b>Related Commands</b>	VOLT:TLEV            VOLT:MODE

**[SOURce:]VOLTage:MODE****Channel Specific**

This command determines whether the voltage setting is controlled by values in a list or by the VOLTage command setting.

<b>FIXed</b>	The voltage setting is determined by the VOLTage command.
<b>LIST</b>	The voltage setting is determined by the active list.

<b>Command Syntax</b>	[SOURce:]VOLTage:MODE <mode>
<b>Parameters</b>	FIXed   LIST
<b>*RST Value</b>	FIXed
<b>Examples</b>	VOLT:MODE FIX
<b>Query Syntax</b>	[SOURce:]VOLTage:MODE?
<b>Returned Parameters</b>	<CRD>
<b>Related Commands</b>	VOLT:    VOLT:TRIG

**[SOURce:]VOLTage:RANGE****Channel Specific**

This command sets the voltage range of the electronic load module. There are two voltage ranges.

**High Range:** model dependent, see Table 4-1

**Low Range:** model dependent, see Table 4-1

When you program a range value, the load automatically selects the range that corresponds to the value that you program. If the value falls in a region where ranges overlap, the load selects the range with the highest resolution.

---

<b>NOTE:</b>	When this command is executed, the IMMEDIATE, TRANSient, TRIGgered, and SLEW voltage settings are adjusted as follows:
	<b>If the existing settings are within the new range:</b> No adjustment is made.
	<b>If the existing settings are outside the new range:</b> The levels are set to the maximum value of the new range.

---

<b>Command Syntax</b>	[SOURce:]VOLTage:RANGe <NRf+>
<b>Parameters</b>	0 through MAX   MINimum   MAXimum
<b>Unit</b>	V (volts)
<b>*RST Value</b>	MAXimum (high range)
<b>Examples</b>	VOLT:RANG 15                      SOUR:VOLT:RANGE MIN
<b>Query Syntax</b>	[SOURce:]VOLTage:RANGe?
<b>Returned Parameters</b>	<NR3>
<b>Related Commands</b>	VOLT                      VOLT:SLEW

## [SOURce:]VOLTage:SLEW

### Channel Specific

This command sets the slew rate for all programmed changes in the input voltage level of the electronic load. This command programs both positive and negative going slew rates. Although any slew rate value may be entered, the electronic load selects a slew rate that is closest to the programmed value. MAXimum sets the slew to the fastest possible rate. MINimum sets the slew to the slowest rate. Slew rates less than the minimum value are set to MINimum. Slew rates greater than the maximum value are set to MAXimum.

<b>Command Syntax</b>	[SOURce:]VOLTage:SLEW[:BOTH] <NRf+>
<b>Parameters</b>	0 to 9.9E37   MAXimum   MINimum
<b>Unit</b>	V (volts per second)
<b>*RST Value</b>	MAXimum
<b>Examples</b>	VOLT:SLEW 50                      VOLT:SLEW MAX
<b>Query Syntax</b>	[SOURce:]VOLTage:SLEW[:BOTH]?
<b>Returned Parameters</b>	<NR3>
<b>Related Commands</b>	VOLT:SLEW:POS      VOLT:SLEW:NEG

## [SOURce:]VOLTage:SLEW:NEGative

### Channel Specific

This command sets the slew rate of the voltage for negative going transitions. MAXimum sets the slew to the fastest possible rate. MINimum sets the slew to the slowest rate.

<b>Command Syntax</b>	[SOURce:]VOLTage:SLEW:NEGative <NRf+>
<b>Parameters</b>	0 to 9.9E37   MAXimum   MINimum
<b>Unit</b>	V (volts per second)
<b>*RST Value</b>	MAXimum
<b>Examples</b>	VOLT:SLEW:NEG 50                      VOLT:SLEW:NEG MAX
<b>Query Syntax</b>	[SOURce:]VOLTage:SLEW:NEGative?
<b>Returned Parameters</b>	<NR3>
<b>Related Commands</b>	VOLT:SLEW

**[SOURce:]VOLTage:SLEW:POSitive****Channel Specific**

This command sets the slew rate of the voltage for positive going transitions. MAXimum sets the slew to the fastest possible rate. MINimum sets the slew to the slowest rate.

<b>Command Syntax</b>	[SOURce:]VOLTage:SLEW:POSitive <NRf+>
<b>Parameters</b>	0 to 9.9E37   MAXimum   MINimum
<b>Unit</b>	V (volts per second)
<b>*RST Value</b>	MAXimum
<b>Examples</b>	VOLT:SLEW:POS 50            VOLT:SLEW:POS MAX
<b>Query Syntax</b>	[SOURce:]VOLTage:SLEW:POSitive?
<b>Returned Parameters</b>	<NR3>
<b>Related Commands</b>	VOLT:SLEW

**[SOURce:]VOLTage:TLEVel****Channel Specific**

This command specifies the transient level of the input voltage. The transient function switches between the immediate setting and the transient level. Refer to Table 4-1 for model-specific programming ranges.

<b>Command Syntax</b>	[SOURce:]VOLTage:TLEVel <NRf+>
<b>Parameters</b>	0 through MAX   MINimum   MAXimum
<b>Unit</b>	V (volts)
<b>*RST Value</b>	MAXimum
<b>Examples</b>	VOLT:TLEV 5            VOLT:TLEV .5
<b>Query Syntax</b>	[SOURce:]VOLTage:TLEVel?
<b>Returned Parameters</b>	<NR3>
<b>Related Commands</b>	VOLT:

**[SOURce:]VOLTage:TRIGgered****Channel Specific**

This command sets the voltage level that will become active when the next trigger occurs.

<b>Command Syntax</b>	[SOURce:]VOLTage[:LEVel]:TRIGgered[:AMPLitude] <NRf+>
<b>Parameters</b>	refer to Specifications Table in User's Guide
<b>Unit</b>	V (volts)
<b>*RST Value</b>	MAXimum
<b>Examples</b>	VOLT:TRIG 120            VOLT:LEV:TRIG 150
<b>Query Syntax</b>	[SOURce:]VOLTage[:LEVel]:TRIGgered[:AMPLitude]?
<b>Returned Parameters</b>	<NR3> (if the trigger level is not programmed, the immediate level is returned)
<b>Related Commands</b>	VOLT    VOLT:MODE

## Measurement Commands

Measurement commands consist of measurement and sense commands.

Two measurement commands are available: MEASure and FETCh. MEASure triggers the acquisition of new data before returning the readings from the array. FETCh returns previously acquired data from the array. Only input current and voltage are actually measured. Power is calculated from the stored voltage and current data. The input voltage and current are digitized whenever a measure command is given or whenever an acquire trigger occurs. The time interval of the measurement is set by SENSE:SWEep:TINTerval, and the position of the trigger relative to the beginning of the data buffer is determined by SENSE:SWEep:OFFSet.

Sense commands control the measurement range, the acquisition sequence, and the measurement window of the electronic load.

### ABORt

This command resets the measurement and list trigger systems to the Idle state. Any measurement or list that is in progress is immediately aborted. ABORt also resets the WTG bit in the Operation Condition Status register (see chapter 3 under “Programming the Status Registers”). ABORt is executed at power turn-on and upon execution of \*RCL, RST, or any implied abort command (see List Commands).

---

**NOTE:** If INITiate:CONTInuous ON has been programmed, the trigger system initiates itself immediately after ABORt, thereby setting the WTG bit.

---

<b>Command Syntax</b>	ABORt
<b>Parameters</b>	None
<b>Examples</b>	ABOR
<b>Related Commands</b>	INIT *RST *TRG TRIG

### MEASure:ARRay:CURRent?

### FETCh:ARRay:CURRent?

#### Channel Specific

These queries return an array containing the instantaneous input current.

<b>Query Syntax</b>	MEASure:ARRay:CURRent[:DC]?	FETCh:ARRay:CURRent[:DC]?
<b>Parameters</b>	None	
<b>Examples</b>	MEAS:ARR:CURR?	FETC:ARR:CURR?
<b>Returned Parameters</b>	4096 NR3 values	
<b>Related Commands</b>	MEAS:ARR:VOLT?	

### MEASure:ARRay:POWer?

### FETCh:ARRay:POWer?

#### Channel Specific

These queries return an array containing the instantaneous input power. The power is calculated from the instantaneous voltage and current data points.

<b>Query Syntax</b>	MEASure:ARRay:POWer[:DC]?	FETCh:ARRay:POWer[:DC]?
<b>Parameters</b>	None	
<b>Examples</b>	MEAS:ARR:POW?	FETC:ARR:POW?
<b>Returned Parameters</b>	4096 NR3 values	
<b>Related Commands</b>	MEAS:ARR:VOLT?	

**MEASure:ARRay:VOLTage?  
FETCh:ARRay:VOLTage?**

**Channel Specific**

These queries return an array containing the instantaneous input voltage.

<b>Query Syntax</b>	MEASure:ARRay:VOLTage[:DC]?	FETCh:ARRay:VOLTage[:DC]?
<b>Parameters</b>	None	
<b>Examples</b>	MEAS:ARR:VOLT?	FETC:ARR:VOLT?
<b>Returned Parameters</b>	4096 NR3 values	
<b>Related Commands</b>	MEAS:ARR:CURR?	

**MEASure:CURRent?  
FETCh:CURRent?**

**Channel Specific**

These queries return the average value of the input current.

<b>Query Syntax</b>	MEASure:[SCALar]:CURRent[:DC]?	FETCh:[SCALar]:CURRent[:DC]?
<b>Parameters</b>	None	
<b>Examples</b>	MEAS:CURR?	FETC:CURR?
<b>Returned Parameters</b>	<NR3>	
<b>Related Commands</b>	MEAS:VOLT?	

**MEASure:CURRent:ACDC?  
FETCh:CURRent:ACDC?**

**Channel Specific**

These queries return the total rms measurement, including the dc portion.

<b>Query Syntax</b>	MEASure:[SCALar]:CURRent:ACDC?	FETCh:[SCALar]:CURRent:ACDC?
<b>Parameters</b>	None	
<b>Examples</b>	MEAS:CURR:ACDC?	FETC:CURR:ACDC?
<b>Returned Parameters</b>	<NR3>	
<b>Related Commands</b>	MEAS:VOLT:ACDC?	MEAS:CURR:AMPL:MAX?

**MEASure:CURRent:MAXimum?  
FETCh:CURRent:MAXimum?**

**Channel Specific**

These queries return the value of the maximum data point in the input current measurement.

<b>Query Syntax</b>	MEASure:[SCALar]:CURRent:MAXimum?	FETCh:[SCALar]:CURRent:MAXimum?
<b>Parameters</b>	None	
<b>Examples</b>	MEAS:CURR:MAX?	FETC:CURR:MAX?
<b>Returned Parameters</b>	<NR3>	
<b>Related Commands</b>	MEAS:CURR:ACDC?	



## MEASure:CURRent:MINimum? FETCh:CURRent:MINimum?

### Channel Specific

These queries return the value of the minimum data point in the input current measurement.

<b>Query Syntax</b>	MEASure:[SCALar]:CURRent:MINimum? FETCh:[SCALar]:CURRent:MINimum?
<b>Parameters</b>	None
<b>Examples</b>	MEAS : CURR : MIN?      FETC : CURR : MIN?
<b>Returned Parameters</b>	<NR3>
<b>Related Commands</b>	MEAS:CURR:ACDC?

## MEASure:POWer? FETCh:POWer?

### Channel Specific

These queries return the average value of the input power in watts.

<b>Query Syntax</b>	MEASure:[SCALar]:POWer[:DC]? FETCh:[SCALar]:POWer[:DC]?
<b>Parameters</b>	None
<b>Examples</b>	MEAS : POW?      FETC : POW?
<b>Returned Parameters</b>	<NR3>
<b>Related Commands</b>	MEAS:POW:MAX?

## MEASure:POWer:MAXimum? FETCh:POWer:MAXimum?

### Channel Specific

These queries return the value of the maximum data point in the input power measurement.

<b>Query Syntax</b>	MEASure:[SCALar]:POWer:MAXimum? FETCh:[SCALar]:POWer:MAXimum?
<b>Parameters</b>	None
<b>Examples</b>	MEAS : POW : MAX?      FETC : POW : MAX?
<b>Returned Parameters</b>	<NR3>
<b>Related Commands</b>	MEAS:POW?    MEAS:POW:MIN?

## MEASure:POWer:MINimum? FETCh:POWer:MINimum?

### Channel Specific

These queries return the value of the minimum data point in the input power measurement.

<b>Query Syntax</b>	MEASure:[SCALar]:POWer:MINimum? FETCh:[SCALar]:POWer:MINimum?
<b>Parameters</b>	None
<b>Examples</b>	MEAS : POW : MIN?      FETC : POW : MIN?
<b>Returned Parameters</b>	<NR3>
<b>Related Commands</b>	MEAS:POW?    MEAS:POW:MAX?

**MEASure:VOLTage?  
FETCh:VOLTage?**

**Channel Specific**

These queries return the average value of the input voltage.

<b>Query Syntax</b>	MEASure:[SCALar]:VOLTage[:DC]? FETCh:[SCALar]:VOLTage[:DC]?
<b>Parameters</b>	None
<b>Examples</b>	MEAS:VOLT?      FETC:VOLT?
<b>Returned Parameters</b>	<NR3>
<b>Related Commands</b>	MEAS:CURR?    MEAS:VOLT:ACDC?

**MEASure:VOLTage:ACDC?  
FETCh:VOLTage:ACDC?**

**Channel Specific**

These queries return the rms value of the input voltage. This returns the total rms measurement, including the dc portion.

<b>Query Syntax</b>	MEASure:[SCALar]:VOLTage:ACDC? FETCh:[SCALar]:VOLTage:ACDC?
<b>Parameters</b>	None
<b>Examples</b>	MEAS:VOLT:ACDC?      FETC:VOLT:ACDC?
<b>Returned Parameters</b>	<NR3>
<b>Related Commands</b>	MEAS:CURR:ACDC?    MEAS:VOLT?

**MEASure:VOLTage:MAXimum?  
FETCh:VOLTage:MAXimum?**

**Channel Specific**

These queries return the maximum value of the input voltage.

<b>Query Syntax</b>	MEASure:[SCALar]:VOLTage:MAXimum? FETCh:[SCALar]:VOLTage:MAXimum?
<b>Parameters</b>	None
<b>Examples</b>	MEAS:VOLT:MAX?      FETC:VOLT:MAX?
<b>Returned Parameters</b>	<NR3>
<b>Related Commands</b>	MEAS:VOLT:ACDC?    MEAS:VOLT?

**MEASure:VOLTage:MINimum?  
FETCh:VOLTage:MINimum?**

**Channel Specific**

These queries return the minimum value of the input voltage.

<b>Query Syntax</b>	MEASure:[SCALar]:VOLTage:MINimum? FETCh:[SCALar]:VOLTage:MINimum?
<b>Parameters</b>	None
<b>Examples</b>	MEAS:VOLT:MIN?      FETC:VOLT:MIN?
<b>Returned Parameters</b>	<NR3>
<b>Related Commands</b>	MEAS:VOLT:ACDC?    MEAS:VOLT?

**SENSe:CURRent:RANGe****Channel Specific**

This command sets the current measurement range. There are two current measurement ranges:

**High Range:** model dependent, see Table 4-1

**Low Range:** model dependent, see Table 4-1

A value of infinity is returned if the measured value is outside the specified current measurement range.

<b>Command Syntax</b>	SENSe:CURRent:RANGe <NRf+>
<b>Parameters</b>	0 through MAX   MINimum   MAXimum
<b>Unit</b>	A (amperes)
<b>*RST Value</b>	MAX (high range)
<b>Examples</b>	SENS:CURR:RANGE MIN
<b>Query Syntax</b>	SENSe:CURRent:RANGe?
<b>Returned Parameters</b>	<NR3>

**SENSe:SWEEp:POINts****Channel Specific**

This command specifies how many data points are taken in any measurement. Applies to both voltage and current measurements. The number of points can be specified, from 1 to 4096.

<b>Command Syntax</b>	SENSe:SWEEp:POINts <NRf+>
<b>Parameters</b>	1 through 4096   MINimum   MAXimum
<b>*RST Value</b>	1000
<b>Examples</b>	SENS:SWE:POIN 2048
<b>Query Syntax</b>	SENSe:SWEEp:POINts?
<b>Returned Parameters</b>	<NR3>
<b>Related Commands</b>	SENS:SWE:TINT MEAS:ARR

**SENSe:SWEEp:OFFSet****Channel Specific**

This command specifies a delay time after the trigger, but before the measurement is taken. The delay is specified in seconds. The measurement offset can be either positive or negative with respect to the trigger.

---

**NOTE:** Negative measurement offsets can only be programmed in conjunction with delayed triggers. The negative measurement offset cannot exceed the trigger delay value.

---

<b>Command Syntax</b>	SENSe:SWEEp:OFFSet <NRf+>
<b>Parameters</b>	0 through 0.032   MINimum   MAXimum
<b>Unit</b>	seconds
<b>*RST Value</b>	0 (zero)
<b>Examples</b>	SENS:SWE:OFFS 0.01
<b>Query Syntax</b>	SENSe:SWEEp:OFFSet?
<b>Returned Parameters</b>	<NR3>
<b>Related Commands</b>	SENS:SWE:TINT MEAS:ARR

**SENSe:SWEep:TINTerval****Channel Specific**

This command defines the time period between measurement points. The time interval can be programmed from 0.00001 to 0.032 seconds in 10 microsecond increments.

<b>Command Syntax</b>	SENSe:SWEep:TINTerval <NRf+>
<b>Parameters</b>	0.00001 - 0.032   MAXimum   MINimum
<b>Unit</b>	seconds
<b>*RST Value</b>	10 $\mu$ s
<b>Examples</b>	SENS:SWE:TINT 100E-6
<b>Query Syntax</b>	SENSe:SWEep:TINTerval?
<b>Returned Parameters</b>	<NR3>
<b>Related Commands</b>	SENS:SWE:OFFS:POIN MEAS:ARR

**SENSe:WINDow****Channel Specific**

This command sets the window function that is used in dc and ac+dc rms measurement calculations. The following functions can be selected:

<b>HANNing</b>	A signal conditioning window that reduces errors in dc and rms measurement calculations in the presence of periodic signals such as line ripple. It also reduces jitter when measuring successive pulses. The Hanning window multiplies each point in the measurement sample by the function $\cos^4$ . Do not use the Hanning window when measuring single-shot pulses.
<b>RECTangular</b>	A window that returns measurement calculations without any signal conditioning.

---

**NOTE:** Neither window function alters the voltage or current data in the measurement array.

---

<b>Command Syntax</b>	SENSe:WINDow[:TYPE] <type>
<b>Parameters</b>	RECTangular   HANNing
<b>*RST Value</b>	RECTangular
<b>Examples</b>	SENS:WIND HANN
<b>Query Syntax</b>	SENSe:WINDow?
<b>Returned Parameters</b>	<CRD>

**SENSe:VOLTage:RANGe****Channel Specific**

This command sets the voltage measurement range. There are two voltage measurement ranges:

**High Range:** model dependent, see Table 4-1

**Low Range:** model dependent, see Table 4-1

A value of infinity is returned if the measured value is outside the specified voltage measurement range.

<b>Command Syntax</b>	SENSe:VOLTage:RANGe[:UPPer] <NRf+>
<b>Parameters</b>	0 through MAX   MINimum   MAXimum
<b>Unit</b>	V (voltage)
<b>*RST Value</b>	MAX (high range)
<b>Examples</b>	SENS:VOLT:RANGE MIN
<b>Query Syntax</b>	SENSe:VOLTage:RANGe?
<b>Returned Parameters</b>	<NR3>
<b>Related Commands</b>	SENS:SWE:TINT MEAS:ARR

## Port Commands

These commands control the general purpose digital port on the electronic load modules.

### PORT0

#### Channel Specific

This command sets the state of the general purpose digital port on the specified electronic load module. A value of 1 sets the state high, a 0 sets the state low.

**Command Syntax** PORT0[:STATe] <bool>  
**Parameters** 0 | 1 | OFF | ON  
**\*RST Value** OFF  
**Examples** PORT0 1            PORT0 ON  
**Query Syntax** PORT0[:STATe]?  
**Returned Parameters** 0 | 1  
**Related Commands** PORT1

### PORT1

This command sets the state of the two general purpose digital ports on the mainframe. The value that you send is the equivalent of a 2-bit binary word. Use the following values to set the individual bits. Note that the digital port on the mainframe can also be programmed using lists.

value	Dig 2	Dig 1
0	Lo	Lo
1	Lo	Hi
2	Hi	Lo
3	Hi	Hi

**Command Syntax** PORT1[:LEVe] <NR1>  
**Parameters** 0 | 1 | 2 | 3  
**\*RST Value** 0  
**Examples** PORT1 1            PORT1 3  
**Query Syntax** PORT1?  
**Returned Parameters** <NR3>  
**Related Commands** PORT0

---

## List Commands

List commands let you program complex sequences of input changes with rapid, precise timing, and synchronized with trigger signals. Each function for which lists can be generated has a list of values that specify the input at each list step. MODE commands such as VOLTage:MODE LIST are used to activate specific functions. LIST:COUNT determines how many times the unit sequences through a list before that list is completed. LIST:DWELL specifies the time interval that each value (step) of a list is to remain in effect. LIST:STEP determines if a trigger causes a list to advance only to its next step or to sequence through all of its steps.

---

**NOTE:** The LIST:DWELL command is active whenever any function is set to list mode. Therefore, a LIST:DWELL time must always be specified whenever any list function is programmed.

---

The list data is given in the list command parameters, which are separated by commas. The order in which the data is entered determines the sequence in which the data is programmed when a list is triggered. Changing list data while a list is running generates an implied ABORT.

All functions that are set to LIST mode must have the same number of steps (up to 50), or an error is generated when the INITiate command is sent. The only exception is a list consisting of only one step. Such a list is treated as if it had the same number of steps as the other lists, with all of the implied step having the same value as the one specified step. All list point data can be stored in nonvolatile memory.

### [SOURce:]LIST:COUNT

This command sets the number of times that the list is executed before it is completed. The command accepts parameters in the range 1 through 9.9E37, but any number greater than 2E9 is interpreted as infinity. Use INFIinity to execute a list indefinitely. This command is not channel specific, it applies to the entire mainframe.

<b>Command Syntax</b>	[SOURce:]LIST:COUNT <NRf+>   INFIinity
<b>Parameters</b>	1 to 9.9E37   MINimum   MAXimum   INFIinity
<b>*RST Value</b>	1
<b>Examples</b>	LIST:COUN 3      LIST:COUN INF
<b>Query Syntax</b>	[SOURce:]LIST:COUNT?
<b>Returned Parameters</b>	<NR3>
<b>Related Commands</b>	LIST:CURR    LIST:FREQ    LIST:TTLT    LIST:VOLT

### [SOURce:]LIST:CURRENT

#### [SOURce:]LIST:CURRENT:POINTS?

##### Channel Specific

This command specifies the current setting for each list step. Refer to Table 4-1 for model-specific programming ranges. LIST:CURRENT:POINTS returns the number of points programmed.

<b>Command Syntax</b>	[SOURce:]LIST:CURRENT[:LEVel] <NRf+> {,<NRf+>}
<b>Parameters</b>	0 through MAX   MINimum   MAXimum
<b>Unit</b>	A (amperes)
<b>Examples</b>	LIST:CURR 2.5,3.0,3.5 LIST:CURR MAX,3.5,2.5,MIN
<b>Query Syntax</b>	[SOURce:]LIST:CURRENT[:LEVel]? [SOURce:]LIST:CURRENT:POINTS?
<b>Returned Parameters</b>	<NR3> {,<NR3>}
<b>Related Commands</b>	CURR

## [SOURce:]LIST:CURRent:RANGe [SOURce:]LIST:CURRent:RANGe:POINts?

### Channel Specific

This command sets the current range for each list step. There are two current ranges.

**High Range:** model dependent, see Table 4-1

**Low Range:** model dependent, see Table 4-1

When you program a range value, the load automatically selects the range that corresponds to the value that you program. If the value falls in a region where ranges overlap, the load selects the range with the highest resolution. LIST:CURRent:RANGe:POINts? returns the number of points programmed.

---

**NOTE:** If the existing IMMEDIATE, TRANsient, and TRIGgered current list settings are outside the new range, a list error is generated when the list is initiated and the list does not execute.

---

<b>Command Syntax</b>	[SOURce:]LIST:CURRent:RANGe <NRf+> {,<NRf+>}
<b>Parameters</b>	0 through MAX   MINimum   MAXimum
<b>Unit</b>	A (amperes)
<b>*RST Value</b>	MAXimum (high range)
<b>Examples</b>	LIST:CURR:RANGE MIN
<b>Query Syntax</b>	[SOURce:]LIST:CURRent:RANGe? [SOURce:]LIST:CURRent:RANGe:POINts?
<b>Returned Parameters</b>	<NR3> {,<NR3>}
<b>Related Commands</b>	CURR:RANG

## [SOURce:]LIST:CURRent:SLEW [SOURce:]LIST:CURRent:SLEW:POINts?

### Channel Specific

This command sets the current slew rate for each step. This command programs both positive and negative going slew rates. MAXimum sets the slew to its fastest possible rate. MINimum sets the slew to its slowest rate. LIST:CURRent:SLEW:POINts? returns the number of points programmed.

<b>Command Syntax</b>	[SOURce:]LIST:CURRent:SLEW[:BOTH] <NRf+> {,<NRf+>}
<b>Parameters</b>	0 to 9.9E37   MAXimum   MINimum
<b>Unit</b>	A (amperes per second)
<b>*RST Value</b>	MAXimum
<b>Examples</b>	LIST:CURR:SLEW 50            LIST:CURR:SLEW MAX
<b>Query Syntax</b>	[SOURce:]LIST:CURRent:SLEW[:BOTH]? [SOURce:]LIST:CURRent:SLEW:POINts?
<b>Returned Parameters</b>	<NR3> {,<NR3>}
<b>Related Commands</b>	CURR:SLEW

**[SOURce:]LIST:CURRENT:SLEW:NEGative****Channel Specific**

This command sets the negative current slew rate for each step. MAXimum sets the slew to its fastest possible rate. MINimum sets the slew to its slowest rate.

<b>Command Syntax</b>	[SOURce:]LIST:CURRENT:SLEW:NEGative <NRf+> {,<NRf+>}
<b>Parameters</b>	0 to 9.9E37   MAXimum   MINimum
<b>Unit</b>	A (amperes per second)
<b>*RST Value</b>	MAXimum
<b>Examples</b>	LIST:CURR:SLEW:NEG 50      LIST:CURR:SLEW:NEG MAX
<b>Query Syntax</b>	[SOURce:]LIST:CURRENT:SLEW:NEGative?
<b>Returned Parameters</b>	<NR3> {,<NR3>}
<b>Related Commands</b>	CURR:SLEW:NEG

**[SOURce:]LIST:CURRENT:SLEW:POSitive****Channel Specific**

This command sets the positive current slew rate for each step. MAXimum sets the slew to its fastest possible rate. MINimum sets the slew to its slowest rate.

<b>Command Syntax</b>	[SOURce:]LIST:CURRENT:SLEW:POSitive <NRf+> {,<NRf+>}
<b>Parameters</b>	0 to 9.9E37   MAXimum   MINimum
<b>Unit</b>	A (amperes per second)
<b>*RST Value</b>	MAXimum
<b>Examples</b>	LIST:CURR:SLEW:POS 50      LIST:CURR:SLEW:POS MAX
<b>Query Syntax</b>	[SOURce:]LIST:CURRENT:SLEW:POSitive?
<b>Returned Parameters</b>	<NR3> {,<NR3>}
<b>Related Commands</b>	CURR:SLEW:POS

**[SOURce:]LIST:CURRENT:TLEVel  
[SOURce:]LIST:CURRENT:TLEVel:POINTs?****Channel Specific**

This command specifies the transient current level for each step. The transient function switches between the immediate setting and the transient level. LIST:CURRENT:TLEVel:POINTs? returns the number of points programmed.

<b>Command Syntax</b>	[SOURce:]LIST:CURRENT:TLEVel <NRf+> {,<NRf+>}
<b>Parameters</b>	refer to Specifications Table in User's Guide
<b>Unit</b>	A (amperes)
<b>*RST Value</b>	MAXimum
<b>Examples</b>	LIST:CURR:TLEV 5      LIST:CURR:TLEV .5
<b>Query Syntax</b>	[SOURce:]LIST:CURRENT:TLEVel? [SOURce:]LIST:CURRENT:TLEVel:POINTs?
<b>Returned Parameters</b>	<NR3> {,<NR3>}
<b>Related Commands</b>	CURR:TLEV



**[SOURCE:]LIST:FUNCTION**  
**[SOURCE:]LIST:MODE**  
**[SOURCE:]LIST:FUNCTION:POINTS?**

**Channel Specific**

These equivalent commands specify the regulation mode for each list step. LIST:FUNCTION:POINTS? returns the number of points programmed.

**CURR** constant current mode  
**RES** constant resistance mode  
**VOLT** constant voltage mode

<b>Command Syntax</b>	[SOURCE:]LIST:FUNCTION <function> {,<function>}
	[SOURCE:]LIST:MODE <function> {,<function>}
<b>Parameters</b>	CURRENT   RESistance   VOLTage
<b>*RST Value</b>	CURRENT
<b>Examples</b>	LIST:FUNC RES, RES, RES, VOLT
<b>Query Syntax</b>	[SOURCE:]LIST:FUNCTION? [SOURCE:]LIST:FUNCTION:POINTS?
<b>Returned Parameters</b>	<CRD> {,<CRD>}
<b>Related Commands</b>	MODE FUNC

**[SOURCE:]LIST:DWELI**  
**[SOURCE:]LIST:DWELI:POINTS?**

This command sets the sequence of list dwell times. Each value represents the time in seconds that the input will remain at the particular list step point before completing the step. At the end of the dwell time, the input of the electronic load depends upon the following conditions:

- ◆ If LIST:STEP AUTO has been programmed, the input automatically changes to the next point in the list.
- ◆ If LIST:STEP ONCE has been programmed, the input remains at the present level until a trigger sequences the next point in the list.

The order in which the points are entered determines the sequence in which they are executed when a list is triggered. Changing list data while a subsystem is in list mode generates an implied ABORT. This command is not channel specific, it applies to the entire mainframe. LIST:DWELI:POINTS? returns the number of points programmed.

<b>Command Syntax</b>	[SOURCE:]LIST:DWELI <NRf+> {,<NRf+>}
<b>Parameters</b>	0 - 10s   MINimum   MAXimum
<b>Unit</b>	s (seconds)
<b>Examples</b>	LIST:DWEL 2.5, 1.5, .5
<b>Query Syntax</b>	[SOURCE:]LIST:DWELI? [SOURCE:]LIST:DWELI:POINTS?
<b>Returned Parameters</b>	<NR3> {,<NR3>}

## [SOURce:]LIST:RESistance [SOURce:]LIST:RESistance:POINts?

### Channel Specific

This command specifies the resistance setting for each list step. Refer to Table 4-1 for model-specific programming ranges. LIST:RESistance:POINts? returns the number of points programmed.

<b>Command Syntax</b>	[SOURce:]LIST:RESistance[:LEVel] <NRf+> {,<NRf+>}
<b>Parameters</b>	0 through MAX   MINimum   MAXimum
<b>Unit</b>	$\Omega$ (ohms)
<b>Examples</b>	LIST:RES 2.5,3.0,3.5 LIST:RES MAX,3.5,2.5,MIN
<b>Query Syntax</b>	[SOURce:]LIST:RESistance[:LEVel]? [SOURce:]LIST:RESistance:POINts?
<b>Returned Parameters</b>	<NR3> {,<NR3>}
<b>Related Commands</b>	RES

## [SOURce:]LIST:RESistance:RANGe [SOURce:]LIST:RESistance:RANGe:POINts?

### Channel Specific

This command sets the resistance range for each list step. There are four resistance ranges, the values of which are model dependent. Refer to Table 4-1 for the resistance ranges of each Electronic Load model.

When you program a range value, the load automatically selects the range that corresponds to the value that you program. If the value falls in a region where ranges overlap, the load selects the range with the highest resolution. LIST:RESistance:RANGe:POINts? returns the number of points programmed.

---

**NOTE:** If the existing IMMEDIATE, TRANSient, and TRIGgered resistance list settings are outside the new range, a list error is generated when the list is initiated and the list does not execute.

---

<b>Command Syntax</b>	[SOURce:]LIST:RESistance:RANGe <NRf+> {,<NRf+>}
<b>Parameters</b>	0 through MAX   MINimum   MAXimum
<b>Unit</b>	$\Omega$ (ohms)
<b>*RST Value</b>	MAXimum (high range)
<b>Examples</b>	LIST:RES:RANGE MIN
<b>Query Syntax</b>	[SOURce:]LIST:RESistance:RANGe? [SOURce:]LIST:RESistance:RANG:POINts?
<b>Returned Parameters</b>	<NR3> {,<NR3>}
<b>Related Commands</b>	RES:RANG

## [SOURce:]LIST:RESistance:SLEW [SOURce:]LIST:RESistance:SLEW:POINTs?

### Channel Specific

This command sets the resistance slew rate for each step. This command programs both positive and negative going slew rates. MAXimum sets the slew to its fastest possible rate. MINimum sets the slew to its slowest rate. LIST:RESistance:SLEW:POINTs? returns the number of points programmed.

<b>Command Syntax</b>	[SOURce:]LIST:RESistance:SLEW[:BOTH] <NRf+> {,<NRf+>}
<b>Parameters</b>	0 to 9.9E37   MAXimum   MINimum
<b>Unit</b>	$\Omega$ (ohms per second)
<b>*RST Value</b>	MAXimum
<b>Examples</b>	LIST:RES:SLEW 50            LIST:RES:SLEW MAX
<b>Query Syntax</b>	[SOURce:]LIST:RESistance:SLEW[:BOTH]? [SOURce:]LIST:RESistance:SLEW:POINTs?
<b>Returned Parameters</b>	<NR3> {,<NR3>}
<b>Related Commands</b>	RES:SLEW

## [SOURce:]LIST:RESistance:SLEW:NEGative

### Channel Specific

This command sets the negative resistance slew rate for each step. MAXimum sets the slew to its fastest possible rate. MINimum sets the slew to its slowest rate.

<b>Command Syntax</b>	[SOURce:]LIST:RESistance:SLEW:NEGative <NRf+> {,<NRf+>}
<b>Parameters</b>	0 to 9.9E37   MAXimum   MINimum
<b>Unit</b>	$\Omega$ (ohms per second)
<b>*RST Value</b>	MAXimum
<b>Examples</b>	LIST:RES:SLEW:NEG 50            LIST:RES:SLEW:NEG MAX
<b>Query Syntax</b>	[SOURce:]LIST:RESistance:SLEW:NEGative?
<b>Returned Parameters</b>	<NR3> {,<NR3>}
<b>Related Commands</b>	RES:SLEW:NEG

## [SOURce:]LIST:RESistance:SLEW:POSitive

### Channel Specific

This command sets the positive resistance slew rate for each step. MAXimum sets the slew to its fastest possible rate. MINimum sets the slew to its slowest rate.

<b>Command Syntax</b>	[SOURce:]LIST:RESistance:SLEW:POSitive <NRf+> {,<NRf+>}
<b>Parameters</b>	0 to 9.9E37   MAXimum   MINimum
<b>Unit</b>	$\Omega$ (ohms per second)
<b>*RST Value</b>	MAXimum
<b>Examples</b>	LIST:RES:SLEW:POS 50            LIST:RES:SLEW:POS MAX
<b>Query Syntax</b>	[SOURce:]LIST:RESistance:SLEW:POSitive?
<b>Returned Parameters</b>	<NR3> {,<NR3>}
<b>Related Commands</b>	RES:SLEW:POS

## [SOURCE:]LIST:RESistance:TLEVel [SOURCE:]LIST:RESistance:TLEVel:POINTs?

### Channel Specific

This command specifies the transient resistance level for each step. The transient function switches between the immediate setting and the transient level. LIST:RESistance:TLEVel:POINTs? returns the number of points programmed.

<b>Command Syntax</b>	[SOURCE:]LIST:RESistance:TLEVel <NRf+> {,<NRf+>}
<b>Parameters</b>	refer to Table 4-1
<b>Unit</b>	$\Omega$ (ohms)
<b>*RST Value</b>	MAXimum
<b>Examples</b>	LIST:RES:TLEV 5      LIST:RES:TLEV .5
<b>Query Syntax</b>	[SOURCE:]LIST:RESistance:TLEVel? [SOURCE:]LIST:RESistance:TLEVel:POINTs?
<b>Returned Parameters</b>	<NR3> {,<NR3>}
<b>Related Commands</b>	RES:TLEV

## [SOURCE:]LIST:STEP

This command specifies how the list sequencing responds to triggers. The following parameters may be specified. This command is not channel specific, it applies to the entire mainframe.

- ONCE**      Causes the list to advance only one point after each trigger. Triggers that arrive during a dwell delay are ignored
- AUTO**      Causes the entire list to be executed sequentially after the starting trigger, paced by its dwell delays. As each dwell delay elapses, the next point is immediately executed.

<b>Command Syntax</b>	[SOURCE:]LIST:STEP <step>
<b>Parameters</b>	ONCE   AUTO
<b>*RST Value</b>	AUTO
<b>Examples</b>	LIST:STEP ONCE
<b>Query Syntax</b>	[SOURCE:]LIST:STEP?
<b>Returned Parameters</b>	<CRD>
<b>Related Commands</b>	LIST:COUN    LIST:DWEL

## [SOURCE:]LIST:TRANSient [SOURCE:]LIST:TRANSient:POINTs?

### Channel Specific

This command turns the transient generator on or off for each step. LIST:TRANSient:POINTs? returns the number of points programmed.

<b>Command Syntax</b>	[SOURCE:]LIST:TRANSient[:STATe] <bool> {,<bool>}
<b>Parameters</b>	0   1   OFF   ON
<b>*RST Value</b>	OFF
<b>Examples</b>	LIST:TRAN 1      LIST:TRAN 0
<b>Query Syntax</b>	[SOURCE:]LIST:TRANSient[:STATe]? [SOURCE:]LIST:TRANSient:POINTs?
<b>Returned Parameters</b>	<NR3> {,<NR3>}
<b>Related Commands</b>	TRAN

## [SOURce:]LIST:TRANSient:DCYCLE [SOURce:]LIST:TRANSient:DCYCLE:POINTS?

### Channel Specific

This command sets the transient duty cycle for each step when the generator is in CONTinuous mode. LIST:TRANSient:DCYCLE:POINTS? returns the number of points programmed.

<b>Command Syntax</b>	[SOURce:]LIST:TRANSient:DCYCLE <NRf+> {,<NRf+>}
<b>Parameters</b>	1.8% - 98.2%   MAXimum   MINimum
<b>Units</b>	<i>percent</i>
<b>*RST Value</b>	50%
<b>Examples</b>	LIST:TRAN:DCYC 10.5      LIST:TRAN:DCYC 50
<b>Query Syntax</b>	[SOURce:]LIST:TRANSient:DCYCLE? [SOURce:]LIST:TRANSient:DCYCLE:POINTS?
<b>Returned Parameters</b>	<NR3> {,<NR3>}
<b>Related Commands</b>	TRAN:DCYC

## [SOURce:]LIST:TRANSient:FREQUENCY [SOURce:]LIST:TRANSient:FREQUENCY:POINTS?

### Channel Specific

This command sets the transient frequency for each step when the generator is in CONTinuous mode. LIST:TRANSient:FREQUENCY:POINTS? returns the number of points programmed.

<b>Command Syntax</b>	[SOURce:]LIST:TRANSient:FREQUENCY <NRf+> {,<NRf+>}
<b>Parameters</b>	0.25Hz - 10kHz   MAXimum   MINimum
<b>Unit</b>	<i>Hertz</i>
<b>*RST Value</b>	MAXimum
<b>Examples</b>	LIST:TRAN:FREQ 50      LIST:TRAN:FREQ 5
<b>Query Syntax</b>	[SOURce:]LIST:TRANSient:FREQUENCY? [SOURce:]LIST:TRANSient:FREQUENCY:POINTS?
<b>Returned Parameters</b>	<NR3> {,<NR3>}
<b>Related Commands</b>	TRAN:FREQ

## [SOURce:]LIST:TRANSient:MODE [SOURce:]LIST:TRANSient:MODE:POINTS?

### Channel Specific

This command selects the transient operating mode for each step. LIST:TRANSient:MODE:POINTS? returns the number of points programmed.

<b>CONTinuous</b>	The transient generator puts out a continuous pulse stream.
<b>PULSe</b>	The transient generator puts out a single pulse upon receipt of a trigger.

<b>Command Syntax</b>	[SOURce:]LIST:TRANSient:MODE <mode> {,<mode>}
<b>Parameters</b>	CONTinuous   PULSe
<b>*RST Value</b>	CONTinuous
<b>Examples</b>	LIST:TRAN:MODE PULS
<b>Query Syntax</b>	[SOURce:]LIST:TRANSient:MODE? [SOURce:]LIST:TRANSient:MODE:POINTS?
<b>Returned Parameters</b>	<CRD> {,<CRD>}
<b>Related Commands</b>	TRAN:MODE

## [SOURce:]LIST:TRANSient:TWIDth

### [SOURce:]LIST:TRANSient:TWIDth:POINTs?

#### Channel Specific

This command sets the transient pulse width for each step when the generator is in PULSe mode. LIST:TRANSient:TWIDth:POINTs? returns the number of points programmed.

<b>Command Syntax</b>	[SOURce:] LIST:TRANSient:TWIDth <NRf+> {,<NRf+>}
<b>Parameters</b>	0.00005s - 4s   MAXimum   MINimum
<b>Unit</b>	seconds
<b>*RST Value</b>	0.0005s
<b>Examples</b>	LIST:TRAN:TWID .005      LIST:TRAN:TWID 5E-4
<b>Query Syntax</b>	[SOURce:]LIST:TRANSient:TWIDth? [SOURce:]LIST:TRANSient:TWIDth:POINTs?
<b>Returned Parameters</b>	<NR3> {,<NR3>}
<b>Related Commands</b>	TRAN:TWID

## [SOURce:]LIST:VOLTage

### [SOURce:]LIST:VOLTage:POINTs?

#### Channel Specific

This command specifies the voltage setting for each list step. Refer to Table 4-1 for model-specific programming ranges. LIST:VOLTage:POINTs? returns the number of points programmed.

<b>Command Syntax</b>	[SOURce:]LIST:VOLTage[:LEVel] <NRf+> {,<NRf+>}
<b>Parameters</b>	0 through MAX   MINimum   MAXimum
<b>Unit</b>	V (volts)
<b>Examples</b>	LIST:VOLT 2.5,3.0,3.5 LIST:VOLT MAX,3.5,2.5,MIN
<b>Query Syntax</b>	[SOURce:]LIST:VOLTage[:LEVel]? [SOURce:]LIST:VOLTage:POINTs?
<b>Returned Parameters</b>	<NR3> {,<NR3>}
<b>Related Commands</b>	VOLT

## [SOURce:]LIST:VOLTage:RANGe

### [SOURce:]LIST:VOLTage:RANGe:POINTs?

#### Channel Specific

This command sets the voltage range for each list step. There are two voltage ranges.

**High Range:** model dependent, see Table 4-1

**Low Range:** model dependent, see Table 4-1

When you program a range value, the load automatically selects the range that corresponds to the value that you program. If the value falls in a region where ranges overlap, the load selects the range with the highest resolution. LIST:VOLTage:RANGe:POINTs? returns the number of points programmed.

---

**NOTE:** If the existing IMMEDIATE, TRANSient, and TRIGgered voltage list settings are outside the new range, a list error is generated when the list is initiated and the list does not execute.

---

<b>Command Syntax</b>	[SOURce:]LIST:VOLTage:RANGe <NRf+> {,<NRf+>}
<b>Parameters</b>	0 through MAX   MINimum   MAXimum
<b>Unit</b>	V (volts)
<b>*RST Value</b>	MAX (high range)
<b>Examples</b>	LIST:VOLT:RANGE MIN
<b>Query Syntax</b>	[SOURce:]LIST:VOLTage:RANGe? [SOURce:]LIST:VOLTage:RANGe:POINTs?
<b>Returned Parameters</b>	<NR3> {,<NR3>}
<b>Related Commands</b>	VOLT:RANG

## [SOURce:]LIST:VOLTage:SLEW

### [SOURce:]LIST:VOLTage:SLEW:POINTs?

#### Channel Specific

This command sets the voltage slew rate for each step. This command programs both positive and negative going slew rates. MAXimum sets the slew to its fastest possible rate. MINimum sets the slew to its slowest rate. LIST:VOLTage:SLEW:POINTs? returns the number of points programmed.

<b>Command Syntax</b>	[SOURce:]LIST:VOLTage:SLEW[:BOTH] <NRf+> {,<NRf+>}
<b>Parameters</b>	0 to 9.9E37   MAXimum   MINimum
<b>Unit</b>	V (volts per second)
<b>*RST Value</b>	MAXimum
<b>Examples</b>	LIST:VOLT:SLEW 50            LIST:VOLT:SLEW MAX
<b>Query Syntax</b>	[SOURce:]LIST:VOLTage:SLEW[:BOTH]? [SOURce:]LIST:VOLTage:SLEW:POINTs?
<b>Returned Parameters</b>	<NR3> {,<NR3>}
<b>Related Commands</b>	VOLT:SLEW

## [SOURce:]LIST:VOLTage:SLEW:NEGative

#### Channel Specific

This command sets the negative voltage slew rate for each step. MAXimum sets the slew to its fastest possible rate. MINimum sets the slew to its slowest rate.

<b>Command Syntax</b>	[SOURce:]LIST:VOLTage:SLEW:NEGative <NRf+> {,<NRf+>}
<b>Parameters</b>	0 to 9.9E37   MAXimum   MINimum
<b>Unit</b>	V (volts per second)
<b>*RST Value</b>	MAXimum
<b>Examples</b>	LIST:VOLT:SLEW:NEG 50            LIST:VOLT:SLEW:NEG MAX
<b>Query Syntax</b>	[SOURce:]LIST:VOLTage:SLEW:NEGative?
<b>Returned Parameters</b>	<NR3> {,<NR3>}
<b>Related Commands</b>	VOLT:SLEW:NEG

**[SOURce:]LIST:VOLTage:SLEW:POSitive****Channel Specific**

This command sets the positive voltage slew rate for each step. MAXimum sets the slew to its fastest possible rate. MINimum sets the slew to its slowest rate.

<b>Command Syntax</b>	[SOURce:]LIST:VOLTage:SLEW:POSitive <NRf+> {,<NRf+>}
<b>Parameters</b>	0 to 9.9E37   MAXimum   MINimum
<b>Unit</b>	V (volts per second)
<b>*RST Value</b>	MAXimum
<b>Examples</b>	LIST:VOLT:SLEW:POS 50      LIST:VOLT:SLEW:POS MAX
<b>Query Syntax</b>	[SOURce:]LIST:VOLTage:SLEW:POSitive?
<b>Returned Parameters</b>	<NR3> {,<NR3>}
<b>Related Commands</b>	VOLT:SLEW:POS

**[SOURce:]LIST:VOLTage:TLEVel**  
**[SOURce:]LIST:VOLTage:TLEVel:POINts?**
**Channel Specific**

This command specifies the transient voltage level for each step. The transient function switches between the immediate setting and the transient level. LIST:VOLTage:TLEVel:POINts? returns the number of points programmed.

<b>Command Syntax</b>	[SOURce:]LIST:VOLTage:TLEVel <NRf+> {,<NRf+>}
<b>Parameters</b>	refer to Table 4-1
<b>Unit</b>	V (volts)
<b>*RST Value</b>	MAXimum
<b>Examples</b>	LIST:VOLT:TLEV 5      LIST:VOLT:TLEV .5
<b>Query Syntax</b>	[SOURce:]LIST:VOLTage:TLEVel? [SOURce:]LIST:VOLTage:TLEVel:POINts?
<b>Returned Parameters</b>	<NR3> {,<NR3>}
<b>Related Commands</b>	VOLT:TLEV



## Transient Commands

These commands program the transient generator of the electronic load. The transient generator programs a second (transient) level at which the electronic load can operate without changing the original programmed settings.

See also [SOURce:]CURRent:TLEVel, [SOURce:]RESistance:TLEVel, and [SOURce:]VOLTage:TLEVel in the Input Commands section.

### [SOURce:]TRANsient

#### Channel Specific

This command turns the transient generator on or off.

<b>Command Syntax</b>	[SOURce:]TRANsient[:STATe] <bool>
<b>Parameters</b>	0   1   OFF   ON
<b>*RST Value</b>	OFF
<b>Examples</b>	TRAN 1      TRAN 0
<b>Query Syntax</b>	[SOURce:]TRANsient[:STATe]?
<b>Returned Parameters</b>	<NR3>
<b>Related Commands</b>	TRAN:MODE      TRAN:FREQ

### [SOURce:]TRANsient:DCYClE

#### Channel Specific

This command sets the duty cycle of each of the transients when the generator is in CONTinuous mode.

<b>Command Syntax</b>	[SOURce:]TRANsient:DCYClE <NRf+>
<b>Parameters</b>	1.8% - 98.2%   MAXimum   MINimum
<b>*RST Value</b>	50%
<b>Unit</b>	<i>percent</i>
<b>Examples</b>	TRAN:DCYC 10.5      TRAN:DCYC 50
<b>Query Syntax</b>	[SOURce:]TRANsient:DCYClE?
<b>Returned Parameters</b>	<NR3>
<b>Related Commands</b>	TRAN:MODE      TRAN:FREQ

### [SOURce:]TRANsient:FREQUency

#### Channel Specific

This command sets the frequency of the transients when the generator is in CONTinuous mode.

<b>Command Syntax</b>	[SOURce:]TRANsient:FREQUency <NRf+>
<b>Parameters</b>	0.25Hz - 10kHz   MAXimum   MINimum
<b>Unit</b>	<i>Hertz</i>
<b>*RST Value</b>	MAXimum
<b>Examples</b>	TRAN:FREQ 50      TRAN:FREQ 5
<b>Query Syntax</b>	[SOURce:]TRANsient:FREQUency?
<b>Returned Parameters</b>	<NR3>
<b>Related Commands</b>	TRAN:DCYC      TRAN

**[SOURce:]TRANSient:MODE****Channel Specific**

This command selects the operating mode of the transient generator as follows.

**CONTinuous** The transient generator puts out a continuous pulse stream.  
**PULSe** The transient generator puts out a single pulse upon receipt of a trigger.  
**TOGGLE** The transient generator toggles between two levels upon receipt of a trigger.

<b>Command Syntax</b>	[SOURce:]TRANSient:MODE <mode>
<b>Parameters</b>	CONTinuous   PULSe   TOGGLE
<b>*RST Value</b>	CONTinuous
<b>Examples</b>	TRAN:MODE FIX
<b>Query Syntax</b>	[SOURce:]TRANSient:MODE?
<b>Returned Parameters</b>	<CRD>
<b>Related Commands</b>	TRAN:DCYC      TRAN

**[SOURce:]TRANSient:LMODE****Channel Specific**

This command selects whether the transient generator uses immediate or list values for the transient settings.

**FIXed** The transient generator uses the fixed or immediate values (set by the TRANSient function commands)  
**LIST** The transient generator uses the transient values programmed by the list.

<b>Command Syntax</b>	[SOURce:]TRANSient:LMODE <mode>
<b>Parameters</b>	FIXed   LIST
<b>*RST Value</b>	FIXed
<b>Examples</b>	TRAN:LMODE FIX
<b>Query Syntax</b>	[SOURce:]TRANSient:LMODE?
<b>Returned Parameters</b>	<CRD>
<b>Related Commands</b>	TRAN:MODE      TRAN

**[SOURce:]TRANSient:TWIDth****Channel Specific**

This command sets the pulse width of the transients when the generator is in PULSe mode.

<b>Command Syntax</b>	[SOURce:]TRANSient:TWIDth <NRf+>
<b>Parameters</b>	0.00005s - 4s   MAXimum   MINimum
<b>Unit</b>	seconds
<b>*RST Value</b>	0.0005s
<b>Examples</b>	TRAN:TWID .005      TRAN:TWID 5E-4
<b>Query Syntax</b>	[SOURce:]TRANSient:TWIDth?
<b>Returned Parameters</b>	<NR3>
<b>Related Commands</b>	TRAN:DCYC      TRAN

## Status Commands

These commands program the electronic load status registers. The electronic load has five groups of status registers; Channel Status, Channel Summary, Questionable Status, Standard Event Status, and Operation Status. Refer to chapter 3 under "Programming the Status Registers" for more information.

### Bit Configuration of Channel Status Registers

Bit Position	15-14	13	12	11	10	9	8	7-5	4	3	2	1	0
Bit Name	N.U.	PS	OV	LRV	UNR	EPU	RRV	N.U.	OT	OP	N.U.	OC	VF
Bit Weight		8192	4096	2048	1024	512	256		16	8	4	2	1
VF	voltage fault has occurred					EPU	extended power unavailable						
OC	over-current condition has occurred					UNR	input is unregulated						
OP	over-power condition has occurred					LRV	reverse voltage on the input terminals						
OT	over-temperature condition has occurred					OV	over-voltage condition has occurred						
RRV	reverse voltage on the sense terminals					PS	protection shutdown circuit has tripped						

### STATus:CHANnel?

#### Channel Specific

This query returns the value of the Channel Event register. The Event register is a read-only register which holds (latches) all events that are passed into it. Reading the Channel Event register clears it.

**Query Syntax** STATus:CHANnel[:EVENT]?  
**Parameters** None  
**Examples** STAT:CHAN:EVENT?  
**Returned Parameters** <NR1> (register value)  
**Related Commands** \*CLS

### STATus:CHANnel:CONDition?

#### Channel Specific

This query returns the value of the Channel Condition register. The particular channel must first be selected by the CHAN command.

**Query Syntax** STATus:CHANnel:CONDition?  
**Parameters** None  
**Examples** STAT:CHAN:COND?  
**Returned Parameters** <NR1> (register value)  
**Related Commands** STAT:CHAN?

### STATus:CHANnel:ENABLE

#### Channel Specific

This command sets or reads the value of the Channel Enable register for a specific channel. The particular channel must first be selected by the CHAN command.

**Command Syntax** STATus:CHANnel:ENABLE <NRf+>  
**Parameters** channel number  
**Examples** STAT:CHAN:ENAB 3  
**Query Syntax** STATus:CHANnel:ENABLE?  
**Returned Parameters** <NR1> (register value)  
**Related Commands** \*CLS

**STATus:CSUM?**

This query returns the value of the Channel Event summary register. The bits in this register correspond to a summary of the channel register for each input channel. Reading the Channel Event summary register clears it. This command is not channel specific, it applies to the entire mainframe.

**Query Syntax** STATus:CSUMmary[:EVENT]?  
**Parameters** None  
**Examples** STAT:CSUM:EVEN?  
**Returned Parameters** <NR1> (register value)  
**Related Commands** \*CLS

**STATus:CSUMmary:ENABLE**

This command sets or reads the value of the Channel Enable summary register. This command is not channel specific, it applies to the entire mainframe.

**Command Syntax** STATus:CSUMmary:ENABLE <NRf+>  
**Parameters** channel number  
**Examples** STAT:CSUM:ENAB 3  
**Query Syntax** STATus:CSUMmary:ENABLE?  
**Returned Parameters** <NR1> (register value)  
**Related Commands** \*CLS

**Bit Configuration of Operation Status Registers**

Bit Position	15–5	5	4–1	0
Bit Name	not used	WTG	not used	CAL
Bit Weight		32		1
CAL = Interface is computing new calibration constants    WTG = Interface is waiting for a trigger.				

**STATus:OPERation?**

This query returns the value of the Operation Event register. The Event register is a read-only register that holds (latches) all events that are passed by the Operation NTR and/or PTR filter. Reading the Operation Event register clears it. This command is not channel specific, it applies to the entire mainframe.

**Query Syntax** STATus:OPERation[:EVENT]?  
**Parameters** None  
**Examples** STAT:OPER:EVEN?  
**Returned Parameters** <NR1> (register value)  
**Related Commands** \*CLS    STAT:OPER:NTR    STAT:OPER:PTR

**STATus:OPERation:CONDition?**

This query returns the value of the Operation Condition register. That is a read-only register that holds the real-time (unlatched) operational status of the electronic load. This command is not channel specific, it applies to the entire mainframe.

**Query Syntax** STATus:OPERation:CONDition?  
**Parameters** None  
**Examples** STAT:OPER:COND?  
**Returned Parameters** <NR1> (register value)  
**Related Commands** STAT:QUES:COND?

**STATus:OPERation:ENABLE**

This command and its query set and read the value of the Operation Enable register. This register is a mask for enabling specific bits from the Operation Event register to set the operation summary bit (OPER) of the Status Byte register. The operation summary bit is the logical OR of all enabled Operation Event register bits. This command is not channel specific, it applies to the entire mainframe.

<b>Command Syntax</b>	STATus:OPERation:ENABLE <NRf+>
<b>Parameters</b>	0 to 32767   MAXimum   MINimum
<b>Default Value</b>	0
<b>Examples</b>	STAT:OPER:ENAB 32            STAT:OPER:ENAB 1
<b>Query Syntax</b>	STATus:OPERation:ENABLE?
<b>Returned Parameters</b>	<NR1> (register value)
<b>Related Commands</b>	STAT:OPER?

**STATus:OPERation:NTRansition**  
**STATus:OPERation:PTRansition**

These commands set or read the value of the Operation NTR (Negative-Transition) and PTR (Positive-Transition) registers. These registers serve as polarity filters between the Operation Enable and Operation Event registers to cause the following actions. This command is not channel specific, it applies to the entire mainframe.

- ◆ When a bit in the Operation NTR register is set to 1, then a 1-to-0 transition of the corresponding bit in the Operation Condition register causes that bit in the Operation Event register to be set.
- ◆ When a bit of the Operation PTR register is set to 1, then a 0-to-1 transition of the corresponding bit in the Operation Condition register causes that bit in the Operation Event register to be set.
- ◆ If the same bits in both NTR and PTR registers are set to 1, then **any transition** of that bit at the Operation Condition register sets the corresponding bit in the Operation Event register.
- ◆ If the same bits in both NTR and PTR registers are set to 0, then **no transition** of that bit at the Operation Condition register can set the corresponding bit in the Operation Event register.

---

**NOTE:**            Setting a bit in the PTR or NTR filter can of itself generate positive or negative events in the corresponding Operation Event register.

---

<b>Command Syntax</b>	STATus:OPERation:NTRansition <NRf+> STATus:OPERation:PTRansition <NRf+>
<b>Parameters</b>	0 to 32767   MAXimum   MINimum
<b>Default Value</b>	0
<b>Examples</b>	STAT:OPER:NTR 32            STAT:OPER:PTR 1
<b>Query Syntax</b>	STATus:OPERation:NTRansition? STATus:OPERation:PTRansition?
<b>Returned Parameters</b>	<NR1> (register value)
<b>Related Commands</b>	STAT:OPER:ENAB

**Bit Configuration of Questionable Status Registers**

Bit Position	15-14	13	12	11	10	9	8	7-5	4	3	2	1	0
Bit Name	N.U.	PS	OV	LRV	UNR	EPU	RRV	N.U.	OT	OP	N.U.	OC	VF
Bit Weight		8192	4096	2048	1024	512	256		16	8	4	2	1
VF	voltage fault has occurred					EPU	extended power unavailable						
OC	over-current condition has occurred					UNR	input is unregulated						
OP	over-power condition has occurred					LRV	reverse voltage on the input terminals						
OT	over-temperature condition has occurred					OV	over-voltage condition has occurred						
RRV	reverse voltage on the sense terminals					PS	protection shutdown circuit has tripped						

**STATus:QUEStionable?**

This query returns the value of the Questionable Event register. The Event register is a read-only register that holds (latches) all events that pass into it. Reading the Questionable Event register clears it. This command is not channel specific, it applies to the entire mainframe.

**Query Syntax** STATus:QUEStionable[:EVENT]?  
**Parameters** None  
**Examples** STAT:QUES:EVENT?  
**Returned Parameters** <NR1> (register value)  
**Related Commands** \*CLS

**STATus:QUEStionable:CONDition?**

This query returns the value of the Questionable Condition register. That is a read-only register that holds the real-time (unlatched) questionable status of the electronic load. This command is not channel specific, it applies to the entire mainframe.

**Query Syntax** STATus:QUEStionable:CONDition?  
**Parameters** None  
**Examples** STAT:QUES:COND?  
**Returned Parameters** <NR1> (register value)  
**Related Commands** STAT:OPER:COND?

**STATus:QUEStionable:ENABLE**

This command sets or reads the value of the Questionable Enable register. This register is a mask for enabling specific bits from the Questionable Event register to set the questionable summary (QUES) bit of the Status Byte register. This bit (bit 3) is the logical OR of all the Questionable Event register bits that are enabled by the Questionable Status Enable register. This command is not channel specific, it applies to the entire mainframe.

**Command Syntax** STATus:QUEStionable:ENABLE <NRf+>  
**Parameters** 0 to 32767 | MAXimum | MINimum  
**Default Value** 0  
**Examples** STAT:QUES:ENAB 32      STAT:QUES:ENAB 1  
**Query Syntax** STATus:QUEStionable:ENABLE?  
**Returned Parameters** <NR1> (register value)  
**Related Commands** STAT:QUES?

## System Commands

System commands control the system-level functions of the electronic load that are not directly related to input control or measurement functions.

### SYSTem:ERRor?

This query returns the next error number followed by its corresponding error message string from the remote programming error queue. The queue is a FIFO (first-in, first-out) buffer that stores errors as they occur. As it is read, each error is removed from the queue. When all errors have been read, the query returns "0, No Error". If more errors are accumulated than the queue can hold, the last error in the queue is "-350, Too Many Errors".

<b>Query Syntax</b>	SYSTem:ERRor?
<b>Parameters</b>	None
<b>Returned Parameters</b>	<NR1>, <SRD>
<b>Examples</b>	SYST:ERR?

### SYSTem:LOCal

This command places the electronic load in local mode during RS-232 operation. The front panel keys are functional.

<b>Command Syntax</b>	SYSTem:LOCal
<b>Parameters</b>	None
<b>Example</b>	SYST:LOC
<b>Related Commands</b>	SYST:REM SYST:RWL

### SYSTem:REMote

This command places the electronic load in remote mode during RS-232 operation. This disables all front panel keys except the Local key. Pressing the Local key while in the remote state returns the front panel to the local state.

<b>Command Syntax</b>	SYSTem:REMote
<b>Parameters</b>	None
<b>Example</b>	SYST:REM
<b>Related Commands</b>	SYST:LOC SYST:RWL

### SYSTem:RWLock

This command places the electronic load in remote mode during RS-232 operation. All front panel keys including the Local key are disabled. Use SYSTem:LOCal to return the front panel to the local state.

<b>Command Syntax</b>	SYSTem:RWLock
<b>Parameters</b>	None
<b>Example</b>	SYST:RWL
<b>Related Commands</b>	SYST:REM SYST:LOC

### SYSTem:VERSion?

This query returns the SCPI version number to which the electronic load complies. The value is of the form YYYY.V, where YYYY is the year and V is the revision number for that year.

<b>Query Syntax</b>	SYSTem:VERSion?
<b>Parameters</b>	None
<b>Examples</b>	SYST:VERS?
<b>Returned Parameters</b>	<NR2>

## Trigger Commands

Trigger commands controls the triggering of the electronic load. Chapter 3 under "Triggering Changes" provides an explanation of the Trigger System.

See also [SOURce:]CURRent:TRIGgered, [SOURce:]RESistance:TRIGgered, and [SOURce:]VOLTage:TRIGgered in the Input Commands section.

---

**NOTE:** The list and measurement commands must first be enabled using the INITiate commands or no action due to triggering will occur. This does not apply to transient triggers.

---

### ABORt

This command resets the list and measurement trigger systems to the Idle state. Any list or measurement that is in progress is immediately aborted. ABORt also resets the WTG bit in the Operation Condition Status register (see chapter 3 under "Programming the Status Registers"). ABORt is executed at power turn-on and upon execution of \*RCL, RST, or any implied abort command (see List Commands).

---

**NOTE:** If INITiate:CONTinuous ON has been programmed, the trigger system initiates itself immediately after ABORt, thereby setting the WTG bit.

---

<b>Command Syntax</b>	ABORt
<b>Parameters</b>	None
<b>Examples</b>	ABOR
<b>Related Commands</b>	INIT *RST *TRG TRIG

### INITiate:SEQUence INITiate:NAME

These equivalent commands prepare the list for the execution of the next trigger. These commands are not channel specific, they apply to the entire mainframe. If the trigger system is not in the Idle state, they are ignored. INITiate:SEQUence references the list sequence by a number, while INITiate:NAME references the list sequence by the name LIST.

Sequence Number	Sequence Name	Description
1 (the default)	LIST	List trigger sequence

<b>Command Syntax</b>	INITiate[:IMMEDIATE]:SEQUence[ 1 ] INITiate[:IMMEDIATE]:NAME LIST
<b>Parameters</b>	For INIT:NAME: LIST
<b>Examples</b>	INIT:SEQ1      INIT:NAME LIST
<b>Related Commands</b>	ABOR INIT:CONT TRIG *TRG

### INITiate:SEQUence2 INITiate:NAME

These equivalent commands prepare the measurement system to take a measurement on the next trigger. These commands are not channel specific, they apply to the entire mainframe. If the trigger system is not in the Idle state, they are ignored. INITiate:SEQUence references the measurement sequence by a number, while INITiate:NAME references the measurement sequence by the name ACQuire.

Sequence Number	Sequence Name	Description
2	ACQuire	Measurement acquire trigger sequence



**Command Syntax** INITiate[:IMMediate]:SEquence2  
 INITiate[:IMMediate]:NAME ACQuire  
**Parameters** For INIT:NAME: ACQuire  
**Examples** INIT:SEQ2      INIT:NAME ACQ  
**Related Commands** ABOR    INIT:CONT    TRIG    \*TRG

## INITiate:CONTInuous:SEquence INITiate:CONTInuous:NAME

These equivalent commands prepare the list to respond to trigger commands. ON or 1 continuously initiates the list. OFF or 0 turns off continuous initiation. Upon the receipt of a trigger with continuous initiation on, one of the following actions occur:

- ◆ If LIST:STEP is set to ONCe, the list will progress to the next step in the sequence.
- ◆ If LIST:STEP is AUTO, each trigger will start the list again.

These commands are not channel specific, they apply to the entire mainframe. If the trigger system is not in the Idle state and therefore already initiated, the initiate commands are ignored.

**Command Syntax** INITiate:CONTInuous:SEquence[1] <bool>  
 INITiate:CONTInuous:NAME LIST, <bool>  
**Parameters** 0 | 1 | OFF | ON  
**Examples** INIT:CONT:SEQ1 ON      INIT:CONT:NAME LIST, 1  
**Related Commands** ABOR    INIT:CONT    TRIG    \*TRG

## TRIGger

When the trigger system has been initiated, this command generates a trigger signal regardless of the selected trigger source. This command is not channel specific, it applies to the entire mainframe.

**Command Syntax** TRIGger[:IMMediate]  
**Parameters** None  
**Examples** TRIG  
**Related Commands** ABOR    TRIG:SOUR    TRIG:DEL    TRIG:TIM

## TRIGger:DELAy

### Channel Specific

This command sets the time delay between the detection of a trigger signal and the start of any corresponding trigger action. After the time delay has elapsed, the trigger is implemented. This command only applies to the selected channel.

**Command Syntax** TRIGger:DELAy <NRf+>  
**Parameters** 0 - 0.032s | MINimum | MAXimum  
**Unit** seconds  
**\*RST Value** 0  
**Examples** TRIG:DEL .025      TRIG:DEL MAX  
**Query Syntax** TRIGger:DELAy?  
**Returned Parameters** <NR3>  
**Related Commands** ABOR    TRIG    TRIG:SOUR    TRIG:TIM

**TRIGger:SEQuence2:COUNT**

This command sets up a successive number of triggers for measuring data. With this command, the trigger system needs to be initialized only once at the start of the acquisition period. After each completed measurement, the instrument waits for the next valid trigger condition to start another measurement. This continues until the count has completed.

<b>Command Syntax</b>	TRIGger:SEQuence2:COUNT<NRf+>
<b>Parameters</b>	1 to 100
<b>*RST Value</b>	1
<b>Examples</b>	TRIG:SEQ2:COUN 5
<b>Query Syntax</b>	TRIGger:SEQuence2:COUNT?
<b>Returned Parameters</b>	<NR3>
<b>Related Commands</b>	TRIG INIT:SEQ

**TRIGger:SOURce**

This command selects the trigger source. This command is not channel specific, it applies to the entire mainframe.

<b>BUS</b>	Accepts a GPIB <GET> signal or a *TRG command as the trigger source. This selection guarantees that all previous commands are complete before the trigger occurs.
<b>EXtErnal</b>	Selects the electronic load's trigger input as the trigger source. This trigger is processed as soon as it is received.
<b>HOLD</b>	Only the TRIG:IMM command will generate a trigger in HOLD mode. All other trigger commands are ignored.
<b>LINE</b>	This generates triggers that are in synchronization with the ac line frequency.
<b>TIMer</b>	This generates triggers that are in synchronization with the electronic load's internal oscillator as the trigger source. The internal oscillator begins running as soon as this command is executed. Use TRIG:TIM to program the oscillator period.

<b>Command Syntax</b>	TRIGger:SOURce <CRD>
<b>Parameters</b>	BUS   EXtErnal   HOLD   LINE   TIMer
<b>*RST Value</b>	HOLD
<b>Examples</b>	TRIG:SOUR BUS      TRIG:SOUR EXT
<b>Query Syntax</b>	TRIGger:SOURce?
<b>Returned Parameters</b>	<CRD>
<b>Related Commands</b>	ABOR TRIG TRIG:DEL TRIG:SYNC

**TRIGger:TIMer**

This command specifies the period of the triggers generated by the internal trigger generator. This command is not channel specific, it applies to the entire mainframe.

<b>Command Syntax</b>	TRIGger:TIMer <NRf+>
<b>Parameters</b>	8 $\mu$ s to 4s   MINimum   MAXimum
<b>Unit</b>	seconds
<b>*RST Value</b>	0.001
<b>Examples</b>	TRIG:TIM .25      TRIG:TIM MAX
<b>Query Syntax</b>	TRIGger:TIMer?
<b>Returned Parameters</b>	<NR3>
<b>Related Commands</b>	ABOR TRIG TRIG:SOUR TRIG:DEL

## Common Commands

Common commands begin with an \* and consist of three letters (command) IEEE 488.2 standard to perform some common interface functions. The electronic loads respond to the required common commands that control status reporting, synchronization, and internal operations. The electronic loads also respond to optional common commands that control triggers, power-on conditions, and stored operating parameters.

Common commands and queries are listed alphabetically. If a command has a corresponding query that simply returns the data or status specified by the command, then both command and query are included under the explanation for the command. If a query does not have a corresponding command or is functionally different from the command, then the query is listed separately. The description for each common command or query specifies any status registers affected. Refer to chapter 3 under "Programming the Status Registers", which explains how to read specific register bits and use the information that they return.

### \*CLS

This command clears the following registers (see chapter 3 under "Programming the Status Registers" for descriptions of all registers):

- ◆ Standard Event Status
- ◆ Operation Status Event
- ◆ Questionable Status Event
- ◆ Status Byte
- ◆ Error Queue

**Command Syntax** \*CLS  
**Parameters** None

### \*ESE

This command programs the Standard Event Status Enable register bits. The programming determines which events of the Standard Event Status Event register (see \*ESR?) are allowed to set the ESB (Event Summary Bit) of the Status Byte register. A "1" in the bit position enables the corresponding event. All of the enabled events of the Standard Event Status Event Register are logically ORed to cause the Event Summary Bit (ESB) of the Status Byte Register to be set. See chapter 3 under "Programming the Status Registers" for descriptions of the Standard Event Status registers.

The query reads the Standard Event Status Enable register.

**Command Syntax** \*ESE <NRf>  
**Parameters** 0 to 255  
**Power-On Value** see \*PSC  
**Examples** \*ESE 129  
**Query Syntax** \*ESE?  
**Returned Parameters** <NR1>  
**Related Commands** \*ESR? \*PSC \*STB?

**Bit Configuration of Standard Event Status Enable Register**

Bit Position	7	6	5	4	3	2	1	0
Bit Name	PON	not used	CME	EXE	DDE	QYE	not used	OPC
Bit Weight	128		32	16	8	4		1
PON	Power-on			DDE	Device-dependent error			
CME	Command error			QYE	Query error			
EXE	Execution error			OPC	Operation complete			

**\*ESR?**

This query reads the Standard Event Status Event register. Reading the register clears it. The bit configuration of this register is the same as the Standard Event Status Enable register (see \*ESE). See chapter 3 under "Programming the Status Registers" for a detailed explanation of this register.

**Query Syntax** \*ESR?  
**Parameters** None  
**Returned Parameters** <NR1> (register value)  
**Related Commands** \*CLS \*ESE \*ESE? \*OPC

**\*IDN?**

This query requests the electronic load to identify itself. It returns the data in four fields separated by commas.

**Query Syntax** \*IDN?  
**Parameters** None  
**Returned Parameters** <AARD>

Field	Information
Agilent Technologies	manufacturer
xxxxA	model number
nnnnA-nnnnn	serial number or 0
<R>.xx.xx	firmware revision

**Example** N&leftrightarrowæ^\ Technologies, N3300A, 0, A.00.01

**\*OPC**

This command causes the interface to set the OPC bit (bit 0) of the Standard Event Status register when the electronic load has completed all pending operations. (See \*ESE for the bit configuration of the Standard Event Status registers.) Pending operations are complete when:

- ◆ All commands sent before \*OPC have been executed. This includes overlapped commands. Most commands are sequential and are completed before the next command is executed. Overlapped commands are executed in parallel with other commands. Commands that affect trigger actions are overlapped with subsequent commands sent to the electronic load. The \*OPC command provides notification that all overlapped commands have been completed.
- ◆ All triggered actions are completed and the trigger system returns to the Idle state.

\*OPC does not prevent processing of subsequent commands but Bit 0 will not be set until all pending operations are completed. The query causes the interface to place an ASCII "1" in the Output Queue when all pending operations are completed.

**Command Syntax** \*OPC  
**Parameters** None  
**Query Syntax** \*OPC?  
**Returned Parameters** <NR1>  
**Related Commands** \*TRIG \*WAI

**\*OPT?**

This query requests the electronic load to identify any options that are installed. Options are identified by number. A 0 indicates no options are installed.

**Query Syntax** \*OPT?  
**Returned Parameters** <AARD>

**\*PSC**

This command controls the automatic clearing at power-on of the Service Request Enable and the Standard Event Status enable registers as follows (see chapter 3 under “Programming the Status Registers” for register details):

- 1 or ON** Prevents the register contents from being saved, causing them to be cleared at power-on. This prevents a PON event from clearing SRQ at power-on.
- 0 or OFF** Saves the contents of the Service Request Enable and the Standard Event Status enable registers in non-volatile memory and recalls them at power-on. This allows a PON event to generate SRQ at power-on.

The query returns the current state of \*PSC.

**Command Syntax** \*PSC <Bool>  
**Parameters** 0 | 1 | OFF | ON  
**Example** \*PSC 0      \*PSC 1  
**Query Syntax** \*PSC?  
**Returned Parameters** 0 | 1  
**Related Commands** \*ESE   \*SRE

**\*RCL**

This command restores the electronic load to a state that was previously stored in memory with a \*SAV command to the specified location. All states are recalled with the following exceptions:

- ◆ CAL:STATe is set to OFF
- ◆ The trigger system is set to the Idle state by an implied ABORt command (this cancels any uncompleted trigger actions)

---

**NOTE:** The device state stored in location 0 is automatically recalled at power turn-on. Lists are only restored if they have been saved in non-volatile memory locations 0, 7, 8, and 9.

---

**Command Syntax** \*RCL <NRf>  
**Parameters** 0 to 9  
**Example** \*RCL 3  
**Related Commands** \*PSC   \*RST   \*SAV

**\*RDT?**

This query reads the model numbers of the modules installed in the mainframe. It returns the data in comma-separated fields.

<b>Query Syntax</b>	*RDT?
<b>Parameters</b>	None
<b>Returned Parameters</b>	model numbers separated by commas
<b>Example</b>	CHAN1:N3302A; CHAN2:N3302A; CHAN3:N3304A

**\*RST**

This command resets **ALL** channels of the electronic load to the following factory-defined states:

CAL:STAT	OFF	[SOUR:]RES	MAX
CHAN	1	[SOUR:]RES:MODE	FIX
INP	ON	[SOUR:]RES:RANG	MAX
INP:SHOR	OFF	[SOUR:]RES:SLEW	MAX
PORT0	OFF	[SOUR:]RES:SLEW:NEG	MAX
PORT1	0	[SOUR:]RES:SLEW:POS	MAX
SENS:CURR:RANG	MAX	[SOUR:]RES:TLEV	MAX
SENS:SWE:POIN	1	[SOUR:]RES:TRIG	MAX
SENS:SWE:OFFS	0	[SOUR:]TRAN	OFF
SENS:SWE:TINT	0.00001	[SOUR:]TRAN:DCYC	50%
SENS:VOLT:RANG	MAX	[SOUR:]TRAN:FREQ	10000
SENS:WIND	RECT	[SOUR:]TRAN:MODE	CONT
[SOUR:]CURR	MIN	[SOUR:]TRAN:TWID	0.0005
[SOUR:]CURR:MODE	FIX	[SOUR:]VOLT	MAX
[SOUR:]CURR:PROT	MAX	[SOUR:]VOLT:MODE	FIX
[SOUR:]CURR:PROT:DEL	15 s	[SOUR:]VOLT:RANG	MAX
[SOUR:]CURR:PROT:STAT	OFF	[SOUR:]VOLT:SLEW	MAX
[SOUR:]CURR:RANG	MAX	[SOUR:]VOLT:SLEW:NEG	MAX
[SOUR:]CURR:SLEW	MAX	[SOUR:]VOLT:SLEW:POS	MAX
[SOUR:]CURR:SLEW:NEG	MAX	[SOUR:]VOLT:TLEV	MAX
[SOUR:]CURR:SLEW:POS	MAX	[SOUR:]VOLT:TRIG	MAX
[SOUR:]CURR:TLEV	MIN	TRIG:DEL	0
[SOUR:]CURR:TRIG	MIN	TRIG:SOUR	HOLD
[SOUR:]FUNC	CURR	TRIG:SEQ2:COUN	1
[SOUR:]LIST:COUN	1	TRIG:TIM	0.001
[SOUR:]LIST:STEP	AUTO		

- 
- NOTE:**
- ◆ \*RST does not clear any of the status registers or the error queue, and does not affect any interface error conditions.
  - ◆ \*RST sets the trigger system to the Idle state.
  - ◆ \*RST clears the presently active list.
- 

<b>Command Syntax</b>	*RST
<b>Parameters</b>	None
<b>Related Commands</b>	*PSC *SAV

**\*SAV**

This command stores the present state of the electronic load to a specified location in memory. Up to 10 states can be stored. States in saved in locations 1-6 are volatile, the data will be lost when power is turned off. States in locations 0, 7, 8, and 9 are nonvolatile, the data will be saved when power is removed. If a particular state is desired at power-on, it should be stored in location 0. It then will be recalled at power-on if the power-on state is set to RCL0. Use \*RCL to retrieve instrument states. Any lists associated with a device state are also saved if they are stored in locations 0, 7, 8, or 9.

---

**NOTE:** \*SAV does not save the programmed trigger values ([SOURce:]CURRent:TRIGGer, [SOURce:]RESistance:TRIGGer, [SOURce:]VOLTage:TRIGGer). Programming an \*RCL or a \*RST command causes the triggered settings to revert to their [IMMEDIATE] settings.

---

**Command Syntax** \*SAV <NRf>  
**Parameters** 0 to 9  
**Example** \*SAV 3  
**Related Commands** \*PSC \*RST \*RCL

**\*SRE**

This command sets the condition of the Service Request Enable Register. This register determines which bits from the Status Byte Register (see \*STB for its bit configuration) are allowed to set the Master Status Summary (MSS) bit and the Request for Service (RQS) summary bit. A 1 in any Service Request Enable Register bit position enables the corresponding Status Byte Register bit and all such enabled bits then are logically ORed to cause Bit 6 of the Status Byte Register to be set.

When the controller conducts a serial poll in response to SRQ, the RQS bit is cleared, but the MSS bit is not. When \*SRE is cleared (by programming it with 0), the electronic load cannot generate an SRQ to the controller. The query returns the current state of \*SRE.

**Command Syntax** \*SRE <NRf>  
**Parameters** 0 to 255  
**Default Value** see \*PSC  
**Example** \*SRE 128  
**Query Syntax** \*SRE?  
**Returned Parameters** <NR1> (register binary value)  
**Related Commands** \*ESE \*ESR \*PSC

**\*STB?**

This query reads the Status Byte register, which contains the status summary bits and the Output Queue MAV bit. Reading the Status Byte register does not clear it. The input summary bits are cleared when the appropriate event registers are read (see chapter 3 under "Programming the Status Registers" for more information). A serial poll also returns the value of the Status Byte register, except that bit 6 returns Request for Service (RQS) instead of Master Status Summary (MSS). A serial poll clears RQS, but not MSS. When MSS is set, it indicates that the electronic load has one or more reasons for requesting service.

**Query Syntax** \*STB?  
**Parameters** None  
**Returned Parameters** <NR1> (register value)  
**Related Commands** \*SRE \*ESR \*ESE

**Bit Configuration of Status Byte Register**

Bit Position	7	6	5	4	3	2	1-0
Bit Name	OPER	MSS/RQS	ESB	MAV	QUES	CSUM	not used
Bit Weight	128	64	32	16	8		
OPER	operation status summary			MAV	message available		
MSS	master status summary			QUES	questionable status summary		
RQS	request for service			CSUM	channel summary		
ESB	event status byte summary						

**\*TRG**

This command generates a trigger to any system that has BUS selected as its source (for example, TRIG:SOUR BUS). The command has the same affect as the Group Execute Trigger (<GET>) command.

**Command Syntax** \*TRG  
**Parameters** None  
**Related Commands** ABOR INIT TRIG:IMM

**\*TST?**

This query causes the electronic load to do a self-test and report any errors.

**Query Syntax** TST?  
**Parameters** None  
**Returned Parameters** <NR1> 0 indicates the electronic load has passed selftest.  
Non-zero indicates an error code (see appendix C)

**\*WAI**

This command instructs the electronic load not to process any further commands until all pending operations are completed. Pending operations are complete when:

- ◆ All commands sent before \*WAI have been executed. This includes overlapped commands. Most commands are sequential and are completed before the next command is executed. Overlapped commands are executed in parallel with other commands. Commands that affect input voltage or state, relays, and trigger actions are overlapped with subsequent commands sent to the electronic load. The \*WAI command prevents subsequent commands from being executed before any overlapped commands have been completed.
- ◆ All triggered actions are completed and the trigger system returns to the Idle state.

\*WAI can be aborted only by sending the electronic load a GPIB DCL (Device Clear) command.

**Command Syntax** WAI?  
**Parameters** None  
**Related Commands** \*OPC



# SCPI Command Tree

## Command Syntax

<b>ABORt</b>	Resets the trigger system to the Idle state
<b>CALibrate</b>	
:DATA <n> {,<n>,<n>}	Enters the calibration data
:IMON:LEVel <points>	Set cal points for current monitor offset (P1   P2)
:IPRog:LEVel <points>	Set cal points for current monitor & programming (P1 P2 P3 P4)
:LEVel <points>	Set cal points for the selected function (P1   P2)
:PASSword <n>	Set calibration password
:SAVE	Save new cal constants in non-volatile memory
:STATE <bool> [,<n>]	Enable or disable calibration mode
<b>CHANnel   INSTRument</b>	
[:LOAD]	Selects a channel in the mainframe
<b>INITiate</b>	
[:IMMediate]	
:SEquence[1]   :SEquence2	Initiates a specific numbered sequence
:NAME LIST   ACQUIRE	Initiates a specific named sequence
<b>CONTinuous</b>	
:SEquence[1] <bool>	Sets continuous initialization
:NAME LIST <bool>	Sets continuous initialization
<b>INPut   OUTput</b>	
[:STATe] <bool>	Enables/disables the input
:PROTection	
:CLEar	Reset latched protection
:SHORT	
[:STATe] <bool>	Enables/disables the input short
<b>MEASure   FETCh</b>	
:ARRay	
:CURRent[:DC]?	Returns the digitized instantaneous current
:POWer[:DC]?	Returns the digitized instantaneous power
:VOLTagE[:DC]?	Returns the digitized instantaneous voltage
[:SCALar]	
:CURRent[:DC]?	Returns the input current
:ACDC?	Returns the total rms current (ac+dc)
:MAX?	Returns maximum current
:MIN?	Returns minimum current
:POWer[:DC]?	Returns the input power measurement
:MAX?	Returns the maximum input power measurement
:MIN?	Returns the minimum input power measurement
:VOLTagE[:DC]?	Returns the input voltage
:ACDC?	Returns the total rms voltage (ac+dc)
:MAX?	Returns maximum voltage
:MIN?	Returns minimum voltage
<b>PORT0 [:STATe] &lt;bool&gt;</b>	Enables/disables the general purpose digital port
<b>PORT1 [:LEVel] &lt;n&gt;</b>	Programs the general purpose digital port

<b>SENSe</b>	
<b>:CURRent</b>	
<b>:RANGe &lt;n&gt;</b>	Selects the current measurement range
<b>:SWEep</b>	
<b>:OFFSet</b>	Defines the data offset in the measurement
<b>:POINts &lt;n&gt;</b>	Define the number of data points in the measurement
<b>:TINTerval &lt;n&gt;</b>	Sets the digitizer sample spacing
<b>:WINDow [:TYPE] &lt;type&gt;</b>	Sets the measurement window function (HANN   RECT)
<b>:VOLTage</b>	
<b>:RANGe &lt;n&gt;</b>	Selects the voltage measurement range
<b>[SOURce:]</b>	
<b>CURRent</b>	
<b>[:LEVel]</b>	
<b>[:IMMediate][:AMPLitude] &lt;n&gt;</b>	Sets the input current
<b>:TRIGgered [:AMPLitude] &lt;n&gt;</b>	Sets the triggered input current
<b>:MODE &lt;mode&gt;</b>	Sets the current mode (FIX   LIST)
<b>:PROTection</b>	
<b>[:LEVel] &lt;n&gt;</b>	Sets the current protection level
<b>:DELay &lt;n&gt;</b>	Sets the delay before the current protection is activated
<b>:STATe &lt;bool&gt;</b>	Enables/disables current limit protection
<b>:RANGe &lt;n&gt;</b>	Sets the input current range
<b>:SLEW</b>	
<b>[:BOTH] &lt;n&gt;</b>	Sets the current slew rate
<b>:NEGative &lt;n&gt;</b>	Sets the current slew rate for negative transitions
<b>:POSitive &lt;n&gt;</b>	Sets the current slew rate for positive transitions
<b>:TLEVel &lt;n&gt;</b>	Sets the transient input current
<b>FUNCTION   MODE &lt;mode&gt;</b>	Sets the regulation mode (CURR   RES   VOLT)
<b>:MODE &lt;mode&gt;</b>	Selects what controls the regulation mode (FIX   LIST)
<b>LIST</b>	
<b>:COUNT &lt;n&gt;</b>	Specifies the number of times the list is cycled
<b>:CURRent</b>	
<b>[:LEVel] &lt;n&gt; {,&lt;n&gt;}</b>	Specifies the current setting for each step
<b>:POINts?</b>	Returns the number of current list points
<b>:RANGe &lt;n&gt; {,&lt;n&gt;}</b>	Specifies the current range for each step
<b>:POINts?</b>	Returns the number of current range list points
<b>:SLEW</b>	
<b>[:BOTH] &lt;n&gt; {,&lt;n&gt;}</b>	Sets the current slew rate for each step
<b>:POINts?</b>	Returns the number of current slew list points
<b>:NEGative &lt;n&gt; {,&lt;n&gt;}</b>	Sets the negative current slew rate for each step
<b>:POSitive &lt;n&gt; {,&lt;n&gt;}</b>	Sets the positive current slew rate for each step
<b>:TLEVel &lt;n&gt; {,&lt;n&gt;}</b>	Sets the transient input current for each step
<b>:POINts?</b>	Returns the number of current transient list points
<b>:DWELl &lt;n&gt; {,&lt;n&gt;}</b>	Specifies the time period of each step
<b>:POINts?</b>	Returns the number of dwell list points
<b>:FUNCTion   MODE &lt;mode&gt; {,&lt;mode&gt;}</b>	Sets the list regulation mode (CURR   RES   VOLT)
<b>:POINts?</b>	Returns the number of function list points
<b>:RESistance</b>	
<b>[:LEVel] &lt;n&gt; {,&lt;n&gt;}</b>	Specifies the resistance setting for each step
<b>:POINts?</b>	Returns the number of resistance list points
<b>:RANGe &lt;n&gt; {,&lt;n&gt;}</b>	Specifies the resistance range for each step
<b>:POINts?</b>	Returns the number of resistance range list points

<b>[SOURCE:]LIST (continued)</b>	
<b>:SLEW</b>	
[:BOTH] <n> {,<n>}	Sets the resistance slew rate for each step
:POINTs?	Returns the number of resistance slew list points
:NEGative <n> {,<n>}	Sets the negative resistance slew rate for each step
:POSitive <n> {,<n>}	Sets the positive resistance slew rate for each step
:TLEVel <n> {,<n>}	Sets the transient resistance for each step
:POINTs?	Returns the number of resistance transient list points
<b>:STEP &lt;step&gt;</b>	Sets the method of incrementing steps (ONCE   AUTO)
<b>:TRANsient</b>	
[:STATE] <bool> {,<bool>}	Enables/disables the transient level for each step
:POINTs?	Returns the number of transient list points
:DCYcle <n> {,<n>}	Sets the transient duty cycle for each step
:POINTs?	Returns the number of transient duty cycle list points
:FREQuency <n> {,<n>}	Sets transient frequency for each step
:POINTs?	Returns the number of transient frequency list points
:MODE <mode> {,<mode>}	Sets the mode of the transient generator (CONT   PULS)
:POINTs?	Returns the number of transient mode list points
:TWIDth <n> {,<n>}	Sets the transient pulse width of each step
:POINTs?	Returns the number of transient pulse width list points
<b>:VOLTage</b>	
[:LEVel] <n> {,<n>}	Specifies the voltage setting for each step
:POINTs?	Returns the number of voltage list points
:RANGe <n> {,<n>}	Specifies the voltage range for each step
:POINTs?	Returns the number of voltage range list points
<b>:SLEW</b>	
[:BOTH] <n> {,<n>}	Sets the voltage slew rate for each step
:POINTs?	Returns the number of voltage slew list points
:NEGative <n> {,<n>}	Sets the negative voltage slew rate for each step
:POSitive <n> {,<n>}	Sets the positive voltage slew rate for each step
:TLEVel <n> {,<n>}	Sets the transient voltage for each step
:POINTs?	Returns the number of voltage transient list points
<b>RESistance</b>	
[:LEVel]	
[:IMMediate][:AMPLitude] <n>	Sets the input resistance
:TRIGgered [:AMPLitude] <n>	Sets the triggered input resistance
:MODE <mode>	Sets the resistance mode (FIX   LIST)
:RANGe <n>	Sets the input resistance range
<b>:SLEW</b>	
[:BOTH] <n>	Sets the resistance slew rate
:NEGative <n>	Sets the resistance slew rate for negative transitions
:POSitive <n>	Sets the resistance slew rate for positive transitions
:TLEVel <n>	Sets the transient input resistance
<b>TRANsient</b>	
[:STATE] <bool>	Enables/disables the transient generator
:DCYcle <n>	Sets transient duty cycle in continuous mode
:FREQuency <n>	Sets transient frequency in continuous mode
:MODE <mode>	Sets the transient mode (CONT   PULS   TOGG )
:LMODE <mode>	Selects transient settings source (FIX   LIST)
:TWIDth <n>	Sets the transient pulse width in pulse mode

<b>[SOURce:](continued)</b>	
<b>VOLTage</b>	
[:LEVel]	
[:IMMediate][:AMPLitude] <n>	Sets the input voltage
:TRIGgered [:AMPLitude] <n>	Sets the triggered input voltage
:MODE <mode>	Sets the voltage mode (FIX  LIST)
:RANGe <n>	Sets the input voltage range
:SLEW	
[:BOTH] <n>	Sets the voltage slew rate
:NEGative <n>	Sets the voltage slew rate for negative transitions
:POSitive <n>	Sets the voltage slew rate for positive transitions
:TLEVel <n>	Sets the transient input voltage
<b>STATus</b>	
:CHANnel	
[:EVENT]?	Returns the value of the channel event register
:CONDition?	Returns the value of the channel condition register
:ENABle <n>	Enables specific bits in the channel event register
:CSUMmary	
[:EVENT]?	Returns the value of the channel summary event register
:ENABle <n>	Enables specific bits in the channel summary event register
:OPERation	
[:EVENT]?	Returns the value of the operation event register
:CONDition?	Returns the value of the operation condition register
:ENABle <n>	Enables specific bits in the operation event register
:NTRansition<n>	Sets the negative transition filter
:PTRansition<n>	Sets the positive transition filter
:QUESTionable	
[:EVENT]?	Returns the value of the event register
:CONDition?	Returns the value of the condition register
:ENABle <n>	Enables specific bits in the Event register
<b>SYSTem</b>	
:ERRor?	Returns the error number and error string
:VERSion?	Returns the SCPI version number
:LOCal	Go to local mode (for RS-232 operation)
:REMote	Go to remote mode (for RS-232 operation)
:RWLock	Go to remote with local lockout (for RS-232 operation)
<b>TRIGger</b>	
[:IMMediate]	Sends a trigger immediately
:DELay	Sets the trigger delay
:SOURce <source>	Sets the trigger source (BUS  EXT   HOLD   LINE   TIM)
:TIMer	Sets the period of the trigger generator.
:SEQuence2	
:COUNt	Specifies the number of triggers that will cause the specified measurement after an INIT command.

## Error Messages

### Error Number List

This appendix gives the error numbers and descriptions that are returned by the electronic load. Error numbers are returned in two ways:

- ◆ Error numbers are displayed on the front panel
- ◆ Error numbers and messages are read back with the `SYSTEM:ERRor?` query. `SYSTEM:ERRor?` returns the error number into a variable and returns two parameters, an NR1 and a string.

The following table lists the errors that are associated with SCPI syntax errors and interface problems. It also lists the device dependent errors. Information inside the brackets is not part of the standard error message, but is included for clarification. When errors occur, the Standard Event Status register records them in bit 2, 3, 4, or 5:

**Table B-1. Error Numbers**

<b>Error #</b>	<b>Error String [Description/Explanation/Examples]</b>
	<b>Command Errors –100 through –199 (sets Standard Event Status Register bit #5)</b>
–100	Command error [generic]
–101	Invalid character
–102	Syntax error [unrecognized command or data type]
–103	Invalid separator
–104	Data type error [e.g., "numeric or string expected, got block data"]
–105	GET not allowed
–108	Parameter not allowed [too many parameters]
–109	Missing parameter [too few parameters]
–112	Program mnemonic too long [maximum 12 characters]
–113	Undefined header [operation not allowed for this device]
–121	Invalid character in number [includes "9" in octal data, etc.]
–123	Numeric overflow [exponent too large; exponent magnitude >32 k]
–124	Too many digits [number too long; more than 255 digits received]
–128	Numeric data not allowed
–131	Invalid suffix [unrecognized units, or units not appropriate]
–138	Suffix not allowed
–141	Invalid character data [bad character, or unrecognized]
–144	Character data too long
–148	Character data not allowed
–150	String data error
–151	Invalid string data [e.g., END received before close quote]
–158	String data not allowed
–160	Block data error
–161	Invalid block data [e.g., END received before length satisfied]

## B – Error Messages

-168	Block data not allowed
-170	Expression error
-171	Invalid expression
-178	Expression data not allowed
<b>Execution Errors –200 through –299 (sets Standard Event Status Register bit #4)</b>	
-200	Execution error [generic]
-221	Settings conflict [check current device state]
-222	Data out of range [e.g., too large for this device]
-223	Too much data [out of memory; block, string, or expression too long]
-224	Illegal parameter value [device-specific]
-225	Out of memory
-270	Macro error
-272	Macro execution error
-273	Illegal macro label
-276	Macro recursion error
-277	Macro redefinition not allowed
<b>System Errors –300 through –399 (sets Standard Event Status Register bit #3)</b>	
-310	System error [generic]
-350	Too many errors [errors beyond 9 lost due to queue overflow]
<b>Query Errors –400 through –499 (sets Standard Event Status Register bit #2)</b>	
-400	Query error [generic]
-410	Query INTERRUPTED [query followed by DAB or GET before response complete]
-420	Query UNTERMINATED [addressed to talk, incomplete programming message received]
-430	Query DEADLOCKED [too many queries in command string]
-440	Query UNTERMINATED [after indefinite response]
<b>Selftest Errors 0 through 99 (sets Standard Event Status Register bit #3)</b>	
0	No error
1	Module Initialization Lost
2	Mainframe Initialization Lost
3	Module Calibration Lost
4	Non-volatile RAM STATE section checksum failed
5	Non-volatile RAM RST section checksum failed
10	RAM selftest
11	CVDAC selftest 1
12	CVDAC selftest 2
13	CCDAC selftest 1
14	CCDAC selftest 2
15	CRDAC selftest 1
16	CRDAC selftest 2
20	Input Down
40	Flash write failed
41	Flash erase failed
80	Digital I/O selftest error
<b>Device-Dependent Errors 100 through 32767 (sets Standard Event Status Register bit #3)</b>	

213	RS-232 buffer overrun error
216	RS-232 receiver framing error
217	RS-232 receiver parity error
218	RS-232 receiver overrun error
220	Front panel uart overrun
221	Front panel uart framing
222	Front panel uart parity
223	Front panel buffer overrun
224	Front panel timeout
401	CAL switch prevents calibration
402	CAL password is incorrect
403	CAL not enabled
404	Computed readback cal constants are incorrect
405	Computed programming cal constants are incorrect
406	Incorrect sequence of calibration commands
407	CV or CC status is incorrect for this command
408	Output mode switch must be in NORMAL position
600	Lists inconsistent [lists have different list lengths]
601	Too many sweep points
602	Command only applies to RS-232 interface
603	FETCH of data that was not acquired
604	Measurement overrange
605	Command not allowed while list initiated
610	Corrupt update data
611	Not Updating





## Comparing N3300A Series Electronic Loads with Earlier Models

### Introduction

The Keysight N3300A Series Electronic Loads covered by this manual are compatible in many ways with the previous HP/Keysight 6050B, 6051B, 60501B, 60502B, 60503B, 60504B, 60507B Electronic Loads. This means that in most cases, programs written for earlier electronic loads will run on the N3300A Series Electronic Loads. However, be aware that there are also many differences between the previous version and the N3300A Series loads that will require you to modify previous electronic load programs.

If you are using Keysight N3300A Series Electronic Loads in test systems or with software designed for 6050B, 6051B, 60501B, 60502B, 60503B, 60504B, 60507B Electronic Loads, you may experience some of the differences documented in Table C-1. If so, refer to the possible reason for the difference in Table C-2 for suggestions on what to do about the difference.

It is not the intent of Table C-2 to provide an exhaustive list of all the differences between previous version electronic loadss and the N3300A Series loads or all possible solutions to problems with previously written software. This table only highlights the areas that affect the behavior of the instrument in normal use.

**NOTE:** For additional information, please contact your Keysight Sales and Support Office listed at the back of the User's Guide.

**Table C-1. Examples of Operating Differences**

Difference Noticed	Possible Reason (see table C-2)
Values read back on the display and over the bus are slightly different than on previous electronic load units.	#1, #2, #3, #4
Values read back on the display and over the bus are significantly different than on previous electronic load units.	#1, #4, #7, #9
Values on front panel display fluctuate more than on previous electronic load units.	#2, #3, #4
Unit unexpectedly turns off; Prot annunciator is on.	#11, #19
Response to analog programming input is different than on previous electronic load units.	#15, #16
Err annunciator comes on when program is run.	#8, #9, #10, #13
Unit under test occasionally behaves unexpectedly.	#1, #7
Trig Out signal has its polarity reversed	#24

**Table C-2. Reasons for Differences**

Item	HP/Keysight Series 6050x	Keysight Series N3300A
<b>1. Command Execution Time</b>	70 milliseconds (typical)	5 milliseconds (typical)
If external equipment is connected to the load, the decreased command execution time of the N3300A Series loads may not allow sufficient settling time for the equipment under test. You may need to insert wait statements in your program if the equipment under test requires a certain amount of settling time after a load change before a measurement can be made.		
<b>2. Voltage Programming and Readback Range</b>	1 range (model dependent): 0-60 volts or 0-150 volts or 0-240 volts	2 ranges (model dependent): 0-6, 0-60 volts or 0-15, 0-150 volts or 0-24, 0-240 volts
The addition of voltage programming and readback ranges provides 16-bit accuracy with the N3300A Series loads. Existing programs may need to be modified to take advantage of the improved accuracy provided with the additional ranges.		
<b>3. Current Readback Range</b>	1 range (model dependent): 0-10 amps or 0-30 amps or 0-60 amps or 0-120 amps	2 ranges (model dependent): 0-1, 0-10 amps or 0-3, 0-30 amps or 0-6, 0-60 amps or 0-12, 0-120 amps
The addition of current readback ranges provides greater accuracy with the N3300A Series loads. Existing programs may need to be modified to take advantage of the improved accuracy provided with the additional ranges.		
<b>4. Measurement Mode</b>	Single measurement occurs at command execution.	Multiple measurements at command execution. Average value is returned. Number of samples and time interval between samples is programmable.
This feature provides greater accuracy and noise immunity when making measurements. The time required to make measurements with the N3300A Series loads may vary considerably, depending on the type of measurement specified. The default measurement settings on the N3300A Series loads are faster than measurements on previous electronic loads.		
<b>5. Programming Accuracy</b> (300W model shown)	Voltage (60V) = 0.1% +50mV Current (60A) = 0.1% +75mA Resistance (1Ω) = 0.8% +8mΩ Resistance (100Ω) = 0.3% +8mS Resistance (10kΩ) = 0.03% +8mS	Voltage (60V) = 0.1% +8mV Current (60A) = 0.1% +15mA Resistance (2Ω) = 0.4% +12mΩ Resistance (20Ω) = 3% +40mΩ Resistance (200Ω) = 20% +120mΩ Resistance (2kΩ) = -50% +2000%
This feature provides greater accuracy with the N3300A Series loads. Existing programs may need to be modified to take advantage of the improved programming accuracy provided with the additional ranges.		
<b>6. Programming Resolution</b> (300W model shown)	Voltage (60V) = 16mV Current (60A) = 16mA Resistance (1Ω) = 0.27mΩ Resistance (100Ω) = 0.27mS Resistance (10kΩ) = 0.027mS	Voltage (60V) = 1mV Current (60A) = 1mA Resistance (2Ω) = 0.035mΩ Resistance (20Ω) = 0.35mΩ Resistance (200Ω) = 3.5mΩ Resistance (2kΩ) = 35mΩ
This feature provides greater accuracy with the N3300A Series loads. Existing programs may need to be modified to take advantage of the improved programming resolution.		

**Table C-2. Differences (continued)**

Item	HP/Keysight Series 6050x	Keysight Series N3300A
<b>7. Mode/Range Change Performance</b>	Firmware turns the input off between mode and range changes.	Firmware does not turn the input off between mode and range changes.
The input is no longer programmed off when modes and ranges change. During mode changes however, limited current or voltage dropouts may still occur. In general, these dropouts may be of a much shorter duration than was the case with previous electronic loads.		
<b>8. Calibration</b>	Calibration procedure for previous loads is documented in the Operating manual.	Refer to the calibration procedure in the N3300A Series User's Guide.
Existing programs must be modified to correctly calibrate the N3300A Series loads.		
<b>9. Resistance Ranges</b> (300W model shown)	3 ranges: 0-1 $\Omega$ , 1-1k $\Omega$ , 10-10k $\Omega$	4 ranges: 0-2 $\Omega$ , 1.8-20 $\Omega$ , 18-200 $\Omega$ , 180-2k $\Omega$ ,
Resistance transients may not work in some cases. For example if you are transitioning from 1 $\Omega$ to 1k $\Omega$ (in previous electronic loads), the command will not work with the resistance ranges in the N3300A Series loads. You can only transition <b>within</b> a specific resistance range (180 $\Omega$ to 2k $\Omega$ for example).		
<b>10. Resistance Slew Rate</b>	1 $\Omega$ range slew rate uses the value programmed for the voltage slew. 1k $\Omega$ and 10k $\Omega$ range slew rate uses the values programmed for the current slew.	Slew rates are programmed in ohms/second. Each resistance range has its own slew rate. Refer to Appendix A in the N3300A Series User's Guide.
The addition of resistance slew rates provides greater capability when programming input resistance. Existing programs must be modified to correctly program resistance slew rates.		
<b>11. UNR Status Reporting</b>	Applied in constant current mode and in 1k $\Omega$ and the 10k $\Omega$ resistance mode.	Applies in all operating modes and ranges.
This feature provides more comprehensive status reporting. Programs that use the UNR status reporting to generate service requests may need to be modified to account for the additional operating modes and ranges that may cause an unregulated status condition to be reported.		
<b>12. *SAV 0 Storage Location</b>	Module settings are saved in individual modules.	All module settings are saved in the mainframe.
This feature saves all power up settings in the mainframe, not the module. This will cause the modules to behave according to the settings stored in each mainframe when swapped. Previous load modules cannot be installed in N3300A Series mainframes. N3300A Series modules cannot be installed in previous mainframes.		
<b>13. Error Messages</b>	Error messages for previous loads are documented in the Operating manual.	Refer to the error message table in the N3300A Series User's Guide.
This feature adds more error messages. Existing programs need to be modified to trap the additional error messages.		
<b>14. Query Response</b>	*IDN? and *RDT? = Hewlett-Packard and earlier model numbers.	*IDN? and *RDT? = Agilent Technologies and N3300A Series model numbers; query number formats may also be different.
This changes the company name and model numbers. Existing programs may need to be modified if the *IDN? and *RDT? queries are used.		

**Table C-2. Differences (continued)**

Item	HP/Keysight Series 6050x	Keysight Series N3300A
<b>15. CC and CV Analog Programming Accuracy</b> (300W model shown)	Current (60A) = 4.5% +75mA Voltage (60V) = 0.8% +200mV	Refer to Appendix A in the N3300A Series User's Guide.
	This feature improves analog programming accuracy in both constant current and in constant voltage mode. Existing programs may need to be modified to take advantage of the improved analog programming accuracy.	
<b>16. CR Analog Programming</b>	Not available	A 0-to-10V signal at the analog programming input corresponds to the minimum to full scale input resistance of the selected resistance range.
	This feature adds analog programming in constant resistance mode. Existing programs will need to be modified to use the analog programming available in constant resistance mode.	
<b>17. List Programming</b>	Not available	Lists containing up to 100 steps can be programmed and downloaded to each electronic load module. They can be run simultaneously in response to an external trigger.
	This feature adds list programming to the current, voltage, resistance, transient, and port functions. Existing programs will need to be modified to use lists. Refer to the N3300A Series User's Guide for details.	
<b>18. Front Panel</b>	<u>Deleted keys</u> Range          Short on/off Tran Level     Tran on/off Slew             Freq Dcycl          Mode	<u>Added keys</u> Ident          Sense Channel        Protect ▲ ▼ Step      ▲ ▼ List             Trigger Func            Trigger Control
	This feature adds additional keys and menus to the front panel. This results in significant differences in front panel operation between previous and N3300A Series loads. Refer to the N3300A Series User's Guide for more information.	
<b>19. Reverse Voltage Protection</b>	Available on input terminals	Available on input and sense terminals
	This feature adds reverse voltage protection on the sense terminals. Load modules will shut down with reverse voltage on remote sense terminals.	
<b>20. Mainframe RS-232 Connector</b>	Not available	An RS-232 connector is available on the 2-pin user-programmable digital output port is available on the back of the mainframe.
	Existing programs must be modified to use the digital port on the mainframe.	
<b>21. Mainframe Digital Port</b>	Not available	A 2-pin user-programmable digital output port is available on the back of the mainframe.
	Existing programs must be modified to use the digital port on the mainframe.	
<b>22. Module Interconnections</b>	3 ribbon cables including ac line distribution.	1 ribbon cable with no ac line distribution.
	Previous load modules cannot be installed in N3300A Series mainframes. N3300A Series modules cannot be installed in previous mainframes.	
<b>23. Line Voltage Selection</b>	Accomplished via internal switches on the mainframe.	No switching required.
	This feature eliminates manual line voltage selection. The line input of the N3300A Series mainframe is rated from 85 - 264 Vac.	
<b>24. Trig Out signal</b>	Trig Out signal is low true.	Trig Out signal is high true.
	The polarity of the Trig Out signal is reversed on the Keysight Series N3300A.	

---

# Index

## —A—

AARD, 19

## —C—

calibration subsystem, 55  
  CALibrate DATA, 55  
  CALibrate IMON LEVel, 55  
  CALibrate IPROg LEVel, 55  
  CALibrate LEVel, 55  
  CALibrate PASSword, 56  
  CALibrate SAVE, 56  
  CALibrate STATe, 56  
channel status group, 41  
channel status registers  
  bit configuration, 89, 92  
channel subsystem, 57  
  CHANnel, 57  
  INSTrument, 57  
character strings, 19  
combine commands  
  common commands, 16  
  from different subsystems, 16  
  root specifier, 16  
command completion, 19  
common command syntax, 54  
common commands, 97  
  \*CLE, 97  
  \*ESE, 97  
  \*ESR?, 98  
  \*IDN?, 98  
  \*OPC, 98  
  \*OPT?, 99  
  \*PSC, 99  
  \*RCL, 99  
  \*RDT?, 100  
  \*RST, 100  
  \*SAV, 101  
  \*SRE, 101  
  \*STB?, 101  
  \*TRG, 102  
  \*TST?, 102  
  \*WAI, 102  
compatibility  
  commands, 112  
  language, 111  
conventions used in this guide, 15  
CRD, 19  
current, 24  
  maximum, 24  
  measurement range, 32  
  measurements, 31

## —D—

dc measurements, 31  
delaying triggers, 30  
determining cause of interrupt, 43  
device clear, 20  
DTR-DSR, 14

## —E—

enabling the output, 23  
error numbers, 107

## —F—

fetch commands, 31

## —G—

generating measurement triggers, 34  
generating triggers, 30  
GPIB  
  command library for MS DOS, 10  
  controller programming, 10  
  IEEE Std for standard codes, 10  
  IEEE Std for standard digital interface, 10  
GPIB References, 10

## —H—

Hanning, 74  
header, 17  
  long form, 17  
  short form, 17  
history, 2  
HP-IB  
  address, 13  
  capabilities of the dc source, 13

## —I—

initialization, 23  
initiating list triggers, 30  
initiating measurement trigger system, 34  
input subsystem, 58  
  INPut, 58  
  INPut PROTection CLear, 58  
  INPut SHORt, 58  
  OUTPut, 58  
  OUTPut PROTection CLear, 58  
  OUTPut SHORt, 58  
internally triggered measurements, 33

## Index

### —L—

language, 111  
language dictionary, 53  
list transients, 28  
list trigger system model, 29  
lists, 26  
    programming, 26

### —M—

making measurements, 31  
MAV bit, 43  
maximum measurements, 32  
measure commands, 31  
measurement subsystem, 69  
    FETCh ARRy CURRent STEP?, 69  
    FETCh ARRy CURRent?, 69  
    FETCh ARRy POWer STEP?, 69  
    FETCh ARRy POWer?, 69  
    FETCh ARRy VOLTage STEP?, 70  
    FETCh ARRy VOLTage?, 70  
    FETCh CURRent ACDC STEP?, 70  
    FETCh CURRent ACDC?, 70  
    FETCh CURRent MAXimum STEP?, 70  
    FETCh CURRent MAXimum?, 70  
    FETCh CURRent MINimum STEP?, 71  
    FETCh CURRent MINimum?, 71  
    FETCh CURRent STEP?, 70  
    FETCh CURRent?, 70  
    FETCh POWer MAXimum STEP?, 71  
    FETCh POWer MAXimum?, 71  
    FETCh POWer MINimum STEP?, 71  
    FETCh POWer MINimum?, 71  
    FETCh POWer STEP?, 71  
    FETCh POWer?, 71  
    FETCh VOLTage ACDC STEP?, 72  
    FETCh VOLTage ACDC?, 72  
    FETCh VOLTage MAXimum STEP?, 72  
    FETCh VOLTage MAXimum?, 72  
    FETCh VOLTage MINimum STEP?, 72  
    FETCh VOLTage MINimum?, 72  
    FETCh VOLTage STEP?, 72  
    FETCh VOLTage?, 72  
    MEASure ARRy CURRent?, 69  
    MEASure ARRy POWer?, 69  
    MEASure ARRy VOLTage?, 70  
    MEASure CURRent ACDC?, 70  
    MEASure CURRent MAXimum?, 70  
    MEASure CURRent MINimum?, 71  
    MEASure CURRent?, 70  
    MEASure POWer MAXimum?, 71  
    MEASure POWer MINimum?, 71  
    MEASure POWer?, 71  
    MEASure VOLTage ACDC?, 72  
    MEASure VOLTage MAXimum?, 72  
    MEASure VOLTage MINimum?, 72  
    MEASure VOLTage?, 72  
measurement trigger system model, 33  
message terminator, 18  
    end or identify, 18

    newline, 18  
message unit  
    separator, 18  
minimum measurements, 32  
moving among subsystems, 16  
MSS bit, 42  
multiple measurements, 35

### —N—

numerical data formats, 18

### —O—

OCP, 24  
operation status group, 42  
optional header  
    example, 16  
output queue, 43  
overcurrent protection, 24

### —P—

PON (power on) bit, 42  
port subsystem, 75  
    PORT0, 75  
    PORT1, 75  
power-on conditions, 41  
power-on initialization, 23  
print date, 2  
programming parameters, 54  
programming status registers, 36, 38, 44  
programming the output, 23

### —Q—

queries, 17  
query  
    indicator, 18  
questionable status group, 41

### —R—

Rectangular, 74  
returning voltage or current data, 32  
rms measurements, 32  
root specifier, 18  
RQS bit, 42  
RS-232  
    capabilities of the dc source, 14  
    data format, 14, 20  
    data terminator, 18  
    flow control, 14  
RTS-CTS, 14

### —S—

safety summary, 2  
SCPI  
    command completion, 19

- command syntax, 53
- command tree, 15
- common commands, 15
- conformance, 21
- data format, 18
- device clear, 20
- header path, 16
- message structure, 17
- message types, 17
- message unit, 17
- multiple commands, 16
- non-conformance, 21
- program message, 17
- response message, 17
- subsystem commands, 15, 53
- triggering nomenclature, 29, 33
- SCPI References, 9
- sense subsystem, 76
  - SENSe CURRent RANGe, 73
  - SENSe SWEEp OFFSet, 73
  - SENSe SWEEp POINts, 73
  - SENSe SWEEp TINTerval, 74
  - SENSe SWEEp WINDow, 74
  - SENSe VOLTage RANGe, 74
  - SENSe WINDow, 74
- servicing operation status, 43
- servicing questionable status events, 43
- setting output trigger system, 24
- source subsystem
  - CURRent, 59
  - CURRent MODE, 59
  - CURRent PROTection, 59
  - CURRent PROTection DELay, 60
  - CURRent PROTection STATe, 60
  - CURRent RANGe, 60
  - CURRent SLEW, 61
  - CURRent SLEW NEGative, 61
  - CURRent SLEW POSitive, 61
  - CURRent TLEVel, 62
  - CURRent TRIGgered, 62
  - FUNcTION, 62
  - FUNcTION MODE, 63
  - LIST COUNT, 76
  - LIST CURRent, 76
  - LIST CURRent POINts, 76
  - LIST CURRent RANGe, 77
  - LIST CURRent RANGe POINts, 77
  - LIST CURRent SLEW, 77
  - LIST CURRent SLEW NEGative, 78
  - LIST CURRent SLEW POINts?, 77
  - LIST CURRent SLEW POSitive, 78
  - LIST CURRent TLEVel, 78
  - LIST CURRent TLEVel POINts?, 78
  - LIST DWELl, 79
  - LIST DWELl POINts?, 79
  - LIST FUNcTION, 79
  - LIST FUNcTION POINts?, 79
  - LIST MODE, 79
  - LIST RESistance, 80
  - LIST RESistance POINts?, 80
  - LIST RESistance RANGe, 80
  - LIST RESistance RANGe POINts?, 80
  - LIST RESistance SLEW, 81
  - LIST RESistance SLEW NEGative, 81
  - LIST RESistance SLEW POINts?, 81
  - LIST RESistance SLEW POSitive, 81
  - LIST RESistance TLEVel, 82
  - LIST RESistance TLEVel POINts?, 82
  - LIST STEP, 82
  - LIST TRANsient, 82
  - LIST TRANsient DCYClE, 83
  - LIST TRANsient DCYClE POINts?, 83
  - LIST TRANsient FREQuency, 83
  - LIST TRANsient FREQuency POINts?, 83
  - LIST TRANsient MODE, 83
  - LIST TRANsient MODE POINts?, 83
  - LIST TRANsient POINts, 82
  - LIST TRANsient TWIDth, 84
  - LIST TRANsient TWIDth POINts?, 84
  - LIST VOLTage, 84
  - LIST VOLTage POINts?, 84
  - LIST VOLTage RANGe, 85
  - LIST VOLTage RANGe POINts?, 85
  - LIST VOLTage SLEW, 85
  - LIST VOLTage SLEW NEGative, 85
  - LIST VOLTage SLEW POINts?, 85
  - LIST VOLTage SLEW POSitive, 86
  - LIST VOLTage TLEVel, 86
  - LIST VOLTage TLEVel POINts?, 86
  - MODE, 62
  - RESistance, 63
  - RESistance MODE, 63
  - RESistance RANGe, 64
  - RESistance SLEW, 64
  - RESistance SLEW NEGative, 64
  - RESistance SLEW POSitive, 65
  - RESistance TLEVel, 65
  - RESistance TRIGgered, 65
  - TRANsient, 87
  - TRANsient DCYClE, 87
  - TRANsient FREQuency, 87
  - TRANsient LMODE, 88
  - TRANsient MODE, 88
  - TRANsient TWIDth, 88
  - VOLTage, 66
  - VOLTage MODE, 66
  - VOLTage RANGe, 64, 67
  - VOLTage SLEW, 67
  - VOLTage SLEW NEGative, 67
  - VOLTage SLEW POSitive, 68
  - VOLTage TLEVel, 68
  - VOLTage TRIGgered, 68
- source subsystem, list, 76
- source subsystem, transient, 87
- SRD, 19
- standard event status enable register
  - bit configuration, 98
- standard event status group, 41
- status bit configurations**, 38, 39
- status byte register, 42
  - bit configuration, 102
- status model, 41

## Index

status operation registers

bit configuration, 90

status subsystem, 89

STATus CHANnel CONDition?, 89

STATus CHANnel ENABle, 89

STATus CHANnel?, 89

STATus CSUMmary ENABle, 90

STATus CSUMmary?, 90

STATus OPERation CONDition?, 90

STATus OPERation ENABle?, 91

STATus OPERation NTRansition, 91

STATus OPERation PTRansition, 91

STATus OPERation?, 90

STATus QUEStionable CONDition?, 92

STATus QUEStionable ENABle, 92

STATus QUEStionable?, 92

suffixes, 19

system commands

SYST LANG, 111

SYST LOC, 93

SYST REM, 93

SYST RWL, 93

SYSTem ERRor?, 93

SYSTem VERSion?, 93

system errors, 107

### —T—

transients, 25

continuous, 25

multiple channels, 28

programming, 25

pulse, 25

toggled, 26

trigger subsystem, 94

ABORt, 69, 94

INITiate ACQuire, 94

INITiate CONTinuous LIST, 95

INITiate CONTinuous SEQuence, 95

INITiate LIST, 94

INITiate SEQuence, 94

INITiate SEQuence2, 94

TRIGger, 95

TRIGger DELay, 95

TRIGger SEQuence2

COUNt, 96

TRIGger SOURce, 96

TRIGger TIMER, 96

triggering output changes, 29

triggers

continuous, 30

single, 30

types of SCPI commands, 15

### —V—

varying voltage or current sampling, 35

voltage, 23

maximum, 24

measurements, 31

### —W—

waiting for measurement results, 34

### —X—

XON-XOFF, 14





This information is subject to change without notice.  
© Keysight Technologies 2000, 2002, 2014  
Edition 3, November 2014



5964-8198

[www.keysight.com](http://www.keysight.com)