

Keysight N9912A RF Analyzer

(2 MHz - 4 GHz)
(2 MHz - 6 GHz)

Notice: This document contains references to Agilent. Please note that Agilent's Test and Measurement business has become Keysight Technologies. For more information, go to www.keysight.com.

Notices

© Keysight Technologies, Inc.
2008-2018

No part of this manual may be reproduced in any form or by any means (including electronic storage and retrieval or translation into a foreign language) without prior agreement and written consent from Keysight Technologies, Inc. as governed by United States and international copyright laws.

Trademark Acknowledgments

Manual Part Number

N9912-90003

Edition

August 24, 2018

Printed in USA/Malaysia

Published by:
Keysight Technologies
1400 Fountaingrove Parkway
Santa Rosa, CA 95403

Warranty

THE MATERIAL CONTAINED IN THIS DOCUMENT IS PROVIDED "AS IS," AND IS SUBJECT TO BEING CHANGED, WITHOUT NOTICE, IN FUTURE EDITIONS. FURTHER, TO THE MAXIMUM EXTENT PERMITTED BY APPLICABLE LAW, KEYSIGHT DISCLAIMS ALL WARRANTIES, EITHER EXPRESS OR IMPLIED WITH REGARD TO THIS MANUAL AND ANY INFORMATION CONTAINED HEREIN, INCLUDING BUT NOT LIMITED TO THE IMPLIED WARRANTIES OF MERCHANTABILITY AND FITNESS FOR A PARTICULAR PURPOSE. KEYSIGHT SHALL NOT BE LIABLE FOR ERRORS OR FOR INCIDENTAL OR CONSEQUENTIAL DAMAGES IN CONNECTION WITH THE FURNISHING, USE, OR PERFORMANCE OF THIS DOCUMENT OR ANY INFORMATION CONTAINED HEREIN. SHOULD KEYSIGHT AND THE USER HAVE A SEPARATE WRITTEN AGREEMENT WITH WARRANTY TERMS COVERING THE MATERIAL IN THIS

DOCUMENT THAT CONFLICT WITH THESE TERMS, THE WARRANTY TERMS IN THE SEPARATE AGREEMENT WILL CONTROL.

Technology Licenses

The hardware and/or software described in this document are furnished under a license and may be used or copied only in accordance with the terms of such license.

U.S. Government Rights

The Software is "commercial computer software," as defined by Federal Acquisition Regulation ("FAR") 2.101. Pursuant to FAR 12.212 and 27.405-3 and Department of Defense FAR Supplement ("DFARS") 227.7202, the U.S. government acquires commercial computer software under the same terms by which the software is customarily provided to the public.

Accordingly, Keysight provides the Software to U.S. government customers under its standard commercial license, which is embodied in its End User License Agreement (EULA), a copy of which can be found at

<http://www.keysight.com/find/sweula>

The license set forth in the EULA represents the exclusive authority by which the U.S. government may use, modify, distribute, or disclose the Software. The EULA and the license set forth therein, does not require or permit, among other things, that Keysight: (1) Furnish technical information related to commercial computer software or commercial computer software documentation that is not customarily provided to the public; or (2) Relinquish to, or otherwise provide, the government rights in excess of these rights customarily provided to the public to use, modify, reproduce, release, perform, display, or disclose commercial computer software or commercial computer software documentation. No additional

government requirements beyond those set forth in the EULA shall apply, except to the extent that those terms, rights, or licenses are explicitly required from all providers of commercial computer software pursuant to the FAR and the DFARS and are set forth specifically in writing elsewhere in the EULA. Keysight shall be under no obligation to update, revise or otherwise modify the Software. With respect to any technical data as defined by FAR 2.101, pursuant to FAR 12.211 and 27.404.2 and DFARS 227.7102, the U.S. government acquires no greater than Limited Rights as defined in FAR 27.401 or DFAR 227.7103-5 (c), as applicable in any technical data.

Safety Notices

CAUTION

A CAUTION notice denotes a hazard. It calls attention to an operating procedure, practice, or the like that, if not correctly performed or adhered to, could result in damage to the product or loss of important data. Do not proceed beyond a CAUTION notice until the indicated conditions are fully understood and met.

WARNING

A WARNING notice denotes a hazard. It calls attention to an operating procedure, practice, or the like that, if not correctly performed or adhered to, could result in personal injury or death. Do not proceed beyond a WARNING notice until the indicated conditions are fully understood and met.

Where to Find the Latest Information

Documentation is updated periodically. For the latest information about these products, including instrument software upgrades, application information, and product information, browse to one of the following URLs, according to the name of your product:

<http://www.keysight.com/find/pxa>

<http://www.keysight.com/find/mxa>

<http://www.keysight.com/find/exa>

<http://www.keysight.com/find/cxa>

<http://www.keysight.com/find/mxe>

To receive the latest updates by email, subscribe to Keysight Email Updates at the following URL:

<http://www.keysight.com/find/MyKeysight>

Information on preventing instrument damage can be found at:

www.keysight.com/find/PreventingInstrumentRepair

Is your product software up-to-date?

Periodically, Keysight releases software updates to fix known defects and incorporate product enhancements. To search for software updates for your product, go to the Keysight Technical Support website at:

<http://www.keysight.com/find/techsupport>

Table of Contents

1. Safety and Regulatory Information

Information in This Chapter 1-1
 Chapter One at-a-Glance 1-1
 Safety Symbols 1-2
 General Safety Considerations 1-3
 Safety Earth Ground 1-3
 Before Applying Power 1-3
 Servicing 1-3
 Electrostatic Discharge Protection 1-5
 Regulatory Information 1-7
 Instrument Markings 1-7
 Battery Disposal 1-8

2. General Product Information

Information in This Chapter 2-1
 Chapter Two at-a-Glance 2-1
 Maintenance 2-2
 Physical Maintenance 2-2
 Electrical Maintenance 2-2
 Analyzer Options 2-3
 Option 110, Transmission Measurement 2-3
 Option 111, QuickCal 2-3
 Option 230, 4 GHz Spectrum Analyzer 2-3
 Option 231, 6 GHz Spectrum Analyzer 2-3
 Option 235, Preamplifier for Spectrum Analyzer 2-3
 Option 302, External USB Power Sensor Support 2-3
 Option 303, Network Analyzer Capability 2-3
 Keysight Support, Services, and Assistance 2-4
 Service and Support Options 2-4
 Calibration Options 2-4
 Contacting Keysight 2-5
 Shipping Your Analyzer to Keysight for Service or Repair 2-5

3. Tests and Adjustments

Information in This Chapter 3-1
 Chapter Three at-a-Glance 3-1
 Before You Begin 3-3
 Protect Against Electrostatic Discharge (ESD) 3-3

Contents

Allow the Analyzer to Warm Up	3-3
Review the Principles of Connector Care	3-3
Service Test Equipment	3-5
Before Returning an Instrument to a Customer	3-6
Operational Check	3-7
Performance Tests (Keysight N7841A Software Package)	3-8
General Tests	3-8
Spectrum Analyzer Specific Tests	3-8
Adjustments (Keysight N7841A Software Package)	3-9
General Adjustments	3-9
Spectrum Analyzer Specific Adjustments	3-9
4. Troubleshooting	
Information in This Chapter	4-1
Chapter Four at-a-Glance	4-1
Protect Against Electrostatic Discharge (ESD)	4-2
Assembly Replacement Sequence	4-3
Getting Started with Troubleshooting	4-4
Check the Basics	4-4
Troubleshooting Organization	4-4
Power Up Troubleshooting	4-6
Front Panel Group Troubleshooting	4-7
Measurement Group Troubleshooting	4-8
5. Theory of Operation	
Information in This Chapter	5-1
Chapter Five at-a-Glance	5-1
Analyzer System Operation	5-2
Functional Groups of the Analyzer	5-2
Front Panel Group	5-4
A3 Front Panel Interface Board	5-4
A2 LCD Assembly	5-5
Measurement Group	5-6
A4 RF Board	5-6
A5 System Board	5-10
A6 SOM Board	5-15
Main Battery	5-15
Grounding and Power	5-16
Grounding	5-16
Voltages and Power Supplies	5-16

Power Control and Management	5-17
Battery Related Information	5-18
Operation in Modes	5-20
CAT and NA Modes	5-21
SA Mode	5-24
Power Meter Mode	5-25
Temperature Related Information	5-26
User Calibration in CAT and NA Modes	5-27
One Port Calibration	5-27
Two Port Calibration	5-28
QuickCal	5-28
Firmware Related Information	5-29
General Description	5-29
User Accessible Files	5-29
Operational Files	5-29
Erase User Data Utility	5-30
Error Log	5-30
Firmware Upgrades	5-30
LAN Interface	5-31
6. Replaceable Parts	
Information in This Chapter	6-1
Chapter Six at-a-Glance	6-1
Ordering Information	6-2
Assembly Replacement Procedure	6-3
Replaceable Parts Listings	6-4
Entire Analyzer	6-4
Front Panel Group	6-5
Measurement Group	6-7
Case Group	6-10
Miscellaneous Parts	6-12
7. Repair and Replacement Procedures	
Information in This Chapter	7-1
Chapter Seven at-a-Glance	7-1
Personal Safety Warnings	7-2
Safety Earth Ground	7-2
Electrostatic Discharge (ESD) Protection	7-3
Assembly Replacement Sequence	7-4
Removal and Replacement Procedures	7-5

Contents

Removing and Replacing the Main Battery	7-6
Removing and Replacing the Case Group Parts.	7-7
Removing and Replacing the Front Panel Group Assemblies	7-21
Removing and Replacing the Measurement Group Assemblies.	7-29
Post-Repair Procedures.	7-44
Manual Checks and Procedures	7-44
Processor Upgrade Procedures.	7-46
8. General Purpose Maintenance and Service Procedures	
Information in This Chapter.	8-1
Chapter Eight at-a-Glance	8-1
Service Related User Operations	8-2
To View Currently Installed Options	8-2
To View the Current Firmware Revision, Etc.	8-2
To View the Error Log	8-2
To View Temperature Readings.	8-2
Erase User Data Utility	8-3
Options.	8-4
To View Currently Installed Options	8-4
Re-Installing Options.	8-4
Firmware Upgrades	8-6
To Check the Current Firmware Revision	8-6
Miscellaneous Service and Maintenance	8-7
Cleaning the Display	8-7
Battery Maintenance	8-7

1 Safety and Regulatory Information

Information in This Chapter

This chapter provides safety information that will help protect you and your network analyzer. It also contains information that is required by various government regulatory agencies.

Chapter One at-a-Glance

Section Title	Summary of Content	Start Page
Safety Symbols	Descriptions of CAUTION and WARNING symbols used throughout this manual.	page 1-2
General Safety Considerations	A list of safety points to consider when servicing your network analyzer.	page 1-3
Electrostatic Discharge Protection	A discussion of electrostatic discharge (ESD) and related recommendations and requirements for ESD protection.	page 1-5
Regulatory Information	Definitions of instrument markings. Instructions for disposing of the analyzer's lithium battery.	page 1-7

Safety Symbols

The following safety symbols are used throughout this manual. Familiarize yourself with each of the symbols and its meaning before operating this instrument.

CAUTION

Caution denotes a hazard. It calls attention to a procedure that, if not correctly performed or adhered to, could result in damage to or destruction of the instrument. Do not proceed beyond a caution note until the indicated conditions are fully understood and met.

WARNING

Warning denotes a hazard. It calls attention to a procedure which, if not correctly performed or adhered to, could result in injury or loss of life. Do not proceed beyond a warning note until the indicated conditions are fully understood and met.

General Safety Considerations

Safety Earth Ground

WARNING

This is a Safety Class I product (provided with a protective earthing ground incorporated in the power cord). The mains plug shall only be inserted in a socket outlet provided with a protective earth contact. Any interruption of the protective conductor, inside or outside of the instrument, will make the instrument dangerous. Intentional interruption is prohibited.

CAUTION

Always use the three-prong AC power cord supplied with this product. Failure to ensure adequate grounding by not using this cord may cause product damage.

Before Applying Power

WARNING

If this product is not used as specified, the protection provided by the equipment could be impaired. This product must be used in a normal condition (in which all means for protection are intact) only.

CAUTION

This product is designed for use in Installation Category II and Pollution Degree 2 per IEC 61010-1.

CAUTION

The measuring terminals on this instrument are designed to be used with external signals described in Measurement Category I, but NOT with external signals described in Categories II, III, and IV. The input of this instrument cannot be connected to the mains.

Servicing

WARNING

These servicing instructions are for use by qualified personnel only. To avoid electrical shock, do not perform any servicing unless you are qualified to do so.

WARNING

Danger of explosion if battery is incorrectly replaced. Replace only with the same or equivalent type recommended. Discard used batteries according to local ordinances and/or manufacturer's instructions.

WARNING

No operator serviceable parts inside. Refer servicing to qualified personnel. To prevent electrical shock, do not remove covers.

WARNING

For continued protection against fire hazard, replace line fuse only with same type and rating. The use of other fuses or material is prohibited.

WARNING

The detachable power cord is the instrument disconnecting device. It disconnects the mains circuits from the mains supply before other parts of the instrument. The front panel switch is only a standby switch and is not a LINE switch (disconnecting device).

Electrostatic Discharge Protection

Protection against electrostatic discharge (ESD) is essential while removing assemblies from or connecting cables to the network analyzer. Static electricity can build up on your body and can easily damage sensitive internal circuit elements when discharged. Static discharges too small to be felt can cause permanent damage. To prevent damage to the instrument:

- **always** have a grounded, conductive table mat in front of your test equipment.
- **always** wear a grounded wrist strap, connected to a grounded conductive table mat, having a 1 M Ω resistor in series with it, when handling components and assemblies or when making connections.
- **always** wear a heel strap when working in an area with a conductive floor. If you are uncertain about the conductivity of your floor, wear a heel strap.
- **always** ground yourself before you clean, inspect, or make a connection to a static-sensitive device or test port. You can, for example, grasp the grounded outer shell of the test port or cable connector briefly.
- **always** ground the center conductor of a test cable before making a connection to the analyzer test port or other static-sensitive device. This can be done as follows:
 1. Connect a short (from your calibration kit) to one end of the cable to short the center conductor to the outer conductor.
 2. While wearing a grounded wrist strap, grasp the outer shell of the cable connector.
 3. Connect the other end of the cable to the test port and remove the short from the cable.

Figure 1-1 shows a typical ESD protection setup using a grounded mat and wrist strap. Refer to **“ESD Supplies” on page 6-13** for part numbers.



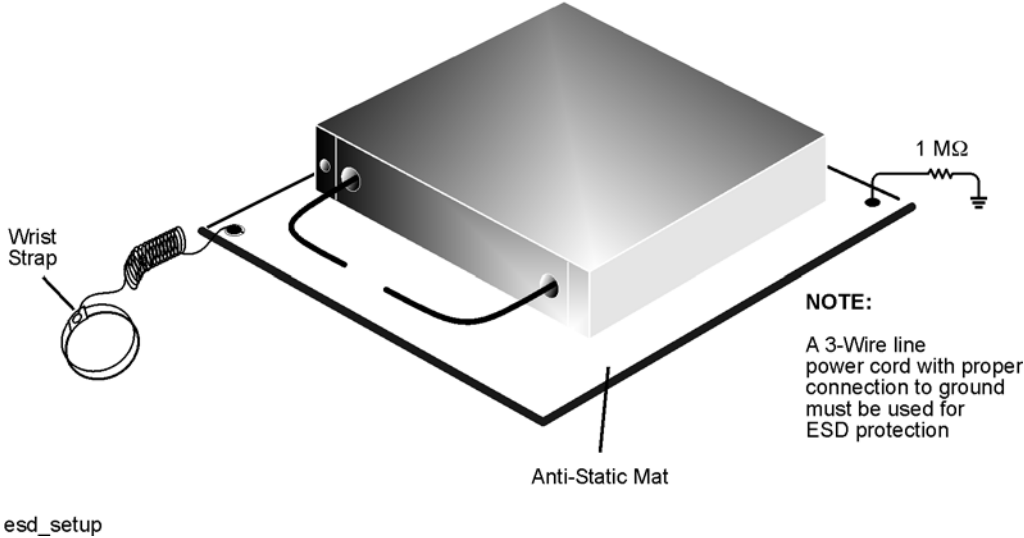







Figure 1-1 ESD Protection Setup



Regulatory Information

This section contains information that is required by various government regulatory agencies.

Instrument Markings

	<p>The instruction documentation symbol. The product is marked with this symbol when it is necessary for the user to refer to the instructions in the documentation.</p>
	<p>This symbol indicates separate collection for electrical and electronic equipment, mandated under EU law as of August 13, 2005. All electric and electronic equipment are required to be separated from normal waste for disposal (Reference WEEE Directive, 2002/96/EC).</p>
	<p>The CE mark is a registered trademark of the European Community. (If accompanied by a year, it is when the design was proven.)</p>
	<p>The CSA mark is a registered trademark of the CSA International.</p>
	<p>This mark designates the product is an Industrial Scientific and Medical Group 1 Class A product (reference CISPR 11, Clause 5).</p>
	<p>This is a marking to indicate product compliance with the Canadian Interference-Causing Equipment Standard (ICES-001).</p>
<p>IP 2 0</p>	<p>The instrument has been designed to meet the requirements of IP 2 0 for egress and operational environment.</p>
	<p>The RCM mark is a registered trademark of the Australian Communications and Media Authority.</p>
	<p>Indicates the time period during which no hazardous or toxic substance elements are expected to leak or deteriorate during normal use. Forty years is the expected useful life of the product.</p>
	<p>This symbol on all primary or secondary packaging indicates compliance to China standard GB 18455-2001.</p>
	<p>South Korean Certification (KC) mark; includes the marking's identifier code which follows the format: MSIP-REM-YYY-ZZZZZZZZZZZZZZ or KCC-REM-YYY-ZZZZZZZZZZZZ.</p>

Battery Disposal

If either the primary power battery, or the RTC (real time clock) battery (on the A3 front panel interface board) needs to be disposed of, dispose of it in accordance with your country's requirements. If required, you may return the battery to Keysight Technologies for disposal. Refer to **"Contacting Keysight" on page 2-5** for assistance.



**DO NOT THROW BATTERIES AWAY BUT
COLLECT AS SMALL CHEMICAL WASTE.**

For instructions on removing and replacing the primary power battery, refer to **"Removing and Replacing the Main Battery" on page 7-6**.

For instructions on removing and replacing the RTC (real time clock) battery located on the A3 front panel interface board, refer to **" on page 7-26**.

2 General Product Information

Information in This Chapter

Chapter Two at-a-Glance

Section Title	Summary of Content	Start Page
Maintenance	Cleaning instructions for the external surfaces of your analyzer. Information about electrical maintenance of your analyzer.	page 2-2
Analyzer Options	A list of the options available for the microwave network analyzers.	page 2-3
Keysight Support, Services, and Assistance	The Internet address (URL) for Keysight assistance. Service and support options available. Calibration options available. Important information about shipping your analyzer to Keysight for service or repair.	page 2-4

Maintenance

WARNING

To prevent electrical shock, disconnect the analyzer from the mains source before cleaning. Use a dry cloth or one slightly dampened with water to clean the external case parts. Do not attempt to clean internally.

Physical Maintenance

Clean the analyzer case using a dry or slightly damp cloth only.

Electrical Maintenance

Refer to **"Contacting Keysight" on page 2-5** and to **Chapter 3, "Tests and Adjustments."**

Analyzer Options

Below is a list of options available for the FieldFox N9912A at the time of initial product release. Additional options will be added as product features are enhanced. Go to www.keysight.com/find/fieldfox2 for information on currently available upgrade options.

Option 110, Transmission Measurement

This option allows use of the second port in either the NA (network analyzer) or CAT (cable and antenna test) modes for transmission measurements.

Option 111, QuickCal

This option provides a calibration that is performed automatically using calibration standards that are built-in to the N9912A. Calibration standards are automatically switched in as needed. QuickCal is ideal for making quick DTF and cable loss measurements without taking the time to perform a full O,S,L Cal.

Option 230, 4 GHz Spectrum Analyzer

This option allow the N9912A to make spectrum analyzer measurements from 100 kHz to 4 GHz. This option can be installed only on a 4 GHz unit.

Option 231, 6 GHz Spectrum Analyzer

This option allow the N9912A to make spectrum analyzer measurements from 100 kHz to 6 GHz. This option can be installed only on a 6 GHz unit.

Option 235, Preamplifier for Spectrum Analyzer

This option adds a preamplifier to the input port for spectrum analyzer measurements.

Option 302, External USB Power Sensor Support

This option allows the use of an external USB controllable power sensor.

Option 303, Network Analyzer Capability

This option allows the N9912A to make one-port network analyzer measurements. For two-port network analyzer measurements, add Option 110.

Keysight Support, Services, and Assistance

Information on the following topics is included in this section.

- [“Service and Support Options”](#)
- [“Calibration Options”](#)
- [“Contacting Keysight”](#)
- [“Shipping Your Analyzer to Keysight for Service or Repair”](#)

Service and Support Options

The analyzer’s standard warranty is a one-year return to Keysight Technologies service warranty.

NOTE

There are other repair and calibration options available from Keysight Technologies. Contact Keysight for additional information on available service agreements for this product. Refer to [“Contacting Keysight” on page 2-5](#).

Calibration Options

Commercial Calibration Certificate with Test Data

A complete set of measurements that test the analyzer to the manufacturer’s published specifications. It includes a calibration label, a calibration certificate, and the corresponding calibration data report. This calibration conforms to ISO 9001.

ISO 17025 Standards Compliant Calibration

A complete set of measurements that test the analyzer to the manufacturer’s published specifications. It includes a calibration label, an ISO 17025 calibration certificate, and the corresponding calibration data, measurement uncertainties, and guardbands on all customer specifications. This calibration conforms to ISO 17025 and ISO 9001.

This calibration option is available at the time of purchase or can be obtained later by sending your analyzer to Keysight for calibration. Refer to [“Shipping Your Analyzer to Keysight for Service or Repair”](#).

ANSI Z540 Standards Compliant Calibration

A complete set of measurements that test the analyzer to the manufacturer’s published specifications. It includes both pre- and post-adjustment data with measurement uncertainty information compliant to the ANSI/NCSL Z540 standard.

This calibration option is available at the time of purchase or can be obtained later by sending your analyzer to Keysight for calibration. Refer to [“Shipping Your Analyzer to Keysight for Service or Repair”](#).

Contacting Keysight

Assistance with test and measurements needs and information on finding a local Keysight office are available on the Web at:

<http://www.keysight.com/find/assist>

If you do not have access to the Internet, please contact your Keysight field engineer.

NOTE

In any correspondence or telephone conversation, refer to the Keysight product by its model number and full serial number. With this information, the Keysight representative can determine whether your product is still within its warranty period.

Shipping Your Analyzer to Keysight for Service or Repair

NOTE

Keysight Technologies reserves the right to reformat or replace the internal hard disk drive in your analyzer as part of its repair. This will erase all user information stored on the hard disk. It is imperative, therefore, that you make a backup copy of your critical test data located on the analyzer's hard disk before shipping it to Keysight for repair.

If you wish to send your network analyzer to Keysight Technologies for service or repair:

- Include a complete description of the service requested or of the failure and a description of any failed test and any error message.
- Ship the analyzer using the original or comparable antistatic packaging materials.
- Contact Keysight for instructions on where to ship your analyzer. Refer to [“Contacting Keysight” on page 2-5](#).

General Product Information
Keysight Support, Services, and Assistance

3 Tests and Adjustments

Information in This Chapter

This chapter contains procedures to help you check, verify, and adjust your N9912A analyzer.

- The checks verify the operation of the assemblies in your analyzer.
- The adjustments allow you to tune your analyzer for maximum response.

NOTE

The Keysight N7841A software package is required to test and adjust your analyzer. This software package must be purchased separately. It can be downloaded from the Internet and a license purchased on-line, or it can be ordered on a CD-ROM. Go to www.keysight.com/find/calibrationsoftware for further information. The help file for the N7841A software package is also available at this URL.

Chapter Three at-a-Glance

Section Title	Summary of Content	Start Page
Before You Begin	Items to consider or procedures to perform before testing is begun: <ul style="list-style-type: none"> – Verify the operating environment. – Protect Against Electrostatic Discharge (ESD) – Allow the Analyzer to Warm Up – Review the Principles of Connector Care 	page 3-3
Service Test Equipment	A list of additional equipment recommended for servicing the N9912A analyzer.	page 3-5
Before Returning an Instrument to a Customer	A list of things to do before returning an instrument to a customer after servicing is completed.	page 3-6
Operational Check	An operation check that should be performed before returning an instrument to a customer.	page 3-7
Performance Tests (Keysight N7841A Software Package)^a	A list of performance tests included in the Keysight N7841A software package.	page 3-8

Tests and Adjustments
Information in This Chapter

Section Title	Summary of Content	Start Page
Adjustments (Keysight N7841A Software Package)^a	A list of adjustments included in the Keysight N7841A software package.	page 3-9

-
- a. The Keysight N7841A software package must be purchased separately. Go to www.keysight.com/find/calibrationsoftware for information.

Before You Begin

Before checking, verifying, or adjusting the analyzer, refer to the following paragraphs to:

- Make sure the operating environment is within 19 to 27 °C and 5 to 95% humidity.
- Make sure that proper electrostatic discharge (ESD) protection is provided.
- Review the principles of connector care.

Protect Against Electrostatic Discharge (ESD)

This is important. If not properly protected against, electrostatic discharge can seriously damage your analyzer, resulting in costly repair.

CAUTION

To reduce the chance of electrostatic discharge, follow all of the recommendations outlined in “Electrostatic Discharge Protection” on page 1-5, for all of the procedures in this chapter.

Allow the Analyzer to Warm Up

Before testing or adjusting the N9912A analyzer, allow it to warm up as described under “DUT Warmup” in the “Getting Started” section of the N7841A help file.

Review the Principles of Connector Care

Proper connector care and connection techniques are critical for accurate and repeatable measurements. Refer to [Table 3-1](#) for tips on connector care.

Prior to making connections to your analyzer, carefully review the information about inspecting, cleaning, and gaging connectors. Refer to the calibration kit documentation for detailed connector care information.

For course numbers about additional connector care instruction, contact Keysight Technologies. Refer to [“Contacting Keysight” on page 2-5](#).

Table 3-1 Connector Care Quick Reference Guide

Handling and Storage			
Do	– Keep connectors clean	Do Not	– Touch mating-plane surfaces
	– Extend sleeve or connector nut		– Set connectors contact-end down
	– Use plastic end-caps during storage		– Store connectors or adapters loose
Visual Inspection			
Do	– Inspect all connectors carefully	Do Not	– Use a damaged connector - ever

Tests and Adjustments
Before You Begin

Table 3-1 Connector Care Quick Reference Guide

– Look for metal particles, scratches, and dents			
Connector Cleaning			
Do	– Try compressed air first	Do Not	– Use any abrasives
	– Use isopropyl alcohol ^a		• Get liquid into plastic support beads
	– Clean connector threads		
Gaging Connectors			
Do	– Clean and zero the gage before use	Do Not	– Use an out-of-specification connector
	– Use the correct gage type		
	– Use correct end of calibration block		
	– Gage all connectors before first use		
Making Connections			
Do	– Align connectors carefully	Do Not	– Apply bending force to connection
	– Make preliminary connection contact lightly		– Over tighten preliminary connection
	– Turn only the connector nut		– Twist or screw any connection
	– Use a torque wrench for final connection		– Tighten past torque wrench “break” point

a. Cleaning connectors with alcohol shall only be done with the instrument's power cord removed, and in a well-ventilated area. Allow all residual alcohol moisture to evaporate, and the fumes to dissipate prior to energizing the instrument.

Service Test Equipment

The test equipment required for the TME based N7841A test and adjustment software is listed in the N7841A help file.

The following additional test equipment is recommended when servicing the N9912A analyzer:

- Main Battery—Required if the analyzer is returned for service without a battery. Refer to [Table 6-1 on page 6-12](#) for part numbers.
- USB flash drive—Used for firmware upgrades, option installation, etc. Also known as USB memory stick. Must be 128 MB or larger.
- Small, free-standing fan—Used to cool the analyzer if internal temperature is too high. See “DUT Warmup” in the “Getting Started” section of the N7841A help file for usage instructions. Generic small office fan of approximately six inches in diameter is sufficient.
- Type-N male cal kit—Tee cal kit, part number 1250-3607, is recommended. This matches the default cal kit definition stored in the analyzer. Cal kits 85032E/F or 85054B/D may be substituted.
- Mini SD flash card—Required to re-load firmware onto the A6 SOM board. A “mini” sized Secure Digital (SD) flash memory card is between “standard” and “micro” sizes. The memory size must be at least 64 MB and not greater than 2 GB. This card is not available from Keysight. To identify a supplier, search the Web for “mini sd card”.
- Stereo headphones or ear buds—May be used to troubleshoot sound output if there is a problem with the internal speaker.

Before Returning an Instrument to a Customer

When finished servicing an N9912A analyzer, perform the following before returning the unit to the customer:

- Set the Display Colors to Indoors and the display Brightness to 80% via Service (7) > Display.
- Perform an Operational Check as described in the following section.
- Connect and disconnect the external battery charger while the N9912A is operating and confirm that the power cord icon is displayed appropriately at the top of the display.
- Charge the battery to 80% or higher.

Operational Check

1. Preset the instrument, press Preset (.) > Preset.
2. Leave the RF OUT connector open.
3. Press: Scale/Amptd > Ref Pos > 2 > Enter
4. The trace should be within +/- 5 dB of 0.00 dB.
5. Connect a known good load to the RF OUT connector.
6. The trace should be below 30 dB.
7. Press: Measure > More. If an Insertion Loss softkey is displayed, then do the following:
 - a. Press: Insertion Loss.
 - b. Connect a short cable between the RF OUT and RF IN connectors.
 - c. The trace should be within +/- 15 dB of 0.00 dB.
8. Press: Mode. If an SA softkey is displayed, then do the following:
 - a. Press: SA
 - b. Leave the RF IN connector open.
 - c. Between 30 MHz and 5 GHz, the trace should be below -45 dBm.
 - d. Between 5 GHz and 6 GHz, the trace should be below -35 dBm.

NOTE

If the operational check fails, allow the instrument to warm up for 15 minutes and try again.

Performance Tests (Keysight N7841A Software Package)

The performance tests section of the Keysight N7841A software package verifies the electrical performance of your N9912A analyzer. The software automatically configures your analyzer to execute the performance tests.

The N7841A software package is not included with the analyzer; it must be ordered separately. It can be downloaded from the Internet and a license purchased on-line, or it can be ordered on a CD-ROM. Go to www.keysight.com/find/calibrationsoftware for further information.

There are:

- Four tests for the general functionality of the analyzer.
- Seven additional tests for the SA (spectrum analyzer) functions.

Total test time will vary from 7 to 36 minutes depending upon options installed.

Details for these tests and recommended troubleshooting information can be found in the N7841A help file.

General Tests

Total test time for these tests is 8 minutes.

- Frequency Accuracy Test
- Error Terms Test (CAT Functional)—This test includes an adjustment (see [“Adjustments \(Keysight N7841A Software Package\)” on page 3-9](#)) and should be performed every 12 months.
- High/Low Output Power Output Test (CAT Functional)
- Crosstalk S21 Test (CAT Functional)

Spectrum Analyzer Specific Tests

Total test time for these tests is 29 minutes.

- Absolute Amplitude Accuracy Test
- IF Frequency Response Test (Functional)
- Frequency Response with Preamp Off Test
- Frequency Response with Preamp On Test
- Displayed Average Noise Level with Preamp On Test
- Noise Sidebands Test

Adjustments (Keysight N7841A Software Package)

The adjustments section of the Keysight N7841A software package may be used to fine-tune your analyzer.

The N7841A software package is not included with the analyzer; it must be ordered separately. It can be downloaded from the Internet and a license purchased on-line, or it can be ordered on a CD-ROM. Go to www.keysight.com/find/calibrationsoftware for further information.

These adjustments consist of:

- Three general adjustments that are used to adjust the general functions of the analyzer.
- Seven adjustments specifically for the SA (spectrum analyzer) functions.

Total adjustment time will vary from 1 to 80 minutes depending upon options installed.

If multiple adjustments are to be performed, perform them in the order listed by the N7841A software.

Details for these adjustments, and recommended troubleshooting information, can be found in the N7841A help file.

General Adjustments

Total time for these adjustments is six minutes.

- “Frequency Accuracy”
- “ADC Overload Adjustment”
- “Error Terms (NA) Adjustment”—This adjustment is part of the Error Terms Test (see [“Performance Tests \(Keysight N7841A Software Package\)” on page 3-8](#)) and should be performed every 12 months. It refreshes the definition of the preset calibration.

Spectrum Analyzer Specific Adjustments

Total time for these adjustments is 75 minutes.

- “IF Frequency Response Adjustment”
- “Absolute Amplitude Adjustment”
- “Frequency Response with Preamp On Adjustment”
- “Frequency Response with Preamp Off Adjustment”
- “Attenuator Slope Adjustment”
- “IF Offset Adjustment”
- “Spur Dodging Adjustment”

Tests and Adjustments
Adjustments (Keysight N7841A Software Package)

4 Troubleshooting

Information in This Chapter

The information in this chapter helps you:

- Identify the portion of the analyzer at fault.
- Locate the specific troubleshooting procedure to identify the assembly or peripheral at fault.

The sections in this chapter are arranged in a logical troubleshooting order. The following table lists the sections and a brief summary of what to look for in that section.

Chapter Four at-a-Glance

Section Title	Summary of Content	Start Page
Getting Started with Troubleshooting	A starting point to begin troubleshooting.	page 4-4
Power Up Troubleshooting	Power-up problems: – Power supply problems	page 4-6
Front Panel Group Troubleshooting	Problems with the front panel assemblies of the analyzer.	page 4-7
Measurement Group Troubleshooting	Problems with the measurement group assemblies of the analyzer.	page 4-8

Protect Against Electrostatic Discharge (ESD)

This is important. If not properly protected against, electrostatic discharge can seriously damage your analyzer, resulting in costly repair.

CAUTION

To reduce the chance of electrostatic discharge, follow all of the recommendations outlined in **“Electrostatic Discharge Protection”** on **page 1-5**, for all of the procedures in this chapter.

Assembly Replacement Sequence

After identifying the problem requiring an assembly to be replaced, follow these steps:

- Step 1.** Order a replacement assembly. Refer to [Chapter 6, "Replaceable Parts."](#)
- Step 2.** Replace the faulty assembly and determine what adjustments are necessary. Refer to [Chapter 7, "Repair and Replacement Procedures."](#)
- Step 3.** Perform the necessary adjustments. Refer to [Chapter 3, "Tests and Adjustments."](#)
- Step 4.** Perform the necessary performance tests. Refer to [Chapter 3, "Tests and Adjustments."](#)

Getting Started with Troubleshooting

Where you begin troubleshooting depends upon the symptoms of the failure. Start by checking the basics as outlined in the following section. Also review the flowchart in [Figure 4-1 on page 4-5](#). You should then be able to determine where in the troubleshooting procedure to begin, to locate the failed assembly.

Check the Basics

A problem can often be solved by repeating the procedure you were following when the problem occurred. Before calling Keysight Technologies or returning the instrument for service, please perform the following checks:

1. Does the analyzer have power available? It is recommended that the battery is installed and the AC power adapter is also connected.
2. Does the analyzer turn On and Off when the On/Off Button is pressed? When the unit is on, the green LED below the button should light.
3. Does the analyzer power up normally into CAT mode? If not, see ["Power Up Troubleshooting" on page 4-6](#).
4. If other equipment, cables, and connectors are being used with the analyzer, make sure they are clean, connected properly and operating correctly.
5. Review the procedure for the measurement being performed when the problem appeared. Are all the settings correct? If not, correct them.
6. If the analyzer is not functioning as expected, return it to a known state by pressing the **Preset** key.
7. If the problem is thought to be due to firmware, check to see if the instrument has the latest firmware before starting the troubleshooting procedure. Refer to ["Firmware Upgrades" in Chapter 8](#) for instructions.

Troubleshooting Organization

Follow the flowgraph in [Figure 4-1](#) to help direct you to the correct section for troubleshooting the analyzer.

Figure 4-1 Troubleshooting Organization Flowchart

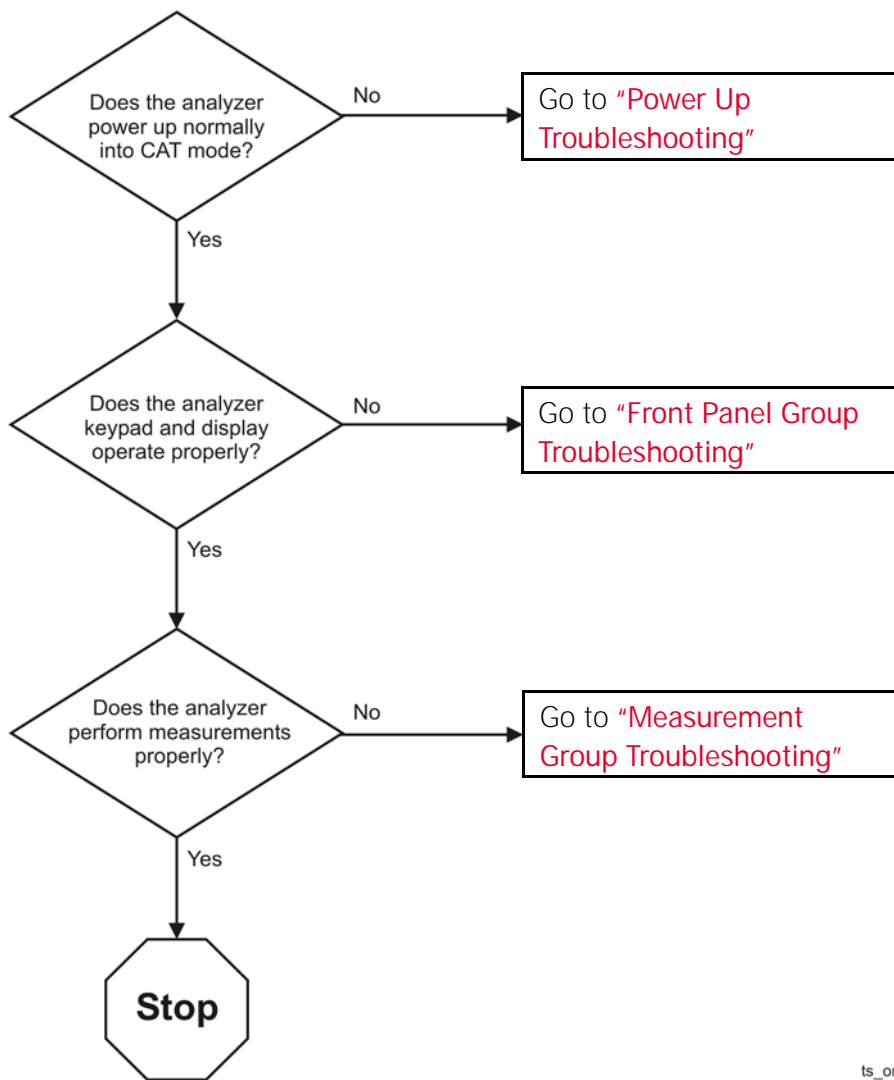

Power Up Troubleshooting

If the display is operational but the unit does not boot up successfully into CAT mode:

- Make sure there is sufficient power for the unit to operate.
- Try re-installing firmware using the firmware upgrade process described in [Chapter 8](#).
- Assume corrupted firmware on the A6 SOM board, follow the ["Install Firmware from SD Card"](#) near the end of [Chapter 7](#).

If the display is dark but the unit may have booted successfully:

- Wait for two minutes to make sure the boot process has completed, then press any front panel key.

If the boot process has completed successfully, the keypad will flash when the key is pressed.

Front Panel Group Troubleshooting

If no sound:

- Enter a value of just "." (decimal point) for a frequency.

A double beep should occur. Plug headphones into the unit if there is no sound from the internal speaker. The internal speaker is disabled when headphones are plugged in.

If the display is dark (no backlight):

- Press: Mode > System(7) > the left-most soft key > the next to the left-most soft key > press the up arrow many times.

This should bring the display brightness setting to a viewable level.

Measurement Group Troubleshooting

If calibration with the standard Type-N cal kit (1250-3607 or N9910X-800) gives unexpected results:

- Make sure the unit is warmed up for at least 30 minutes.
- Make sure the correct cal kit definition is being used; erase user data to force use of factory cal kit definitions (see [Chapter 8](#) for information on the **“Erase User Data Utility”**).

If there appears to be LAN communication problems:

- Use only 100 Base T LAN connections. Sometimes there are problems with the slower speed 10 Base T connections.

If “ADC Overload” error messages are displayed during S21 or insertion loss measurements:

- Perform the “ADC Overload Adjustment” under **“Adjustments (Keysight N7841A Software Package)”** in [Chapter 3](#).

5 Theory of Operation

Information in This Chapter

This chapter provides a general description of the operating theory of the N9912A analyzer.

- Theory of operation is explained to the assembly level only.
- Component-level circuit theory is not provided.
- Simplified block diagrams are included for each functional group.

Chapter Five at-a-Glance

Section Title	Summary of Content	Start Page
Analyzer System Operation	A summary of the theory of operation for the analyzer. A summary of the operation of the major functional groups of the analyzer.	page 5-2
Front Panel Group	Operation of the assemblies associated with the front panel group of assemblies.	page 5-4
Measurement Group	Operation of the assemblies associated with the measurement group of assemblies.	page 5-6
Operation in Modes	Description of the different operating modes and what hardware is used in each mode.	page 5-20
Temperature Related Information	Information about temperature sensors and how the analyzer responds to temperature information gathered.	page 5-26
User Calibration in CAT and NA Modes on page 5-27	Descriptions of one port and two port calibrations for the CAT and NA modes of operation.	page 5-27
Firmware Related Information	Information about firmware and firmware upgrades.	page 5-29

Analyzer System Operation

The N9912A RF analyzer operates as both a network analyzer (NA) and a spectrum analyzer (SA). The NA functions support the CAT mode.

- The NA function supports one port measurements using the RF OUT port and two port measurements using both the RF IN and RF OUT ports.
- The SA function supports measurements using the RF IN port.

See **Figure 5-1** for a simplified block diagram of the overall RF analyzer system.

All N9912A RF analyzers have the same hardware. Options to increase functionality are enabled via licenses, additional hardware is not required.

Functional Groups of the Analyzer

The operation of the analyzer can be separated into two major functional groups. Each group consists of assemblies that perform distinct functions. Some of the assemblies are related to more than one group, and both groups, to some extent, are interrelated and affect each other's performance.

The major functional groups are:

- **Front Panel Group**
- **Measurement Group**

Front Panel Group

The front panel group consists of the following:

- **A2 LCD Assembly**
- **A3 Front Panel Interface Board**

Measurement Group

The measurement group consists of the following:

- **A4 RF Board**
- **A5 System Board**
- **A6 SOM Board**
- **Main Battery**

Figure 5-1 Overall Block Diagram

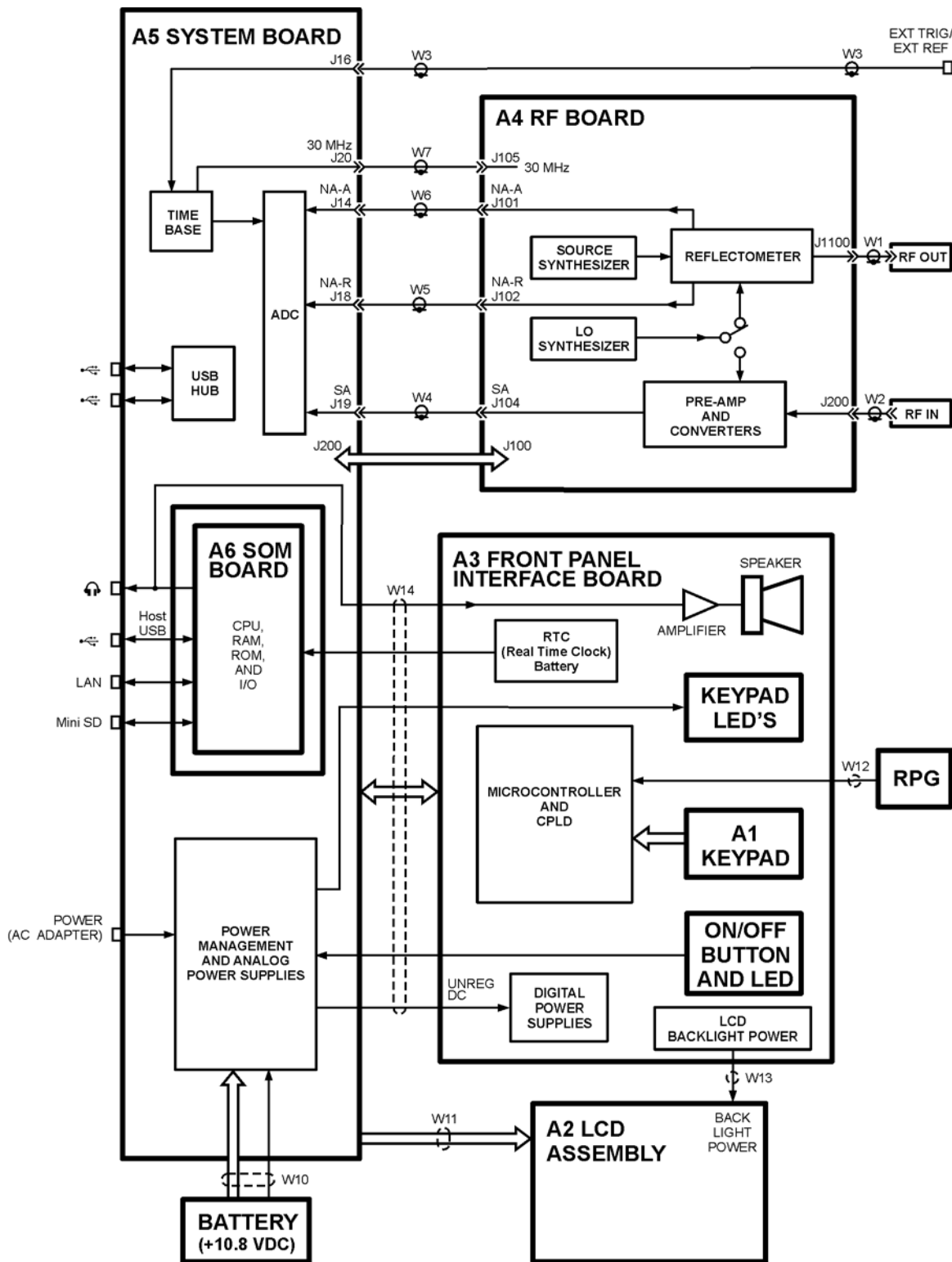

n9912a_overall_blk
24 August 2009

Front Panel Group

The front panel group consists of the following assemblies:

- **A3 Front Panel Interface Board**
- **A2 LCD Assembly**

Refer to **Figure 5-1** for a simplified overall block diagram which includes the front panel group.

A3 Front Panel Interface Board

The main function of the A3 front panel interface board is to support the user interface but it also contains the digital power supplies.

Microcontroller and CPLD

The Microcontroller and CPLD sense the keypad keys and the RPG (rotary pulse generator) knob on the front panel. The Microcontroller communicates with the A5 system board via a USB interface.

There is no separate ID EPROM on the A3 front panel interface board. All ID information is stored in the Microcontroller.

Front Panel LED's and ON/OFF Button

The power for the Keypad LED's generated on the A3 front panel interface board is derived from the +5 V digital supply. The Keypad LED's are turned on for a few seconds following each key press. This function is controlled by the firmware on the A6 SOM board.

The On/Off LED is controlled by a signal from the A5 system board. The connections for the On/Off Button and LED are direct to the A5 system board.

Real Time Clock Battery

The battery for the RTC (real time clock) on the A6 SOM board is located on the A3 front panel interface board and is connected to the A6 SOM board via the A5 system board.

Backlight Power

Power for the backlight on the A2 LCD assembly is generated on the A3 front panel interface board. Digital 5 volts is converted to approximately 25 volts. The actual voltage determines the brightness of the backlight. Two control lines from the A5 system board control on/off and intensity functions. These control lines are driven by the system monitor microcontroller on the A5 system board.

Speaker and Headphones

The speaker is located on the A3 front panel interface board. Left and right audio signals from the A6 SOM board go to the headphone jack on the A5 system board. These signals are then combined (on the A5 system board) to create a single mono signal for the speaker. An amplifier on the A3 front panel interface board drives the speaker. Plugging in the headphones disables the speaker output.

Digital Power Supplies

Digital power supplies on the A3 front panel interface board are driven by the Unreg DC voltage from the A5 system board.

The 5 volts produced is used on the A3 front panel interface board and the A5 system board.

The 3.5 volts produced is used on the A3 front panel interface board, the A5 system board, and the A6 SOM board.

Both supplies are either on or off together except for power supply sequencing and are controlled by the System Monitor Microcontroller on the A5 system board.

A2 LCD Assembly

The A2 LCD assembly contains a 6.5-inch, 640 x 480 TFT color LCD with associated drive circuitry and backlight inverter.

The LCD backlight is created by LED's connected in parallel stacks. Backlight brightness is a function of the backlight power that ranges from 22 to 27 volts. Refer to **"Backlight Power"** on page 5-4 for more information.

The backlight LED's are arranged along the top and bottom edges of the display. There are three stacks on each edge.

Measurement Group

The measurement group produces a stable output signal by phase locking a synthesized voltage-controlled oscillator (VCO).

The measurement group consists of the:

- **A4 RF Board**
- **A5 System Board**
- **A6 SOM Board**
- **Main Battery**

A simplified RF block diagram is provided in [Figure 5-2](#).

A simplified system block diagram is provided in [Figure 5-3](#).

A4 RF Board

The basic function of the A4 RF board is to provide a signal source and receivers for the analyzer functions.

There are three sections to the A4 RF board:

- the Common RF section,
- the CAT/NA RF section, and the
- SA RF section.

Common RF Section

This section is common to both NA and SA functions. In this common section, an LO synthesizer produces a single LO signal from the 30 MHz time base located on the A5 system board. The LO output is switched between the NA mixers and the SA first converter depending on the function being used. At any instant in time, either the NA receivers or the SA receiver may be active, but not both at the same time.

The LO frequency bands are listed below:

1	100 kHz to 1.6 MHz
2	1.6 MHz to 25 MHz
3	25 MHz to 0.2 GHz
4	0.2 GHz to 0.8 GHz
5	0.8 GHz to 1.6 GHz
6	1.6 GHz to 3.2 GHz
7	3.2 GHz to 3.4 GHz
8	3.4 GHz to 4.15 GHz
9	4.15 GHz to 5.1 GHz
10	5.1 GHz to 6.2 GHz

Figure 5-2 Simplified RF Block Diagram

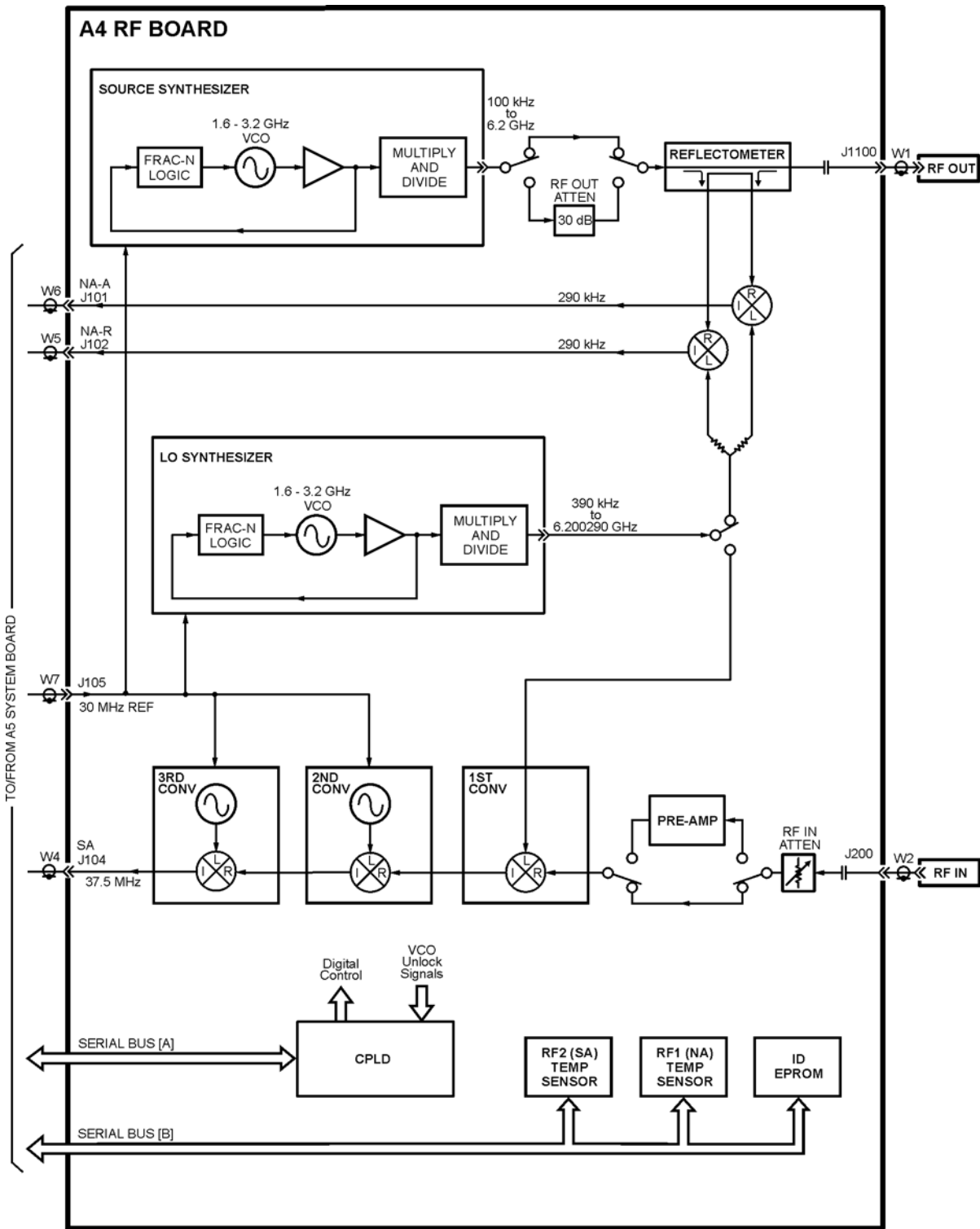

n9912a_rf_blk
24 August 2009

CAT/NA RF Section

In this section, the 30 MHz time base from the A5 system board is used to generate a source signal in the source synthesizer that covers the frequency range of 100 kHz to 6.2 GHz.

The source signal is generally rich in harmonic content. This is acceptable because the signal is used with tuned receivers.

The source frequency bands are listed below:

1	100 kHz to 1.6 MHz
2	1.6 MHz to 25 MHz
3	25 MHz to 0.2 GHz
4	0.2 GHz to 0.8 GHz
5	0.8 GHz to 1.6 GHz
6	1.6 GHz to 3.2 GHz
7	3.2 GHz to 6.2 GHz

The RF Out attenuator between the source and the reflectometer has two settings: nominal values of 0 dB and 30 dB. The setting is determined by the Hi/Lo power setting on the user interface.

The reflectometer performs three functions:

- It passes the source output signal to the RF OUT port.
- It samples the source output to the RF OUT port.
- It samples the incoming signal at the RF OUT port.

The sampled signals are mixed with the LO signal to produce two 290 kHz IF signals, NA-A and NA-R.

The reflectometer dissipates up to 1.5 watts when active.

The RF OUT port has a DC isolation capacitor (0.056uF).

SA RF Section

In this section, the signal at the RF IN port is first routed through a DC isolation capacitor (0.056 uF) then through the RF In attenuator.

RF In Attenuator

The RF In attenuator covers the range of 0 dB to 31 dB in one dB steps. An adjustment determines compensation for each of the 32 steps over 11 frequency bands (see **“SA Frequency Bands” on page 5-9**). This compensation provides nominal 1.0 dB steps.

Pre-Amp

The pre-amp that follows the RF In attenuator may be in or out during the SA mode. Option 235 is required for the firmware to enable use of this pre-amp. The pre-amp is always bypassed in CAT and NA modes.

Typical gain of the pre-amp is 22 dB. It has two sections, high-band and low-band. The low-band section covers up to 2.7 GHz.

Converters

Three stages of conversion produce the 37.5 MHz SA IF signal that goes to the A5 system board.

The first converter stage mixes the incoming signal with the LO output. Input signals below 2.7 GHz are up converted and input signals above 2.7 GHz are downconverted.

Spur avoidance is accomplished by slightly shifting the output frequency of the first converter stage. When the output frequency of the first converter is shifted, the second converter compensates for the shift.

The third converter output frequency is fixed at all times.

SA Frequency Bands

The frequency bands for the SA function are as listed below:

Up to 2.7 GHz (bands 1-4) are considered LOW bands and above 2.7 GHz (bands 5-11) are considered HIGH bands. Different hardware is used for each type.

Band	Analyzer Start Frequency (MHz)	Analyzer Stop Frequency (MHz)
1	0.000	10.000
2	30.000	715.000
3	715.000	1665.000
4	1665.000	2700.000
5	2700.000	3313.500
6	3313.500	3500.000
7	3500.000	4263.500
8	4263.500	4300.000
9	4300.000	5200.000
10	5200.000	5936.500
11	5936.500	6000.000

Power Management Circuitry

The circuitry on the A4 RF board has five special sections that may be powered down for the purpose of power management. These sections may be selectively powered down (via “load switching”) when not required for the current operating mode of the analyzer.

The sections that may be selectively powered down are:

- Source—most of the source synthesizer circuitry
- LO—most of the LO synthesizer circuitry
- SA—most of the first, second, and third converter circuitry
- Reflectometer—put into a low power state
- High-Band Pre-amp—high band section of the pre-amp turned off

The load switching for the Source, LO, and SA sections is accomplished on the A5 system board via the Analog Power Supply Load Switching circuitry.

The load switching for the Reflectometer and High-Band Preamp is accomplished on the A4 RF board.

Other Circuitry

The CPLD (Complex Programmable Logic Device) communicates with the FPGA on the A5 system board via Serial Bus [A]. It provides the digital control for the functions on the A4 RF board. It also reads the VCO unlock signals.

Serial Bus [B] allows the System Monitor on the A5 system board to read two temperature sensors and the ID EPROM for the A4 RF board.

RF1 temperature sensor (NA Temp Sensor) is near the RF OUT connector on the side of the A4 RF board that is away from the A5 system board. This temperature sensor is nearest the NA circuitry.

RF2 temperature sensor (SA Temp Sensor) is located through the A4 RF board from FL1202 on the A5 system board side of the A4 RF board. This temperature sensor is nearest the SA circuitry.

A5 System Board

The A5 system board controls all of the functions of the analyzer and digitizes the RF IF signal from the A4 RF board.

The A6 SOM (System on Module) board is mounted directly on the A5 system board.

All external connections for the analyzer come through the A5 system board except for the RF IN and RF OUT ports.

The A5 system board also controls the power switching and power management.

The instrument model number and serial number are stored on the A5 system board.

System Monitor (SM) Microcontroller

This is the heart of the analyzer. It is active whenever there is DC power available. The microcontroller has ultra-low power dissipation. It is sometimes referred to as the "MSP 430".

The following is a list of some of the functions performed by the SM.

- It monitors the On/Off button on the front panel and responds appropriately.
- It controls the on/off functions of the various power supplies in the analyzer.
- It drives the On/Off button LED.
- It reads battery pack information via the Smart Batt Bus.
- It communicates with the battery charger IC via the Smart Batt Bus.
- It interfaces to the Battery Charger and Manager circuit.
- It interfaces to the Serial Bus [B] for communication with the temperature sensors and ID EPROM's on the printed circuit boards.
- It communicates to the A6 SOM board CPU via a serial port, UART.
- It stores the instrument model number and serial number.

Battery Charger and Manager

This circuitry controls charging of the battery based on a battery charger IC. This IC is powered by a digital output on the System Monitor. The System Monitor has the capability to reset the IC, if required, by recycling the power to the IC.

This circuitry also controls the source of the Unreg DC: Batt or Ext DC. It reads the battery pack information via the Smart Batt Bus. Batt Neg is connected to the A5 ground plane.

There is an input inrush current control circuit on the Ext DC input that limits inrush current to 4 amps.

Analog Power Supplies and Load Switching

Seven different analog supply voltages are generated from the Unreg DC. All of these are used on the A4 RF board and some are used on the A5 system board.

Some sections of the circuitry on the A4 RF board may be switched to low power modes to conserve power and minimize heat. This is accomplished through load switching. See **"Power Management Circuitry" on page 5-10** for more information.

The System Monitor controls the on/off functions of the analog power supplies. All are on or off together except for power sequencing.

This circuitry also monitors the Ext DC input and, if below 10.8 volts or above 21 volts, it disconnects this input from the Unreg DC.

There are two DC power supply lines: (1) Ext DC, and (2) Batt +. Each has a 5 amp fuse immediately after the connector on the printed circuit board.

FPGA

This FPGA:

- provides the interface between the A6 SOM board and the ADC,
- provides miscellaneous interfaces for circuitry on the A4 RF board, and
- communicates with the CPU via the USB interface.

Time Base

The Time Base is an internal TCXO that produces 30 MHz signals for use throughout the analyzer.

A 10 MHz signal at the EXT TRIG/EXT REF input may be used to provide an external time base. The external time base function is controlled via the user interface. Refer to the “External Frequency Reference” section of the FieldFox User’s Guide for additional information.

There is no external trigger (EXT TRIG) function at the time of this printing.

Filters, MUX, and ADC’s

The three Filters filter the IF signals in preparation for the ADC. Filter characteristics are fixed (not programmable).

The ADC’s digitize each of the IF signals received from the A4 RF board. The input to one of the ADC’s is multiplexed between the NA-A and SA input signals. Since the NA-R and NA-A signals are sampled simultaneously, phase relationship is preserved.

The 14-bit ADC’s sample at a rate of 30 mega samples per second.

Each ADC may be put into a low power mode when not active.

Temperature Sensors

The SB1 Temp Sensor is located on the A4 RF board side of the A5 system board near the headphone jack (J3).

The SB2 Temp Sensor is on the A4 RF board side of the A5 system board near the edge of the board against the battery compartment. This temperature sensor is not under a shield.

Audio Output Jack

When headphones are plugged into the audio output jack, the internal speaker is disabled.

LAN Connector

The LAN connector supports the LAN interface on the A6 SOM board. See [“LAN Interface” on page 5-31](#) for more details.

SOM Connector

Refer to [“A6 SOM Board” on page 5-15](#) for information on SOM (System on Module) functions.

Figure 5-3 Simplified RF Block Diagram

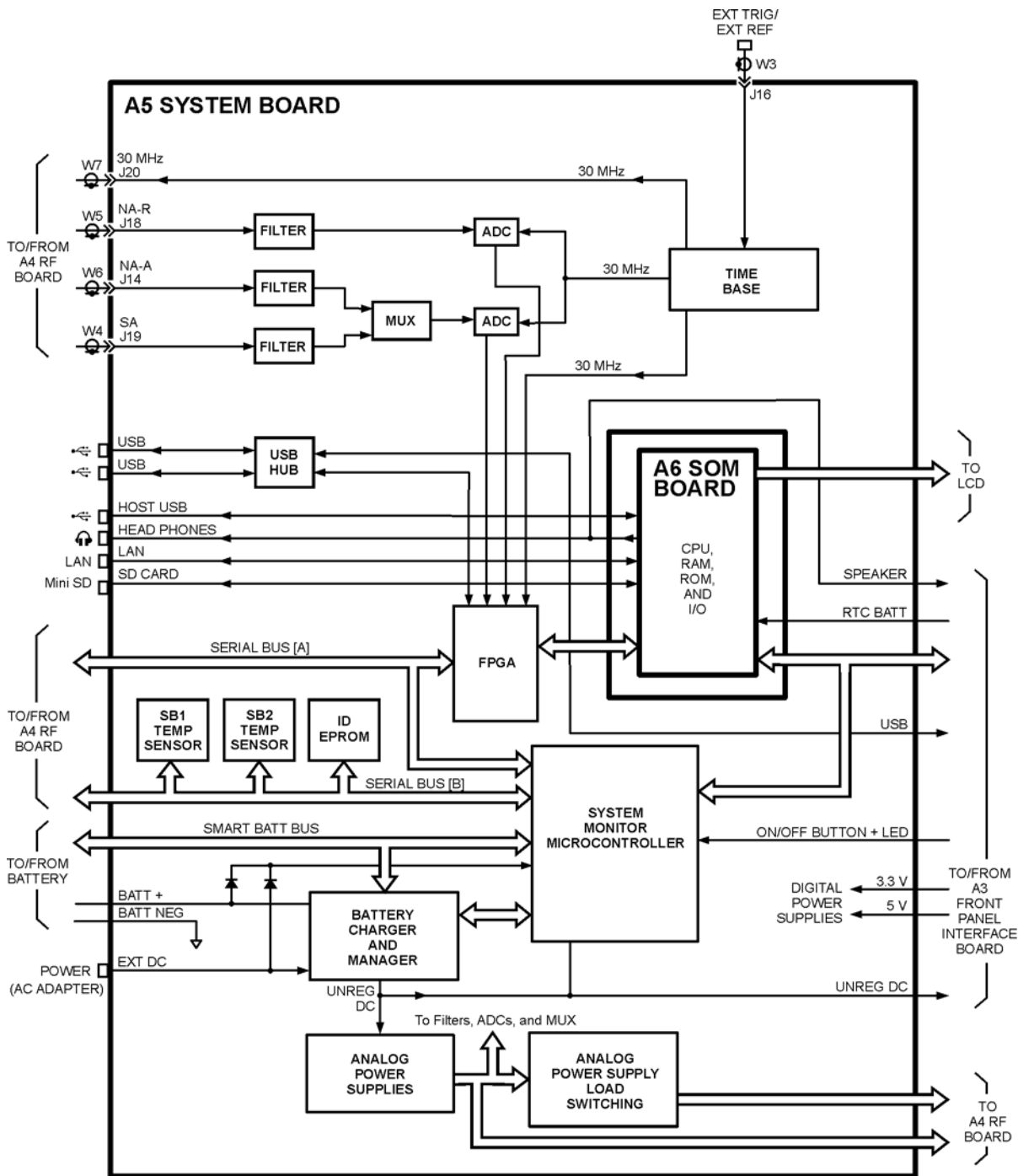

n9912a_system_blk
24 August 2009

A6 SOM Board

The A6 SOM (System on Module) board plugs directly into the A5 system board as a daughter board and contains:

- the CPU,
- 64 MB of flash ROM,
- 128 MB of RAM, and
- I/O interface.

The interfaces on the SOM are:

- UART to the System Monitor on the A5 system board
- LCD interface
- Left and right audio outputs
- SD card bus
- USB host interface
- Interface to USB hub
- LAN interface 10/100 base T
- General purpose interface lines

The A6 SOM board is powered by the 3.3 volt digital supply.

Licenses which enable instrument options are stored in the A6 SOM flash ROM.

Main Battery

The battery is a rechargeable 10.8 V lithium-ion type. Refer to **“Battery Disposal” on page 1-8** for important information about replacing and disposing of this battery.

Refer to **“Battery Related Information” on page 5-18** for details on the main battery.

Grounding and Power

Grounding

Each printed circuit board has a single ground plane. The ground planes on the A4 RF board and A5 system board are connected via the common shields at multiple points. The ground plane on the A3 front panel interface board is connected to the ground plane on the A5 system board.

There are no separate grounds in the analyzer. There is no “star” ground point in the analyzer.

Batt Neg and Ext DC neg are connected to the A5 system board ground plane.

The A2 LCD assembly has two separate grounding circuits: the LCD power and control circuits and the backlight LED's.

- The LCD power and control circuits share a ground that is connected to the ground plane on the A5 system board.
- The ground for the backlight LED's is connected to the ground plane on the A3 front panel interface board.

Voltages and Power Supplies

The following power supplies exist within the analyzer:

- Digital 5 volts—generated from Unreg DC on the A3 front panel interface board, controlled by the System Monitor on the A5 system board, and used on the A3, A4, and A5 boards.
- Digital 3.3 volts—generated from Unreg DC on the A3 front panel interface board, on/off functions controlled by the System Monitor on the A5 system board, and used on the A2 LCD assembly and A3, A4, A5, and A6 boards.
- Analog supply voltages—seven separate voltages generated from Unreg DC on the A5 system board, on/off functions controlled by the System Monitor on the A5 system board.
- LCD backlight voltage—generated on the A3 front panel interface board from the digital 5 volt supply voltage.
- Power for the System Monitor circuit—3.3 volt circuit powered from Ext DC or Batt +, whichever is greater. Used on A5 system board only.
- Unreg DC—from Ext DC or Batt +, 21 volts max.
- Ext DC—from external Power AC Adapter, nominal 15 volts, acceptable up to 19 volts.
- Batt + —from main battery, nominal 12 volts.

All voltages except Ext DC, Batt +, and the System Monitor power can be turned on/off within the analyzer. Refer to **“Power Management Circuitry” on page 5-10** for more information.

Power Control and Management

Power States

The On/Off Button is used to switch between On, Off, and Standby power states:

Off

Only the System Monitor and battery control circuits are powered up (if power is available from the battery or external power).

If the battery is charging, the LED below the On/Off Button slowly flashes orange with increasing intensity, otherwise this LED is off.

Some battery power is required in the "Off" state. A fully charged battery will discharge completely in four to six weeks when left in the analyzer.

On

This is normal operation. The On/Off Button LED is steadily lit green.

Standby

Only the digital power supplies are on. The CPU is in a low power state, maintaining RAM content. The On/Off Button LED flashes yellow briefly every two seconds.

During normal operation, unexpectedly disconnecting power to the analyzer (such as removing the main battery when the analyzer is not connected to external power) should not cause any problems. Simply re-apply power. No firmware problems are expected. Of course, this does not apply during a firmware upgrade.

Smart Power Management

The analyzer uses extensive "load switching" to minimize power dissipation. This is termed Smart Power Management (SPM). There are two motivations for power management:

- to extend battery run time
- to prevent overheating.

Sections of the circuitry are selectively powered down via "load switching", depending on the operating mode of the analyzer. Five different sections of the circuitry on the A4 RF board may be controlled via "load switching". These sections are as follows:

- Source—switched off during SA mode, switched off between sweeps during CAT or NA modes.
- LO—switched off when data is not being taken by receivers.
- SA—switched off when in one port CAT or NA modes, on all the time in two port mode.

- Reflectometer—switched to low power through state when RF OUT port receivers are inactive.
- High-Band Pre-amp—switched off when not required.

On the A5 system board, each of the ADC's may be individually switched to a low power mode when not active.

Load switching is generally transparent to the user. One obvious exception is the that the source turns off during "retrace" in the CAT and NA modes.

Battery Related Information

Battery Description and Operation

The main battery is an SBS (Smart Battery System) compliant pack of lithium ion cells.

Refer to **"Battery Disposal" on page 1-8** for important information about replacing and disposing of this battery.

The nominal voltage of the battery is 10.8 volts and normally varies from 9 to 12 volts.

The battery has built-in sensors, a processor, and control circuitry. This is referred to as the Smart Battery circuitry.

The Smart Battery circuitry communicates battery condition and history information digitally via a digital Smart Batt Bus. The Smart Battery circuitry is read-only.

Both the battery charging circuit and the System Monitor read battery information over the Smart Batt Bus.

The battery temperature reported by the analyzer is based on a sensor inside the battery. Temperature information is available over the Smart Batt Bus. The thermistor connection (T) on the battery is not used.

The Smart Battery circuit may shut down the battery when the temperature is out of the acceptable range or when the battery charge is too low.

See the "Working with the Lithium-Ion Battery" section of the FieldFox User's Guide for additional information on:

- built in charge level gauge
- the battery information screen
- battery care

Battery Information Screen

Refer to the FieldFox User's Guide for information on how to access this screen.

Most of the items displayed on the screen come directly from the battery via the Smart Batt Bus. Only the first three items are influenced by the analyzer.

Battery Charging Management

The battery pack determines when the battery needs charging and requests a charge over the Smart Batt Bus.

The Battery Charger and Manager circuit on the A5 system board responds by charging the battery if there is sufficient voltage on the Ext DC line. A minimum of approximately 15 volts is required to charge the battery.

The System Monitor on the A5 system board monitors the battery's temperature and, if too high or too low, disables charging of the battery.

How to tell if the battery is charging:

- If the analyzer is On, the lightning bolt is displayed in the battery icon.
- If the analyzer is Off, the LED below the On/Off Button slowly flashes orange with increasing intensity.
- If the analyzer is in Standby, turn the analyzer on and observe the battery icon.

The battery charges much faster up to 70% of its full charge than it does above 70% of full charge.

Battery Life

When a battery is new, an instrument should operate for about four hours on a fully charged battery. The actual time will depend on operating mode and temperature.

As a battery goes through charge/discharge cycles, its capacity will decrease. A typical battery will have more than 70% of its initial capacity after 200 full discharge cycles when operating at 20 to 30 °C ambient temperature.

Operation in Modes

The FieldFox User's Guide describes the various modes of operation and describes the user interface for each mode. The following information describes how the hardware is used in the various modes to make measurements.

There are four basic modes of operation:

- CAT—Cable and Antenna Test
- NA—Network Analyzer
- SA—Spectrum Analyzer
- PM—Power Meter

CAT and NA modes have similar capabilities but are separate modes of operation.

Additional modes of operation may be created as new firmware is developed. The four basic modes listed above represent how the hardware may be used to make basic measurements. Additional modes will provide customized user interfaces but will not change how the basic measurements are performed.

The following table indicates port functionality for each mode of operation and the required options. See the **"Service Related User Operations"** section of **Chapter 8** for more details.

Table 5-1 Port Function by Mode

Measurement Mode	RF OUT Port	RF IN Port	Required Option(s)
CAT (One Port)	Input/Output	Inactive	None (standard)
CAT Insertion Loss	Output	Input	110
NA S11	Input/Output	Inactive	303
NA S21	Output	Input	110 and 303
SA	Inactive	Input	230 or 231
Power Meter	Inactive	Inactive	302

For a given mode, the analyzer "remembers" the most recent state of the current mode when you change to another mode.

For most screens under System 7 key, the current measurement mode continues to operate while the screen is displayed. For instance, while the battery information screen is displayed, the measurement mode remains active.

There are two exceptions to this:

- the “Options (Licensing)” screen
- “Error Log” screen

When either of these screens is displayed, the firmware is in a special monitor mode and measurements are suspended.

CAT and NA Modes

CAT and NA modes have some similar capabilities but are still separate operating modes.

Measurement similarities:

- Return Loss = S11 magnitude
- Insertion Loss = S21 magnitude

Unlike S11 and S21, the values displayed below zero for Return Loss and Insertion Loss are not negative.

Measurements are done at an effective IFBW (IF bandwidth) of 30 kHz except when max for Interference Rejection measurements when it is at a 300 Hz effective IFBW.

There is no user control of the output power level of the source synthesizer on the A4 RF board.

The only user control of output power level is the high/low setting on the RF Out Atten, 30 dB in or out.

Details About One Port Measurements

Refer to the block diagram below showing the signal paths highlighted in color.

Figure 5-4 Signal Paths for One Port CAT/NA Measurements

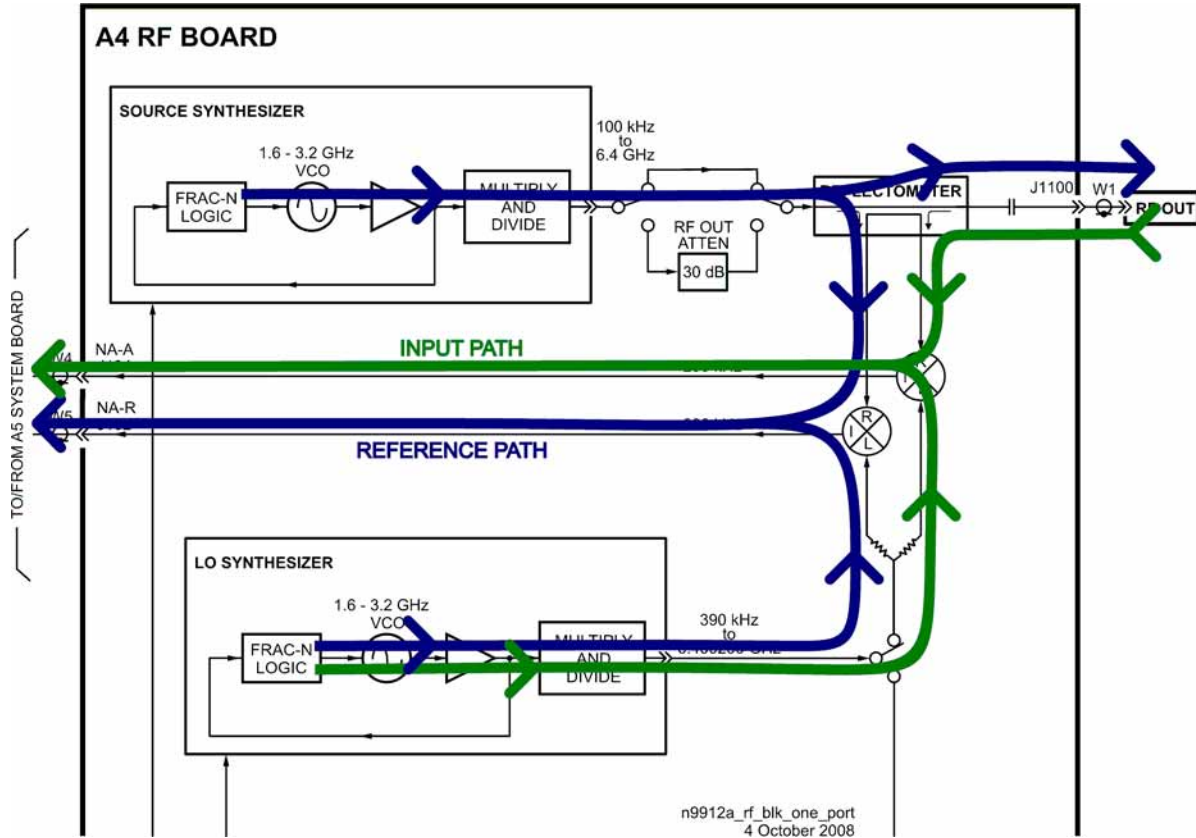

The source and receiver step through each frequency point in the sweep.

Single sweep measures both NA-A and NA-R signals. Because two ADC's are used simultaneously, phase relationship is preserved. (Phase information is available to the user only in NA mode.)

Details About Two Port Measurements

Refer to the block diagram below showing the signal paths highlighted in color.

Figure 5-5 Signal Paths for Two Port CAT/NA Measurements

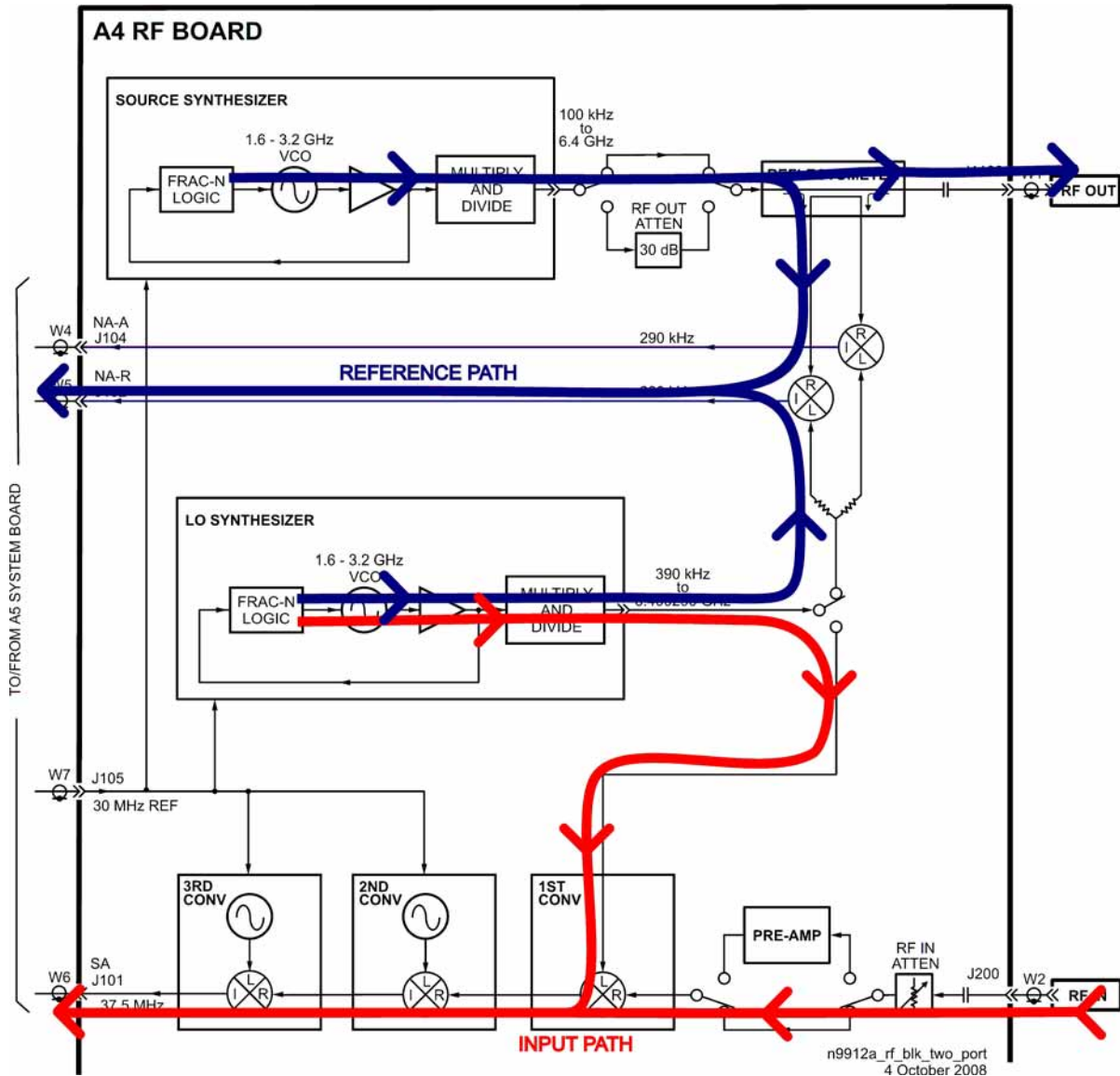

The RF IN port is used as the second port.

Two sweeps are required for a measurement: one sweep for the NA-R signal and a second sweep for the SA signal. Because of the shared LO and A/D, no phase relationship is available, only magnitude.

When measuring the SA signal, the source and SA receiver step through each frequency point in the sweep. (The SA receiver is effectively in step mode and tuned to the source frequency.)

The SA Pre-amp is always switched out.

The RF In Atten is not under user control. For a given frequency, the ADC Overload Adjustment determines the setting for this attenuator to prevent over-range warnings.

There is no default calibration for two port measurements. Uncalibrated (not normalized) measurement of a short thru cable typically shows a trace with some sawtooth characteristics.

SA adjustment results are ignored when in CAT/NA mode. The "raw" unadjusted readings are used. There is one exception: the results of the IF Offset Adjustment are used during CAT/NA modes.

SA Mode

The signal path for SA mode is the same as the input path for two port CAT/NA modes.

The RF In Atten can be set to 32 different levels: nominal 0 through 31 dB in 1 dB steps. The Attenuator Slope Adjustment determines the correction factors for each step in each frequency band.

The RF In Atten can be controlled manually or automatically. When in auto mode, the Reference Level setting determines the attenuator setting.

The Pre-amp can be in or out. Nominal gain of the pre-amp is 22 dB.

The "Attn" and "PA" indicators in the display header give current status. The Scale/Amptd hard key provides access to control for them.

The displayed measured value for a given signal is automatically compensated for in the current Attn and PA settings. For instance, if an incoming signal is measured at -70 dBm with the RF IN Atten set to 5 dB and PA "out", changing to PA "in" will give a measured value of approximately -70 (+/- because the 22 dB for the PA is only nominal). The difference seen in the trace will be that the noise floor of the trace will be lowered by approximately 22 dB. If the RF In Atten is changed from 5 dB to 15 dB, the measured value will not change significantly (still approximately -70 dBm) but the noise floor will raise by 10 dB.

SA has two basic modes: step and FFT.

Step mode reads a narrow slice of the spectrum and the LO steps for each slice. In this mode, a trace on the display is composed from multiple slices. Generally spans greater than 100 kHz operate in step mode.

FFT mode reads a wide slice of the spectrum and the LO is fixed. In this mode, a trace on the display is based on a single LO setting.

The LO minimum step size is 2 MHz; this restriction limits spurs.

The hardware operation of the A/D's is essentially the same for both step and FFT modes. The difference is the digital signal processing.

The SA adjustments generally correct the gain with 11 frequency bands. See **"SA Frequency Bands" on page 5-9** for a listing of the 11 bands. See the TME help file for details on SA adjustments.

Power Meter Mode

All measurement circuitry is switched to the low power state during PM (power meter) mode. This is the mode with the lowest power dissipation.

The analyzer has no power output capability in this mode. The analyzer essentially functions as a display for a USB power sensor.

Temperature Related Information

Five temperature sensors are in the analyzer: two on the A4 RF board, two on the A5 system board, and one in the battery pack.

- RF1—NA Temp Sensor (on the A4 RF board near the NA circuitry)
- RF2—SA Temp Sensor (on the A4 RF board near the SA circuitry)
- SB1—on the A5 system board near the headphone jack
- SB2—on the A5 system board near the battery compartment
- Battery pack—inside the battery pack

The battery pack has its own internal temperature sensor. The battery pack will shut itself down in the case of extreme temperatures.

See [Chapter 8](#) for instructions on viewing temperature readings.

See the FieldFox User's Guide, "FieldFox High-Temperature Protection" section, for information about operation at high temperature.

The temperature readings for sensor RF2 are stored as part of the adjustment data for the Frequency Response Preamp On/Off adjustments.

During normal operation, as each SA measurement is taken, the current RF2 temperature reading is compared to the temperature stored for the Frequency Response adjustment. A delta temperature is calculated. Each SA measurement is adjusted to compensated for the delta temperature.

The internal temperature of the unit is critical when executing the TME based software for tests and adjustments. See the TME help for detailed information.

Under typical bench top (indoor) conditions, the internal temperature of the unit will be about 20 °C above ambient once the internal temperature has stabilized. It will typically take 60 to 90 minutes for the internal temperature to stabilize when a "cold" unit is turned on.

User Calibration in CAT and NA Modes

There are two types of calibrations for the CAT and NA modes: one port and two port. See the FieldFox User's Guide "Calibration for CAT and NA Modes" section for specific instructions for performing these calibrations. A calibration performed in CAT mode will be applied in NA mode and vice versa.

When a user calibration is performed, the full frequency range of the analyzer is calibrated even though the current state of the analyzer may be less than the full range. This allows a calibration to be "interpolated" beyond the frequencies set at the time of calibration (an asterisk "*" on the display indicates interpolation).

When choosing the "Connector Type", choose the characteristics that correspond to the cal kit you will use. For the standard FieldFox Tee cal kit, part number 1250-3607, choose "Type-N-M-".

Do not leave cal standards connected to the RF IN or RF OUT ports for more than three minutes. Heat in the port connectors may affect the accuracy of the standards.

Table 5-2 Cal Status Indicators

Indicator	Meaning	Additional Indicators
Cal ON	Preset (factory) calibration is active	* = interpolation active ? = Measurement conditions have changed.
Cal ON Q	QuickCal calibration is active	* = interpolation active ? = Measurement conditions have changed.
Cal ON U	O, S, L calibration is active	* = interpolation active ? = Measurement conditions have changed.
Cal OFF	Calibration is inactive	
Cal OFF*	No calibration available to activate for this measurement.	

One Port Calibration

One port calibration applies only to 1-port measurements in CAT and NA modes. When the analyzer is adjusted at the factory or during annual calibration, a preset calibration is stored in the analyzer.

The preset calibration covers the full frequency range of the analyzer. The preset calibration is active whenever "Cal ON" is displayed on the left side of the screen. Presetting the analyzer activates the preset calibration.

The preset calibration provides very good measurement performance at the RF OUT connector when the analyzer has thermally stabilized to room temperature. Operation at other temperature conditions may impact measurement accuracy when applying the preset calibration.

The preset calibration should be re-characterized every 12 months to maintain accuracy. This is accomplished via the Error Terms test/adjustment in the TME. Refer to [Chapter 3](#).

Under ideal conditions, a preset calibration and an OSL (open, short, load) calibration should give very similar results for measurements at the RF OUT port.

Two Port Calibration

Two port calibration applies only when S21 or Insertion Loss measurements are active.

There is no "built-in" or "preset" two port calibration in the analyzer. A normalize calibration must be performed before making two port measurements.

QuickCal

The QuickCal function mathematically "extends" the preset calibration to the end of a cable or adapter. It is a firmware only function; it does not involve analyzer hardware.

Firmware Related Information

General Description

The analyzer is based on the Windows CE¹ operating system. This is a closed system; no direct user access to the desktop of general operating system functions is provided.

The file system for Windows CE is maintained in flash memory on the A6 SOM board. There is limited access to the file system. Most memory is in protected region and not directly accessible by the user.

The user accessible memory is under UserData. See the "File Management" section of the FieldFox User's Guide for instructions on saving, recalling, and managing files in the unprotected memory.

User Accessible Files

- Directory structure below UserData in the A6 SOM board flash memory (approximately 20 MB).
- External USB flash memory plugged in the analyzer.
- External SD memory card plugged into the analyzer.

NOTE: When copying files, a "Copy_..." directory is created at the root of the destination device as the destination for the copied file(s). This characteristic generally makes it impossible to copy a file into the desired directory under UserData in the A6 SOM board flash memory. This limits the usefulness of copying files to or within UserData.

Operational Files

- Results from adjustments performed under TME (see **Chapter 3**)—not directly available to user.
- File resulting from CAT/NA user calibration—not directly available to user.
- Cal kit definition files—stored in UserData\calkits.
- Cable definition files—stored in UserData\Cables.
- Error log—not directly available to user. See "**Error Log**" further on in this section for accessing error log information.

1. Windows[®] and Windows CE[®] are U.S. registered trademarks of Microsoft Corporation.

Erase User Data Utility

A utility to erase all directories and files in the UserData directory is available. After the flash memory is erased, the boot process returns the UserData directories and files to the state as shipped from the factory. The System Information screen indicates the time and date of the most recent erase.

See [Chapter 8](#) for instructions on executing the Erase User data utility.

Error Log

See [Chapter 8](#) for instructions on viewing the error log.

The error log is cleared each time the analyzer is powered off.

Generally, an entry in the error log is created whenever an error message is displayed.

EXAMPLE: Attempting to set the frequency to a value of "." (a decimal point), will generate an entry in the error log.

Firmware Upgrades

Firmware upgrades are available on the Internet. Refer to instructions in the "Update FieldFox Firmware" section of the FieldFox User's Guide for details.

See [Chapter 8](#) for instructions on viewing the current firmware revision.

The following information will be included in the display.

- Firmware Release = FieldFox application firmware revision
- FPGA Rev = code revision for FPGA
- SBM Boot Rev = revision of boot code for System Microcontroller
- SBM Main Rev = revision of main code for System Microcontroller

A firmware upgrade includes three sections:

- the FieldFox application firmware and the Windows CE operation system on the A6 SOM board.
- the firmware in the System Monitor Microcontroller on the A5 system board.
- the FPGA code on the A5 system board.

The System Monitor firmware update and the FPGA code update are executed only if not up-to-date.

It is important to maintain power to the analyzer during the update process.

After unplugging the USB flash memory stick during the firmware upgrade process, wait for the analyzer to activate the CAT mode before operating the analyzer.

LAN Interface

See the “System Configuration” section of the FieldFox User’s Guide for details on reviewing and configuring LAN settings.

Currently the LAN interface supports only communication for the Data Link software and sending SCPI commands for service purposes.

The LAN interface supports Auto MDIX. When a LAN cable is connected to the FieldFox, if the other end of the cable supports Auto MDIX, there is no need for a cross-over cable.

There are two LEDs on the LAN connector. When there is successful communication over a LAN cable, both LEDs are active. If both LEDs are not active, consider using a cross-over cable.

6 Replaceable Parts

Information in This Chapter

This chapter:

- identifies the replaceable parts for the N9912A RF analyzer.
- includes several tables and illustrations to assist you in identifying the correct part for your analyzer.
- contains ordering information for new assemblies and rebuilt-exchange assemblies.

Chapter Six at-a-Glance

Section Title	Summary of Content	Start Page
Ordering Information	How to order a replaceable part from Keysight Technologies.	page 6-2
Assembly Replacement Procedure	The correct sequence for determining the failure of and replacing a defective assembly.	page 6-3
Replaceable Parts Listings	Tables with illustrations that list all replaceable parts in your analyzer:	page 6-4

Ordering Information

To order a part listed in the replaceable parts lists:

- include the part number
- indicate the quantity required
- Contact Keysight Technologies for instructions on where to send the order.
Refer to
“Contacting Keysight” on page 2-5.

To order a part **that is not listed** in the replaceable parts lists:

- include the instrument model number and complete instrument serial number
- include the description and function of the part
- indicate the quantity required
- Contact Keysight Technologies for instructions on where to send the order.
Refer to
“Contacting Keysight” on page 2-5.

Assembly Replacement Procedure

The following steps describe how to replace an assembly in the analyzer.

- Step 1.** Identify the faulty group. Begin with [Chapter 4, "Troubleshooting."](#) Follow up with the appropriate troubleshooting chapter that identifies the faulty assembly.
- Step 2.** Order a replacement assembly. Refer to this chapter for part numbers and ordering information.
- Step 3.** Replace the faulty assembly and determine what adjustments and performance tests are necessary. Refer to [Chapter 7, "Repair and Replacement Procedures."](#)
- Step 4.** Perform the necessary adjustments. Refer to [Chapter 3, "Tests and Adjustments."](#)
- Step 5.** Perform the necessary performance tests. Refer to [Chapter 3, "Tests and Adjustments."](#)

Replaceable Parts Listings

Entire Analyzer

Figure 6-1 Entire Analyzer, Exploded View

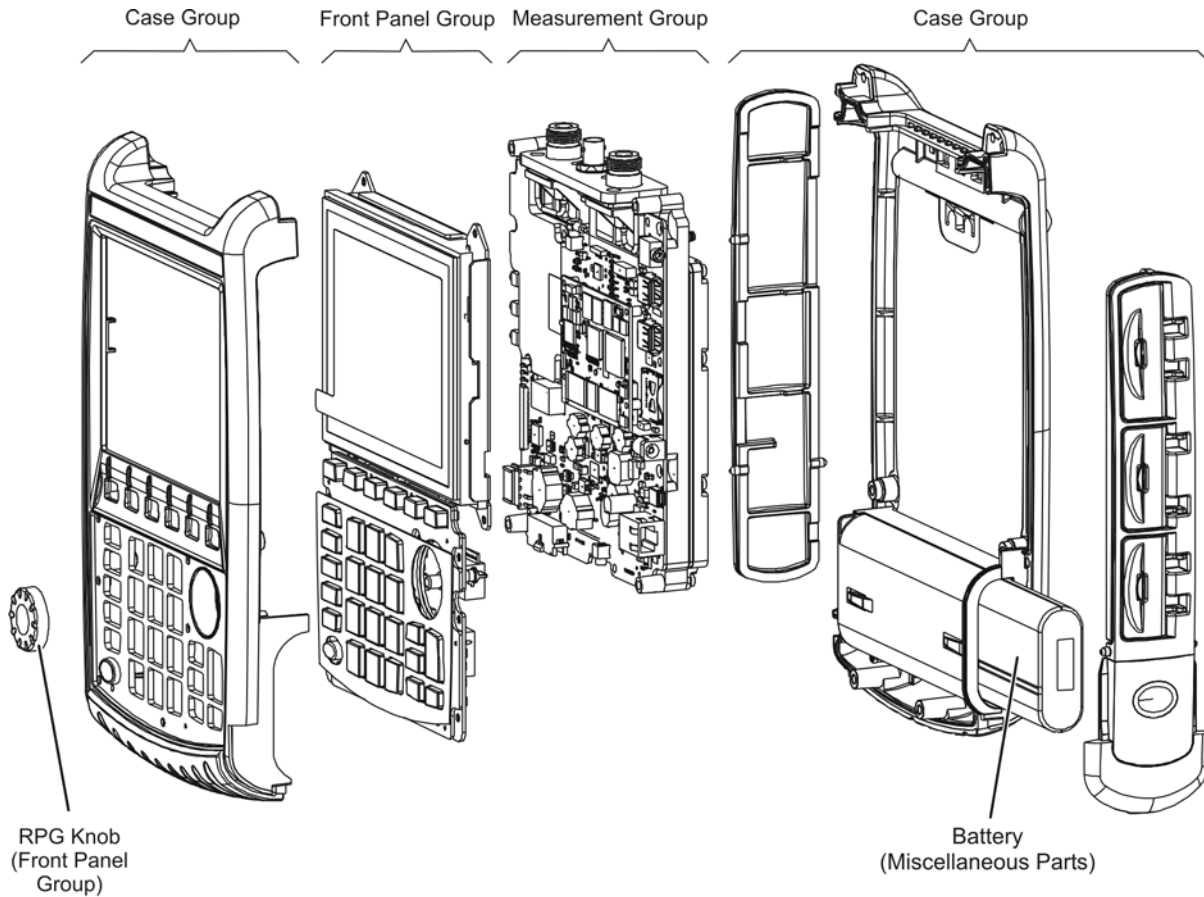

n9912_90003_601

Descriptions and part numbers for the assemblies and parts in each group shown in the above illustration can be found at the following locations:

- “Front Panel Group” on page 6-5
- “Measurement Group” on page 6-7
- “Case Group” on page 6-10

Miscellaneous parts and accessories not illustrated in any of these groups are listed under:

- “Miscellaneous Parts” on page 6-12

Front Panel Group¹

Reference Designator	Part Number	Qty	Description
Replacement Assemblies			
A3 Front Panel Board Assembly	N9912-60003	1	Front Panel Board Assembly—Includes: A3 front panel interface board
Separately Replaceable Individual Parts and Assemblies			
A1	Keypad assembly (Part of Front Enclosure Assembly and not separately replaceable; see “Case Group” on page 6-10.)		
A2	2090-0968	1	LCD assembly, 6.5-inch TFT VGA
(1)	LCD lens filter (Part of Front Enclosure Assembly and not separately replaceable; see “Case Group” on page 6-10.)		
(2)	N9912-00001	1	LCD shield (bracket)
(3)	0515-1521	13	Screw, machine, 90-deg flat head, M3.0 x 5 mm
(4)	1990-3613	1	RPG (Rotary Pulse Generator). Includes cable W12, nut, and washer.
(5)	W1312-40066	1	RPG knob
(6)	N9912-60017	1	Cable W13, A2 LCD to A3 front panel interface board
(7)	N9912-60006	1	Cable W14, ribbon, A3 front panel interface board to A5 system board
(8)	N9912-60016	1	Cable W11, A2 LCD to A5 system board
(9)	N9912-20035	1	Gap pad, LCD shield
(10)	N9912-20038	1	Gap pad, LCD shield
(11)	1420-0536	1	Battery, Lithium-ion (For Real Time Clock (RTC) backup.)

1. Each time the N9912A case is opened for any reason, you must order a **Repair and Re-assembly Kit**. See **“Miscellaneous Parts” on page 6-12.**

Figure 6-2 Front Panel Group, Exploded View

Front View

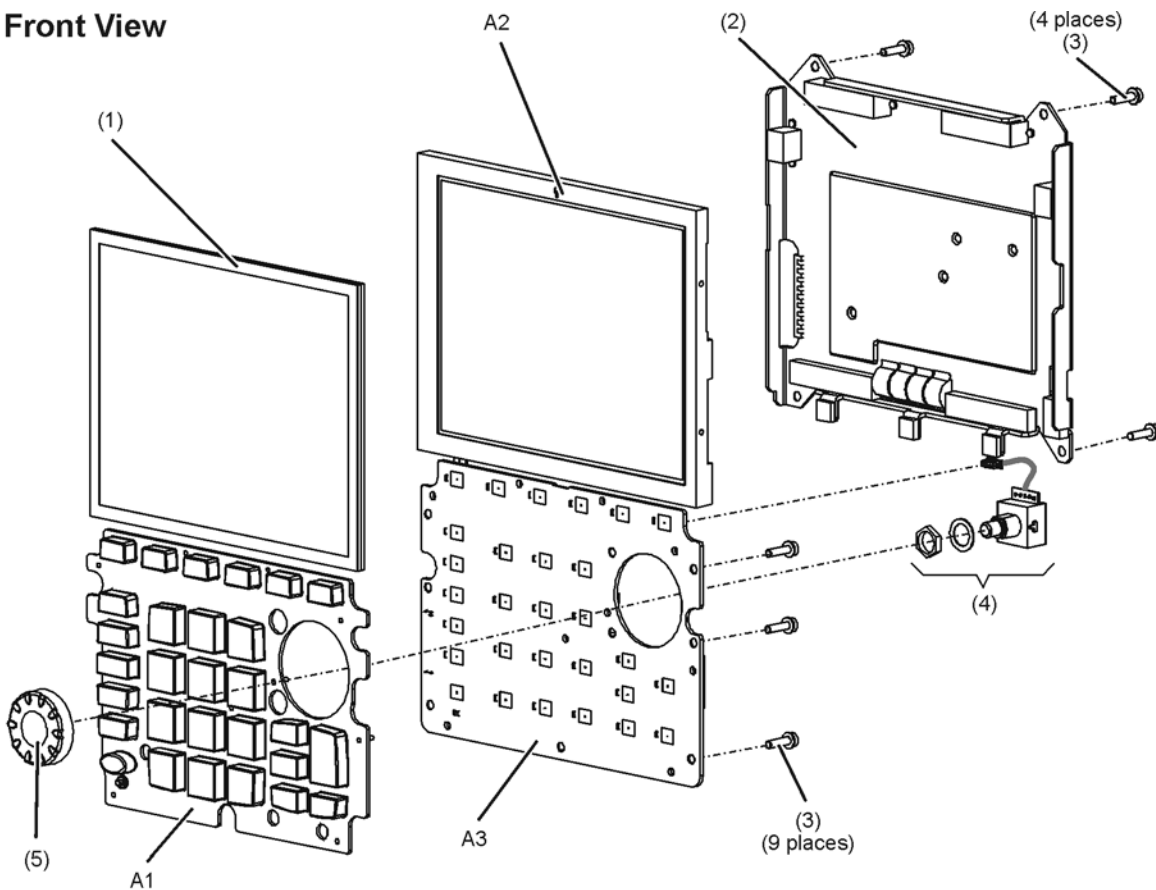

Rear View

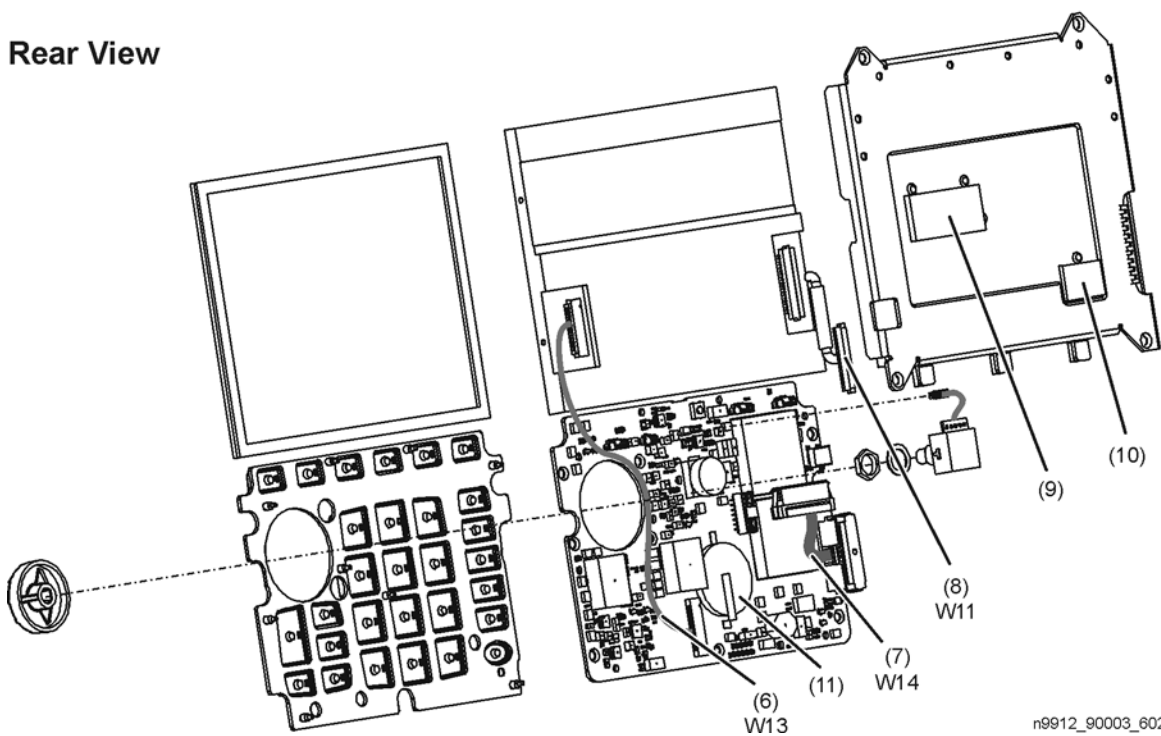

n9912_90003_602

Replaceable Parts
Replaceable Parts Listings

Measurement Group¹

Reference Designator	Part Number	Qty	Description
Replacement Assemblies			
RF Assembly	N9912-60002	1	RF Assembly—Includes: A4 RF board System gasket kit assembly, 2 gaskets (1) Polyiron (mixer house), w/pad (2) RFI wafer gasket, qty 2 (3) Insulator, qty 2 (4) Polyiron, front end (5) Polyiron, pre-amp (6) Polyiron, input (7) Shield, bottom, RF (8) Shield, top, RF (9) Cable W2, semi-rigid, RF IN (SA port) (10) Cable W1, semi-rigid, RF OUT (NA port) (11) Gap pad, 6 mm square (12) RFI O-ring, qty 2 (13) RFI strip, qty 4 (14) Adapter, coaxial, straight, female type-N to female 3.5 mm, qty 2 (15) Screw, machine w/crest cup washer, pan head, M3.0 x 12 mm, qty 30 (16) Screw, machine w/crest cup washer, pan head, M3.0 x 8 mm, qty 4 (17)
System Board Assembly	N9912-60032 N9923-60150 ^a	1	System Board Assembly—Includes: A5 system board System gasket kit assembly, 2 gaskets (1) Clamp, stick-on, qty 2 (18)
Coax Cable Assembly	N9912-60029	1	Coax Cable Assembly—Includes: Cable W4 and W6, RF, flexible, qty 2 (19) Spiral wrap, plastic (20)
RF Top Panel Assembly	N9912-60021	1	RF Top Panel Assembly—Includes: Panel, RF, machined (21) Connector cover (tethered cap), for type-N connector, qty 2 (22) Overlay, RF (23) Gasket, RF (24) Cable W3, RF coax with BNC connector, EXT TRIG/EXT REF connector (27) Washer, internal tooth, 15/32-inch (28) Nut, specialty, 15/32-inch - 32 thread (29)
Separately Replaceable Individual Parts and Assemblies			
A6	1150-8023	1	SOM Board, 532 MHz processor, 128 MB-SDRAM
	N9927-60100 ^a	1	Pre-programmed CPU Board (CPU2)
(1)	N9912-60019	1	System gasket assembly, 2 gaskets for A5 system board

1. Each time the N9912A case is opened for any reason, you must order a **Repair and Re-assembly Kit**. See **"Miscellaneous Parts" on page 6-12**.

Replaceable Parts
 Replaceable Parts Listings

Reference Designator	Part Number	Qty	Description
(4)	N9912-20033	1	Insulator, w/pad
(10)	N9912-20010	1	Cable W2, semi-rigid, RF IN (SA port)
(11)	N9912-20009	1	Cable W1, semi-rigid, RF OUT (NA port)
(13)	8160-0963	2	RFI O-ring
(15)	1250-2180	2	Adapter, coaxial, straight, female type-N to female 3.5 mm
(17)	0515-0372	4	Screw, machine w/crest cup washer, pan head, M3.0 x 8 mm
(22)	W1312-40069	2	Connector cover (tethered cap), for type-N connector
(25)	N9912-20116	1	System board top shield (25)
(26)	N9912-20028	1	Pad, A6 system board top shield to A2 LCD
(27)	8121-0964	1	Cable W3, RF coax with BNC connector, EXT TRIG/EXT REF connector
(28)	2190-0102	1	Washer, internal tooth, 15/32-inch
(29)	0590-1251	1	Nut, specialty, 15/32-inch - 32 thread
(30)	8121-1614	2	Cable W5 and W7, RF coax, flexible
(31)	0515-0374	4	Screw, machine w/crest cup washer, pan head, M3.0 x 10 mm
(32)	0515-0430	6	Screw, machine w/crest cup washer, pan head, M3.0 x 6 mm
(33)	0515-1940	4	Screw, machine w/patch lock, pan head, M2.5 x 6 mm
(34)	0515-2349	6	Screw, machine, 90-deg flat head, M3.0 x 14 mm

a. For Fieldfox Analyzer with serial number prefix starting with MY5607/SG5607/US5607.

Figure 6-3 Measurement Group, Exploded View

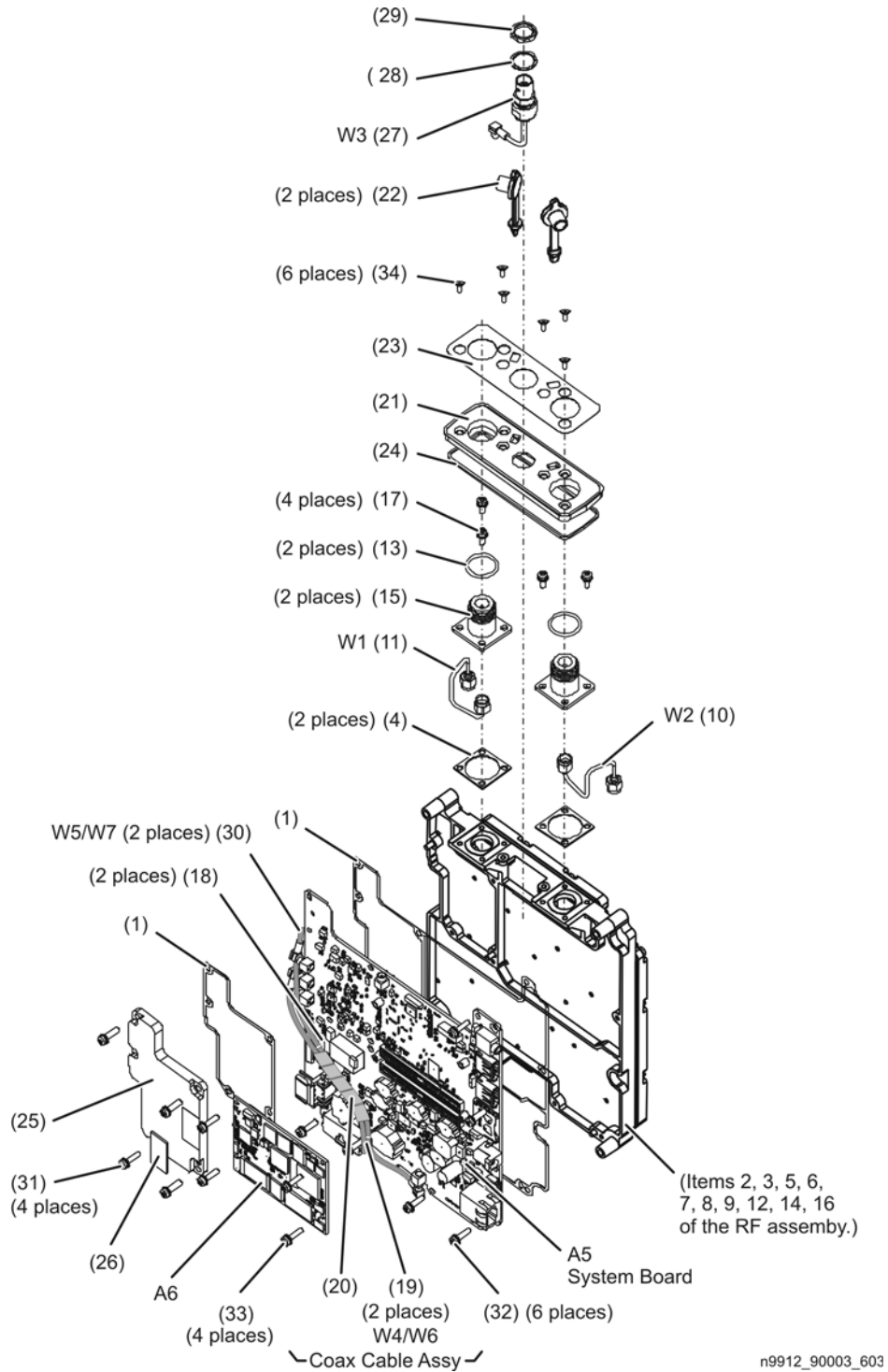

Replaceable Parts
Replaceable Parts Listings

Case Group¹

Reference Designator	Part Number	Qty	Description
Replacement Assemblies			
Front Enclosure Assembly	N9912-60020	1	Front Enclosure Assembly—Includes: Front case with A1 keypad installed (1) RFI O-strip, hollow (2) LCD lens filter (3) Keypad overlay (4) Model label, nameplate overlay, 4 GHz (5) Model label, nameplate overlay, 6 GHz (5)
Rear Enclosure Assembly	N9912-60022	1	Rear Enclosure Assembly—Includes: Rear case (6) RF gap pad (7) Rear panel overlay (8)
I/O Panel Assembly	N9912-60023	1	I/O Panel Assembly—Includes: System board connector panel (I/O side panel) (9) Overlay, I/O panel top (USB) (10) Overlay, I/O panel middle (SD) (11) Overlay, I/O panel bottom (LAN) (12)
Kick Stand Assembly	N9912-60028	1	Kick Stand Assembly—Includes: Kickstand (13) Friction hinge (14) Screw (for hinge), qty 4 (15) Hinge cover (16) Screw (for hinge cover), qty 4 (17) Spacer (for hinge), qty 2 (29)
Separately Replaceable Individual Parts and Assemblies			
(14)	3110-0654 Was 3110-0629	1	Friction hinge
(15)	0515-1940	4	Screw, machine w/patch lock, pan head, M2.5 x 6 mm
(16)	W1312-40068	1	Hinge cover
(17)	0515-5133	4	Screw, machine, button head, M3.0 x 8 mm
(18)	0515-5153	6	Screw, machine, w/flat washer, pan head, M3.0 x 35 mm
(19)	N9912-60007	1	Battery cable
(20)	W1312-40060	1	Battery door cover
(21)	N9912-40006	2	Hole plugs
(22)	0515-1521	2	Screw, machine, 90-deg flat head, M3.0 x 5 mm

1. Each time the N9912A case is opened for any reason, you must order a **Repair and Re-assembly Kit**. See **"Miscellaneous Parts" on page 6-12**.

Replaceable Parts
 Replaceable Parts Listings

Reference Designator	Part Number	Qty	Description
(23)	N9910-80002	1	Strap handle
(24)	W1312-40056	1	Blank side panel
(25)	1480-0793	4	Dowel pins
(26)	W1312-60048	1	Door, top (USB)
(27)	W1312-60049	1	Door, middle (SD)
(28)	W1312-60050	1	Door, bottom (LAN)
(29)	N9912-00003	2	Hinge spacer (see Figure 6-5). One spacer located between (14) and (6), and another spacer located between (16) and (6).

Figure 6-4 Case Group, Exploded View

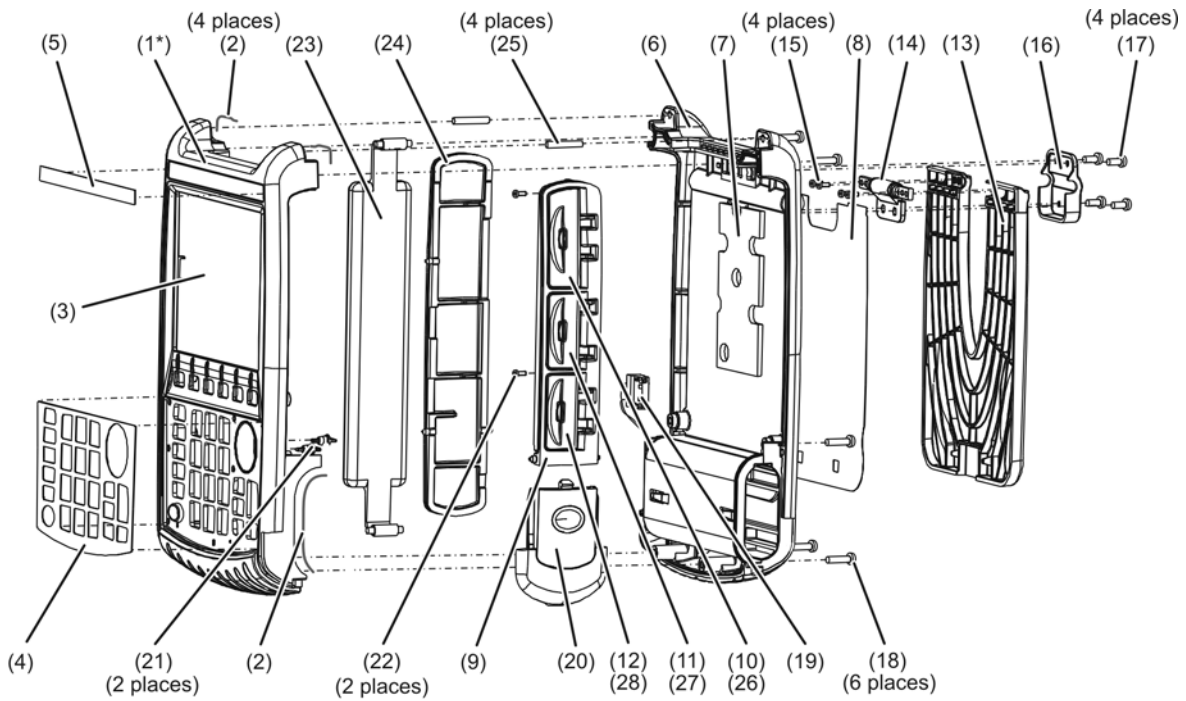

* The front case (1) comes with the A1 keypad installed.

n9912_90003_604

Figure 6-5 Hinge Spacer Locations

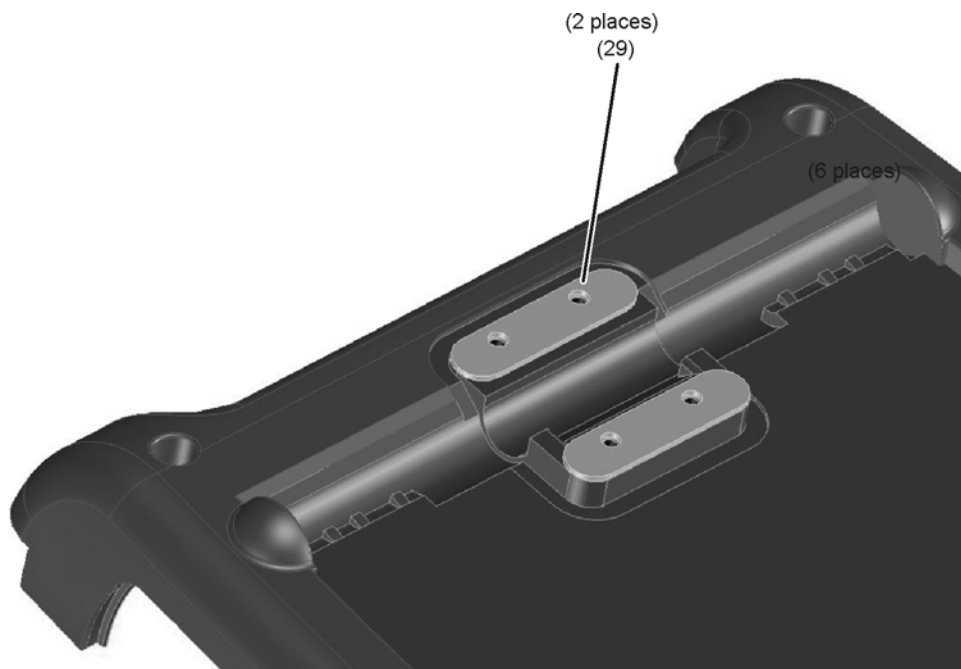

n9912_90003_605

Miscellaneous Parts

Table 6-1 Part Numbers for Miscellaneous Parts and Accessories

Description	Model or Part Number
Repair and Re-assembly Kit	
<p>IMPORTANT This kit is required each time the N9912A case is opened for any reason. The kit includes the following items, some or all of which are necessary to re-assemble the internal assemblies and the case, depending upon the depth of the repair.</p>	
Repair and Re-assembly Kit (Includes the following items.) Gasket, for blank side panel (larger size); qty 1 Gasket, for I/O side panel (smaller size); qty 1 Screw, machine, w/flat washer, pan head, M3.0 x 35 mm; qty 6 Screw, machine, 90-deg flat head, M3.0 x 5 mm; qty 15 Screw, machine w/crest cup washer, pan head, M3.0 x 6 mm; qty 6 Screw, machine w/crest cup washer, pan head, M3.0 x 10 mm; qty 4 Screw, machine w/patch lock, pan head, M2.5 x 6 mm; qty 4 Screw, machine, 90-deg flat head, M3.0 x 14 mm; qty 6 Tape, 1/4-inch x 1-inch, for LCD ribbon cable; qty 3	N9912-60027 N9912-40002 N9912-40003 0515-5153 0515-1521 0515-0430 0515-0374 0515-1940 0515-2349 N9912-20043
Service Tools	

Table 6-1 Part Numbers for Miscellaneous Parts and Accessories (Continued)

Description	Model or Part Number
T-8 TORX driver; set to 6 in-lb	N/A
T-10 TORX driver; set to 9 in-lb	N/A
5/16 inch, open-end torque wrench; set to 10 in-lb	N/A
7/16 inch, hex nut wrench or "nut driver"; set to 9 in-lb	N/A
9/16 inch, open-end torque wrench; set to 21 in-lb	N/A
Documentation	
Users' Guide. Can also be printed from the Keysight Web site.	N9912-90001
Quick Reference Guide	N9912-90002
Service Guide. (Not available in printed form. Part number is for reference only. Must be printed from the Keysight Web site.)	N9912-90003
ESD Supplies	
Adjustable antistatic wrist strap	9300-1367
Antistatic wrist strap grounding cord (5 foot length)	9300-0980
Static control table mat and earth ground wire	9300-0797
ESD heel strap	9300-1126
Battery ^a	
Lithium-ion, 11.1 V, rechargeable (LCD gauge)	1420-0908

a. Refer to **"Battery Disposal"** on page 1-8 for instructions on disposing of the old battery.

Replaceable Parts
Replaceable Parts Listings

7 Repair and Replacement Procedures

Information in This Chapter

This chapter contains procedures for removing and replacing the major assemblies of your Keysight Technologies PNA series microwave network analyzer.

Chapter Seven at-a-Glance

Section Title	Summary of Content	Start Page
Personal Safety Warnings	Warnings and cautions pertaining to personal safety.	page 7-2
Electrostatic Discharge (ESD) Protection	Information pertaining to ESD protection.	page 7-3
Assembly Replacement Sequence	A step-by-step procedure for how to identify the faulty assembly, replace it with a new one, and re-adjust your analyzer when done.	page 7-4
Table of Removal and Replacement Procedures	A table of removal and replacement procedures and the corresponding page number where they are located.	page 7-5
Removal and Replacement Procedures	The actual procedures for removing and replacing the major assemblies in your analyzer. The procedures occur in assembly reference designator numerical order.	See Table 7-1 on page 7-5 for specific procedures.
Post-Repair Procedures	A table of the proper tests, verifications, and adjustments to perform on your analyzer after repair.	page 7-44
Processor Upgrade Procedures	The procedures for removing and replacing the new processor for N9910HU-500 upgrade kit.	page 7-46

Personal Safety Warnings

WARNING

These servicing instructions are for use by qualified personnel only. To avoid electrical shock, do not perform any servicing unless you are qualified to do so.

WARNING

Danger of explosion if battery is incorrectly replaced. Replace only with the same or equivalent type recommended. Discard used batteries according to manufacturer's instructions.

Safety Earth Ground

WARNING

This is a Safety Class I product (provided with a protective earthing ground incorporated in the power cord). The mains plug shall only be inserted in a socket outlet provided with a protective earth contact. Any interruption of the protective conductor, inside or outside of the instrument, will make the instrument dangerous. Intentional interruption is prohibited.

CAUTION

Always use the three-prong AC power cord supplied with this product. Failure to ensure adequate grounding by not using this cord may cause product damage.

Electrostatic Discharge (ESD) Protection

CAUTION

Many of the assemblies in this instrument are very susceptible to damage from electrostatic discharge (ESD). Perform the following procedures only at a static-safe workstation and wear a grounded wrist strap.

This is important. If not properly protected against, electrostatic discharge can seriously damage your analyzer, resulting in costly repair.

To reduce the chance of electrostatic discharge, follow all of the recommendations outlined in ["Electrostatic Discharge Protection" on page 1-5](#), for all of the procedures in this chapter.

Assembly Replacement Sequence

The following steps show the sequence that you should follow to replace an assembly in the network analyzer.

- Step 1.** Identify the faulty group. Begin with [Chapter 4, "Troubleshooting."](#)
- Step 2.** Order a replacement assembly. Refer to [Chapter 6, "Replaceable Parts."](#)
- Step 3.** Replace the faulty assembly and determine what adjustments are necessary. Refer to ["Post-Repair Procedures"](#) in this chapter.
- Step 4.** Perform the necessary adjustments. Refer to [Chapter 3, "Tests and Adjustments."](#)
- Step 5.** Perform the necessary performance tests. Refer to [Chapter 3, "Tests and Adjustments."](#)

Removal and Replacement Procedures

Table 7-1 List of Procedures

Reference Designator or Name	Assembly Description	Location
Case parts	All enclosure case parts	page 7-7
RPG	RPG (part of front panel group)	page 7-21
RPG knob	RPG knob (part of front panel group)	page 7-21
RTC battery	Backup battery for real time clock (Soldered onto the A3 front panel interface board.)	page 7-27
Main battery	Primary power battery	page 7-6
A1	Keypad	page 7-26
A2	LCD	page 7-22
A3	Front panel interface board	page 7-26
A4	RF board	page 7-29
A5	System board	page 7-29
A6	SOM board	page 7-29

Removing and Replacing the Main Battery

Tools Required

None

NOTE

Refer to **"Battery Disposal"** on page 1-8 for important instructions on disposing of the old battery.

Replacing the Main Battery

1. Disconnect the power cord.
2. Remove the battery compartment door by pushing in on the detent and then sliding the door downwards.
3. Note the orientation of the battery for installation of the replacement.
4. Remove the old battery and install the new battery in the battery compartment.
5. Reinstall the battery compartment door by aligning it in position and then sliding it upwards until an audible click is heard.

Figure 7-1 Replacing the Main Battery

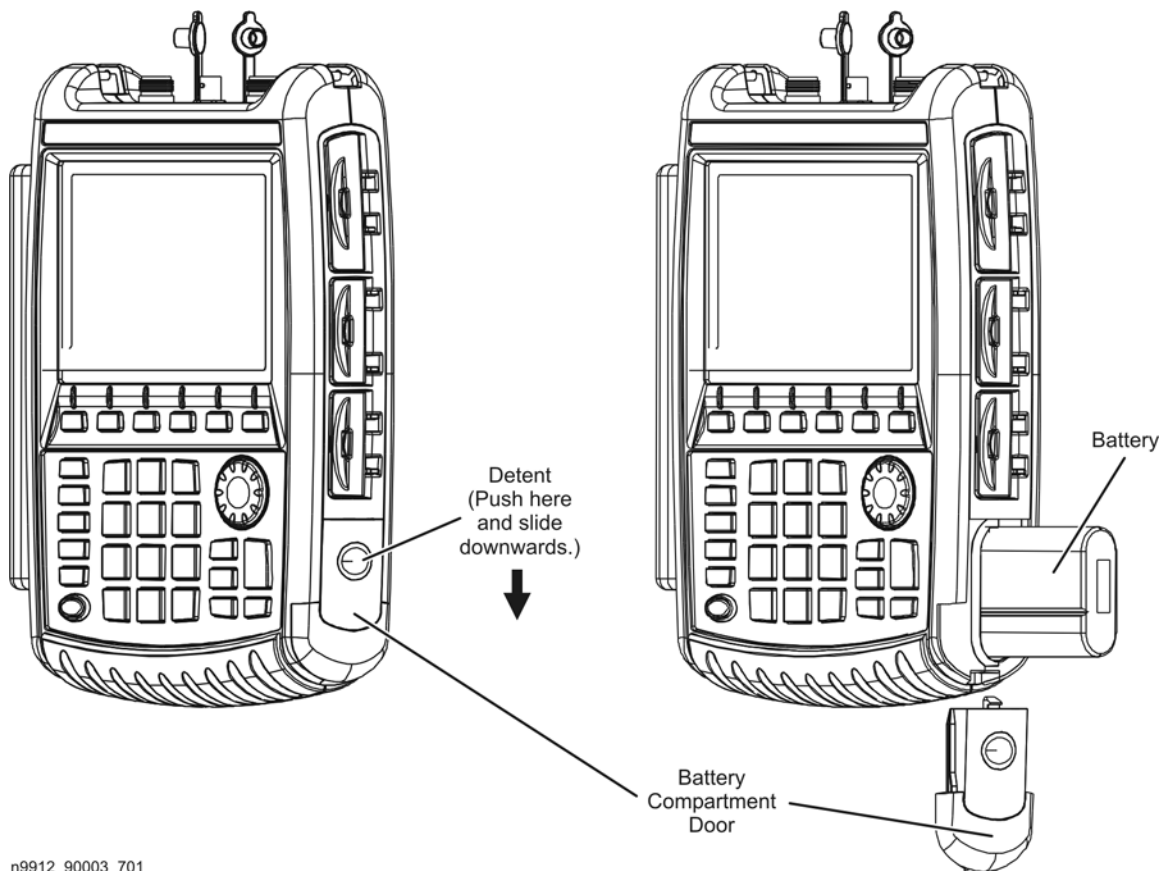

n9912_90003_701

Removing and Replacing the Case Group Parts

Tools Required

- T-8 TORX driver (set to 6 in-lb)
- T-10 TORX driver (set to 9 in-lb)
- Isopropyl alcohol (Use only in a well ventilated area.)
- **Repair and Re-assembly Kit**. Refer to “Miscellaneous Parts” on page 6-12.

WARNING

Before beginning any repair, disconnect the power cord.

Replacing the Kickstand, Hinge Cover, and Hinge

1. Remove, and discard, the four screws (item 1) from the kickstand hinge cover. New screws are provided in the **Repair and Re-assembly Kit**.

Figure 7-2 Replacing the Kickstand and Hinge Cover

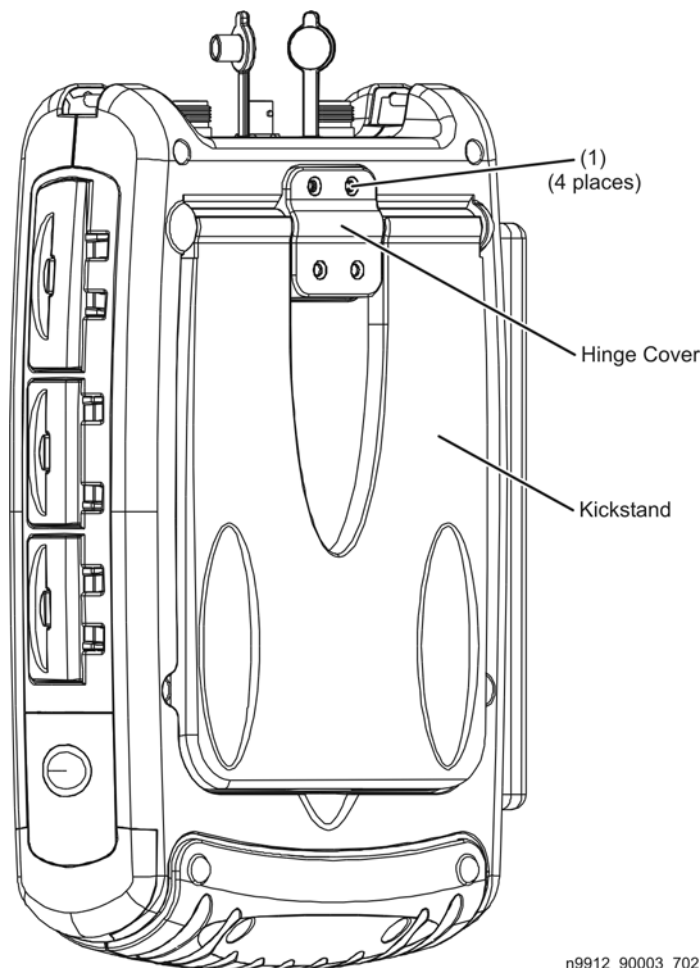

n9912_90003_702

2. To replace the entire kickstand assembly:
 - a. Lift the kickstand assembly off of the rear case and discard it.
 - b. Place the new kickstand assembly on the rear case.
 - c. Place the new hinge cover in position and secure it with four new screws. A new hinge cover and new screws are provided in the **Repair and Re-assembly Kit**.
3. To replace the hinge cover:
 - a. Position the new hinge cover in place and install four new screws. New screws are provided in the **Repair and Re-assembly Kit**.
4. To replace the hinge:
 - a. Lift the kickstand assembly off of the rear case.
 - b. Remove and discard the four hinge attachment screws (item 2).
 - c. Place the new hinge in position and install with four new screws. New screws are provided in the **Repair and Re-assembly Kit**.
 - d. Place the kickstand assembly in place on the rear case and reinstall the hinge cover with new screws provided in the **Repair and Re-assembly Kit**.

Figure 7-3 Replacing the Hinge

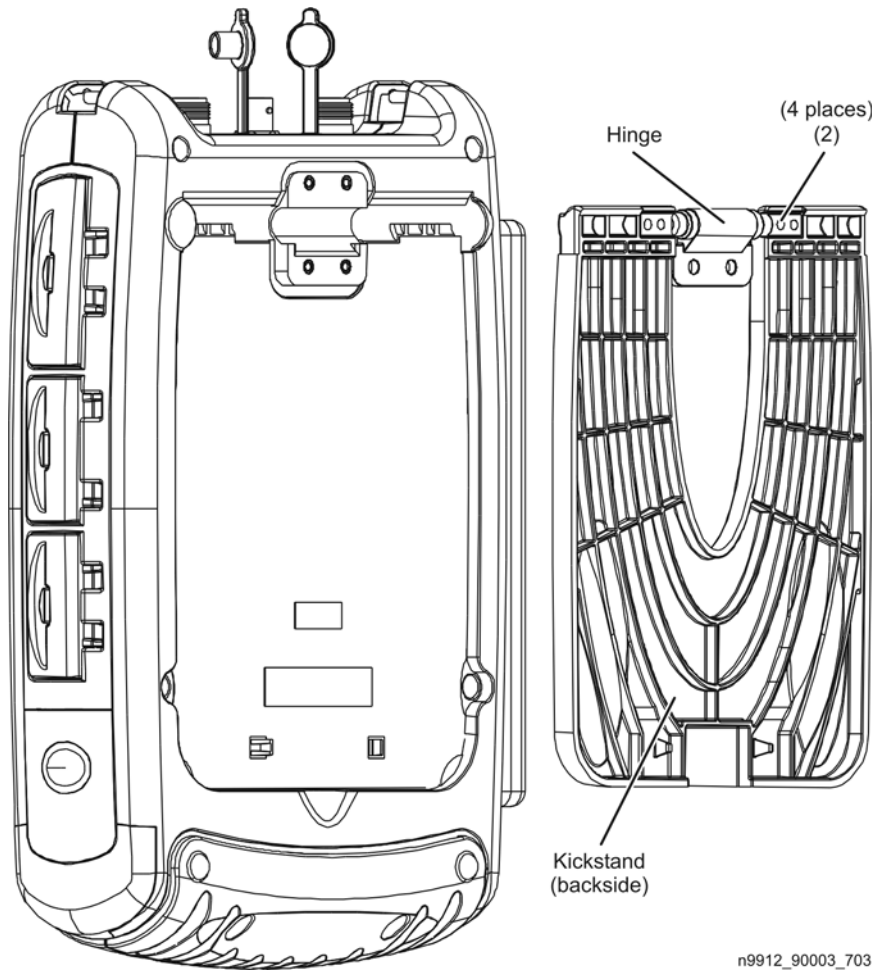

Separating the Front and Rear Cases

1. Remove the battery. Refer to **“Removing and Replacing the Main Battery”** on page 7-6.
2. Loosen the six screws (item 3) that secure the RF top panel. It should not be necessary to remove these screws, just loosen them.
3. Remove, and discard, the six screws (item 4) that secure the rear case to the front case. New screws are provided in the **Repair and Re-assembly Kit**.

Figure 7-4 Separating the Front and Rear Cases (1)

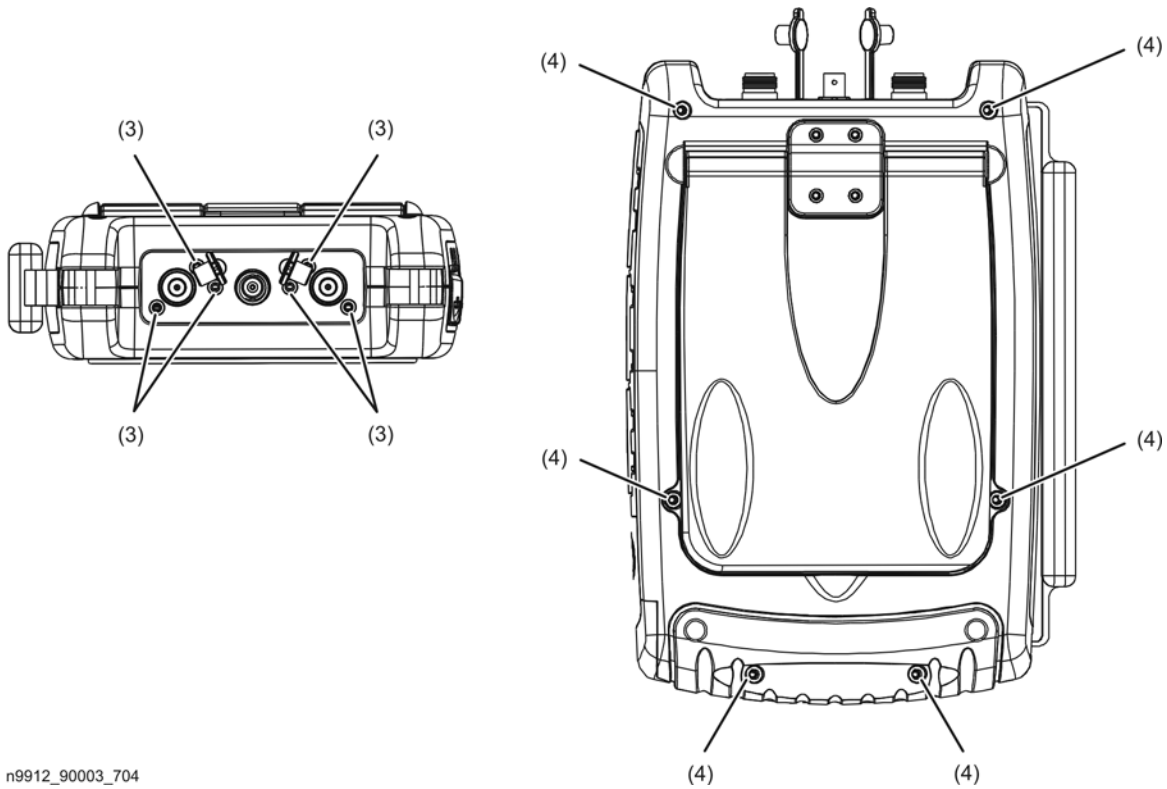

n9912_90003_704

4. Separate the cases and position the rear case to one side, as shown in [Figure 7-5](#), to allow access to the blank side panel and strap handle.
5. Remove the strap handle from the two dowel pins.
6. Remove the blank side panel from the groove in the front case.

Figure 7-5 Separating the Front and Rear Cases (2)

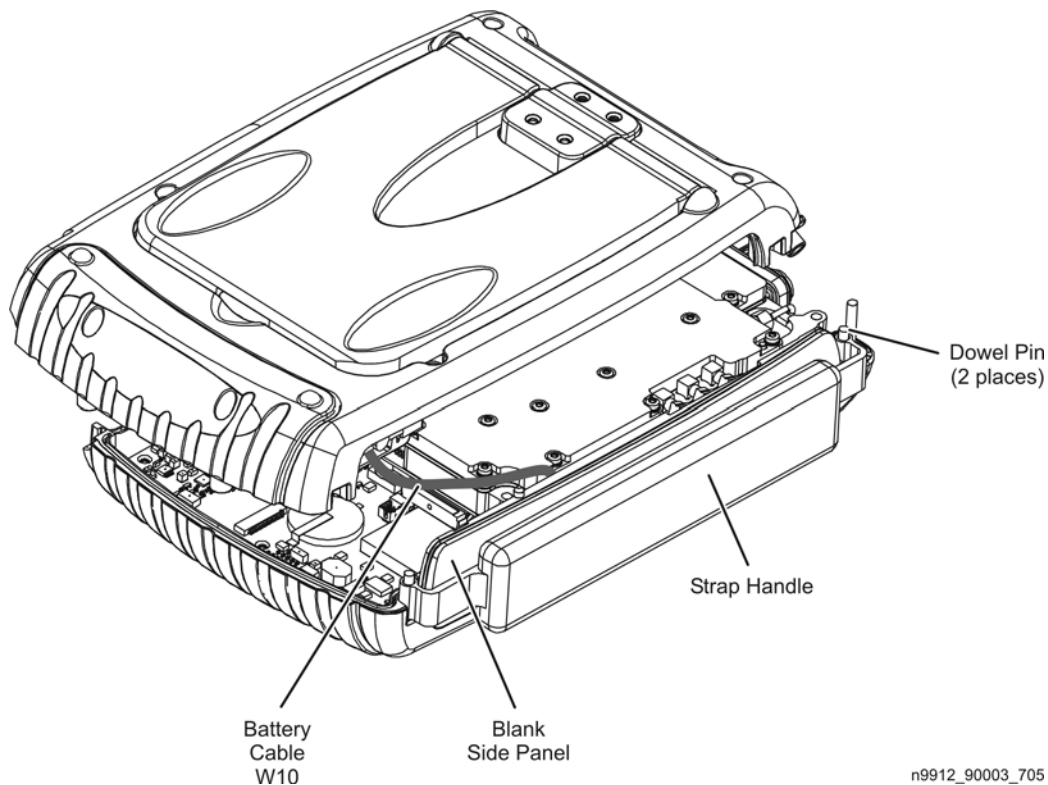

n9912_90003_705

7. Position the cases side-by-side as shown in [Figure 7-6](#).
8. Unplug the battery cable, W10, from the A5 system board at the location indicated.
9. The front and rear cases are now completely separated.
10. Remove the blank side panel by lifting it from the groove in the front case.

NOTE

If the FieldFox serial number is below xx4910xxxx, temporarily remove the LCD shield and verify that two strips of adhesive tape are in place as shown in [Figure 7-15 on page 7-25](#). To remove the LCD shield, follow [step 2a on page 7-22](#). If the two strips of adhesive tape are not in place, install them by following [step 2h on page 7-23](#).

Figure 7-6 Separating the Front and Rear Cases (3)

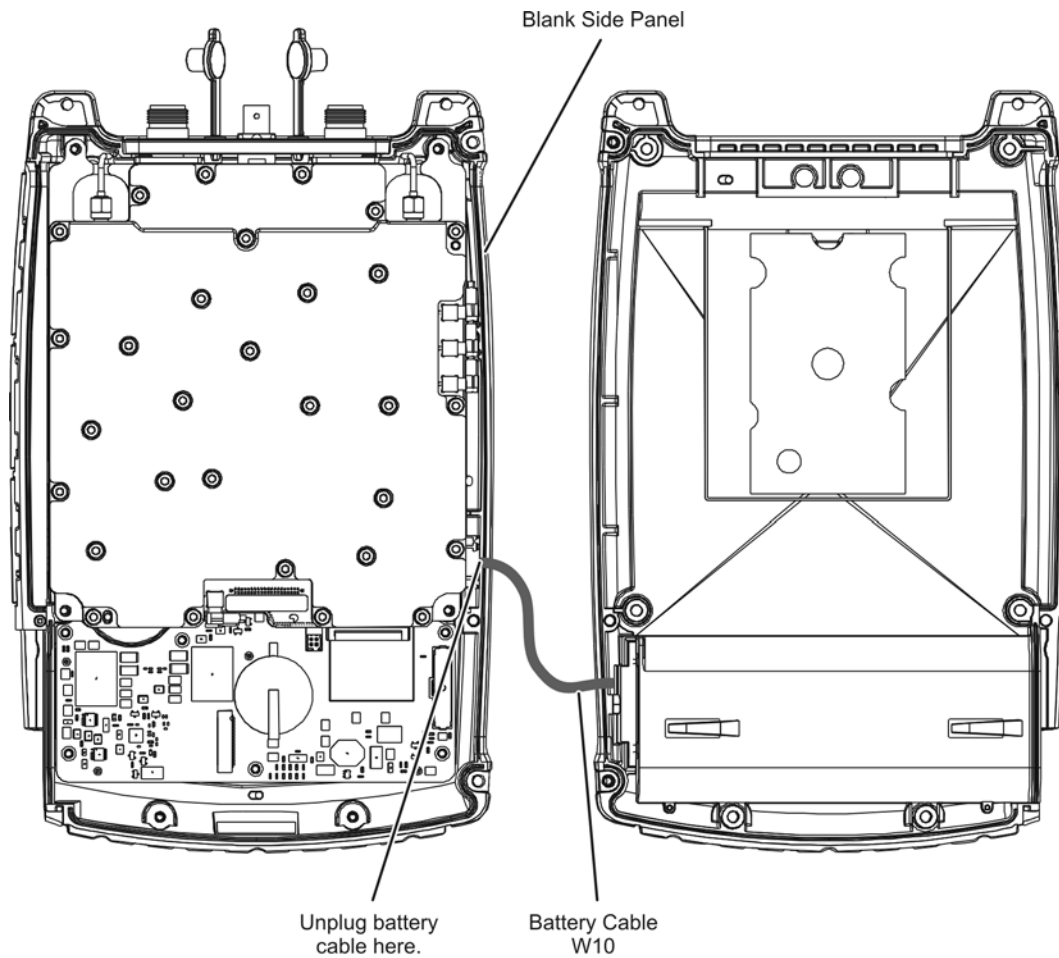

n9912_90003_706

Replacing the Battery Cable

1. Separate the front and rear cases. See ["Separating the Front and Rear Cases"](#) on page 7-9.
2. Note the orientation of the cable for installation of the new cable, then, using a small flat-blade screwdriver to move the cable connector, release the retention clips on the cable connector and remove the cable from the rear case.

Figure 7-7 Replacing the Battery Cable

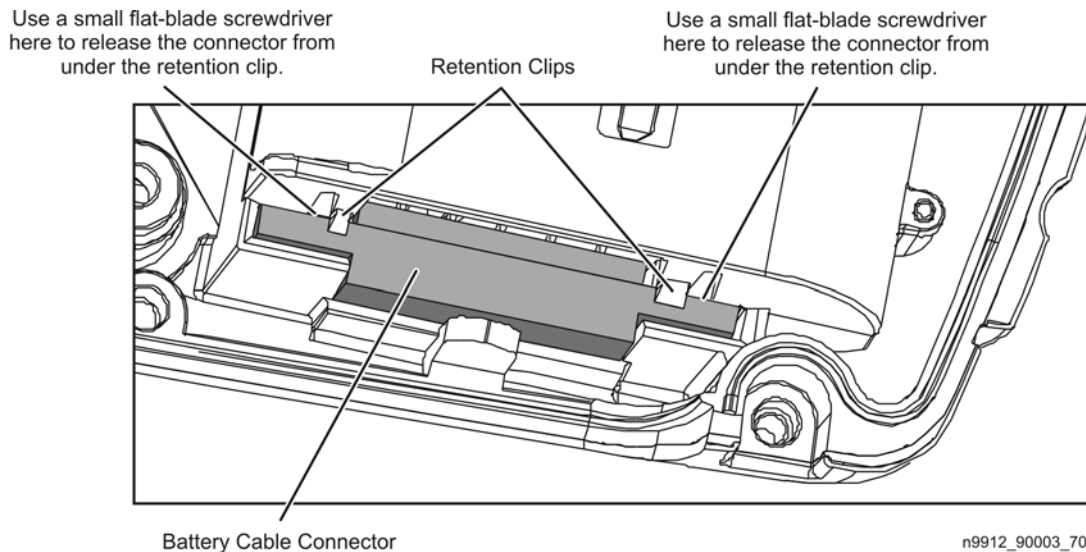

3. When installing the new battery cable, make sure that the connector snaps into place.
4. Reinstall the rear case onto the front case. See [Combining the Front and Rear Cases](#).

Replacing the Rear Case

1. Separate the front and rear cases. See [Separating the Front and Rear Cases](#).
2. Carefully remove the serial number label and the Windows CE label from the back of the old rear case and apply the labels to the new rear case.
3. Remove the kickstand assembly from the old rear case and install it on the new rear case. See [Replacing the Kickstand, Hinge Cover, and Hinge](#).
4. Remove the battery cable from the old case and install it in the new case. See [Replacing the Battery Cable](#).
5. Install the new rear case onto the front case. See [Combining the Front and Rear Cases](#).

Replacing the Strap Handle

1. Separate the front and rear cases to the positions shown in [Figure 7-5](#). See [Separating the Front and Rear Cases](#).
2. Note the orientation of the strap handle, then lift it off of the dowel pins at each end.
3. Slip the new strap handle over the dowel pins.
4. Reinstall the rear case onto the front case. See [Combining the Front and Rear Cases](#).

Replacing the I/O Side Panel, Doors, and Gasket

1. Separate the front and rear cases. See **“Separating the Front and Rear Cases”** on page 7-9.
2. Remove the measurement group assemblies (RF top panel assembly, A4 RF board, A5 system board, and A6 SOM board) as one unit with the I/O panel attached, but do not disconnect cable W11 from between the A2 LCD and the A5 system board. Refer to **“Removing and Replacing the Measurement Group Assemblies”** on page 7-29.
3. Remove the two screws (item 5) that secure the I/O side panel to the A5 system board and remove the I/O side panel.

Figure 7-8 Replacing the I/O Side Panel

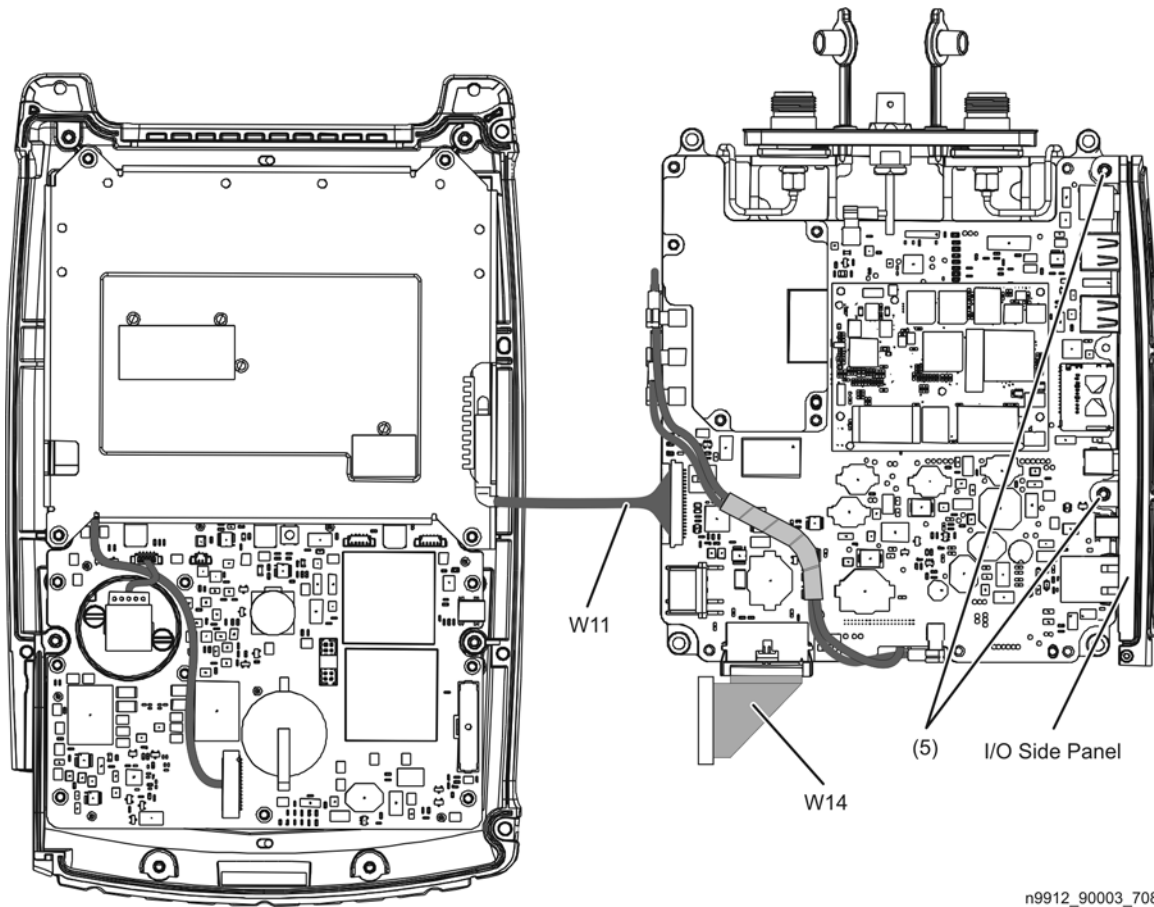

n9912_90003_708

4. Remove the three doors from the old I/O side panel:
 - a. Open each door to its stopping point, then GENTLY force it beyond its stopping point to separate it from the panel.
5. Install the three doors in the new I/O side panel:
 - a. Place each door in its respective opening with the hinges aligned with the hinge slots in the side panel.

- b. Press the hinges into their slots until they snap into place.

Figure 7-9 Replacing the I/O Side Panel Doors and Gasket

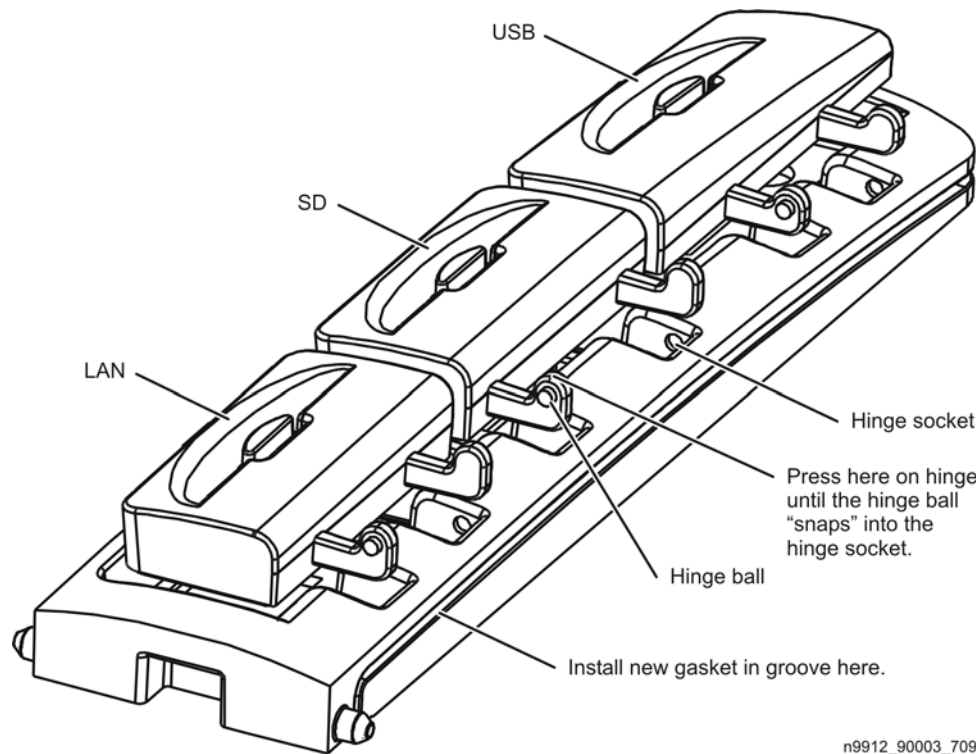

6. Before installing the new I/O side panel, or when reinstalling the existing I/O side panel, install a new gasket in the groove around the perimeter of the panel.

If an old gasket must be removed, use tweezers being careful not to damage the groove.

Start in the groove near the flat end of the side panel. Be careful not to stretch or damage the gasket in any way. Also, make sure there is no slack in the gasket. A new gasket is provided in the [Repair and Re-assembly Kit](#) (see [page 6-12](#)). It is the smaller of the two gaskets provided in the kit.

7. To install the new I/O side panel, place it in position on the A5 system board and reinstall the two attachment screws. See [Figure 7-8](#).
8. Reinstall the measurement group assemblies (RF top panel assembly, A4 RF board, A5 system board, and A6 SOM board) as one unit with the new I/O panel attached.
9. Reinstall the rear case onto the front case. See [Combining the Front and Rear Cases](#).

Replacing the Front Case (including the A1 Keypad)

1. Separate the front and rear cases. See [Separating the Front and Rear Cases](#).

2. Remove the measurement group assemblies (RF top panel assembly, A4 RF board, A5 system board, and A6 SOM board) as one unit with the I/O panel attached. Refer to [“Removing and Replacing the Measurement Group Assemblies” on page 7-29](#).
3. Remove the front panel group assemblies (A2 LCD, A3 front panel interface board, and RPG). Refer to [“Removing and Replacing the Front Panel Group Assemblies” on page 7-21](#).

Figure 7-10 Replacing the Front Case

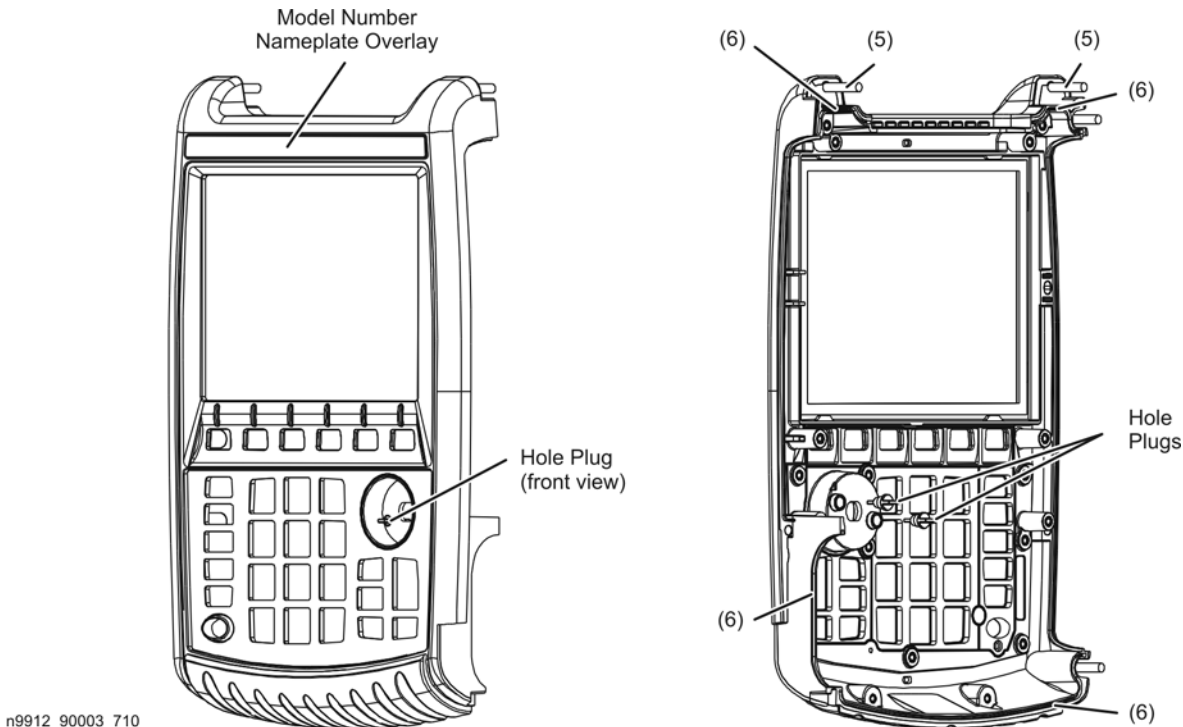

4. Carefully remove the serial number label from the inside bottom of the old front case and apply the label to the new front case.
5. Choose the appropriate model number nameplate overlay for your analyzer, remove the protective backing to expose the adhesive, and adhere it in the location shown.
6. Remove the dowel pins (item 5) from the old front case and install them in the new case. The other two dowel pins should already be installed in the case.
7. Make sure that the gaskets (item 6) are all in place in the grooves, that there are no gaps, and that they are not damaged in any way.
8. Refer to [“Removing and Replacing the Front Panel Group Assemblies” on page 7-21](#) to reinstall the front panel group assemblies removed in [step 3](#).

9. Refer to ["Removing and Replacing the Measurement Group Assemblies"](#) on page 7-29 to reinstall the measurement group assemblies removed in step 2.
10. Reinstall the rear case onto the front case. Refer to ["Combining the Front and Rear Cases"](#) on page 7-17.

Combining the Front and Rear Cases

1. Install a new gasket on the blank side panel being careful not to stretch it or to damage it in any way. Also, make sure there is no slack in the gasket. A new gasket is provided in the [Repair and Re-assembly Kit](#) (the blank side panel uses the larger of the two gaskets provided). If an old gasket must be removed, carefully remove it with tweezers being careful not to damage the groove.
2. If a new gasket has not been installed on the I/O side panel, install it at this time. It will be necessary to remove the I/O side panel from the A5 system board. Refer to ["Replacing the I/O Side Panel, Doors, and Gasket"](#) on page 7-14 for instructions.
3. Position the front and rear cases side-by-side as shown.
4. Plug the battery cable, W10, into the A5 system board as indicated.

Figure 7-11 Combining the Front and Rear Cases (1)

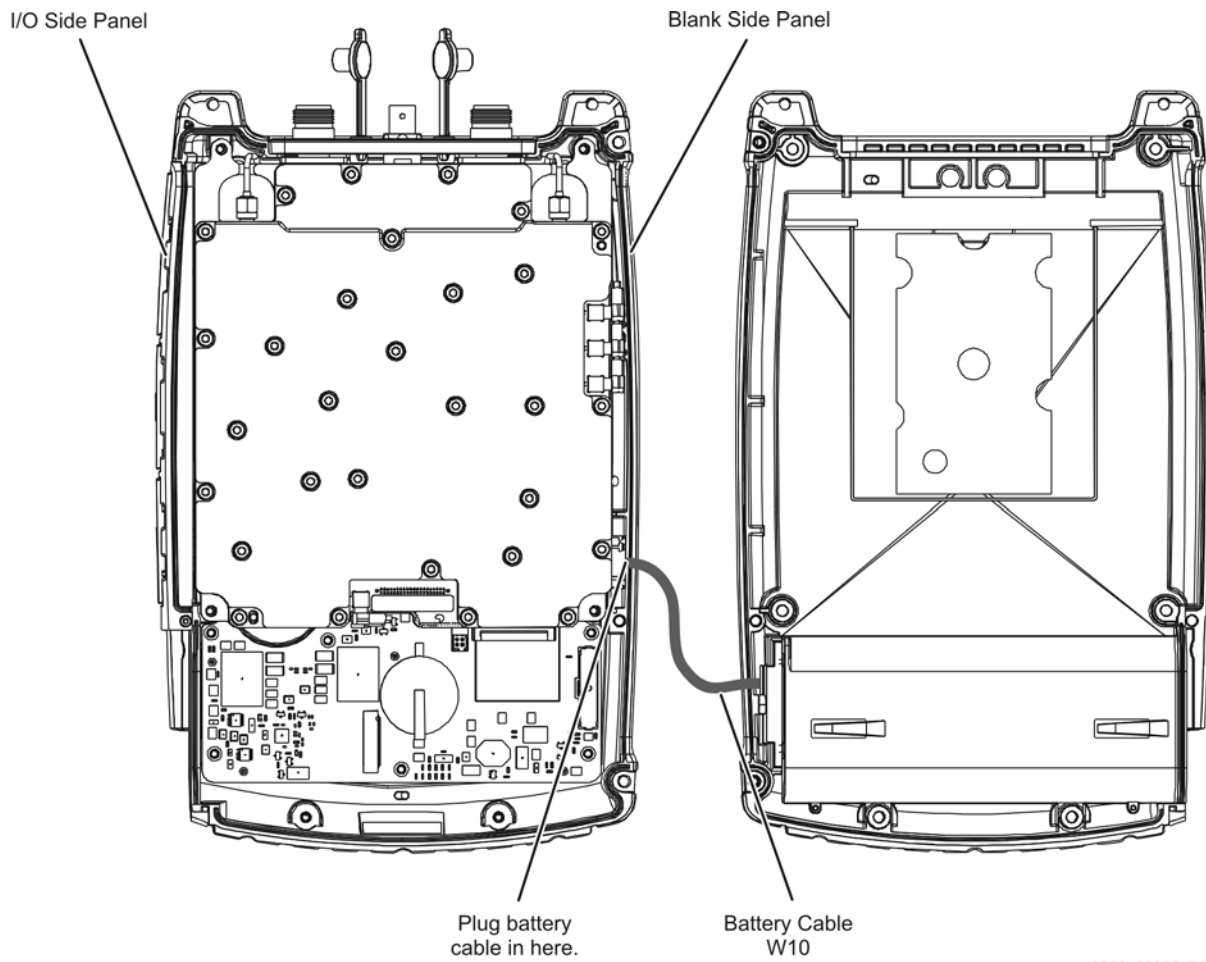

n9912_90003_711

5. Position the rear case on top of the front case and to one side as shown.
6. Place the blank side panel in the groove in the front case being careful not to damage the gasket.
7. Position the strap handle over the two dowel pins as shown.

Figure 7-12 Combining the Front and Rear Cases (2)

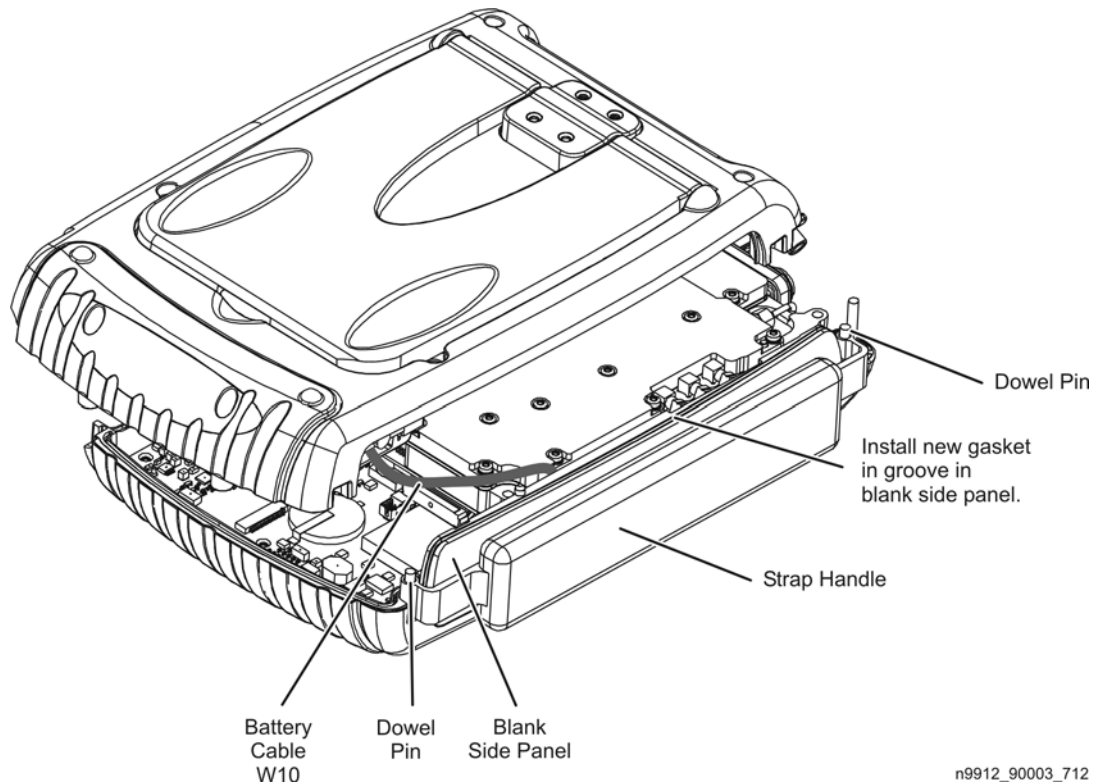

8. Position the rear case directly over, and aligned with, the front case and the side panels as shown.
9. Make sure the battery cable is tucked in between the measurement group assemblies and the blank side panel and that it is not in the path of the screw hole indicated.
10. Firmly press the cases together being careful not to damage the gaskets.
11. Install six new screws (item 7) to secure the rear case to the front case. These new screws are provided in the **Repair and Re-assembly Kit**.
12. Tighten the six screws (item 8) that secure the RF top panel.

Figure 7-13 Combining the Front and Rear Cases (3)

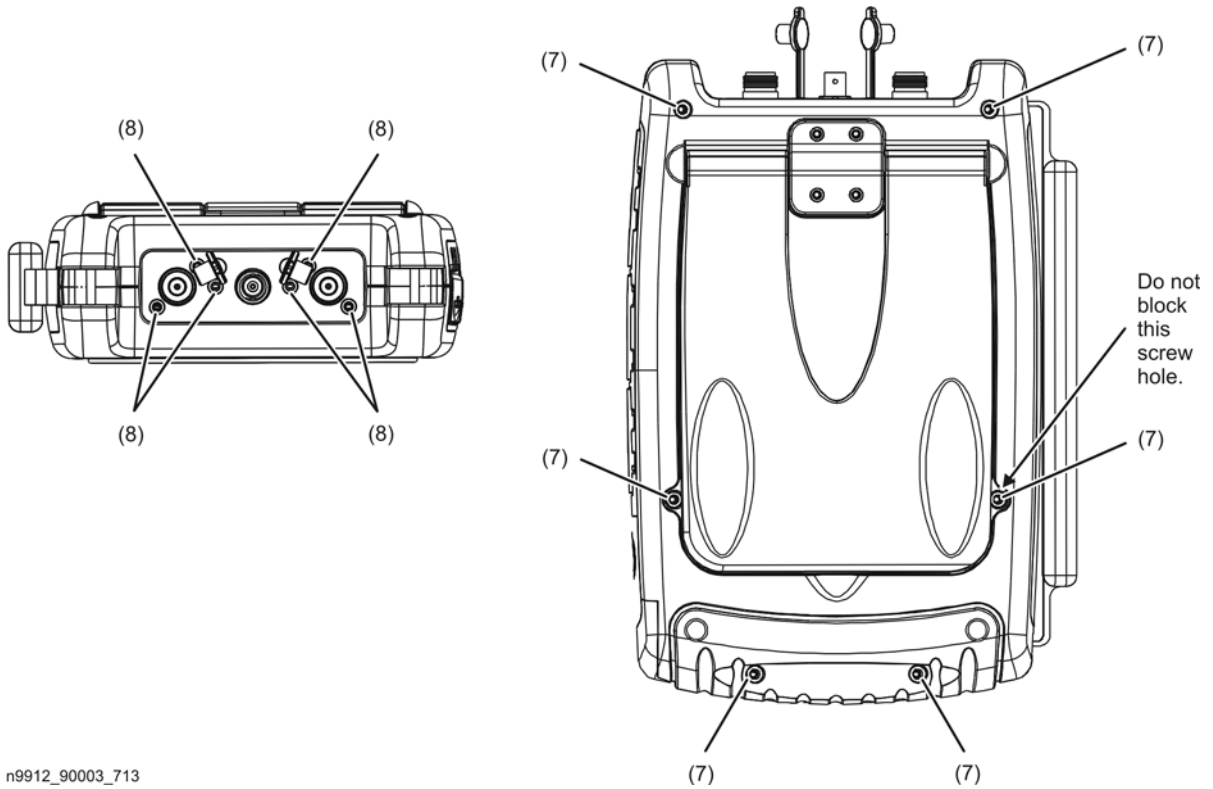

n9912_90003_713

13. Reinstall the battery. Refer to "Removing and Replacing the Main Battery" on page 7-6.

Removing and Replacing the Front Panel Group Assemblies

Tools Required

- T-8 TORX driver (set to 6 in-lb)
- T-10 TORX driver (set to 9 in-lb)
- 7/16-inch hex nut wrench or “nut driver” (set to 9 in-lb)
- **Repair and Re-assembly Kit**. Refer to **“Miscellaneous Parts” on page 6-12**.
- Soldering tool (Required only for RTC battery replacement.)

WARNING

Before beginning any repair, disconnect the power cord.

Pre-replacement Procedure

1. Separate the front and rear cases. Refer to **“Separating the Front and Rear Cases” on page 7-9**.
2. Remove the measurement group assemblies (RF top panel, A4 RF board, A5 system board, and A6 SOM board) as one unit with the I/O panel attached. Refer to **“Removing and Replacing the Measurement Group Assemblies” on page 7-29**.

Replacing the RPG and RPG Knob

1. Perform the steps under **“Pre-replacement Procedure” on page 7-21**.
2. Remove the two hole plugs from the back side of the front case, next to the RPG.
3. To replace the RPG knob:
 - a. Insert a round shaft, such as a screwdriver shaft, into the exposed holes and push the RPG knob off of the RPG shaft to the front side of the front case.
 - b. Install a new knob by aligning the D-shaped detent in the knob with the D-shape on the shaft and push the knob into position.
4. To replace the RPG:
 - a. Remove the RPG knob. Refer to **step 3a** of this procedure.
 - b. Disconnect the RPG cable, W12, from the A3 front panel interface board.
 - c. Using a 7/16-inch hex nut wrench, remove the hex nut from the RPG shaft.
 - d. Pull the RPG out the back side of the front case and retrieve the lock washer from the front side.

- e. To install a new RPG, reverse the above steps. A new cable, nut, and washer are included with the new RPG. When reinstalling the RPG cable, W12, bend the cable toward the right side on top of the display to front panel interface board cable.
5. Reinstall the hole plugs in the front case. Apply one drop of isopropyl alcohol on each hole plug to lubricate it, making it easier to install. Use alcohol only in a well ventilated area. View the hole plugs from the front to ensure that they are fully seated. These hole plugs must be installed to maintain water-tight integrity.
6. Reinstall the RPG knob. Refer to [step 3.b](#) of this procedure.
7. Perform the steps under **"Post-replacement Procedure"** on [page 7-28](#).

Figure 7-14

Replacing the RPG and RPG Knob

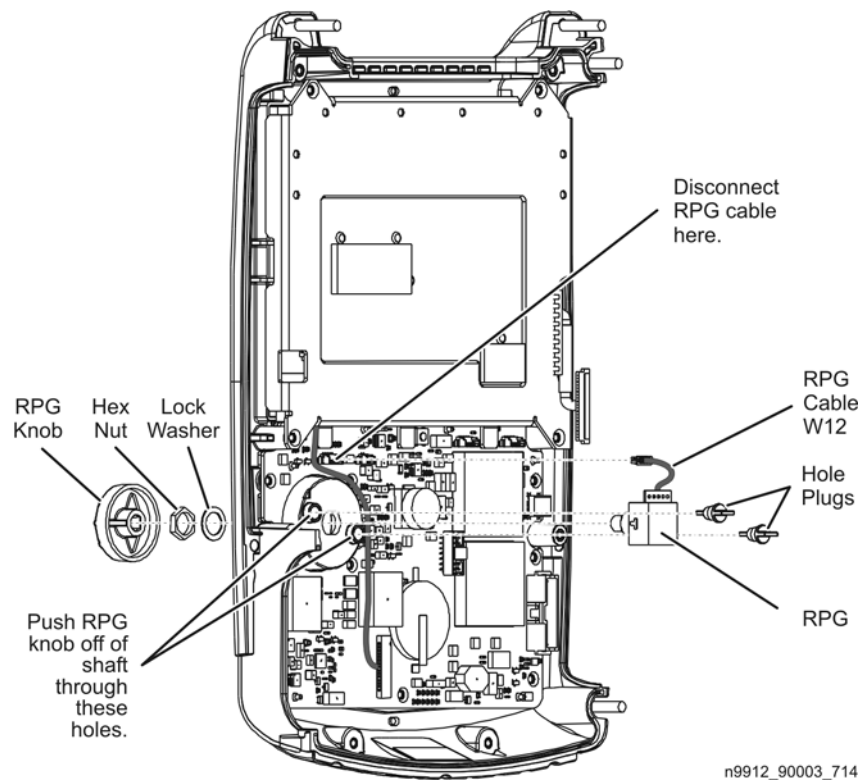

Replacing the A2 LCD, the LCD Shield, and LCD Cables

1. Perform the steps under **"Pre-replacement Procedure"** on [page 7-21](#).
2. To replace the LCD shield:
 - a. Remove the four screws (item 1) that attach the LCD shield and discard them. New screws are provided in the **Repair and Re-assembly Kit**.
 - b. Lift the LCD shield off of the A2 LCD.

- c. Install new gap pads on the new LCD shield in the locations shown. Refer to [Figure 7-15](#) and [Figure 7-8 on page 7-14](#) for placement of gap pads.
 - d. Place the new LCD shield in position on the A2 LCD and secure it with four new screws (item 1). These screws are provided in the [Repair and Re-assembly Kit](#).
3. To replace the LCD cables and the A2 LCD:
- a. Remove the LCD shield. Refer to [step 2.a](#) and [step 2.b](#) of this procedure.
 - b. Disconnect the A2 LCD to A3 FPIB cable, W13, at the A2 LCD. If replacing only this cable:
 1. Disconnect the cable at both ends.
 2. Remove the cable from beneath the RPG cable, W12.
 3. Route the new cable beneath the RPG cable as shown and re-connect both ends.
 4. Bend the RPG cable toward the right side as shown.
 5. Skip to [step 3.h](#).
 - c. Note the location of the adhesive tape over the connector on the A2 LCD to A5 system board cable, W11. Remove the tape and disconnect the cable. If replacing only this cable:
 1. Connect the new cable.
 2. Skip to [step 3.h](#).
 - d. Remove the A2 LCD from the front case.
 - e. Place the new A2 LCD in position and re-connect the cables.
 - f. Place a strip of adhesive tape over the LCD connector end of the A2 LCD to A5 system board cable W11, in the same location as the old strip and as shown. A new strip of adhesive tape is provided in the [Repair and Re-assembly Kit](#).
 - g. Connect cable W13 to the A2 LCD.
 - h. There are two identical connectors, CN3 and CN4, near the connector for cable W13. A strip of adhesive tape should cover each connector as shown in [Figure 7-15](#). If not, apply tape strips by cutting a strip of adhesive tape (provided) in half and applying one half to each connector as shown in [Figure 7-15](#). Press down firmly on the tape to conform it to the contours of the connectors and to ensure proper adhesion. The strip of adhesive tape is part of the N9912-60027 [Repair and Re-assembly Kit](#).

Repair and Replacement Procedures
Removing and Replacing the Front Panel Group Assemblies

- i. Reinstall the LCD shield with four new screws provided in the **Repair and Re-assembly Kit**. Refer to **step d on page 7-23** of this procedure.
4. Perform the steps under **"Post-replacement Procedure"** on page 7-28.

Figure 7-15 Replacing the A2 LCD, the LCD Shield, and LCD Cables

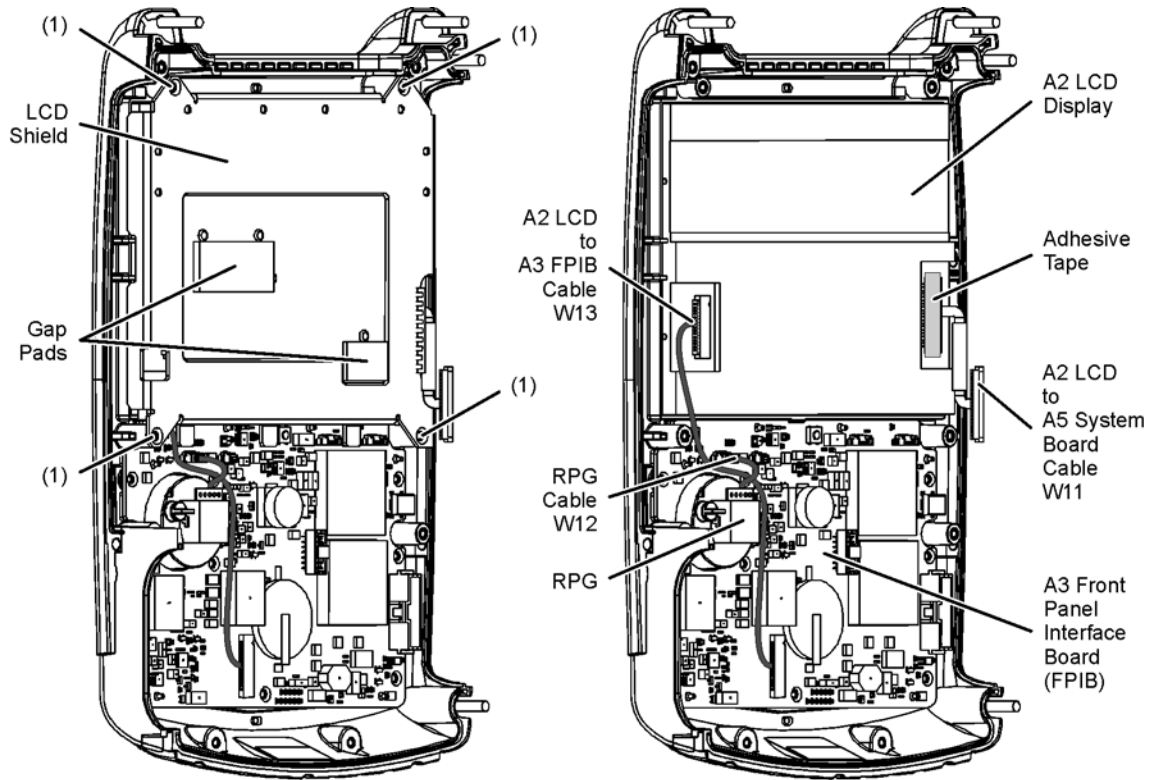

**The LCD shield was removed for the photo below.
CN3 and CN4 provide power for the LCD backlight.**

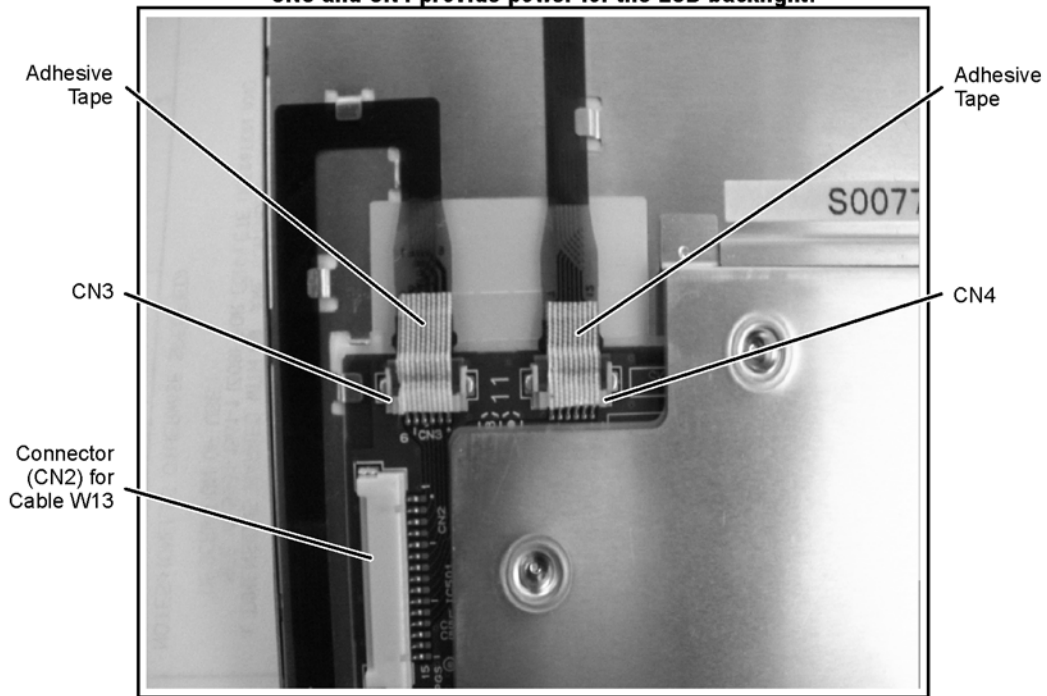

n9912_90003_715

Replacing the A3 Front Panel Interface Board (FPIB)

NOTE

The A3 front panel interface board contains a Lithium-ion battery. Refer to [“Battery Disposal” on page 1-8](#) for important instructions on disposing of this printed circuit board with the battery attached. If necessary, the battery can be removed from the printed circuit board and disposed of separately.

1. Perform the steps under [“Pre-replacement Procedure” on page 7-21](#).
2. Remove the four screws (item 2) that secure the LCD shield and remove the LCD shield. Discard the four screws, new ones are provided in the [Repair and Re-assembly Kit](#). Be careful. The A2 LCD display is now loose and will fall out of the front case if the case is tipped.
3. Disconnect the RPG cable, W12, at the A3 FPIB connector as indicated.
4. Disconnect the A2 LCD to FPIB cable, W113, at the A3 FPIB connector as indicated.
5. Remove the nine screws (item 3) that secure the A3 FPIB to the front case.
6. Push the nine rubber “nubs” through the A3 FPIB to release the A1 keypad. The A1 keypad is permanently attached to the front case and must remain.
7. Position the new A3 FPIB in the front case over the A1 keypad and, using needle-nose pliers, pull the nine rubber “nubs” on the A1 keypad through the holes in the A3 FPIB. Make sure that all nine of the rubber “nubs” are fully extended on the back side of the A3 FPIB.
8. Secure the A3 FPIB to the front case with nine new screws (item 3) provided in the [Repair and Re-assembly Kit](#).
9. Re-connect the A2 LCD to FPIB cable, W13, to the A3 FPIB connector as indicated. Route the cable as shown.
10. Re-connect the RPG cable, W12, to the A3 FPIB connector as indicated, with the A2 LCD to A3 FPIB cable, W13, passing beneath it as shown. Bend the RPG cable toward the right side as shown.
11. Place the LCD shield back in position on the A2 LCD. Make sure that the A2 LCD to A3 FPIB cable, W13, is routed between, not under, the shield gaskets.
12. Secure the shield with four new screws (item 2) provided in the [Repair and Re-assembly Kit](#).
13. Perform the steps under [“Post-replacement Procedure” on page 7-28](#).

Figure 7-16 Replacing the A3 Front Panel Interface Board

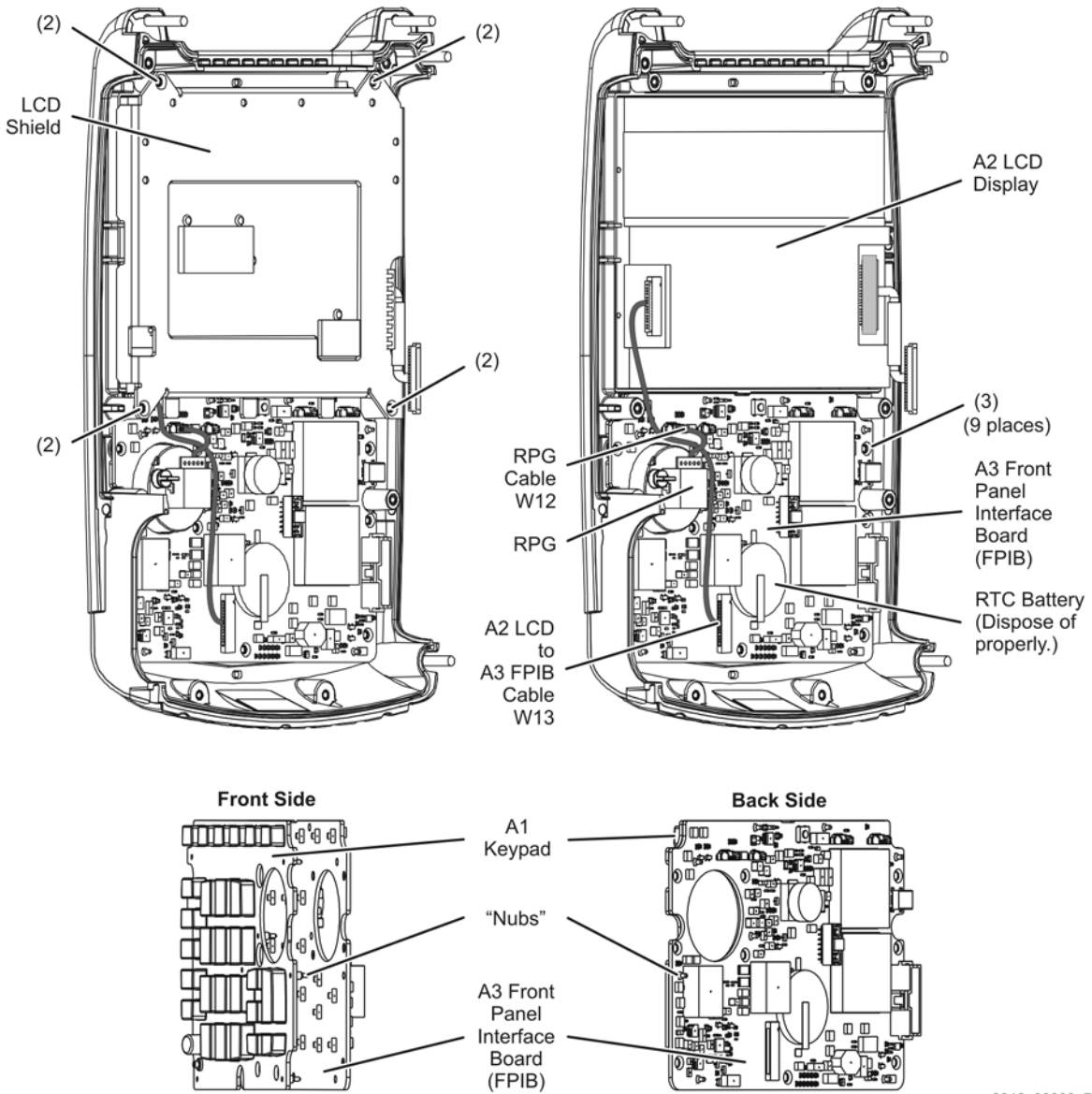

n9912_90003_716

Replacing the Real Time Clock (RTC) Battery Located on the A3 Front Panel Interface Board (FPIB)

NOTE

The RTC battery is a Lithium-ion battery and must be disposed of properly. Refer to **"Battery Disposal"** on page 1-8 for important instructions on disposing of this battery.

NOTE

A soldering tool is required for this procedure.

1. Perform the steps under **"Pre-replacement Procedure"** on page 7-21.
2. Unsolder the RTC battery from the A3 FPIB.
3. Insert and solder the new RTC battery into place.
4. Perform the steps under **"Post-replacement Procedure"** on page 7-28.

Figure 7-17

Replacing the RTC Battery

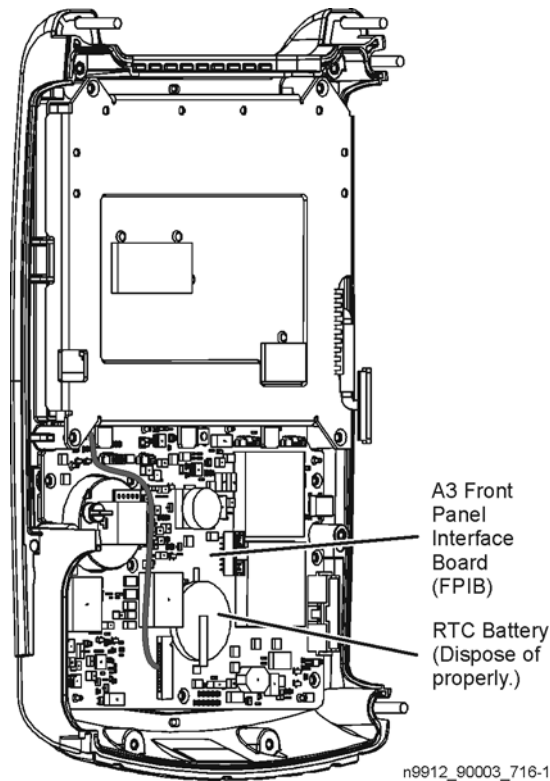

Post-replacement Procedure

1. Reinstall the measurement group assemblies (RF top panel, A4 RF board, A5 system board, and A6 SOM board) as one unit with the I/O panel attached. Refer to **"Removing and Replacing the Measurement Group Assemblies"** on page 7-29.
2. Combine the front and rear cases. Refer to **"Combining the Front and Rear Cases"** on page 7-17.

Removing and Replacing the Measurement Group Assemblies

Tools Required

- T-8 TORX driver (set to 6 in-lb)
- T-10 TORX driver (set to 9 in-lb)
- 5/16-inch open-end torque wrench (set to 10 in-lb)
- 9/16-inch open-end torque wrench (set to 21 in-lb)
- **Repair and Re-assembly Kit**. Refer to **“Miscellaneous Parts” on page 6-12**.

WARNING

Before beginning any repair, remove the battery and disconnect external power.

NOTE

If the FieldFox serial number is below xx4910xxxx, and either the A5 System board or the RF assembly is being replaced, see Keysight Service Note N9912A-03. It may be necessary to replace both assemblies at the same time.

Removing All Measurement Group Assemblies as One Unit

- a. Separate the front and rear cases. Refer to **“Separating the Front and Rear Cases” on page 7-9**.
3. Disconnect the A5 system board to A3 FPIB cable, W14, at the A3 FPIB connector. If replacing this cable, disconnect both ends.
4. Lift the measurement group assemblies out of the front case and position them to the side of the front case as shown.
5. Disconnect the A2 LCD to A5 system board cable, W11, at the A5 system board connector. It is necessary to first remove the adhesive tape that is over the connector. To replace this cable, refer to **“Replacing the A2 LCD, the LCD Shield, and LCD Cables” on page 7-22**.
6. The measurement group assemblies are now completely separated from the analyzer.
7. To remove the I/O panel, refer to **“Replacing the I/O Side Panel, Doors, and Gasket” on page 7-14**.

Figure 7-18 Removing All Measurement Group Assemblies as One Unit

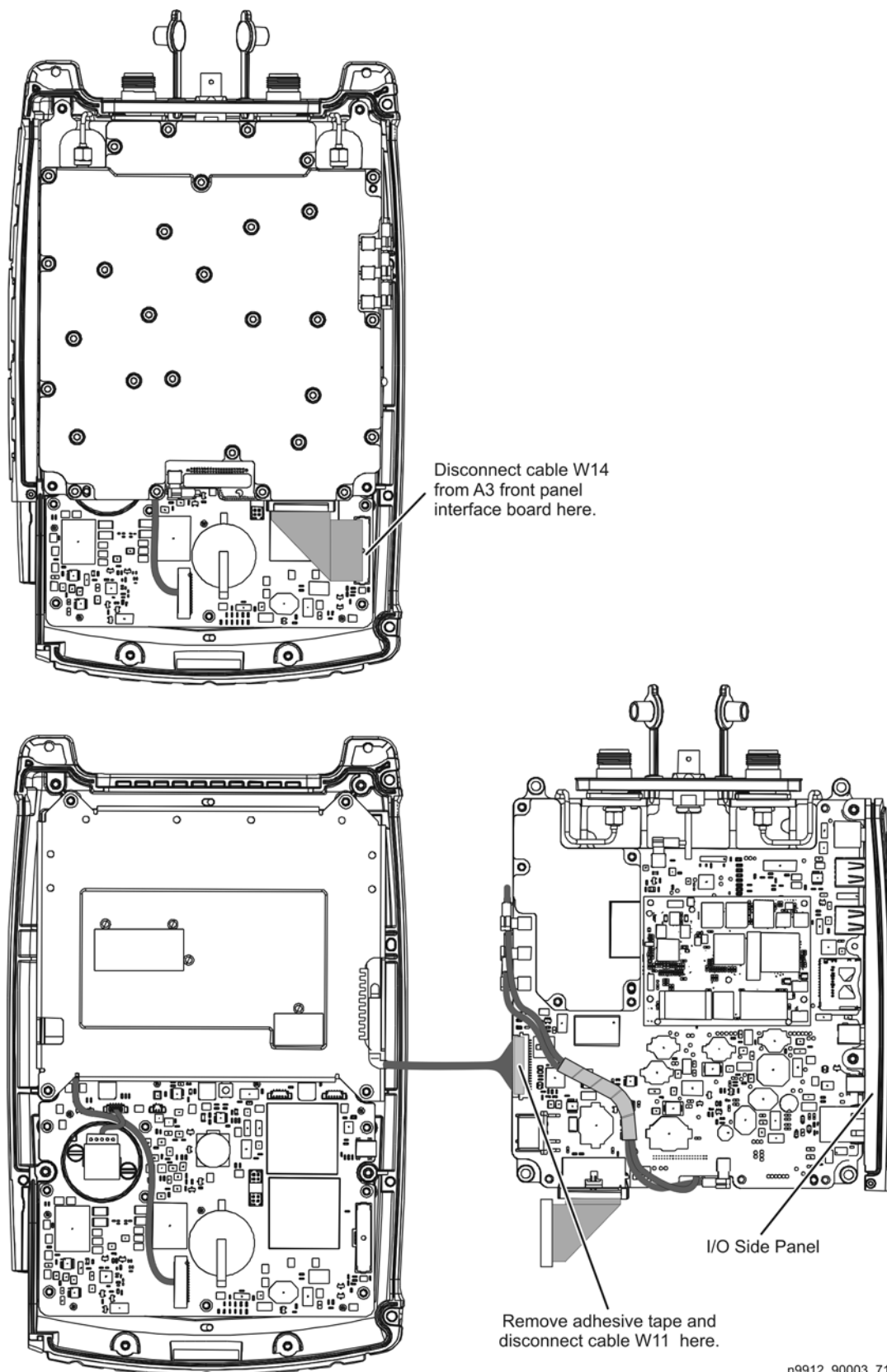

n9912_90003_717

Replacing the RF Top Panel Assembly

1. Separate the front and rear cases. Refer to [“Separating the Front and Rear Cases” on page 7-9.](#)
2. Remove all measurement group assemblies as one unit. Refer to [“Removing All Measurement Group Assemblies as One Unit” on page 7-29.](#)
3. Unplug the two connector plugs (tethered caps) from the type-N RF connectors.
4. Disconnect cable W3.
5. Remove the six screws (item 1) and lift the RF top panel over the type-N RF connectors.
6. Position the new RF top panel over the type-N RF connectors and loosely reinstall the six screws (item 1). Do not tighten these screws at this time; they will be tightened after the front and rear cases have been combined.
7. Connect cable W3 to the A5 system board connector. There should be an audible click when the connector is fully in place.
8. Position (tuck) the cable W3 into the cavity above the A5 system board to avoid interference with nearby parts.
9. Plug the two connector plugs (tethered caps) back into the type-N RF connectors to protect the connectors.
10. Perform the steps under [“Post-replacement Procedure” on page 7-43.](#)

Figure 7-19

Replacing the RF Top Panel Assembly

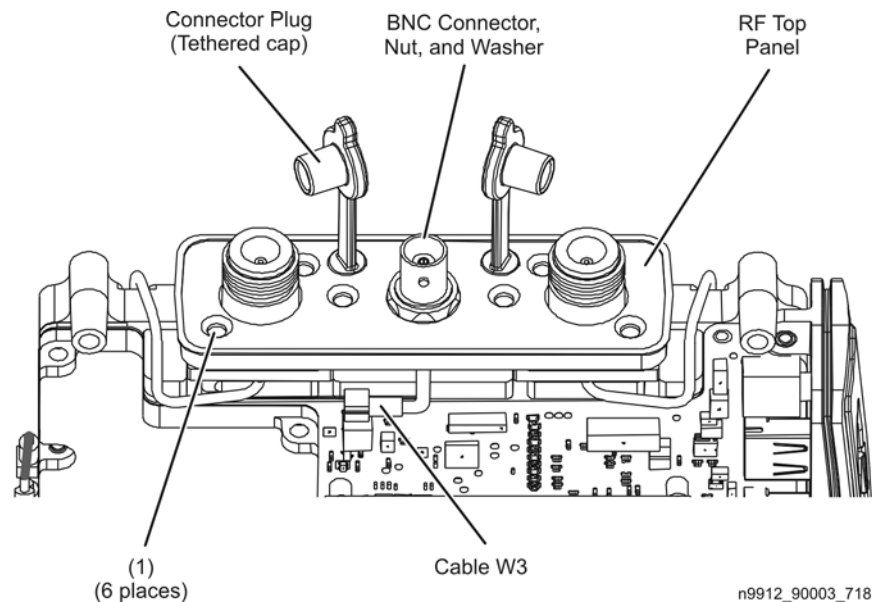

Replacing the Type-N RF Connectors and RF Cables

1. Separate the front and rear cases. See ["Separating the Front and Rear Cases" on page 7-9.](#)
2. Remove all measurement group assemblies as one unit. Refer to ["Removing All Measurement Group Assemblies as One Unit" on page 7-29.](#)
3. Remove the RF top assembly. Refer to ["Replacing the RF Top Panel Assembly" on page 7-31.](#)
4. Disconnect the cable connector nut on cable W1 or W2, depending on which connector or cable is being replaced. Do not attempt to remove the cable, just release the connector nut.
5. Remove the two screws (item 2) from the type-N RF connector to be replaced.
6. Lift the type-N RF connector upwards and out of the RF bottom shield.
7. The RF input cable can now be replaced by disconnecting the other end of the cable and removing it. When installing the new cable, do not tighten either of the cable connector nuts until both of them have been installed finger tight.
8. Remove the RFI O-ring.
9. Remove the old insulator and install a new one.
10. Position the new type-N RF connector in the RF bottom shield, making sure that it aligns with the cable connector underneath. Loosely install the cable connector nut.
11. Install a new RFI O-ring over the new type-N RF connector in the position shown.
12. Loosely reinstall the two screws (item 2). Note the location for these two screws in the illustration. To ensure proper alignment, install two additional screws, finger tight, in the two empty holes in the type-N RF connector, then tighten the two screws that secure the connector. Remove the two alignment screws.
13. Tighten the cable connector nut(s) on cable W1 or W2.
14. Perform the steps under ["Post-replacement Procedure" on page 7-43.](#)

Figure 7-20

Replacing the Type-N RF Connectors and RF Cables

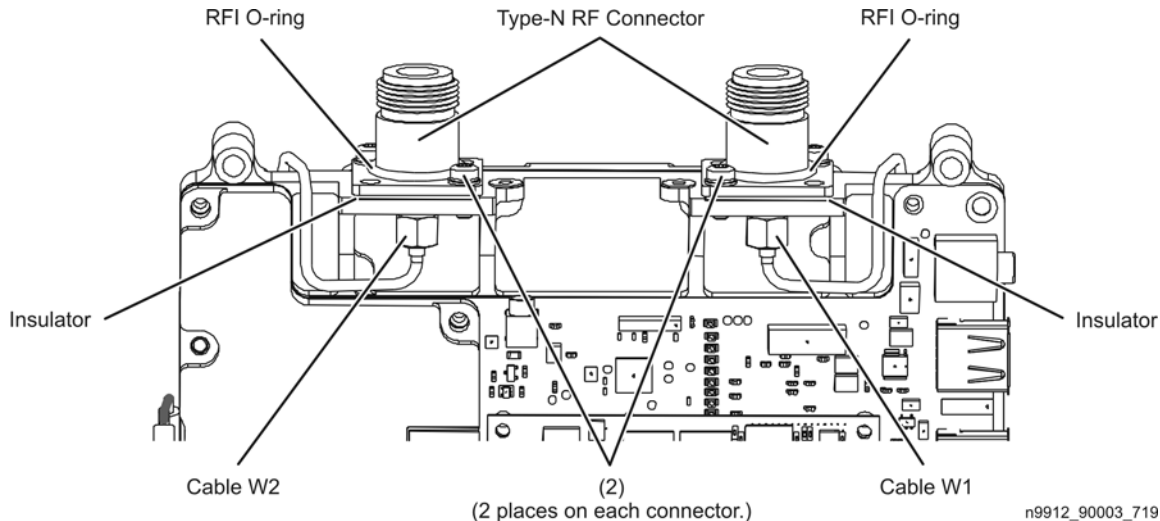

Replacing the A6 SOM Board and Flexible RF Cables

1. Separate the front and rear cases. Refer to [“Separating the Front and Rear Cases” on page 7-9](#).
2. Remove all measurement group assemblies as one unit. Refer to [“Removing All Measurement Group Assemblies as One Unit” on page 7-29](#).
3. To replace the A6 SOM board:
 - a. Remove the four screws (item 3) that secure the A6 SOM board. Discard these screws; new ones are provided in the [Repair and Re-assembly Kit](#).
 - b. Unplug the A6 SOM board from the A5 system board.
 - c. Plug the new A6 SOM board into the A5 system board.
 - d. Install four new screws (item 3) from the [Repair and Re-assembly Kit](#) and tighten them in the torque sequence indicated by the circled numbers (1234) in the illustration.
4. To replace the flexible RF cables:
 - a. To aid in reinstallation, note the connector to which each cable end is connected before disconnecting the cable. Refer to [Figure 5-1 on page 5-3](#) for an electrical diagram of each cable connection.
 - b. Cables W4 and W6 are provided as an assembly. When replacing this coax cable assembly:
 1. Make sure the cable connectors are positioned as shown and that the cable assembly is routed as shown. Cable W6 is the one with a red mark on each connector.

2. Ensure that there is no slack in the cables at the top connections as indicated.
 3. Make sure that the cable assembly does not touch the TCXO chip on the A5 system board.
 4. Clip cable W6 into each of the cable clamps on the A5 system board. Cable W6 is the one with a red mark on each connector.
- c. To replace cable W5 or W7:
1. Disconnect the appropriate cable and install the new cable being sure to position it as shown.
5. To remove the I/O panel, refer to ["Replacing the I/O Side Panel, Doors, and Gasket"](#) on page 7-14.
 6. Perform the steps under ["Post-replacement Procedure"](#) on page 7-43.

Figure 7-21 Replacing the A6 SOM Board and Flexible RF Cables

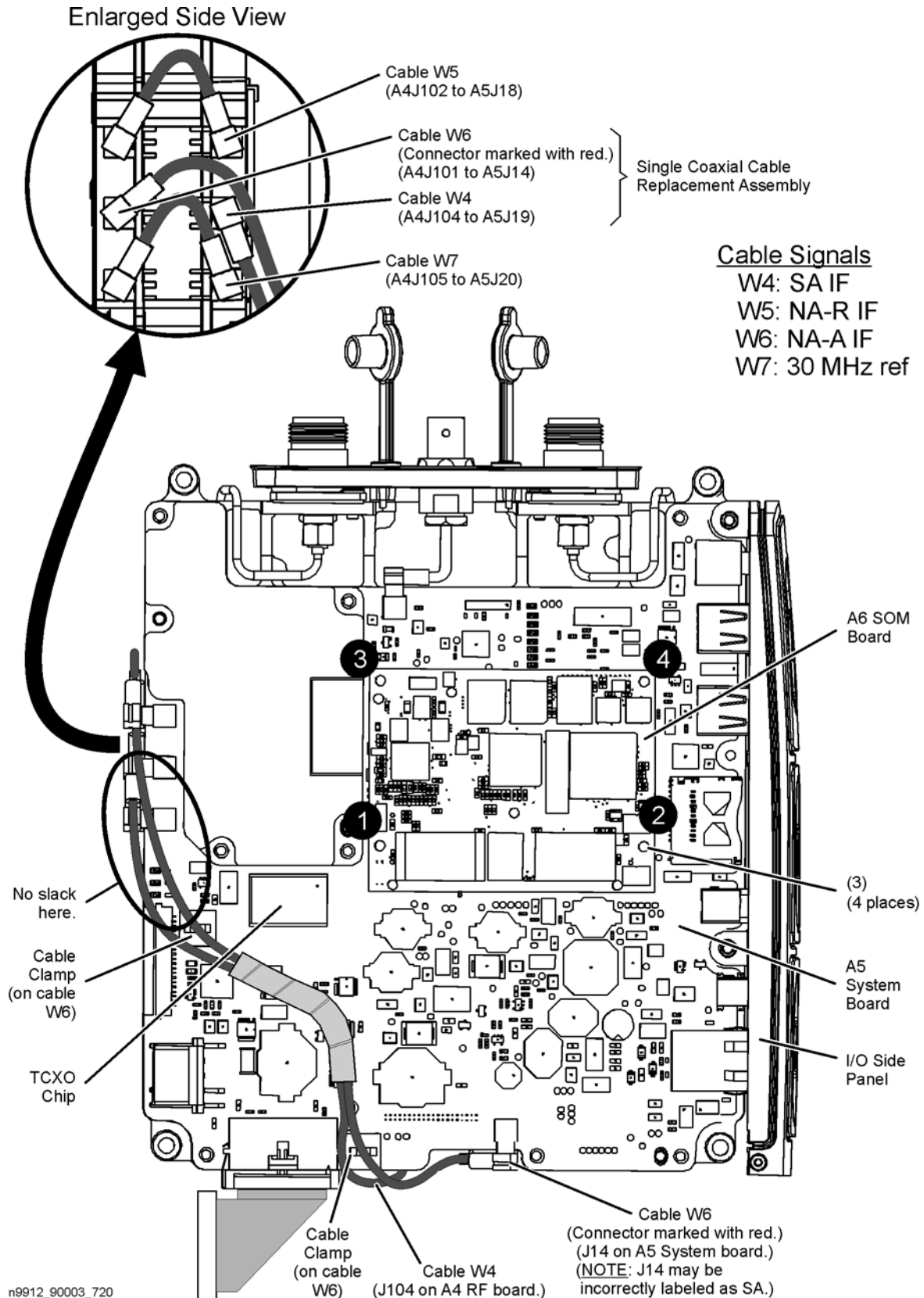

Replacing the A5 System Board

1. Separate the front and rear cases. See ["Separating the Front and Rear Cases" on page 7-9.](#)
2. Remove all measurement group assemblies as one unit. Refer to ["Removing All Measurement Group Assemblies as One Unit" on page 7-29.](#)
3. Remove the I/O side panel. Refer to ["Replacing the I/O Side Panel, Doors, and Gasket" on page 7-14.](#)
4. Remove the A6 SOM board and flexible RF cables. Refer to ["Replacing the A6 SOM Board and Flexible RF Cables" on page 7-33.](#) Refer also to Enlarged Side View in illustration. Note which cable is connected to which pc board connector to aid in reinstallation.
5. Disconnect cable W3 from the A5 system board.
6. Remove four screws (item 4) from the system board shield and remove the shield. Discard the screws, new ones are provided in the [Repair and Re-assembly Kit.](#)
7. Remove six screws (item 5) from the A5 system board, lift it up from the RF bottom shield, and unplug it from the A4 RF board connector. Discard the screws, new ones are provided in the [Repair and Re-assembly Kit.](#)
8. Remove the waffle gasket from the RF bottom shield and discard it. A new gasket is provided in the [Repair and Re-assembly Kit.](#)
9. Manipulate the new waffle gasket by hand to eliminate curling and install it on the RF bottom shield using the three dowel pins for alignment. It is not necessary that the gasket be completely flat, just enough to remain in position while installing the new A5 system board.
10. Plug in the new A5 system board to the A4 RF board, over the new gasket, and aligned with the three dowel pins in the RF bottom shield.
11. Position a new waffle gasket, from the [Repair and Re-assembly Kit,](#) for the system board top shield, on the A5 system board using the two dowel pins for alignment. Manipulate this gasket by hand to flatten it if necessary.
12. Reinstall the system board top shield over the gasket and aligned with the dowel pins.
13. Hand-tighten four new screws (item 4) to secure the system board top shield and six new screws (item 5) to secure the A5 system board to the RF bottom shield.
14. Torque these ten screws in the sequence shown by the circled numbers (①⑦⑩). Repeat this torque sequence one additional time.
15. Reinstall the A6 SOM board and reinstall or reconnect all coax cables that were removed or disconnected previously. Refer to ["Replacing the A6 SOM Board and Flexible RF Cables" on page 7-33.](#)

16. Remove the system board to FPIB cable from the old A5 system board and install it on the new board.
17. Reinstall the I/O side panel. Refer to ["Replacing the I/O Side Panel, Doors, and Gasket"](#) on page 7-14.
18. Perform the steps under ["Post-replacement Procedure"](#) on page 7-43.

Replacing the RF Assembly Including the A4 RF Board

1. Separate the front and rear cases. Refer to [“Separating the Front and Rear Cases” on page 7-9.](#)
2. Remove all measurement group assemblies as one unit. Refer to [“Removing All Measurement Group Assemblies as One Unit” on page 7-29.](#)
3. Disconnect the flexible RF cables from the A4 RF board; it is not necessary to disconnect the cables from the A5 system board. Refer to [“Replacing the A6 SOM Board and Flexible RF Cables” on page 7-33.](#)
4. Remove the A5 system board. Refer to [“Replacing the A5 System Board” on page 7-36.](#)
5. Remove the BNC connector, nut, and washer from the old RF assembly and install them in the new RF assembly. Note: Cable W3 includes the BNC connector.
6. Reinstall the A5 system board onto the new RF assembly. Refer to [“Replacing the A5 System Board” on page 7-36.](#)
7. Re-connect the flexible RF cables to the A4 RF board. Refer to [“Replacing the A6 SOM Board and Flexible RF Cables” on page 7-33.](#)
8. Perform the steps under [“Post-replacement Procedure” on page 7-43.](#)

Figure 7-23

Replacing the RF Assembly Including the A4 RF Board

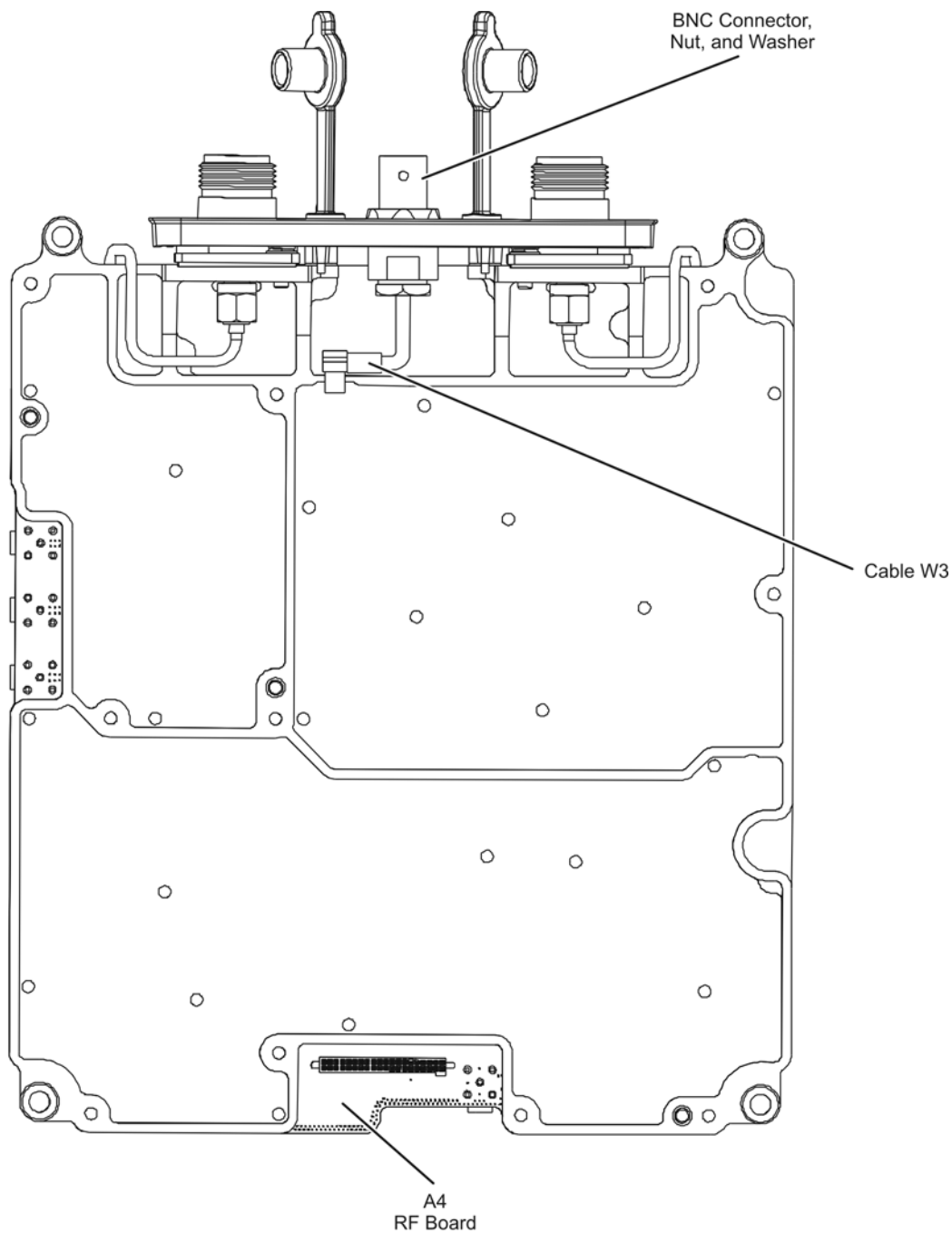

View of the RF Assembly After Removing the A5 System Board.

n9912_90003_722

Reinstalling All Measurement Group Assemblies as One Unit

1. Reinstall the I/O side panel, if needed. Refer to [“Replacing the I/O Side Panel, Doors, and Gasket”](#) on page 7-14.
2. Position the measurement group assemblies to the side of the front case as shown in [Figure 7-18 on page 7-30](#). Refer to [“Removing All Measurement Group Assemblies as One Unit”](#) on page 7-29.
3. Reconnect the LCD to system board cable at the system board connector and place a strip of adhesive tape over the connector to secure it. This strip of adhesive tape is provided in the [Repair and Re-assembly Kit](#). If necessary, refer to [“Replacing the A2 LCD, the LCD Shield, and LCD Cables”](#) on page 7-22.
4. Position the measurement group assemblies on top of the front case and align the I/O side panel in the groove in the front case being careful not to damage the gasket.
5. Position (tuck) the LCD to system board cable in between the LCD shield and the A5 system board so that it will not interfere with the cases when they are combined.
6. Reconnect the system board to front panel interface board cable at the front panel interface board connector as shown.

Figure 7-24 Replacing All Measurement Group Assemblies as One Unit

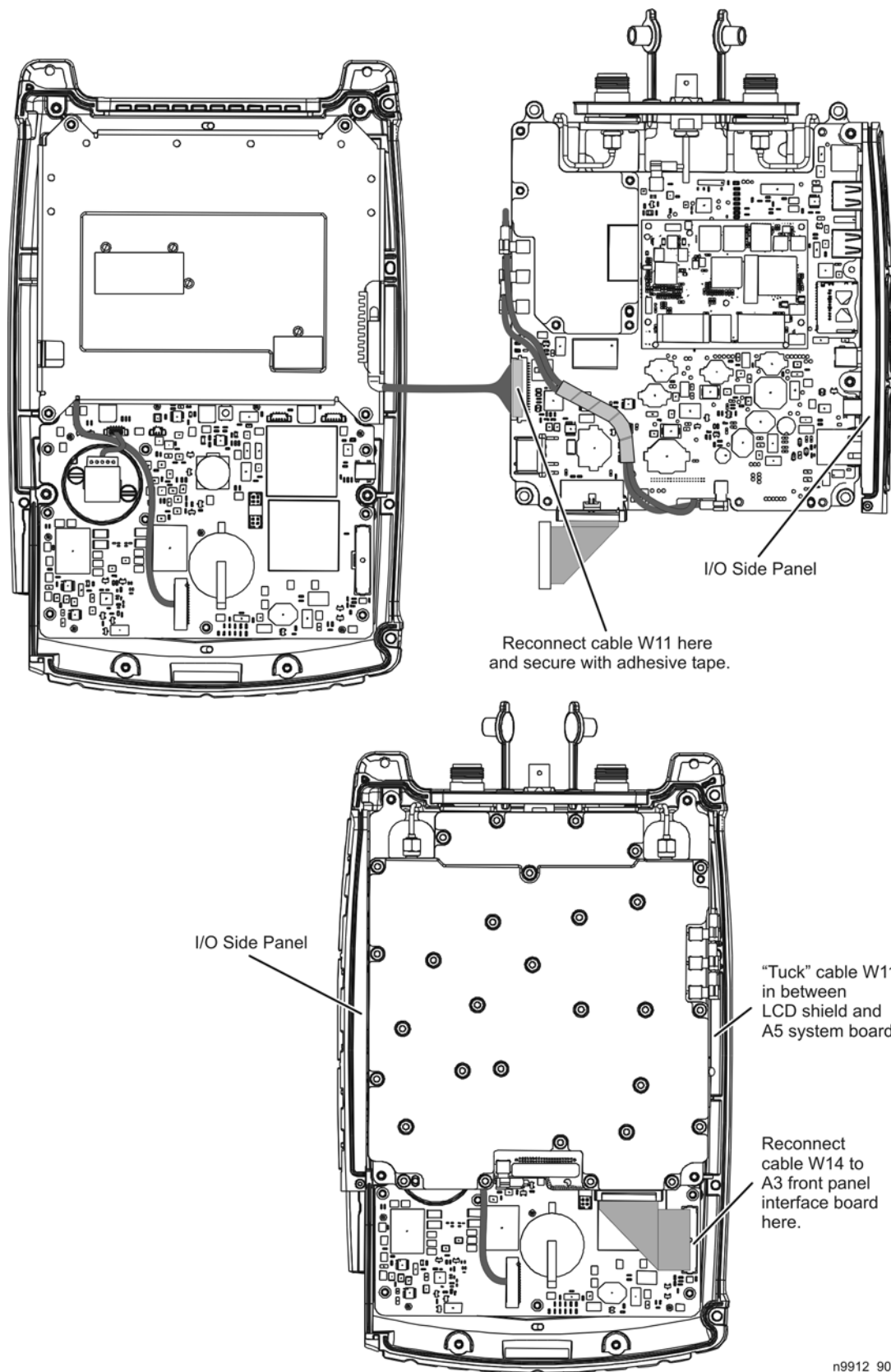

Post-replacement Procedure

1. Reinstall the measurement group assemblies into the front case. Refer to ["Reinstalling All Measurement Group Assemblies as One Unit" on page 7-41.](#)
2. Combine the front and rear cases. Refer to ["Combining the Front and Rear Cases" on page 7-17.](#)

Post-Repair Procedures

After the replacement of an assembly, you must perform the service procedures in the order listed in [Table 7-2](#).

Procedures referenced in this table are located in [Chapter 3, "Tests and Adjustments,"](#) unless specified otherwise.

Table 7-2 Related Service Procedures

Replaced Assembly	Adjustments, etc.	TME Tests or Other Procedures
Main battery	None needed.	None needed.
RPG	None needed.	Manual check of RPG operation.*
RF OUT connector or associated cable (W1) replaced or disturbed.	None needed.	Error Terms test.
RF IN connector or associated cable (W2) replaced or disturbed.	None needed.	Station Calibration for tests. Absolute Amplitude Accuracy Test. Frequency Response Preamp Off test. Frequency Response Preamp On test.
Front case (including A1 keypad)	None needed.	Manual check of keyboard.*
A2 LCD	None needed.	Manual check of LCD.*
A3 front panel interface board	None needed.	Manual check of keyboard.* Check for even brightness in LCD backlight.* Check sound.*
A4 RF board	All TME based adjustments that apply to the installed option configuration.	All TME based tests that apply to the installed option configuration.
A5 system board	First, load the instrument serial number into the A5 system board.* All TME based adjustments that apply to the installed option configuration.	All TME based tests that apply to the installed option configuration.
A6 SOM board	Install firmware from SD card.* Re-install options.* All TME based adjustments that apply to the installed option configuration.	Compare serial numbers.* All tests that apply to the installed option configuration.

* Refer to the following manual checks and procedures for details.

Manual Checks and Procedures

Manual Check of Keyboard

Check that each key works properly. Check that the keyboard backlight LEDs come on when a key is pressed.

Manual Check of LCD

Press Service (7) > Display, then use Display Colors and Brightness keys to exercise the display. Check for even brightness in the LCD backlight.

Manual Check of RPG Operation

Activate a marker and use the RPG to move the marker.

Load Instrument Serial Number into the A5 System Board

Instructions for this process may be accessed via the "Load instrument serial number into System Board" link at keysight.com/find/fieldfox2.

Install Firmware from SD Card

A specially configured SD card must be used when the flash memory on the A6 SOM board is new or when the A6 SOM board memory has become corrupted.

Instructions for creating and using the SD card are available at the "SD card for installing firmware" link at keysight.com/find/fieldfox2.

Compare Serial Numbers

Compare the serial number stored in the instrument memory with the serial number tag on the back of the instrument.

To access the stored serial number, press:

System (7) > Service Diagnostics > System Information

Check Sound

Attempt to set a frequency to a value of "." (decimal point); a double beep should occur.

Re-Install Options

See the "[Service Related User Operations](#)" section of [Chapter 8](#) for information on re-installing options.

Processor Upgrade Procedures

N9910HU-500 Processor Upgrade Procedures

1. Separate the front and rear cases. See [“Separating the Front and Rear Cases” on page 7-9.](#)
2. Remove all measurement group assemblies as one unit. Refer to [“Removing All Measurement Group Assemblies as One Unit” on page 7-29.](#)
3. Remove the I/O side panel. Refer to [“Replacing the I/O Side Panel, Doors, and Gasket” on page 7-14.](#)
4. Remove the A6 SOM board and flexible RF cables. Refer to [“Replacing the A6 SOM Board and Flexible RF Cables” on page 7-33.](#) Refer also to Enlarged Side View in illustration. Note which cable is connected to which pc board connector to aid in reinstallation.
5. Disconnect cable W3 from the A5 system board.
6. Remove four screws (item 4) from the system board shield and remove the shield. Discard the screws, new ones are provided in the [Repair and Re-assembly Kit.](#)
7. Remove six screws (item 5) from the A5 system board, lift it up from the RF bottom shield, and unplug it from the A4 RF board connector. Discard the screws, new ones are provided in the [Repair and Re-assembly Kit.](#)
8. Remove the waffle gasket from the RF bottom shield and discard it. A new gasket is provided in the [Repair and Re-assembly Kit.](#)
9. Manipulate the new waffle gasket by hand to eliminate curling and install it on the RF bottom shield using the three dowel pins for alignment. It is not necessary that the gasket be completely flat, just enough to remain in position while installing the new A5 system board.
10. Plug in the new A5 system board to the A4 RF board, over the new gasket, and aligned with the three dowel pins in the RF bottom shield.
11. Position a new waffle gasket, from the [Repair and Re-assembly Kit,](#) for the system board top shield, on the A5 system board using the two dowel pins for alignment. Manipulate this gasket by hand to flatten it if necessary.
12. Reinstall the system board top shield over the gasket and aligned with the dowel pins.
13. Hand-tighten four new screws (item 4) to secure the system board top shield and six new screws (item 5) to secure the A5 system board to the RF bottom shield.
14. Torque these ten screws in the sequence shown by the circled numbers (①⑦⑩). Repeat this torque sequence one additional time.

15. Install the new CPU2 SOM board and reinstall or reconnect all coax cables that were removed or disconnected previously. Refer to [“Replacing the A6 SOM Board and Flexible RF Cables”](#) on page 7-33.
16. Remove the system board to FPIB cable from the old A5 system board and install it on the new board.
17. Install new gap pads on the LCD shield in the location shown. Refer to [Figure 7-25](#) for the placement of gap pads. Remove old gap pad, only remain N9912-20038 gap pad.
18. Install the new I/O side panel. Refer to [“Replacing the I/O Side Panel, Doors, and Gasket”](#) on page 7-14.
19. Perform the steps under [“Post-replacement Procedure”](#) on page 7-43.
20. Replace the old nameplate with new nameplate. Refer to [Figure 7-10](#) on page 7-16. Choose the appropriate model number nameplate overlay for your analyzer, remove the protective baking to expose the adhesive, and adhere it in the location shown. Refer to [Figure 7-26](#) for the new nameplate with red Keysight logo.
21. Proceed [“Post-Repair Procedures”](#) on page 7-44 . Download and install the latest Firmware for the CPU2 from [FieldFox Series Firmware Updates](#).

Figure 7-25

Placement of gap pads

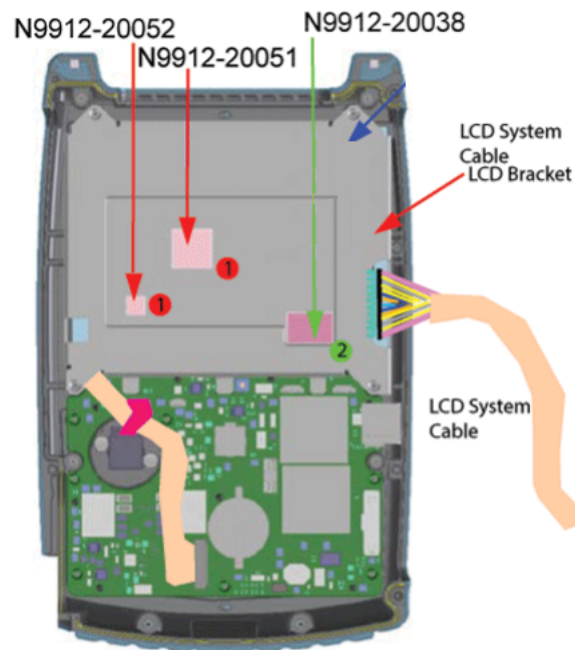

Figure 7-26

New Keysight Nameplate



Repair and Replacement Procedures
Processor Upgrade Procedures

8 General Purpose Maintenance and Service Procedures

Information in This Chapter

Chapter Eight at-a-Glance

Section Title	Summary of Content	Start Page
Service Related User Operations	How to: <ul style="list-style-type: none"> – view options currently installed on your analyzer – view the current firmware revision – view the error log – view temperature readings – erase user data 	page 8-2
Options	How to: <ul style="list-style-type: none"> – view the currently installed options – re-install options after repair 	page 8-4
Firmware Upgrades	How to: <ul style="list-style-type: none"> – check your analyzer's current firmware revision – where to locate additional information about firmware upgrades 	page 8-6
Miscellaneous Service and Maintenance	Information about: <ul style="list-style-type: none"> – cleaning the display – battery maintenance 	page 8-7

Service Related User Operations

To View Currently Installed Options

- Press System(7).
- Press System Configuration.
- Press Options.
- Press Show Options.

A list of the currently installed options is displayed.

To View the Current Firmware Revision, Etc.

- Press System(7).
- Press Service Diagnostics.
- Press System Information.

The System Information screen includes the following information:

- Model Number = instrument model number
- Serial Number = instrument serial number
- Firmware Release = version of installed firmware
- Network Identity = computer name and current IP address
- RF Serial Number = serial number of RF PCA
- SB Serial Number = serial number of System Board PCA
- FP Serial Number = serial number of Front Panel PCA
- UserData Erased = the most recent date and time User Data Erase performed

To View the Error Log

- Press System(7).
- Press Service Diagnostics.
- Press Error Log.

See the **"Firmware Related Information"** section of **Chapter 5** for details on the error log.

To View Temperature Readings

- Press System(7).
- Press Service Diagnostics.

General Purpose Maintenance and Service Procedures
Service Related User Operations

- Press Internal Temperatures.

See the **“Temperature Related Information”** section of **Chapter 5** for details.

Erase User Data Utility

- Press System(7).
- Press Service Diagnostics.
- Press Advanced.
- Press Erase User Data.
- Press Confirm Erase.

The UserData memory portion is erased, then the instrument restarts. See the **“Firmware Related Information”** section of **Chapter 5** for details on the Erase User Data utility.

Options

Installed options determine the functionality of the analyzer. There is a license associated with each option. Every instrument has at least one option installed, "104", or "106". This option determines the maximum frequency of the instrument. Additional options enable additional modes or other functionality.

Note that the maximum frequency of the instrument may not be "upgraded". Option 104 or 106 is installed in the factory and may not be changed in the field.

To View Currently Installed Options

- Press System(7).
- Press System Configuration.
- Press Options.
- Press Show Options.

A list of the currently installed options is displayed.

Re-Installing Options

If an instrument loses all of its options (i.e. it reports or "shows" no options), the only functionality available will be CAT up to 4 GHz.

When the A6 SOM board is replaced, it is necessary to re-load the license files because the license and option information is stored on the A6 SOM board.

Process for obtaining and re-installing options:

1. Send an email to ctd-soco_support@keysight.com with the following information.
 - Indicate that you need previously issued license for a FieldFox repair.
 - Model number and serial number of the instrument.
 - Maximum frequency of the instrument from the label above the display.
 - A list of options from the serial number label on the back of the instrument.
 - A brief description of why options need to be re-installed. This information will help Keysight identify recurring problems that may need special attention.
2. Within two working days, you will receive an email response with a license file attached.

3. Copy the license file to the root of a USB flash drive. Follow the appropriate instructions in the N9912A Upgrade Installation Instructions (N9912-90005) to install the licenses. These instructions are available by searching for "N9912-90005" on the Web at www.keysight.com.

Additional Information About Options

For information on acquiring additional options, go to www.keysight.com/find/fieldfox2 and follow the "Upgrades available for FieldFox N9912A" link. There is an installation note associated with each option upgrade that provides detailed instructions. Some combinations of options are not valid; see the web information for details.

Firmware Upgrades

To Check the Current Firmware Revision

- Press System(7).
- Press Service Diagnostics.
- Press System Information.

The current firmware version is indicated on the “Firmware Release” line.

For information on upgrading FieldFox firmware, go to www.keysight.com/find/fieldfox2.

If the firmware upgrade process is interrupted, memory contents in the instrument may become corrupted. If a problem is suspected, consider doing a fresh installation of the firmware. Follow the process under “**Install Firmware from SD Card**” near the end of **Chapter 7**.

See the “**Firmware Related Information**” section of **Chapter 5** for details on what happens during the firmware update process.

Miscellaneous Service and Maintenance

Cleaning the Display

Materials: Use a soft, lint-free cloth. Use a solution with 99.5% IPA (isopropyl alcohol) or a high quality window cleaning solution.

Technique: Do not rub back and forth with a polishing motion. Use a single swipe from the soiled location to the nearest edge of the display.

Battery Maintenance

See the "Working with the Lithium-Ion Battery" section of the FieldFox User's Guide for information on the removable battery. In particular, see "Built-In Battery Gauge" and "Reconditioning the Battery".

General Purpose Maintenance and Service Procedures
Miscellaneous Service and Maintenance

Index

A

- A1 keypad
 - illustrated, 6-4
 - part number, 6-4
 - removal and replacement, 7-7
- A2 LCD
 - illustrated, 6-4
 - operation, 5-5
 - part number, 6-4
 - removal and replacement, 7-21
- A3 front panel interface board
 - illustrated, 6-4
 - operation, 5-4
 - part number, 6-4
 - removal and replacement, 7-21
- A4 RF board
 - operation, 5-6
- A5 system board
 - operation, 5-10
 - removal and replacement, 7-29
- A6 SOM board
 - operation, 5-15
 - removal and replacement, 7-29
- adjustments, 3-9
- analyzer
 - miscellaneous replaceable parts
 - part numbers, 6-12
 - options, 2-3
 - system block diagram, 5-3
 - warmup time, 3-3
- ANSI Z540 standards
 - compliant calibration, Option A6J, 2-4
- assemblies
 - replacement
 - cautions about, 7-4
 - list of procedures, 7-5
 - sequence, 6-3, 7-4
 - warnings about, 7-4

B

- battery
 - cable
 - removal and replacement, 7-7
 - charging management, 5-18
 - information screen, 5-18
 - operation, 5-15, 5-18
 - temperature, 5-26
 - battery disposal, 1-8
 - battery, main
 - removal and replacement, 7-6
 - battery, RTC
 - removal and replacement, 7-21
 - before applying power, 1-3
- ### C
- calibration
 - ANSI Z540 standards
 - compliant, Option A6J, 2-4
 - commercial, Option UK6, 2-4
 - in CAT and NA modes, 5-27
 - ISO 17025 standards
 - compliant, Option 1A7, 2-4
 - one port, 5-27
 - options available, 2-4
 - QuickCal, 5-27
 - two port, 5-27
 - types, 5-27
 - care of connectors, 3-3
 - case group
 - removal and replacement procedure, 7-7
 - cases
 - removal and replacement, 7-7
 - caution, 1-2
 - CE mark, 1-7
 - check
 - operational, 3-7
 - checklist
 - before return to customer, 3-6
 - checks and procedures

- manual, 7-44
- commercial calibration
 - Option UK6, 2-4
- compare
 - instrument serial numbers, 7-44
- connector
 - care
 - principles of, 3-3
 - quick reference, 3-3
- connectors
 - care of, 3-3
- contacting Keysight, 2-5
- CPU board
 - operation, 5-15
 - removal and replacement, 7-29
- CSA mark, 1-7

D

- display
 - illustrated, 6-4
 - operation, 5-5
 - parts list, 6-4
 - removal and replacement, 7-21
- documentation
 - part numbers, 6-13

E

- earth ground, 1-3
- electrostatic discharge, *See* ESD
- equipment
 - for service, 3-5
- erase user data utility, 5-29
- error log, 5-29
- ESD
 - protection, 1-5, 3-3, 4-2, 7-3
 - supplies
 - part numbers, 6-13

F

firmware

- check current revision of, 8-6
- erase user data utility, 5-29
- error log, 5-29
- general description, 5-29
- install from SD card, 7-44
- operational files, 5-29
- upgrades, 5-29
- upgrading, 8-6
- user accessible files, 5-29

front panel

- replaceable parts
 - illustrated, 6-4
 - part numbers, 6-4

front panel group

- operation, 5-4
- troubleshooting, 4-7

front panel group assemblies

- removal and replacement, 7-21

front panel interface board

- illustrated, 6-4
- operation, 5-4
- part number, 6-4
- removal and replacement, 7-21

functional groups, 5-2

G

general safety

- considerations, 1-3
- ground, safety earth, 1-3

grounding

- operation, 5-16

I

instruction documentation

- symbol, 1-7

instrument markings, 1-7

instrument serial number

- compare, 7-44
- load, 7-44

ISM1-A mark, 1-7

ISO 17025 standards

- compliant calibration, Option 1A7, 2-4

K

keyboard

- manual check, 7-44

keypad

- illustrated, 6-4
- part number, 6-4
- removal and replacement, 7-21

Keysight

- contacting, 2-5

kickstand

- removal and replacement, 7-7

L

LAN interface

- general information, 5-31

LCD

- illustrated, 6-4
- manual check, 7-44
- operation, 5-5
- parts list, 6-4
- removal and replacement, 7-21

LCD shield

- removal and replacement, 7-21

lithium battery disposal, 1-8

load

- instrument serial number, 7-44

M

main battery

- removal and replacement, 7-6

maintenance

- battery maintenance, 8-7
- cleaning, 2-2
- cleaning the display, 8-7

manual check

- keyboard, 7-44
- LCD, 7-44
- RPG, 7-44

manual checks and

- procedures, 7-44

measurement group

- operation, 5-6
- troubleshooting, 4-8

measurement group assemblies

removal and

- replacement, 7-29

miscellaneous replaceable

parts

- part numbers, 6-12

N

N7841A performance tests, 3-8

O

operating modes, 5-20

- CAT and NA, 5-21

- PM, 5-25

- SA, 5-24

operation

- A4 RF board, 5-6

- A5 system board, 5-10

- A6 SOM board, 5-15

- battery, 5-15, 5-18

- battery charging

- management, 5-18

- CAT and NA modes, 5-21

- CPU board, 5-15

- front panel group, 5-4

- front panel interface board, 5-4

- grounding, 5-16

- in modes, 5-20

- LCD, 5-5

- measurement group, 5-6

- PM mode, 5-25

- power, 5-16

- power control, 5-16

- power management, 5-16

- power states, 5-16

- power supplies, 5-16

- SA mode, 5-24

- smart power

- management, 5-16

- theory of, 5-2

- operational check, 3-7

- operational files, 5-29

option

- calibration, 2-4

- service and support, 2-4

Option 1A7

- ISO 17025 standards

- compliant calibration, 2-4

Option A6J

- ANSI Z540 standards
 - compliant calibration, 2-4
- Option UK6
 - commercial calibration, 2-4
- options
 - analyzer, 2-3
 - re-installing options, 8-4
 - view currently installed options, 8-4
- ordering information
 - replaceable parts, 6-2
- P
- part numbers
 - documentation, 6-13
 - repair and reassembly kit, 6-12
 - replaceable parts
 - in front panel assembly, 6-4
 - miscellaneous analyzer, 6-12
 - supplies
 - ESD, 6-13
 - tools
 - service, 6-12
- parts
 - in front panel
 - illustrated, 6-4
 - in front panel assembly
 - part numbers, 6-4
 - miscellaneous
 - part numbers, 6-12
 - replaceable
 - listing of, 6-4
 - ordering information, 6-2
- performance
 - tests, N7841A, 3-8
- post-repair procedures, 7-44
- power
 - control, 5-16
 - management, 5-16
 - operation, 5-16
 - smart management operation, 5-16
 - states, 5-16
 - supplies, 5-16
- pre-repair procedures
 - caution about, 7-2
 - warnings about, 7-2
- protection
 - against ESD, 1-5, 3-3, 4-2, 7-3
- Q
- QuickCal, 5-27
- R
- removing
 - assemblies, *See specific assembly.*
 - parts, *See specific part.*
- repair
 - post-repair procedures, 7-44
 - procedures
 - caution about, 7-2
 - warnings about, 7-2
- repair and reassembly kit
 - contents, 6-12
 - part number, 6-12
- replaceable parts
 - in front panel
 - illustrated, 6-4
 - in front panel assembly
 - part numbers, 6-4
 - listing of, 6-4
 - miscellaneous analyzer
 - part numbers, 6-12
 - ordering information, 6-2
- replacement
 - A1 keypad, 7-7
 - A2 LCD, 7-21
 - A3 front panel interface board, 7-21
 - A5 system board, 7-29
 - A6 SOM board, 7-29
 - assembly
 - cautions about, 7-4
 - list of procedures, 7-5
 - sequence, 6-3, 7-4
 - warnings about, 7-4
- case group
 - procedure, 7-7
- CPU board, 7-29
- front panel group
 - assemblies, 7-21
- LCD shield, 7-21
- main battery, 7-6
- measurement group
 - assemblies, 7-29
- RF assembly, 7-29
- RF connectors, 7-29
- RF top assembly, 7-29
- RPG, 7-21
- RPG knob, 7-21
- RTC battery, 7-21
- replacement sequence, 4-3
- returning to customer checklist, 3-6
- RF assembly
 - removal and replacement, 7-29
- RF board
 - operation, 5-6
- RF connectors
 - removal and replacement, 7-29
- RF top assembly
 - removal and replacement, 7-29
- RPG
 - manual check, 7-44
 - removal and replacement, 7-21
- RPG knob
 - removal and replacement, 7-21
- RTC battery
 - removal and replacement, 7-21
- S
- safety
 - considerations, 1-3
 - earth ground, 1-3
 - symbols, 1-2
- screen
 - temp, 5-26
- SD card
 - used to install firmware, 7-44
- service
 - battery maintenance, 8-7
 - cleaning the display, 8-7
 - contacting Keysight, 2-5
 - erase user data utility, 8-2
 - options, 2-4
 - procedures
 - caution about, 7-2

- post-repair, 7-44
- warnings about, 7-2
- related user operations, 8-2
- static safety parts
 - part numbers, 6-13
- tools
 - part numbers, 6-12
- view current firmware
 - revision, 8-2
- view currently installed
 - options, 8-2
- view temperature
 - readings, 8-2
- view the error log, 8-2
- warranty
 - standard, 2-4
- service test equipment, 3-5
- shipment for service or repair, 2-5
- smart power management
 - operation, 5-16
- SOM board
 - operation, 5-15
- standards compliant
 - calibration
 - ANSI Z540, Option A6J, 2-4
 - ISO 17025, Option 1A7, 2-4
- strap handle
 - removal and replacement, 7-7
- supplies
 - ESD
 - part numbers, 6-13
- support
 - contacting Keysight, 2-5
 - options, 2-4
- system board
 - operation, 5-10

T

- temperature
 - battery pack, 5-26
 - related information, 5-26
 - screen, 5-26
- test equipment
 - service, 3-5
- tests, 3-9
 - performance, N7841A, 3-8
- tools
 - service, part numbers, 6-12
- troubleshooting

- front panel group, 4-7
- measurement group, 4-8
- power up, 4-6
- where to begin, 4-4

U

- upgrades
 - firmware, 5-29
- user accessible files, 5-29
- user data
 - erase utility, 8-2

V

- view
 - current firmware revision, 8-2
 - currently installed
 - options, 8-2, 8-4
 - temperature readings, 8-2
 - the error log, 8-2

W

- warm up
 - analyzer, 3-3
- warning, 1-2
- warranty
 - service
 - standard, 2-4

This information is subject to change without notice.
© Keysight Technologies 2008 - 2018
August 2018



N9912-90003
www.keysight.com