

Fundamentals of RF and Microwave Power Measurements (Part 1)

Introduction to power, history, definitions,
international standards & traceability

Fundamentals of RF and Microwave Power Measurements (Part 1)

Introduction to power, history, definitions, international standards, and traceability AN 1449-1, literature number 5988-9213EN

Part 1 introduces the historical basis for power measurements, and provides definitions for average, peak, and complex modulations. This application note overviews various sensor technologies needed for the diversity of test signals. It describes the hierarchy of international power traceability, yielding comparison to national standards at worldwide national measurement institutes (NMIs) like the U.S. National Institute of Standards and Technology. Finally, the theory and practice of power sensor comparison procedures are examined with regard to transferring calibration factors and uncertainties. A glossary is included which serves all four parts.

Fundamentals of RF and Microwave Power Measurements (Part 2)

Power sensors and instrumentation AN 1449-1, literature number 5988-9214EN

Part 2 presents all the viable sensor technologies required to exploit the wide range of unknown modulations and signals under test. It starts with explanations of the sensor technologies, and how they came to be to meet certain measurement needs. Sensor choices range from the venerable thermistor to the innovative thermocouple to more recent improvements in diode sensors. In particular, clever variations of diode combinations are presented, which achieve ultra-wide dynamic range and square-law detection for complex modulations. New instrumentation technologies, which are underpinned with powerful computational processors, achieve new data performance.

Fundamentals of RF and Microwave Power Measurements (Part 3)

Power measurement uncertainty per international guides AN 1449-1, literature number 5988-9215EN

Part 3 discusses the all-important theory and practice of expressing measurement uncertainty, mismatch considerations, signal flowgraphs, ISO 17025, and examples of typical calculations. Considerable detail is shown on the ISO 17025, *Guide for the Expression of Measurement Uncertainties*, has become the international standard for determining operating specifications. Keysight Technologies, Inc. has transitioned from ANSI/NCSL Z540-1-1994 to ISO 17025.

Fundamentals of RF and Microwave Power Measurements (Part 4)

An overview of Keysight instrumentation for RF/microwave power measurements AN 1449-1, literature number 5988-9216EN

Part 4 overviews various instrumentation for measuring RF and microwave power, including spectrum analyzers, microwave receivers, network/spectrum analyzers, and the most accurate method, power sensors/meters. It begins with the unknown signal, of arbitrary modulation format, and draws application-oriented comparisons for selection of the best instrumentation technology and products.

Most of the chapter is devoted to the most accurate method, power meters and sensors. It includes comprehensive selection guides, frequency coverages, contrasting accuracy and dynamic performance to pulsed and complex digital modulations. These are especially crucial now with the advances in wireless communications formats and their statistical measurement needs.

Fundamentals of RF and microwave power measurements (part 1)

For user convenience, Keysight's *Fundamentals of RF and Microwave Power Measurements*, application note 64-1, literature number 5965-6330E, has been updated and segmented into four technical subject groupings. The following abstracts explain how the total field of power measurement fundamentals is now presented.

Table of Contents

Introduction	5
The Importance of Power	6
A Brief History of Power Measurements	7
Power Measurement Fundamentals	10
Understanding the Characteristics of the Signal Under Test.....	10
Units and Definitions	11
IEEE Video Pulse Standards Adapted for Microwave Pulses	17
Peak Power Waveform Definitions	19
A Typical Wireless Modulation Format	20
Three Technologies for Sensing Power.....	20
An Overview of Power Sensors and Meters for Pulsed and Complex Modulations	21
Key Power Sensor Parameters.....	21
Data Computation for Statistical Parameters of Power Analysis	23
The Chain of Power Traceability.....	24
The Hierarchy of Power Measurements, National Standards and Traceability	24
The Theory and Practice of Sensor Calibration	27
Some Measurement Considerations for Power Sensor Comparisons	28
Typical Sensor Comparison System.....	28
Thermistors as Power Transfer Standards	31
Other DC-Substitution Meters.....	31
Peak Power Sensor Calibration Traceability.....	31
Network Analyzer Source Method	32
NIST Six-Port Calibration System.....	32
General References	33
Glossary and List of Symbols.....	33

Introduction

The purpose of the new series of *Fundamentals of RF and Microwave Power Measurements* application notes, which were leveraged from former note 64-1, is to:

1. Retain tutorial information about historical and fundamental considerations of RF/microwave power measurements and technology which tend to remain timeless.
2. Provide current information on new meter and sensor technology.
3. Present the latest modern power measurement techniques and test equipment that represents the current state-of-the-art.

Part 1, Chapter 1 reviews the commercial and technical importance of making power measurements, equity in trade, the cost of measurement uncertainties, and the need for two power measurements of the same unit under test will be the same at two locations in the world. It then presents a brief history of power techniques, and additionally a history of peak power techniques.

Chapter 2 shows why it is crucial to begin a power measurement task with a clear understanding of the characteristics of the signal under test. With the advent of new complex combinations of modulations in the 1990s and forward, it also presents signal format considerations that users must evaluate when pondering which sensor technologies to use.

The application notes then defines the variety of terminology of units and definitions of various power measuring terms. It shows how IEEE video pulse standards were adapted by Keysight for use in microwave pulsed power envelopes. Brief descriptions of modern wireless formats show how key sensor performance is required to faithfully capture the system power. Various sensor technologies and instrumentation are previewed from the complete descriptions in *Fundamentals Part 2*.

Considerations necessary for capturing and digitizing microwave signals which are used in modern wireless systems are presented. These often consist of pulsed carriers plus digital phase modulations, which look like noise, combined on the same signal. When measured with digital sampling type instrumentation, the powerful micro-processors can run statistical routines to reveal computed data, oriented to particular customer requirements.

Chapter 3 presents the matter of basic measurement traceability to national and world standards. It describes the hierarchy of international traceability, including comparison processes to national standards at worldwide NMIs such as the U.S. National Institute of Standards and Technology, Boulder, CO.

The application note reviews the theory and practice of sensor calibration processes and the need for transportable sensor artifacts which can transfer higher-echelon uncertainties of the NMIs to company primary lab standards. It reviews special procedures needed for extended calibration processes on pulse-power sensors.

Note: In this application note numerous technical references will be made to the other published parts of the *Fundamentals of RF and Microwave Power Measurements* series. For brevity, we will use the format *Fundamentals Part X*. This should insure that you can quickly locate the concept in the other publication. Brief abstracts for the four-part series are provided on the inside the front cover.

The importance of power

The output power level of a system or component is frequently the critical factor in the design, and ultimately the purchase and performance of almost all radio frequency and microwave equipment. The first key factor is the concept of equity in trade. When a customer purchases a product with specified power performance for a negotiated price, the final production-line test results need to agree with the customer's incoming inspection data. These shipping, receiving, installation or commissioning phases often occur at different locations, and sometimes across national borders. The various measurements must be consistent within acceptable uncertainties.

Secondly, measurement uncertainties cause ambiguities in the realizable performance of a transmitter. For example, a 10-W transmitter costs more than a 5-W transmitter. Twice the power output means twice the geographical area is covered or 40% more radial range for a communication system. Yet, if the overall measurement uncertainty of the final product test is on the order of ± 0.5 dB, the unit actually shipped could have output power as much as 10% lower than the customer expects, with resulting lower operating margins.

Because signal power level is so important to the overall system performance, it is also critical when specifying the components that build up the system. Each component of a signal chain must receive the proper signal level from the previous component and pass the proper level to the succeeding component. Power is so important that it is frequently measured twice at each level, once by the vendor and again at the incoming inspection stations before beginning the next assembly level. It is at the higher operating power levels where each decibel increase in power level becomes more costly in terms of complexity of design, expense of active devices, skill in manufacture, difficulty of testing, and degree of reliability.

The increased cost per dB of power level is especially true at microwave frequencies, where the high-power solid state devices are inherently more costly and the guard-bands designed into the circuits to avoid maximum device stress are also quite costly. Many systems are continuously monitored for output power during ordinary operation. This large number of power measurements and their importance dictates that the measurement equipment and techniques be accurate, repeatable, traceable, and convenient.

The goal of this application note, and others, is to guide the reader in making those measurement qualities routine. Because many of the examples cited above used the term "signal level," the natural tendency might be to suggest measuring voltage instead of power. At low frequencies, below about 100 kHz, power is usually calculated from voltage measurements across an assumed impedance. As the frequency increases, the impedance has large variations, so power measurements become more popular, and voltage or current are the calculated parameters. At frequencies from about 30 MHz on up through the optical spectrum, the direct measurement of power is more accurate and easier. Another example of decreased usefulness is in waveguide transmission configurations where voltage and current conditions are more difficult to define.

A brief history of power measurements

From the earliest design and application of RF and microwave systems, it was necessary to determine the level of power output. Some of the techniques were quite primitive by today's standards. For example, when Sigurd and Russell Varian, the inventors of the klystron microwave power tube in the late 1930s, were in the early experimental stages of their klystron cavity, the detection diodes of the day were not adequate for those microwave frequencies. The story is told that Russell cleverly drilled a small hole at the appropriate position in the klystron cavity wall, and positioned a fluorescent screen alongside. This technique was adequate to reveal whether the cavity was in oscillation and to give a gross indication of power level changes as various drive conditions were adjusted.

Some early measurements of high-power system signals were accomplished by arranging to absorb the bulk of the system power into some sort of termination and measuring the heat buildup versus time. A simple example used for high power radar systems was the water-flow calorimeter. These were made by fabricating a glass or low-dielectric-loss tube through the sidewall of the waveguide at a shallow angle. Since the water was an excellent absorber of the microwave energy, the power measurement required only a measurement of the heat rise of the water from input to output and a measure of the volumetric flow versus time. The useful part of that technique was that the water flow also carried off the considerable heat from the source under test at the same time it was measuring the desired parameter. This was especially important for measurements on kilowatt and megawatt microwave sources.

Going into World War II, as detection crystal technology grew from the early galena cat-whiskers, detectors became more rugged and performed at higher RF and microwave frequencies. They were better matched to transmission lines, and by using comparison techniques with sensitive detectors, unknown microwave power could be measured against known values of power generated by calibrated signal generators.

Power substitution methods emerged with the advent of sensing elements which were designed to couple transmission line power into the tiny sensing element.¹ Barretters were positive-temperature-coefficient elements, typically metallic fuses, but they were frustratingly fragile and easy to burn out. Thermistor sensors exhibited a negative temperature coefficient and were much more rugged. By including such sensing elements as one arm of a 4-arm balanced bridge, DC or low-frequency AC power could be withdrawn as RF/MW power was applied, maintaining the bridge balance and yielding a substitution value of power.²

Through the 1950s and 60s, coaxial and waveguide thermistor sensors were the work-horse technology. Keysight was a leading innovator in sensors and power meters with recognizable model numbers such as 430, 431 and 432. As the thermocouple sensor technology entered in the early 1970s, it was accompanied by digital instrumentation. This led to a family of power meters that were exceptionally long-lived, with model numbers such as 435, 436, 437, and 438.

1. B.P. Hand, "Direct Reading UHF Power Measurement," Hewlett-Packard Journal, Vol. 1, No. 59 (May, 1950).
2. E.L. Ginzton, "Microwave Measurements," McGraw-Hill, Inc., 1957.

Commercial calorimeters also had a place in early measurements. Dry calorimeters absorbed system power and by measurement of heat rise versus time, were able to determine system power. Keysight's 434A power meter (circa, 1960) was an oil-flow calorimeter, with a 10-W top range, which also used a heat comparison between the RF load and another identical load driven by DC power.¹ Water-flow calorimeters were offered by several vendors for medium to high power levels.

A history of peak power measurements

Historically, the development of radar and navigation systems in the late 1930s led to the application of pulsed RF and microwave power. Magnetrons and klystrons were invented to provide the pulsed power, and, therefore, peak power measurement methods developed concurrently. Since the basic performance of those systems depended primarily on the peak power radiated, it was important to have reliable measurements.²

Early approaches to pulse power measurement have included the following techniques: 1) calculation from average power and duty cycle data; 2) notch wattmeter; 3) DC-pulse power comparison; 4) barretter integration. Most straightforward is the method of measuring power with a typical averaging sensor, and dividing the result by the duty cycle measured with a video detector and an oscilloscope.

The notch wattmeter method arranged to combine the unknown pulsed signal with another comparison signal usually from a calibrated signal generator, into a single detector. By appropriate video synchronization, the generator signal was "notched out" to zero power at the precise time the unknown RF pulse occurred. A microwave detector responded to the combined power, which allowed the user to set the two power levels to be equal on an oscilloscope trace. The unknown microwave pulse was equal to the known signal generator level, corrected for the signal attenuation in the two paths.

The DC-power comparison method involved calibrating a stable microwave detector with known power levels across its dynamic range, up into its linear detection region. Then, unknown pulsed power could be related to the calibration chart. Keysight's early 8900A peak power meter (acquired as part of the Boonton Radio acquisition in the early 1960s) was an example of that method. It used a biased detector technique to improve stability, and measured in the 50 to 2000 MHz range, which made it ideal for the emerging navigation pulsed applications of the 1960s.

Finally, barretter integration instrumentation was an innovative solution which depended on measuring the fast temperature rise in a tiny metal wire sensor (barretter) which absorbed the unknown peak power.³ By determining the slope of the temperature rise in the sensor, the peak power could be measured, the higher the peak, the faster the heat rise and greater the heat slope. The measurement was quite valid and independent of pulse width, but unfortunately, barretters were fragile and lacked great dynamic range. Other peak power meters were offered to industry in the intervening years.

1. B.P. Hand, "An Automatic DC to X-Band Power Meter for the Medium Power Range," Hewlett-Packard Journal, Vol. 9, No. 12 (Aug., 1958).

2. M. Skolnik, "Introduction to Radar Systems," McGraw-Hill, Inc., (1962).

3. R.E. Henning, "Peak Power Measurement Technique," Sperry Engineering Review, (May-June 1955).

A major advance in peak power instrumentation was introduced in 1990, the 8990A peak power analyzer. This instrument and its associated dual peak power sensors provided complete analysis of the envelope of pulsed RF and microwave power to 40 GHz. The analyzer was able to measure or compute 13 different parameters of a pulse waveform: 8 time values such as pulse width and duty cycle, and 5 amplitude parameters such as peak power and pulse top amplitude.

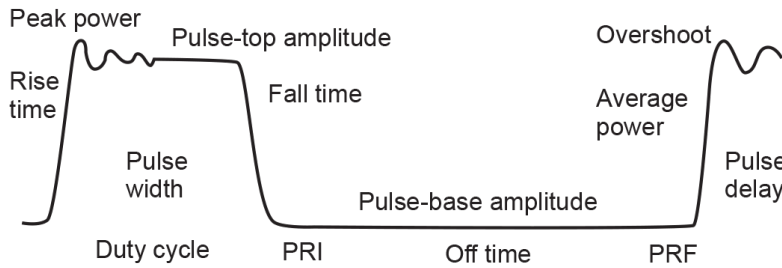

Figure 1-1. Typical envelope of pulsed system with overshoot and pulse ringing, shown with 13 pulse parameters which the Keysight 8990A characterized for time and amplitude.

Because it was really the first peak power analyzer which measured so many pulse parameters, Keysight chose that point to define for the industry certain pulse features in statistical terms, extending older IEEE definitions of video pulse characteristics. One reason was that the digital signal processes inside the instrument were themselves based on statistical methods. These pulsed power definitions are fully elaborated in Chapter II on definitions.

However, as the new wireless communications revolution of the 1990s took over, the need for instruments to characterize complex digital modulation formats led to the introduction of the Keysight E4416/17A peak and average power meters, and to the retirement of the 8990 meter. Complete descriptions of the new peak and average sensors, and meters and envelope characterization processes known as “time-gated” measurements are given in *Fundamentals Part 2*.

This application note allocates most of its space to the more modern, convenient, and wider dynamic range sensor technologies that have developed since those early days of RF and microwave. Yet, it is hoped that the reader will reserve some appreciation for those early developers in this field for having endured the inconvenience and primitive equipment of those times.

Power Measurement Fundamentals

Understanding the characteristics of the signal under test

The associated application note, Fundamentals Part 2, will be presenting the variety of power sensor technologies. There are basically four different sensor choices for detecting and characterizing power. It should be no surprise that all are needed, since users need to match the best sensor performance to the specific modulation formats of their signals under test. Users often need to have data pre-computed into formats common to their industry specifications. An example would be to measure, compute and display peak-to-average power ratio.

System technology trends in modern communications, radar and navigation signals have resulted in dramatically new modulation formats, some of which have become highly complex. Some radar and EW (countermeasures) transmitters use spread spectrum or frequency-chirped and complex phase-coded pulse configurations. These are used to reveal more precise data on the unknown target returns.

New wireless systems depend on digital modulations at very high data rates, and other spread-spectrum formats. Some combine these digital data with pulsed time-share, and have precise requirements on rise times and off-time noise levels, see Figure 2-1. In other production and field measurements, a cellular base station transmitter might combine many channels of modulated carriers, through the same broadband power amplifier and up to the antennas. This can result in some statistical processes working to create extremely high peak power spikes, based on a concept called “crest factor.” Such spikes need to be captured by the power metering, to assure that amplifier saturation will not occur. If it does, it creates intermodulation that smears one sub-carrier into another.

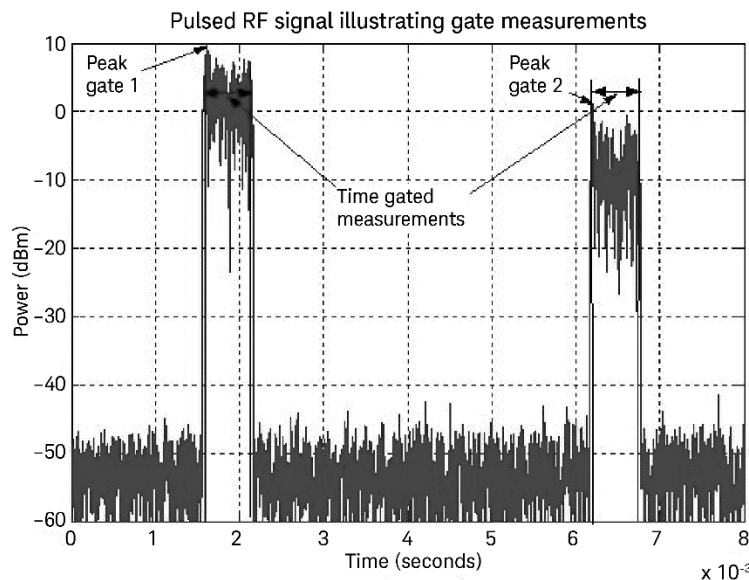

Figure 2-1. This time-gated wireless signal format requires accurate determination of peak power, average power and peak-to-average ratio.

Multiple signals, whether intentional or unintentional always stress a power sensor's ability to integrate power, or to capture the modulation envelope. Average power sensors such as thermistors and thermocouples inherently capture all power. No matter what the format, they respond to the heat generated by the signal under test. Diode sensors, feature much more sensitivity and dynamic range, but their conversion characteristic ranges from square law detection (input power proportional to output voltage) through a quasi-squarelaw region, to a linear region (input voltage proportional to output voltage).

Thus diode sensors can often be substituted for thermal sensors within their square-law range, but if peak power or crest factors caused spikes of RF/microwave to exceed the square-law range, data errors will result. Diode sensors are the only choice for characterizing pulsed waveform modulation envelopes or time-dependent formats like spread-spectrum used in wireless systems.

Modern peak and average diode sensors are pre-calibrated for operation across a wide dynamic range from square-law through the transition region to linear detection. They do it by capturing calibration data and storing it internal to the sensor component in an EEPROM. This correction data is then accessed for the final digital readout of the associated instrument. Diode calibration data also includes corrections for the all-important sensitivity to temperature environments. Complete information on peak and average diode sensors is given in *Fundamentals Part 2*.

Units and definitions

Watt

The International System of Units (SI) has established the watt (W) as the unit of power; one watt is one joule per second. Interestingly, electrical quantities do not even enter into this definition of power. In fact, other electrical units are derived from the watt. A volt is one watt per ampere. By the use of appropriate standard prefixes the watt becomes the kilowatt (1 kW = 10³ W), milliwatt (1 mW = 10⁻³ W), microwatt (1 μW = 10⁻⁶ W), nanowatt (1 nW = 10⁻⁹ W), etc.

dB

In many cases, such as when measuring gain or attenuation, the ratio of two powers, or relative power, is frequently the desired quantity rather than absolute power. Relative power is the ratio of one power level, P, to some other level or reference level, P_{ref}. The ratio is dimensionless because the units of both the numerator and denominator are watts. Relative power is usually expressed in decibels (dB).

The dB is defined by

$$dB = 10 \log_{10} \left(\frac{P}{P_{ref}} \right)$$

(Equation 2-1)

The use of dB has two advantages. First, the range of numbers commonly used is more compact; for example +63 dB to –153 dB is more concise than 2×10^6 to 0.5×10^{-15} . The second advantage is apparent when it is necessary to find the gain of several cascaded devices. Multiplication of numeric gain is then replaced by the addition of the power gain in dB for each device.

dBm

Popular usage has added another convenient unit, dBm. The formula for dBm is similar to the dB formula except that the denominator, P_{ref} , is always one milliwatt:

$$dB = 10 \log_{10} \left(\frac{P}{1 \text{ mW}} \right)$$

(Equation 2-2)

In this expression, P is expressed in milliwatts and is the only variable, so dBm is used as a measure of absolute power. An oscillator, for example, may be said to have a power output of 13 dBm. By solving for P using the dBm equation, the power output can also be expressed as 20 mW. So dBm means “dB above one milliwatt” (no sign is assumed positive) but a negative dBm is to be interpreted as “dB below one milliwatt.” The advantages of the term dBm parallel those for dB; it uses compact numbers and allows the use of addition instead of multiplication when cascading gains or losses in a transmission system.

Power

The term “average power” is very popular and is used in specifying almost all RF and microwave systems. The terms “pulse power” and “peak envelope power” are more pertinent to radar and navigation systems, and recently, TDMA signals in wireless communication systems.

In elementary theory, power is said to be the product of voltage (V) and current (I). But for an AC voltage cycle, this product $V \times I$ varies during the cycle as shown by curve P in Figure 2-2, according to a $2f$ relationship. From that example, a sinusoidal generator produces a sinusoidal current as expected, but the product of voltage and current has a DC term as well as a component at twice the generator frequency. The word “power” as most commonly used, refers to that DC component of the power product.

All the methods of measuring power to be discussed (except for one chapter on peak power measurement) use power sensors which, by averaging, respond to the DC component. Peak power instruments and sensors have time constants in the sub-microsecond region, allowing measurement of pulsed power modulation envelopes.

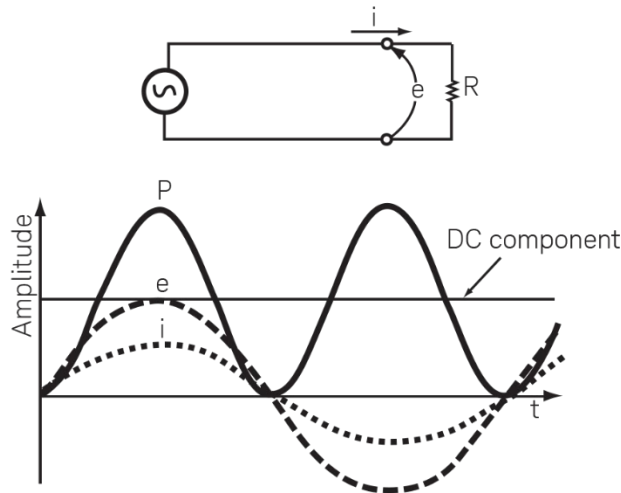

Figure 2-2. The product of voltage and current, P , varies during the sinusoidal cycle.

The fundamental definition of power is energy per unit time. This corresponds with the definition of a watt as energy transfer at the rate of one joule per second. The important question to resolve is over what time is the energy transfer rate to be averaged when measuring or computing power? From Figure 2-2 it is clear that if a narrow time interval is shifted around within one cycle, varying answers for energy transfer rate are found. But at radio and microwave frequencies, such microscopic views of the voltage-current product are not common. For this application note, power is defined as the energy transfer per unit time averaged over many periods of the lowest frequency (RF or microwave) involved.

A more mathematical approach to power for a continuous wave (CW) is to find the average height under the curve of P in Figure 2-2. Averaging is done by finding the area under the curve, that is by integrating, and then dividing by the length of time over which that area is taken. The length of time should be an exact number of AC periods. The power of a CW signal at frequency $(1/T_0)$ is:

$$P = \frac{1}{nT_0} \int_0^{nT_0} e_p \sin\left(\frac{2\pi}{T_0} t\right) @ i_p \sin\left(\frac{2\pi}{T_0} t + \Phi\right) dt$$

(Equation 2-3)

where T_0 is the AC period, e_p and i_p represent peak values of e and i , ϕ is the phase angle between e and i , and n is the number of AC periods. This yields (for $n = 1, 2, 3 \dots$):

$$P = \frac{e_p i_p}{2} \cos \Phi$$

(Equation 2-4)

If the integration time is many AC periods long, then, whether or not n is a precise integer makes a vanishingly small difference. This result for large n is the basis of power measurement.

For sinusoidal signals, circuit theory shows the relationship between peak and rms values as:

$$e_p = \sqrt{2}E_{rms} \text{ and } i_p = \sqrt{2}I_{rms}$$

(Equation 2-5)

Using these in (2-4) yields the familiar expression for power:

$$P = E_{rms} @ I_{rms} \cos \Phi$$

(Equation 2-6)

Average power

Average power, like the other power terms to be defined, places further restrictions on the averaging time than just “many periods of the highest frequency.” Average power means that the energy transfer rate is to be averaged over many periods of the lowest frequency involved. For a CW signal, the lowest frequency and highest frequency are the same, so average power and power are the same. For an amplitude modulated wave, the power must be averaged over many periods of the modulation component of the signal as well.

In a more mathematical sense, average power can be written as:

$$P_{avg} = \frac{1}{nT} \int_0^{nT} e(t) \cdot i(t) dt$$

(Equation 2-7)

where T is the period of the lowest frequency component of $e(t)$ and $i(t)$. The averaging time for average power sensors and meters is typically from several hundredths of a second to several seconds and therefore this process obtains the average of most common forms of amplitude modulation.

Pulse power

For pulse power, the energy transfer rate is averaged over the pulse width, t . Pulse width t is considered to be the time between the 50% risetime/ fall-time amplitude points.

Mathematically, pulse power is given by:

$$P_p = \frac{1}{\tau} \int_0^{\tau} e(t) @ i(t) dt$$

(Equation 2-8)

By its very definition, pulse power averages out any aberrations in the pulse envelope such as overshoot or ringing. For this reason it is called pulse power and not peak power or peak pulse power as is done in many radar references. The terms peak power and peak pulse power are not used here for that reason. Building on IEEE video pulse definitions, pulse-top amplitude also describes the pulse-top power averaged over its pulse width. Peak power refers to the highest power point of the pulse top, usually the risetime overshoot. See IEEE definitions below.

The definition of pulse power has been extended since the early days of microwave to be:

$$P_p = \frac{P_{avg}}{Duty\ cycle}$$

(Equation 2-9)

where duty cycle is the pulse width times the repetition frequency. See Figure 2-3. This extended definition, which can be derived from Equations 2-7 and 2-8 for rectangular pulses, allows calculation of pulse power from an average power measurement and the duty cycle.

For microwave systems which are designed for a fixed duty cycle, peak power is often calculated by use of the duty cycle calculation along with an average power sensor. See Figure 2-3. One reason is that the instrumentation is less expensive, and in a technical sense, the averaging technique integrates all the pulse imperfections into the average.

The evolution of highly sophisticated radar, electronic warfare and navigation systems, which is often based on complex pulsed and spread spectrum technology, has led to more sophisticated instrumentation for characterizing pulsed RF power. Fundamentals Part 2 presents the theory and practice of peak and average sensors and instrumentation.

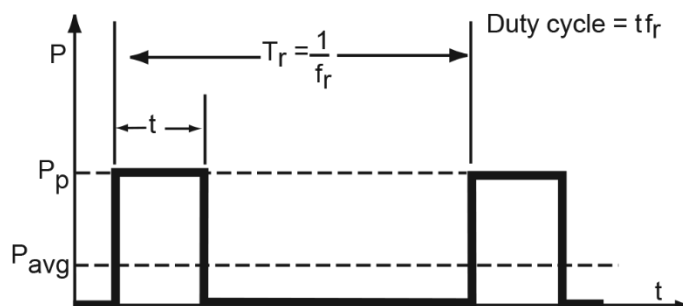

Figure 2-3. Pulse power P_p is averaged over the pulse width.

Peak envelope power

For certain more sophisticated, microwave applications and because of the need for greater accuracy, the concept of pulse power is not totally satisfactory. Difficulties arise when the pulse is intentionally non-rectangular or when aberrations do not allow an accurate determination of pulse width t . Figure 2-4 shows an example of a Gaussian pulse shape used in certain navigation systems, where pulse power, by either Equation 2-8 or 2-9, does not give a true picture of power in the pulse. Peak envelope power is a term for describing the maximum power. Envelope power will first be discussed.

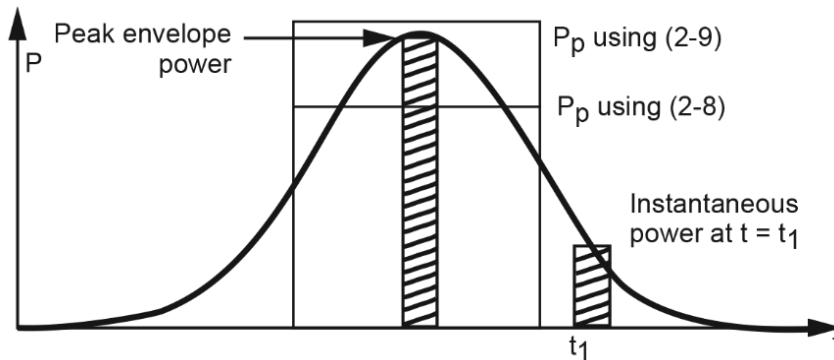

Figure 2-4. A Gaussian pulse and the different kinds of power.

Envelope power is measured by making the averaging time greater than $1/f_m$ where f_m is the maximum frequency component of the modulation waveform. The averaging time is therefore limited on both ends: (1) it must be large compared to the period of the highest modulation frequency, and (2) it must be small compared to the carrier.

By continuously displaying the envelope power on an oscilloscope (using a detector operating in its square-law range), the oscilloscope trace will show the power profile of the pulse shape. (Square law means the detected output voltage is proportional to the input RF power, that is the square of the input voltage.) Peak envelope power, then, is the maximum value of the envelope power.

Average power, pulse power, and peak envelope power all yield the same answer for a CW signal. Of all power measurements, average power is the most frequently measured because of convenient measurement equipment with highly accurate and traceable specifications.

IEEE video pulse standards adapted for microwave pulses

As mentioned in Chapter 1, the 1990 introduction of the Keysight 8990 peak power analyzer (now discontinued) resulted in the promulgation of some new terminology for pulsed power, intended to define pulsed RF/microwave waveforms more precisely. For industry consistency, Keysight chose to extend older IEEE definitions of video pulse characteristics into the RF/microwave domain.

One reason that pulsed power is more difficult to measure is that user-waveform envelopes under test may need many different parameters to characterize the power flow as shown in Figure 2-5.

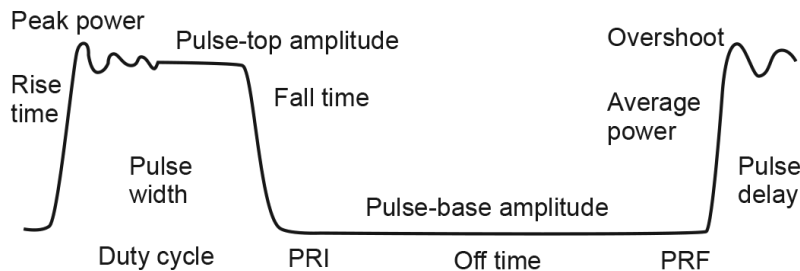

Figure 2-5. Typical envelope of pulsed system with overshoot and pulse ringing, shown with 13 pulse parameters which characterize time and amplitude.

Two IEEE video standards were used to implement the RF/microwave definitions:

1. IEEE STD 194-1977, "IEEE Standard Pulse Terms and Definitions," July 26, 1977.¹
2. ANSI/IEEE STD 181-1977, "IEEE Standard on Pulse Measurement and Analysis by Objective Techniques," July 22, 1977. (Revised from 181-1955, Methods of Measurement of Pulse Qualities.²

IEEE STD 194-1977 was the primary source for definitions. ANSI/IEEE STD 181 is included here for reference only, since the 8990 used statistical techniques to determine pulse top characteristics as recommended by IEEE STD 181 histogram process.

1. IEEE STD 194-1977, "IEEE Standard Pulse Terms and Definitions," (July 26, 1977), IEEE, New York, NY.

2. ANSI/IEEE STD 181-1977, "IEEE Standard on Pulse Measurement and Analysis by Objective Techniques," July 22, 1977. Revised from 181-1955, Methods of Measurement of Pulse Qualities, IEEE, New York, NY.

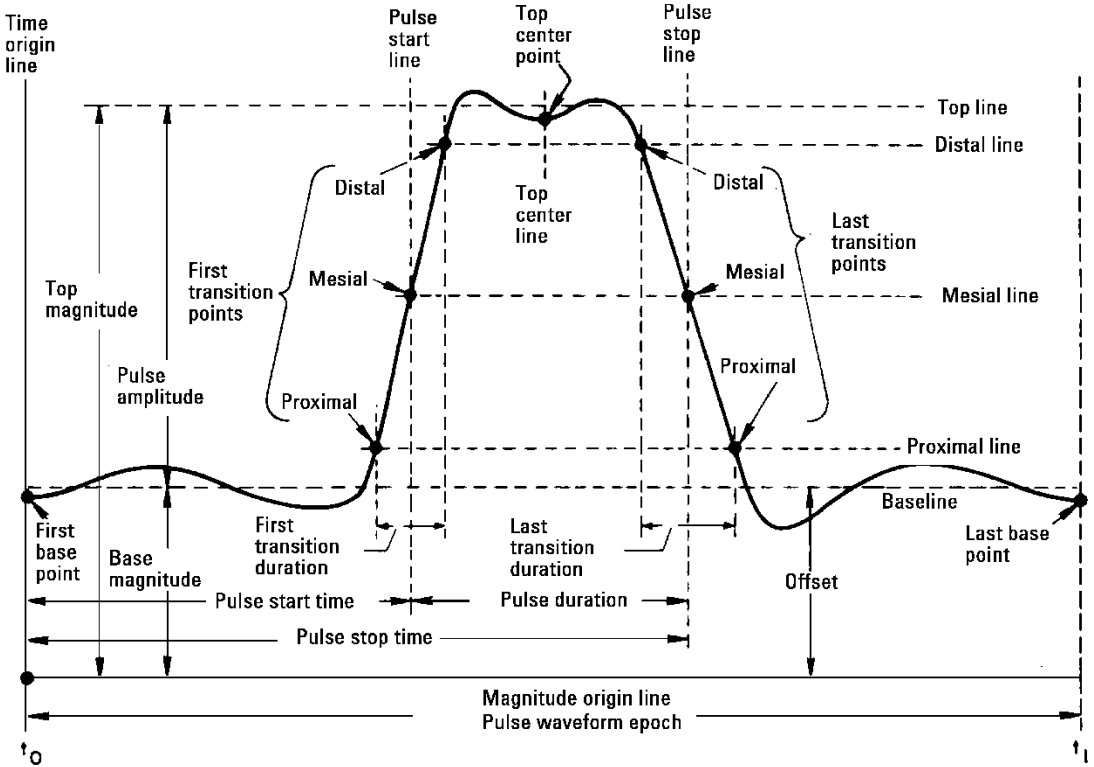

Figure 2-6. IEEE pulse definitions and standards for video parameters applied to microwave pulse envelopes. ANSI/IEEE Std 194-1977, Copyright © 1977, IEEE all rights reserved.

It was recognized that while terms and graphics from both those standards were written for video pulse characteristics, most of the measurement theory and intent of the definitions can be applied to the waveform envelopes of pulse-modulated RF and microwave carriers. Several obvious exceptions would be parameters such as pre-shoot, which is the negative-going undershoot that precedes a pulse risetime. Negative power would be meaningless. The same reasoning would apply to the undershoot following the fall time of a pulse.

For measurements of pulse parameters such as risetime or overshoot to be meaningful, the points on the waveform that are used in the measurement must be defined unambiguously. Since all the time parameters are measured between specific amplitude points on the pulse, and since all the amplitude points are referenced to the two levels named “top” and “base,” Figure 2-6 shows how they are defined.

Peak power waveform definitions

The following are definitions for 13 RF pulse parameters as adapted from IEEE video definitions:

Rise time	The time difference between the proximal and distal first transition points, usually 10 and 90% of pulse-top amplitude (vertical display is linear power).
Fall time	Same as risetime measured on the last transition.
Pulse width	The pulse duration measured at the mesial level; normally taken as the 50% power level.
Off time	Measured on the mesial (50%) power line; pulse separation, the interval between the pulse stop time of a first pulse waveform and the pulse start time of the immediately following pulse waveform in a pulse train.
Duty cycle	The previously measured pulse duration divided by the pulse repetition interval.
PRI	(Pulse repetition interval) The interval between the pulse start time of a first pulse waveform and the pulse start time of the immediately following pulse waveform in a periodic pulse train.
PRF	(pulse repetition frequency) The reciprocal of PRI.
Pulse delay	The occurrence in time of one pulse waveform before (after) another pulse waveform; usually the reference time would be a video system timing or clock pulse.
Pulse-top	Pulse amplitude, defined as the algebraic amplitude difference between the top magnitude and the base magnitude; calls for a specific procedure or algorithm, such as the histogram method. ¹
Pulse-base	The pulse waveform baseline specified to be obtained by the histogram algorithm.
Peak power	The highest point of power in the waveform, usually at the first over-shoot; it might also occur elsewhere across the pulse top if parasitic oscillations or large amplitude ringing occurs; peak power is not the pulse-top amplitude which is the primary measurement of pulse amplitude.
Overshoot	A distortion that follows a major transition; the difference between the peak power point and the pulse-top amplitude computed as a percentage of the pulse-top amplitude.
Average power	Computed by using the statistical data from pulse-top amplitude power and time measurements.

1. In such a method, the probability histogram of power samples is computed. This is split in two around the mesial line and yields a peak in each segment. Either the mode or the mean of these histograms gives the pulse top and pulse bottom power.

A typical wireless modulation format

Modern wireless system designs use TDMA (time division multiple access) and CDMA (code division multiple access) for combining many channels into broadband complex signal formats. For the typical signal of Figure 2-1, the EDGE system (enhanced data rate for GSM evolution) requires a characterization of peak, average and peak-to-average ratios during the pulse-burst interval.

The power sensor used must faithfully capture the fast rise/fall times of the system pulse, plus respond to the digital phase modulation in the time gate, without being influenced by the statistical crest factor spikes of the modulation. To render the power metering instrumentation insensitive to off-time noise, the instrument requires a time-gating function which can capture data during specified time intervals.

Modern digital computation routines provide for peak-to-average determinations. Design engineers can obtain more complicated statistical data such as the CCDF, a distribution function which states the percentage of the time a wireless signal is larger than a specified value. This is of great value in testing and troubleshooting non-linearity of power amplifiers.¹

Three technologies for sensing power

There are three popular devices for sensing and measuring average power at RF and microwave frequencies. Each of the methods uses a different kind of device to convert the RF power to a measurable DC or low frequency signal. The devices are the thermistor, the thermocouple, and the diode detector. Each of the next three chapters discusses in detail one of those devices and its associated instrumentation. *Fundamentals Part 2* discusses diode detectors used to measure pulsed and complex modulation envelopes.

Each method has some advantages and disadvantages over the others. After the individual measurement sensors are studied, the overall measurement errors are discussed in *Fundamentals Part 2*.

The general measurement technique for average power is to attach a properly calibrated sensor to the transmission line port at which the unknown power is to be measured. The output from the sensor is connected to an appropriate power meter. The RF power to the sensor is turned off and the power meter zeroed. This operation is often referred to as “zero setting” or “zeroing.” Power is then turned on. The sensor, reacting to the new input level, sends a signal to the power meter and the new meter reading is observed.

1. Anderson, Alan, “Measuring Power Levels in Modern Communications Systems,” *Microwaves/RF*, October 2000.

An overview of power sensors and meters for pulsed and complex modulations

As the new wireless communications revolution of the 1990s took over, the need for instruments to characterize the power envelope of complex digital modulation formats led to the introduction of the Keysight E4416/17A peak and average power meters, and to the retirement of the 8990 meter. Complete descriptions of the new peak and average sensors and meters along with envelope characterization processes known as “time-gated” measurements are given in *Fundamentals Part 2*. “Time-gated” is a term that emerged from spectrum analyzer applications. It means adding a time selective control to the power measurement.

The E4416/17A peak and average meters also led to some new definitions of pulsed parameters, suitable for the communications industry. For example, burst average power is that pulsed power averaged across a TDMA pulse width. Burst average power is functionally equivalent to the earlier pulse-top amplitude of Figure 2-5. One term serves the radar applications arena and the other, the wireless arena.

Key power sensor parameters

In the ideal measurement case above, the power sensor absorbs all the power incident upon the sensor. There are two categories of non-ideal behavior that are discussed in detail in *Fundamentals Part 3*, but will be introduced here.

First, there is likely an impedance mismatch between the characteristic impedance of the RF source or transmission line and the RF input impedance of the sensor. Thus, some of the power that is incident on the sensor is reflected back toward the generator rather than dissipated in the sensor. The relationship between incident power P_i , reflected power P_r , and dissipated power P_d , is:

$$P_i = P_r + P_d \tag{Equation 2-10}$$

The relationship between P_i and P_r for a particular sensor is given by the sensor reflection coefficient magnitude P_Γ .

$$P_r = P_\Gamma^2 + P_i \tag{Equation 2-11}$$

Reflection coefficient magnitude is a very important specification for a power sensor because it contributes to the most prevalent source of error, mismatch uncertainty, which is discussed in *Fundamentals Part 3*. An ideal power sensor has a reflection coefficient of zero, no mismatch. While a $\rho\Gamma$ of 0.05 or 5% (equivalent to an SWR of approximately 1.11) is preferred for most situations, a 50% reflection coefficient would not be suitable for most situations due to the large measurement uncertainty it causes. Some early waveguide sensors were specified at a reflection coefficient of 0.35.

- Sensor and source mismatch errors
- Power sensor errors
- Power meter errors

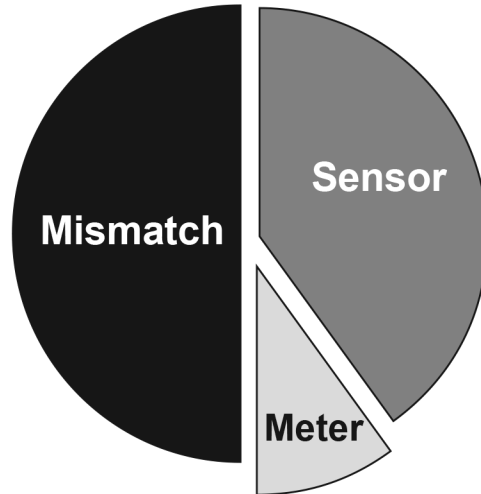

Figure 2-7. This chart shows a typical distribution of uncertainty values for its three largest causes; mismatch, sensor and meter specifications. It reveals why a low SWR specification for the power sensor is critical.

Fundamentals Part 3 will describe in great depth, the 13 individual contributors to the total measurement uncertainty of a power measurement. But one should always understand that the main culprit is the mismatch uncertainty caused by the SWR of the test signal port, which is usually uncontrollable. But, bad as the SWR of the port under test is, the mismatch uncertainty is always minimized in effect by choosing a sensor with the lowest practical SWR.¹

Previously, tuner stubs were used for narrow band measurements to maximize transmitted power. But in modern broadband systems, tuners are useless, and the better solution is to choose power sensors with the lowest possible SWR.

Another cause of non-ideal behavior occurs inside the sensor when RF power is dissipated in places other than in the power sensing element. Only the actual power dissipated in the sensor element gets metered. This effect is defined as the sensor's effective efficiency η_e . An effective efficiency of 1 (100%) means that all the power entering the sensor unit is absorbed by the sensing element and metered — no power is dissipated in conductors, sidewalls, or other components of the sensor.

The most frequently used specification of a power sensor is called the calibration factor, K_b . K_b is a combination of reflection coefficient and effective efficiency according to

$$K_b = \eta_e (1 - \rho^2)$$

(Equation 2-12)

1. Lymer, Anthony, "Improving Measurement Accuracy by Controlling Mismatch Uncertainty" TechOnLine, September 2002. Website: www.techonline.com

If a sensor has a K_b of 0.90 (90%) the power meter would normally indicate a power level that is 10% lower than the incident power P_i . Modern power sensors are calibrated at the factory and carry a calibration chart or have the correction data stored in EEPROM. Power meters then correct the lower-indicated reading by setting a calibration factor dial (or keyboard or GPIB on digital meters) on the power meter to correspond with the calibration factor of the sensor at the frequency of measurement. Calibration factor correction is not capable of correcting for the total effect of reflection coefficient, due to the unknown phase relation of source and sensor. There is still a mismatch uncertainty that is discussed in *Fundamentals Part 3*.

Data computation for statistical parameters of power analysis

With the advent of Keysight digital sampling power meters such as the E4416A/17A models, massive amounts of digital data can be harnessed to deliver power parameters far more complex than average or peak power. Since many system modulations are characterized by noisy or digitally complex envelopes, digital data points are ideal for providing computed results in formats useful to the customer.

A typical noisy waveform might be the combined channel output from a wireless base station power amplifier. For operating efficiency, many wireless channels are multi-plexed onto a single output power stage. This technique works very well as long as the power amplifier is not overdriven with crest factor signal spikes that move up out of the linear amplifier portion of the transmitter. This then presents the station installation and maintenance personnel with the responsibility of assuring the power data indicates the amplifier linearity has not been exceeded.

Modern power meters like the E4417A with appropriate computational software can process the digital data to display such power parameters as the CCDF (complementary cumulative distribution function). This parameter is critically important to design engineers who need to know what percentage of the time their peak-to-average ratio is above a specified signal level.¹

1. Breakenridge, Eric, "Use a Sampling Power Meter to Determine the Characteristics of RF and Microwave Devices," *Microwaves/RF*, September 2001

The Chain of Power Traceability

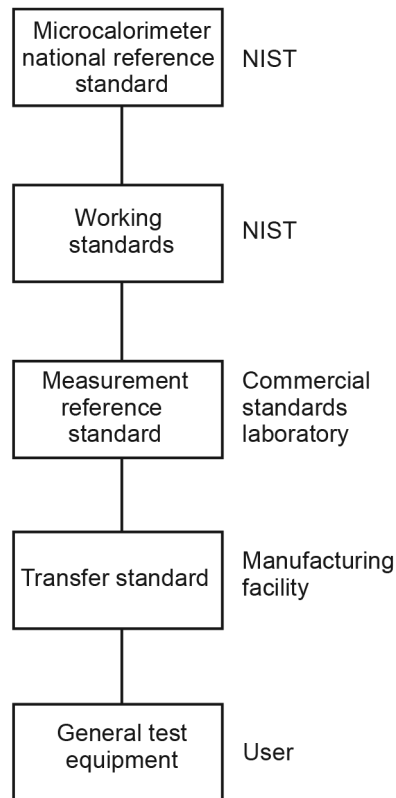

Figure 3-1. The traceability path of power references from the United States National Reference Standard.

The hierarchy of power measurements, national standards and traceability

Since power measurement has important commercial ramifications, it is important that power measurements can be duplicated at different times and at different places. This requires well-behaved equipment, good measurement technique, and common agreement as to what is the standard watt. The agreement in the United States is established by the National Institute of Standards and Technology (NIST) at Boulder, Colorado, which maintains a National Reference Standard in the form of various microwave microcalorimeters for different frequency bands.^{1, 2} When a power sensor can be referenced back to that National Reference Standard, the measurement is said to be traceable to NIST.

1. J. Wade Allen, Fred R. Clague, Neil T. Larsen, and M. P. Weidman, "NIST Microwave Power Standards in Waveguide," NIST Technical Note 1511, February 1999.
2. F.R. Clague, "A Calibration Service for Coaxial Reference Standards for Microwave Power," NIST Technical Note 1374, May, 1995.

The usual path of traceability for an ordinary power sensor is shown in Figure 3-1. At each echelon, at least one power standard is maintained for the frequency band of interest. That power sensor is periodically sent to the next higher echelon for recalibration, then returned to its original level. Recalibration intervals are established by observing the stability of a device between successive recalibrations. The process might start with recalibration every few months. Then, when the calibration is seen not to change, the interval can be extended to a year or so.

Each echelon along the traceability path adds some measurement uncertainty. Rigorous measurement assurance procedures are used at NIST because any error at that level must be included in the total uncertainty at every lower level. As a result, the cost of calibration tends to be greatest at NIST and reduces at each lower level. The measurement comparison technique for calibrating a power sensor against one at a higher echelon is discussed in other documents, especially those dealing with round robin procedures.^{1, 2}

The National Power Reference Standard for the U.S. is a microcalorimeter maintained at the NIST in Boulder, CO, for the various coaxial and waveguide frequency bands offered in their measurement services program. These measurement services are described in NIST SP-250, available from NIST on request.³ They cover coaxial mounts from 10 MHz to 50 GHz and waveguide from 18 GHz to the high millimeter ranges of 96 GHz.

A microcalorimeter measures the effective efficiency of a DC substitution sensor which is then used as the transfer standard. Microcalorimeters operate on the principle that after applying an equivalence correction, both DC and absorbed microwave power generate the same heat. Comprehensive and exhaustive analysis is required to determine the equivalence correction and account for all possible thermal and RF errors, such as losses in the transmission lines and the effect of different thermal paths within the microcalorimeter and the transfer standard. The DC-substitution technique is used because the fundamental power measurement can then be based on DC voltage (or current) and resistance standards. The traceability path leads through the microcalorimeter (for effective efficiency, a unit-less correction factor) and finally back to the national DC standards.

In addition to national measurement services, other industrial organizations often participate in comparison processes known as round robins (RR). A RR provides measurement reference data to a participating lab at very low cost compared to primary calibration processes. For example, the National Conference of Standards Laboratories International (NCSLI), a non-profit association of over 1400 worldwide organizations, maintains RR projects for many measurement parameters, from dimensional to optical. The NCSLI Measurement Comparison Committee oversees those programs.¹

For RF power, a calibrated thermistor mount starts out at a "pivot lab," usually one with overall RR responsibility, then travels to many other reference labs to be measured, returning to the pivot lab for closure of measured data. Such mobile comparisons are also carried out between National Laboratories of various countries as a routine procedure to assure international measurements at the highest level.

1. National Conference of Standards Laboratories, Measurement Comparison Committee, Suite 305B, 1800 30th St. Boulder, CO 80301.

2. M.P. Weidman, "Direct Comparison Transfer of Microwave Power Sensor Calibration," NIST Technical Note 1379, January, 1996.

3. NIST Special Publication 250; NIST Calibration Services. The latest up-to-date information on NIST calibration services is also maintained on the following website: www.ts.nist.gov/ts/htdocs/230/233/calibrations/index.htm

Microwave power measurement calibration services are available from many National Laboratories around the world, such as the NPL in the United Kingdom and PTB in Germany. Calibration service organizations are numerous too, with names like NAMAS in the United Kingdom.

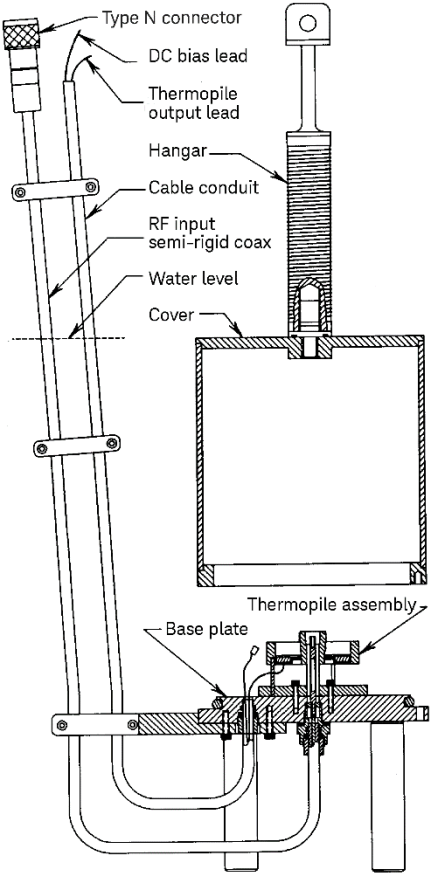

Figure 3-2. Schematic cross-section of the NIST coaxial microcalorimeter at Boulder, CO. The entire sensor configuration is maintained under a water bath with a highly-stable temperature so that RF to DC substitutions may be made precisely.

The theory and practice of sensor calibration

Every power sensor, even the DC-substitution types such as thermistor types, require data correction for frequency response, temperature effects, substitution errors from RF to DC, or conversion and heating effects. The ultimate power standard is usually a microcalorimeter at a NMI, for example, in the United States, the NIST, as described previously. By carefully transferring the microcalorimeter power measurement data to secondary standard sensors, the NMIs can supply comparison services to customer sensors. These are transportable between the NMI and their organization's primary standards labs, and in turn, down to the production line or field measurement.

The comparison process varies according to the frequency range required. Usually the comparison equipment is based on the power splitter technique, to be described below in Figure 3-3. The popularity of the power splitter technique is that they operate all the way from DC, thus including desired calibration frequencies such as 100 kHz. They offer ultra low impedance match at their output, such that devices-under-test (sensors) see a relatively low SWR looking back into the source.

The basic idea is to run a frequency response on a standard sensor applied to the test port of the splitter and capture that power data in a computer data base. Then the sensor to be calibrated is applied to the same port, and another frequency run made with a new data capture. The standard sensor has power data which is traceable to the company's primary lab, and, in turn, further up to the national standard. Thus this data with known uncertainties may be transferred to the sensor under test.

Modern techniques take the accuracy another step up by measuring the complex impedance of the system's test port (splitter), as well as the impedance of the sensor under test. A network analyzer usually measures both, and the complex reflection coefficient data stored in the computer data base. This impedance then is used to correct the power transfer equation for each calibration frequency.

The impedance correction routines are of course applied to the test run of the standard sensor as well as the sensor under test. Some sensor calibrators utilize a system which combines a network analyzer with a configuration that furnishes the test power for the sensor. While this alleviates some connecting/disconnecting, it does not optimize the throughput of the systems because the network analyzer has to idle while the power splitter frequency run is made. So separating the two measurement functions is normally prudent. Each metrology laboratory tasked with sensor calibration workloads needs to do their own analysis.

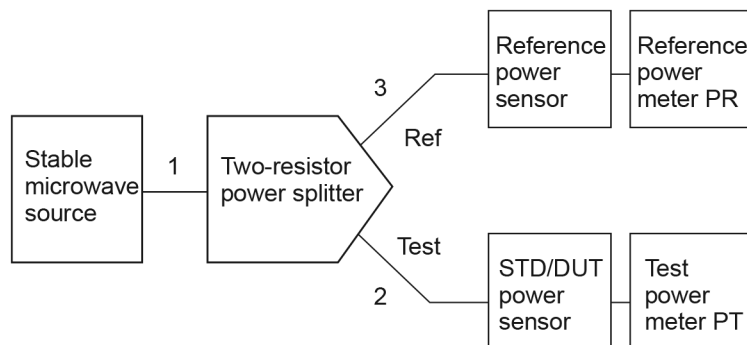

Figure 3-3. A two-resistor power splitter serves as a very broadband method for calibrating power sensors.

Note: Technical descriptions of sensor calibration and traceability here include some mathematical concepts on scattering parameters and signal flowgraphs, which are explained in detail in *Fundamentals Part 3*.

Some measurement considerations for power sensor comparisons

For metrology users involved in the acquisition, routine calibration, or roundrobin comparison processes for power sensors, an overview might be useful. Since thermistor sensors are most often used as the transfer reference, the processes will be discussed in this section.

Typical sensor comparison system

The most common setup for measuring the effective efficiency or calibration factor of a sensor under test (DUT) is known as the power ratio method, as shown in Figure 3-3.¹ The setup consists of a three-port power splitter that is usually a two-resistor design. A reference detector is connected to port 3 of the power splitter, and the DUT and standard (STD) sensors are alternately connected to port 2 of the power splitter. Other types of three-ports can also be used such as directional couplers and power dividers.

The signal source that is connected to port 1 must be stable with time. The effects of signal source power variations can be reduced by simultaneously measuring the power at the reference and the DUT or the reference and the STD. This equipment setup is a variation of that used by the Keysight 11760S power sensor calibration system, (circa 1990), now retired.

For coaxial sensors, the two-resistor power splitters are typically very broadband and can be used down to DC. Because the internal signal-split common point is effectively maintained at zero impedance by the action of the power split ratio computation, Γ_g for a well balanced two-resistor power splitter is approximately zero. Unfortunately, at the higher frequencies, two-resistor power splitters are typically not as well balanced and Γ_g can be 0.1 or larger. The classic article describing coaxial splitter theory and practice is, "Understanding Microwave Power Splitters."² For waveguide sensors, similar signal splitters are built up, usually with waveguide directional couplers.

In the calibration process, both the DUT and STD sensors are first measured for their complex input reflection coefficients with a network analyzer. The reference sensor is usually a sensor similar to the type of sensor under calibration, although any sensor/ meter will suffice if it covers the desired frequency range.

The equivalent source mismatch of the coaxial splitter (port 2) is determined by measuring the splitter's scattering parameters with a network analyzer and using that data in Equation 3-1. That impedance data now represents the Γ_g . Measurement of scattering parameters is described in *Fundamentals Part 3*.

$$\Gamma_g = S_{22} - \frac{S_{21}S_{32}}{S_{31}}$$

(Equation 3-1)

1. M.P. Weidman, "Direct Comparison Transfer of Microwave Power Sensor Calibration," NIST Technical Note 1379, January, 1996.
2. Russell A. Johnson, "Understanding Microwave Power Splitters," Microwave Journal, Dec 1975.

There is also a direct-calibration method for determining Γ_g , that is used at NIST.¹ Although this method requires some external software to set it up, it is easy to use once it is up and running.

Next, the power meter data for the standard sensor and reference sensor are measured across the frequency range, followed by the DUT and reference sensor. It should be noted that there might be two different power meters used for the “test” meter, since a Keysight 432 meter would be used if the STD sensor was a thermistor, while a Keysight EPM meter would be used to read the power data for a thermocouple DUT sensor. Then these test power meter data are combined with the appropriate reflection coefficients according to the equation:

$$Kb = Ks \frac{PT_{dut}PR_{std} |1 - \Gamma_g \Gamma_d|^2}{PT_{std}PR_{dut} |1 - \Gamma_g \Gamma_s|^2}$$

(Equation 3-2)

Where:

K_b = cal factor of DUT sensor

K_s = cal factor of STD sensor

PT_{dut} = reading of test power meter with DUT sensor

PT_{std} = reading of test power meter with STD sensor

PR_{std} = reading of reference power meter when STD measured

PR_{dut} = reading of reference power meter when DUT measured

Γ_g = equivalent generator reflection coefficient $\rho_g = |\Gamma_g|$

Γ_d = reflection coefficient of DUT sensor $\rho_d = |\Gamma_d|$

Γ_s = reflection coefficient of STD sensor $\rho_s = |\Gamma_s|$

A 75 Ω splitter might be substituted for the more common 50 Ω splitter if the DUT sensor is a 75 Ω unit.

Finally, it should also be remembered that the effective efficiency and calibration factor of thermocouple and diode sensors do not have any absolute power reference, compared to a thermistor sensor. Instead, they depend on their 50 MHz reference source to set the calibration level. This is reflected by the Equation 3-2, which is simply a ratio.

1. R.F. Juroshek, John R., “A direct calibration method for measuring equivalent source mismatch,” Microwave Journal, October 1997, pp 106-118.

Thermistors as power transfer standards

For special use as transfer standards, the U.S. NIST, accepts thermistor mounts, both coaxial and waveguide, to transfer power parameters such as calibration factor, effective efficiency and reflection coefficient in their measurement services program. To provide those services below 100 MHz, NIST instructions require sensors specially designed for that performance.

One example of a special power calibration transfer is the one required to precisely calibrate the internal 50 MHz, 1 mW power standard in the Keysight power meters, which use a family of thermocouples or diode sensors. That internal power reference is needed since those sensors do not use the power substitution technique. For standardizing the 50 MHz power reference, a specially-modified Keysight 478A thermistor sensor with a larger RF coupling capacitor is available for operation from 1 MHz to 1 GHz. It is designated the 478A Special Option H55 and features an SWR of 1.35 over its range. For an even lower transfer uncertainty at 50 MHz, the 478A Special Option H55 can be selected for 1.05 SWR at 50 MHz. This selected model is designated the 478A Special Option H75.

478A Special Option H76 thermistor sensor is the H75 sensor that has been specially calibrated in the Keysight Microwave Standards Lab with a 50 MHz power reference traceable to NIST. Other coaxial and waveguide thermistor sensors are available for metrology use.

NIST sensor calibration services while mainly focused on DC-substitution technology using thermistor sensors ran out of frequency range at the upper limit of coaxial thermistors. NIST now offers calibration service for thermocouple sensors that reach 50 GHz.¹

Other DC-substitution meters

Other self-balancing power meters can also be used to drive thermistor sensors for measurement of power. In particular, the NIST Type 4 power meter, designed by the NIST for high-accuracy measurement of microwave power is well suited for the purpose. The Type 4 meter uses automatic balancing, along with a four-terminal connection to the thermistor sensor and external high precision DC voltage instrumentation. This permits lower uncertainty than commercial power meters are designed to accomplish.

1. NIST Special Publication 250; NIST Calibration Services. The latest up-to-date information on NIST calibration services is also maintained on the following website: www.ts.nist.gov/ts/htdocs/230/233/calibrations/index.htm

Peak power sensor calibration traceability

For years, ultimate power sensor traceability to national standards was limited to average power parameters. One can understand this because the microcalorimeter-based standard inherently depends on a long-term power absorption at very stable signal conditions. With the very long time-constants of microcalorimeters, the process calls for characterizing the power transfer for a long averaging period.

The average power of real-world signal formats is seldom the only parameter of interest. New wireless communications signals combine multiplexed channels that look like noise power with pulsed formats for time-share. The EDGE signal of Figure 2-1 is a good example. Naturally, manufacturers and users of peak power sensors would be requesting traceability for such special formats.

As of this writing, the National Physical Laboratory (NPL) in the UK has sponsored a research program into the complexities of characterizing peak power sensors. These are not trivial considerations because bandwidth of the instrumentation and the linearity of the sensor both contribute to computed errors. In particular, the linearity of peak- detecting sensors at low power levels was generally poorer than CW sensors. Peak sensors also reveal more nonlinearities in the higher power areas where corrections are applied to the detection characteristic. Range-switching transitions can lead to minor data discontinuities. These all can lead to uncertainties in computed data such as peak-to-average power and power statistics which are required for CDMA systems like cdmaOne and W-CDMA.

The NPL calibration system work was validated against the sampling oscilloscope measurements that validated the waveform characteristics of the pulsed RF signal. This is important because of the generally limited bandwidth of the peak power instrumentation associated with pulsed or complex-modulation power signals. Of course, the ultimate power standard was still a CW sensor, which served as the traceable link to the NPL power standard.

NPL's peak power project has involved various popular frequency bands and power levels. It is suggested that potential users of peak power sensor calibration services make direct contact with the NPL website.¹

In a summary presentation for peak power uncertainty budget for a DECT signal (1900 MHz region), the total was computed at a 3.2% uncertainty for 95% confidence. The overall expanded uncertainty included sensor efficiency, power ratio, standard sensor mismatch, DUT sensor mismatch and repeatability, plus the CW—pulse transfer.

1. Website for National Physics Laboratory, UK, pulsed power information (note caps): www.npl.co.uk/measurement_services/ms_EG.html#EG04

Network analyzer source method

For production situations, it is possible to modify an automatic RF/microwave network analyzer to serve as the test signal source, in addition to its primary duty measuring impedance. The modification is not a trivial process, however, due to the fact that the signal paths inside the analyzer test set sometimes do not provide adequate power output to the test sensor because of directional coupler roll off.

NIST six-port calibration system

For its calibration services of coaxial, waveguide, and power detectors, the NIST uses a number of different methods to calibrate power detectors. The primary standards are calibrated in either coaxial or waveguide calorimeters.^{1, 2} However, these measurements are slow and require specially built detectors that have the proper thermal characteristics for calorimetric measurements. For that reason the NIST calorimeters have historically been used to calibrate standards only for internal NIST use.

The calibration of detectors for NIST's customers is usually done on either the dual six-port network analyzer or with a two-resistor power splitter setup such as the one described above.² While different in appearance, both of these methods basically use the same principles and therefore provide similar results and similar uncertainties.

The advantage of the dual six-ports is that they can measure Γ_g , Γ_s , and Γ_d , and the power ratios in Equation 3-2 at the same time. The two-resistor power splitter setup requires two independent measurement steps since Γ_g , Γ_s , and Γ_d are measured on a vector network analyzer prior to the measurement of the power ratios. The disadvantage of the dual six-ports is that the NIST systems typically use four different systems to cover the 10 MHz to 50 GHz frequency band. The advantage of the two-resistor power splitter is its wide bandwidth and DC-50 GHz power splitters are currently commercially available.

1. Allen, J.W., F.R. Clague, N.T. Larsen, and W. P Weidman, "NIST microwave power standards in waveguide," NIST Technical Note 1511, U. S. Department of Commerce, February 1999.

2. Engen, G.F., "Application of an arbitrary 6-port junction to power-measurement problems," IEEE Transactions on Instrumentation and Measurement, Vol IM-21, November 1972, pp 470-474.

General references

- R.W. Beatty, "Intrinsic Attenuation," IEEE Trans. on Microwave Theory and Techniques, Vol. 11, No. 3 (May, 1963) 179-182.
- R.W. Beatty, "Insertion Loss Concepts," Proc. of the IEEE. Vol. 52, No. 6 (June, 1966) 663-671.
- S.F. Adam, "Microwave Theory & Applications," Prentice-Hall, 1969.
- C.G. Montgomery, "Technique of Microwave Measurements," Massachusetts Institute of Technology, Radiation Laboratory Series, Vol. 11. McGraw-Hill, Inc., 1948.
- Mason and Zimmerman. "Electronic Circuits, Signals and Systems," John Wiley and Sons, Inc., 1960.
- Fantom, A, "Radio Frequency & Microwave Power Measurements," Peter Peregrinus Ltd, 1990
- "IEEE Standard Application Guide for Bolometric Power Meters," IEEE Std. 470-1972.
- "IEEE Standard for Electrothermic Power Meters," IEEE Std. 544-1976.20

Glossary and List of Symbols

This glossary is applicable to all four parts of the Fundamentals of RF and Microwave Power Measurements application note series.

ADC	Analog-digital converter
a_g	Incident wave upon a generator
ANSI	American National Standards Institute
AM	Amplitude modulation
a_l	Incident wave upon a load
b_g	Emerging wave from a generator
b_l	Reflected wave from a load
BPSK	Binary phase-shift keyed
b_s	Generated wave of a source
C_b	Bypass capacitance
C_c	Coupling capacitance
CDMA	Code-Division-Multiple-Access
C_o	Diode junction capacitance
CW	Continuous wave
C, C1, C2	Capacitors
dB	Decibel
dBm	Decibels referenced to 1 mW
D	Power meter drift
DECT	Digital Enhanced Cordless Telecommunications
DSP	Digital signal processor
e	Instantaneous voltage
EDGE	Enhanced Data rates for GSM Evolution (wireless standard)

emf	Electromotive force
e_p	Peak voltage
E_{rms}	Root mean-square of a voltage waveform
e_s	Source voltage
FDM	Frequency-division-multiplex
FET	Field effect transistor
f_m	Maximum modulation frequency component
f_r	Repetition frequency
FM	Frequency modulation
GaAs	Gallium arsenide
GPIO	General purpose interface bus
GSM	Groupe Spéciale Mobile, a wireless standard sometimes read as Global System for Mobile communication
i	Instantaneous current
i	Instrumentation uncertainty
i_l	Load current
i_p	Peak current
I_{rms}	Root mean-square of a current waveform
I_s	Diode saturation current
IS-95A	Wireless communication standard
ISO	International Standards Organization
K	Boltzmann's constant
K_b	Calibration factor
K_c	Sensor cal factor at cal frequency
L	Inductance
L_w	Wire lead inductance
m	Power meter magnification (gain)
m_i	Instrument magnification uncertainty
MMIC	Microwave monolithic integrated circuit
M_u	Gain due to mismatch between unknown generator and sensor
M_{uc}	Gain due to mismatch between sensor and cal source
n	A diode correction constant
N	Power meter noise
NADC	North American Digital Cellular
NAMAS	National Measurement Accreditation Scheme (UK)
NBS	National Bureau of Standards (now NIST)
NCSLI	National Conference of Standards Laboratories International
NIST	U.S. National Institute of Standards & Technology (formerly NBS)
NMI	National Measurement Institute (such as NIST or NPL or PTB, etc)
NPL	National Physics Laboratory (UK)
P	Product of voltage and current
P	Power
P_{av}	Available generator power
P_{avg}	Average power

P_{cal}	Power delivered to Z_o load by meter cal source
P_d	Dissipated power
P_{fs}	Power at full scale
P_{gt}	Net power transferred to load from generator
P_{gzo}	Power delivered to Z_o load from generator
P_i	Incident power
P_m	Meter indication of power
P_{mc}	Power level indicated during calibration
P_p	Pulse power
P_r	Reflected power
P_{ref}	Reference power
P_{rf}	Radio frequency power
P_{sub}	Substituted power, dc or low frequency equivalent of an RF power
PDB	Planar-doped-barrier (diode)
PTB	Physikalisch-Technische Bundesanstalt (Germany)
P_l	Power sensor linearity
q	Charge of electron
QAM	Quadrature-amplitude-modulation
QPSK	Quadrature-phase-shift-keyed (digital modulation)
R	Resistance
RF	Radio frequency
RSS	Root-sum-of-the-squares
R_b	Bulk resistance of silicon
R_c	Resistance of compensating thermistor
R_d	Resistance of detecting thermistor
R_o	Diode origin resistance
R, R_1 , R_2 , R_L	Resistor
RR	Round robin
R_s	Source resistance
R_t	Thermistor resistance
SWR ¹	Voltage standing wave ratio
SI	International System of Units, time as a variable
T	Temperature in Kelvins
T	Time lapse
TDMA	Time-Division-Multiple-Access
T_o	Period of a waveform
T_l	Period of the lowest frequency
T_r	Period of the repetition frequency
Time-gated	Time window for power measurement
u	Standard uncertainty
U	Expanded uncertainty (for example catalog spec)

1. Due to infrequent use of the term power standing wave ratio, common usage in the U.S.A. has shortened VSWR to SWR. Some parts of the world continue to use VSWR to refer to voltage standing wave ratio.

v	Voltage across a load
v_o	Output voltage
V_0, V_1, V_2, V_T	Voltages
V_c	Voltage driving the compensating bridge
V_h	Peltier emf at a hot junction
V_{rf}	Voltage driving the rf thermistor bridge
V_{rfo}	Voltage driving the rf thermistor bridge when no rf power is applied
W	Watt
Z	Load impedance
Z_c	Power meter zero carryover value
Z_g	Generator impedance
Z_o	Reference impedance
Z_r	Reference impedance
Z_s	Power meter zero set value
$\pi/8$ 8PSK	$\pi/8$ shifted, 8-phase-shift-keyed (digital modulation)
α	q/nKT
Γ_g	Complex reflection coefficient looking back into a generator
Γ_l	Complex reflection coefficient of a load
η_e	Effective efficiency
ρ_l	Reflection coefficient magnitude of a load
ρ_g	Reflection coefficient magnitude of a generator
τ	Pulse width
Φ	Phase angle between a sinusoidal waveform and a reference waveform
Φ_g	Reflection coefficient angle of a generator
Φ_l	Reflection coefficient angle of a load
Ω	Ohms
3G	Third-generation wireless systems
8-PSK	8 phase-shift keyed (digital modulation)
64-QAM	64 quadrature-amplitude-modulation

This document was formerly known as Application Note 1449-1.

For more information on Keysight Technologies' products, applications, or services, please visit: www.keysight.com



This information is subject to change without notice. © Keysight Technologies, 2017 - 2022, Published in USA, August 15, 2022, 5988-9213EN