



## **User Manual**

60 V Common Mode Probes

DL02-HCM

DL05-HCM

DL10-HCM



## **60 V Common Mode Probes User Manual**

© 2023 Teledyne LeCroy, Inc. All rights reserved.

Unauthorized duplication of Teledyne LeCroy documentation materials other than for internal sales and distribution purposes is strictly prohibited. However, clients are encouraged to duplicate and distribute Teledyne LeCroy documentation for their own internal educational purposes.

Teledyne LeCroy is a trademark of Teledyne LeCroy, Inc. Other product or brand names are trademarks or requested trademarks of their respective holders. Information in this publication supersedes all earlier versions. Specifications are subject to change without notice.

dlxx-hcm-user-manual-eng\_05apr23.pdf  
April, 2023

# Contents

Introduction .....	1
Compatibility .....	1
Required Firmware .....	1
Probe Components.....	2
Specifications .....	5
Safety .....	16
Precautions .....	16
Safe Operating Environment.....	17
Probe Handling.....	17
Operation .....	18
Amplifier .....	18
Freehand Probe Holder.....	19
Connecting Tips .....	20
Using the PCF-200 Deskew Fixture .....	25
Operating from the Oscilloscope .....	26
Maintenance .....	29
Cleaning.....	29
Calibration Interval.....	29
Service Strategy .....	29
Replacement Parts .....	29
Returning a Product for Service .....	30
Performance Verification Procedure.....	31
Required Equipment.....	31
Preliminary Set Up .....	33
Functional Check .....	33
Verification Procedure .....	33
DL____-HCM Test Record .....	38
Reference.....	39

---

## **60 V Common Mode Probes**

---

Certifications .....	39
Technical Support .....	40
Warranty.....	40

## **Introduction**

The 60 V Common Mode Differential Probes (DLxx-HCM) offer 60 V of common mode and 80 V differential input range with up to 1 GHz of bandwidth, making them the ideal probe for lower voltage GaN power conversion measurements.

The Common Mode Rejection Ratio (CMRR) for the probes is exceptional to very high frequencies. This provides for the best measurement performance when measuring very fast slew rate (high dV/dt) PWM signals typical of GaN devices and systems. Exceptional CMRR, combined with low probe noise and high offset capability, makes the probes capable of measuring very small control signals floating on high common mode voltages.

The DLxx-HCM probes are calibrated for high-precision measurements to within 0.5% at DC and 0.1 dB flatness from DC to 100 MHz. This ensures high accuracy top and base voltage level measurement of pulse-width modulated signals. The Precision Gain Calibration capability furthers measurement precision by improving the gain accuracy and removing small offset drifts from the measurement configuration.

Equipped with a wide variety of standard tips, the 60 V Common Mode Differential Probes provide the perfect combination of high performance and flexibility for connecting to any device under test. An optional accessory kit and high temperature solder-in tip are available for further connectivity options.

## **Compatibility**

DLxx-HCM probes are compatible with Teledyne LeCroy oscilloscopes equipped with the ProBus interface running Windows® 10 Pro, Windows 7 Pro or Windows CE operating systems. See our website for all compatible oscilloscope models.

## **Required Firmware**

Proper functioning of the probes requires these minimum versions of MAUI® firmware to be installed on the oscilloscope:

- Version 9.3.x.x for DL05-HCM and DL10-HCM
- Version 10.3.x.x for DL02-HCM

# 60 V Common Mode Differential Probes

## Probe Components

The 60 V Common Mode Differential Probes consist of an amplifier and a selection of standard leads and tips. Optional accessories are available for purchase separately.

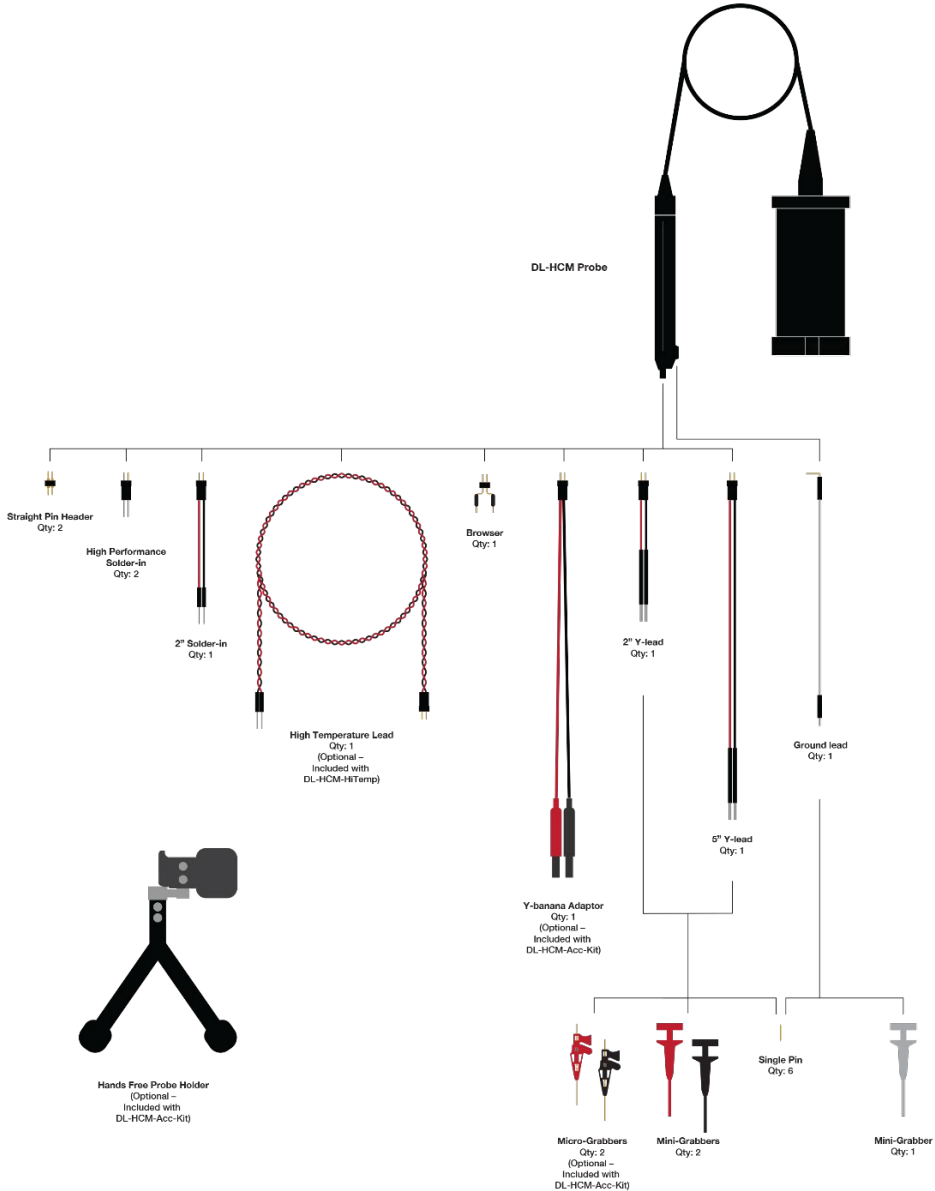

## Standard Accessories

The probes are delivered with the following standard accessories.

Item	Description	QTY DL05 DL10	QTY DL02
<b>Browser Tip</b>	Attaches to the amplifier for hand-held browsing. Combines high performance with quick access to many probing points.	1	1
<b>2" Solder-in Tip</b>	Can be soldered directly to the test points for a secure probe connection. Two-inch long leads give more flexibility in connecting to hard-to-reach test points.	1	0
<b>High Performance Solder-in Tip</b>	Because of their small size, these tips provide the maximum signal fidelity at the highest frequency response. They are soldered to the test points like the 2" solder-in tips.	2	0
<b>2" Y-lead Socket</b>	Used to probe differential signals that are far apart on the board. Can be connected directly over pins, used with single pins inserted, or with grabbers attached to connect to very tightly spaced points.	1	0
<b>5" Y-lead Socket</b>	Same as above with five-inch long leads. Could be used to extend into spaces where it is difficult to place the amplifier.	1	1
<b>Mini-Grabbers</b>	Can be used to connect to very tightly spaced pins. Always attach grabbers to a Y-lead socket.	3	0
<b>Straight Pin Header</b>	Used to connect to female receptacles. Pins have a fixed spacing of 2.54 mm (0.1 inch).	2	2
<b>Single Pin</b>	Fits into either socket of the Y-leads or the ground lead to make contact where there is no pin on the board.	6	6
<b>Ground Lead</b>	Bendable, socket-tipped ground lead can be used alone, or with the single pin or grabbers inserted for probing ground planes.	1	1
<b>Storage Case</b>	Soft storage case.	1	1
<b>Accessory Tray</b>	Plastic insert for storage case.	1	1
<b>Certificate of Calibration</b>		1	1

## 60 V Common Mode Differential Probes

---

### ***Optional Accessories***

The following optional accessories may be purchased separately.

<b>Item</b>	<b>Description</b>	<b>Part Number</b>	<b>QTY</b>
<b>High Temperature Lead</b>	Can be used in controlled situations where the differential amplifier needs to be removed from an extreme temperature environment. Ideally suited for testing where the temperature can fluctuate from -40 °C to +125 °C, the 1-meter long lead provides an easy and robust connection to the circuit under test. It is designed to be soldered to the test board like the solder-in tips.	DL-HCM-Hi-Temp	1
<b>Deskew Fixture</b>	May be used to determine the effect of probe input loading on the DUT, for verification of the probe's response to the signal being measured, or as a convenient way to deskew probes or oscilloscope channels.	PCF-200	1
<b>DL-HCM Accessory Kit</b>	Includes the following items.	DL-HCM-Acc-Kit	
Freehand Probe Holder	Designed to keep weight on the probe tip while securing the position of the amplifier. It helps prevent loss of contact when the circuit under test is destabilized. The amplifier can be mounted horizontally or vertically in the Freehand.		1
Y-banana Adaptor	Used to connect banana tips delivered with other probe models to the DLxx-HCM probe.		1
Micro-Grabbers	Ideal for connecting to small IC legs or very tightly spaced pins. It is always used with a Y-lead.		2



## Specifications

Full specifications are on the product datasheet. Visit [teledynelecroy.com/probes](http://teledynelecroy.com/probes).

**Note:** Specifications are subject to change without notice.

	DL02-HCM	DL05-HCM	DL10-HCM
<b>Guaranteed Specifications</b>			
Bandwidth (without leads)	250 MHz	500 MHz	1 GHz
DC Gain Accuracy	± 0.5%	± 0.5%	± 0.5%
<b>Electrical Specifications</b>			
Differential Mode Range <sup>1</sup>	80 V (DC + Peak AC), 200 mV/div to 20 V/div		
Common Mode Range <sup>2</sup>	± 60 V (DC + Peak AC)		
Max. Input Voltage to Earth (either input to ground)	80 V (DC + peak AC), max 60 V DC		
Max. Safe Input Voltage <sup>3</sup>	28.28 Vrms or 60 V DC (referenced to ground)		
Vertical Sensitivity (Gain)	200 mV/div to 20 V/div		
Measurement Category (CAT) <sup>4</sup>	No rated measurement category		
Pollution Degree <sup>5</sup>	2		

1. This is the maximum voltage that can be applied between the + and - inputs without overloading the amplifier, which otherwise would result in clipping or distorting of the waveform measured by the oscilloscope.
2. This is the maximum voltage with respect to earth ground that can be applied to either input. Exceeding the common mode range can result in unpredictable measurements. Because common mode signal is normally rejected and not displayed, be careful to avoid accidentally exceeding the common mode range.
3. This is the maximum safe input voltage with respect to ground for hand-held use.
4. Per IEC/EN 61010-031:2015, the probe is not intended for measurements on circuits directly connected to the Mains supply.
5. Per IEC/EN 61010-031:2015, the probe is to be used only in an operating environment where normally only dry, non-conductive pollution occurs. Temporary conductivity caused by condensation should be expected.



**WARNING:** The probe is not intended for hand-held use above 60 VDC. Do not handle probe tips, leads or any part of the amplifier if there is any question as to whether DC bus voltages are greater than 60 V. Use stationary setup for measurements above 60 V.

## 60 V Common Mode Differential Probes

### Typical Bandwidth

Typical bandwidth probe only or with named tip.

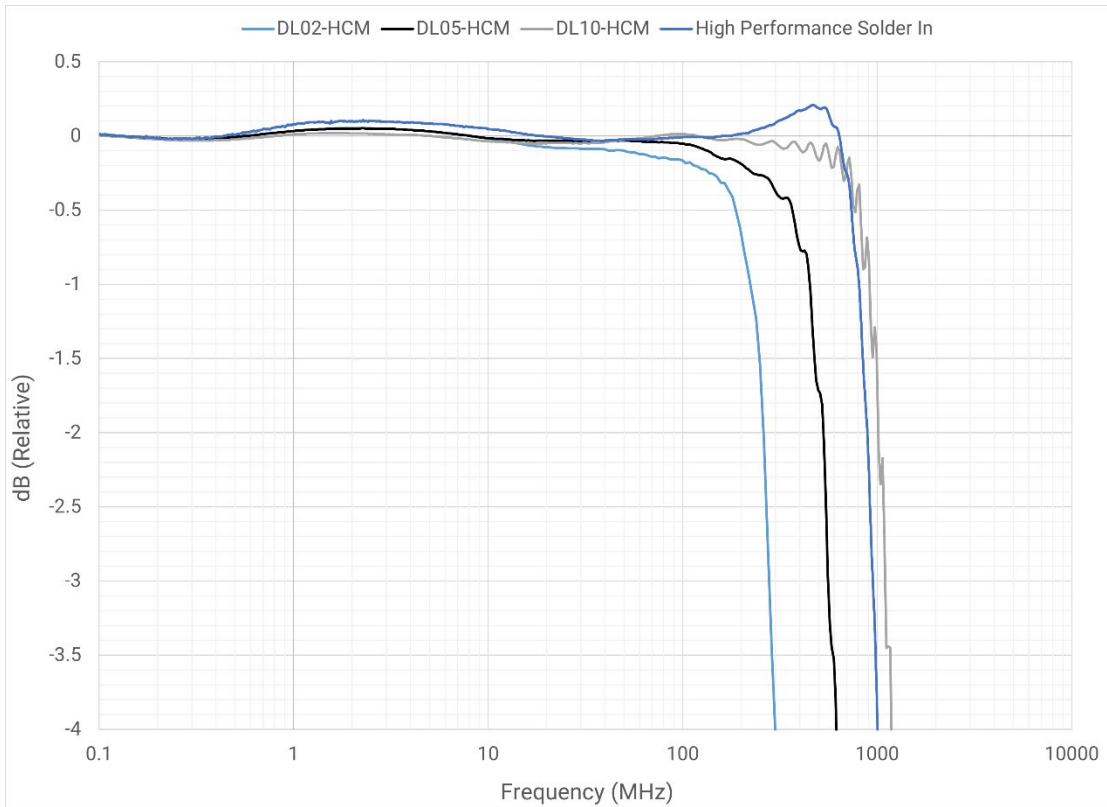

Typical Bandwidth (cont'd)

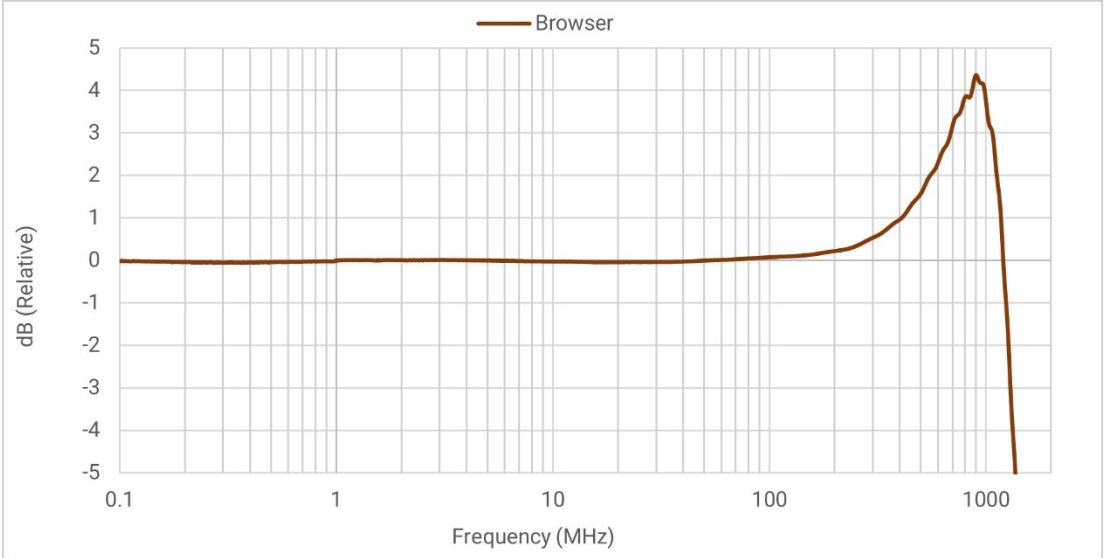
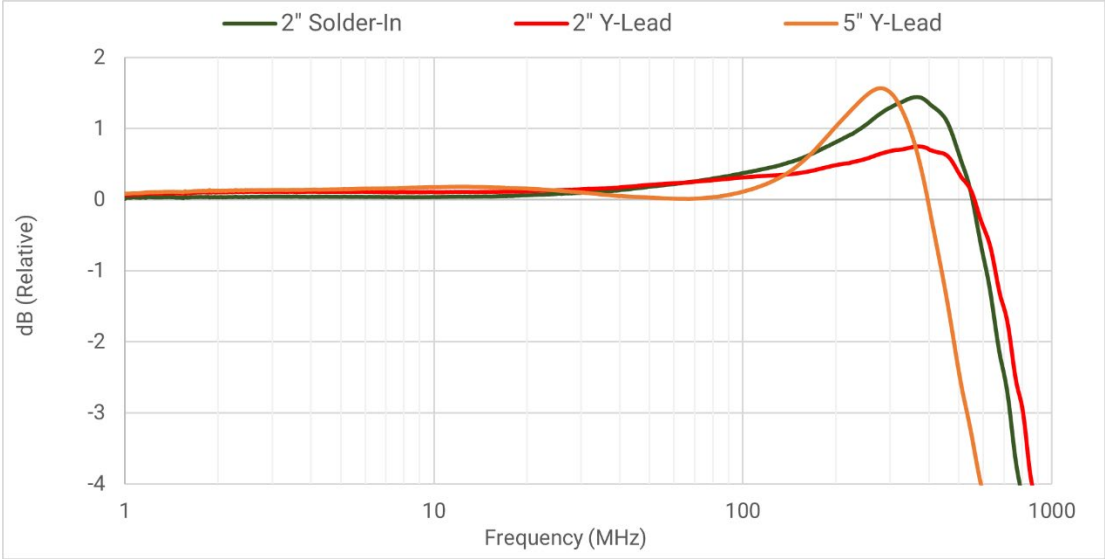

## 60 V Common Mode Differential Probes

### Typical Step Response

Typical step response to 1 V input, probe only or with named tip.

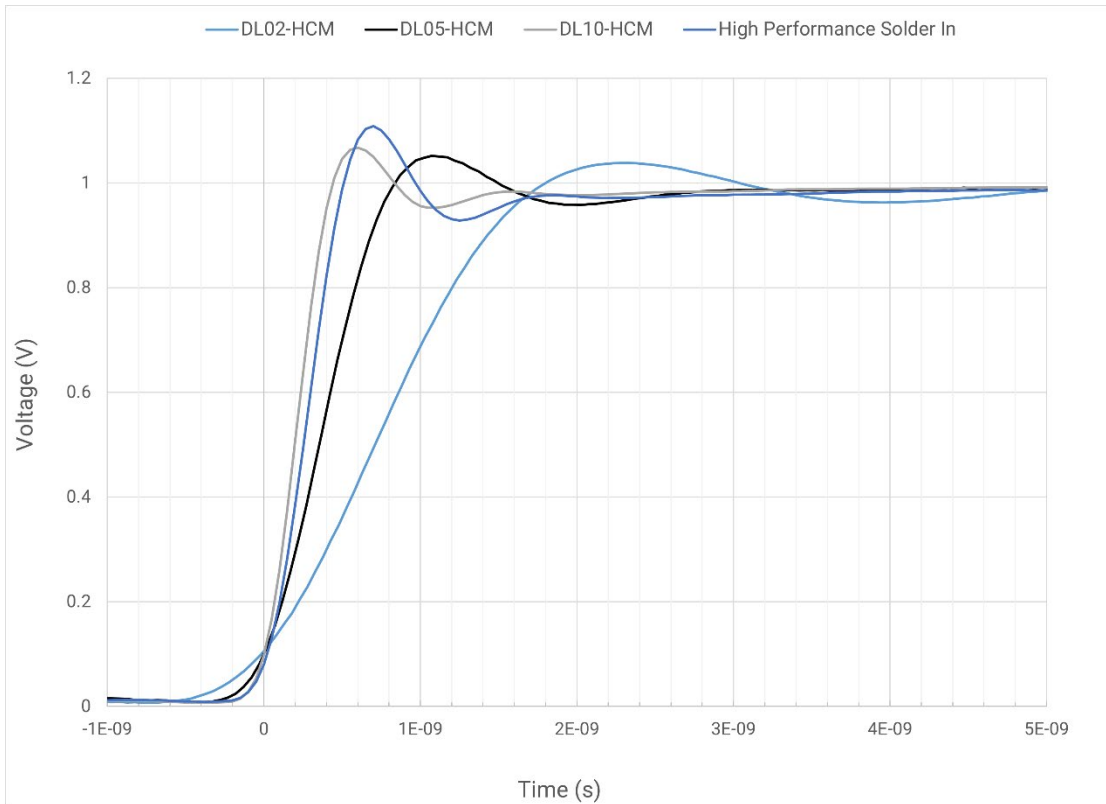

Typical Step Response (cont'd)

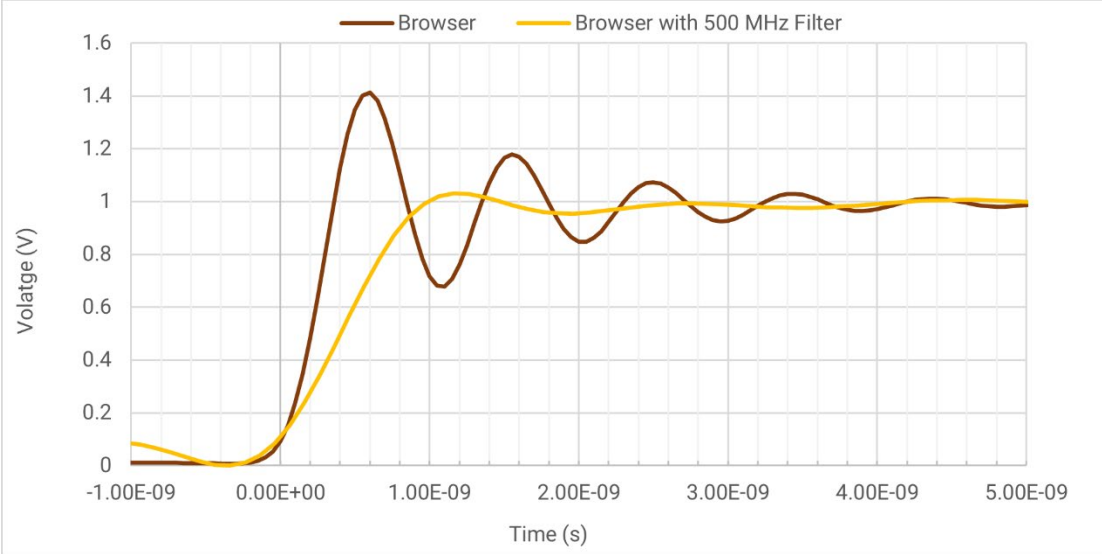
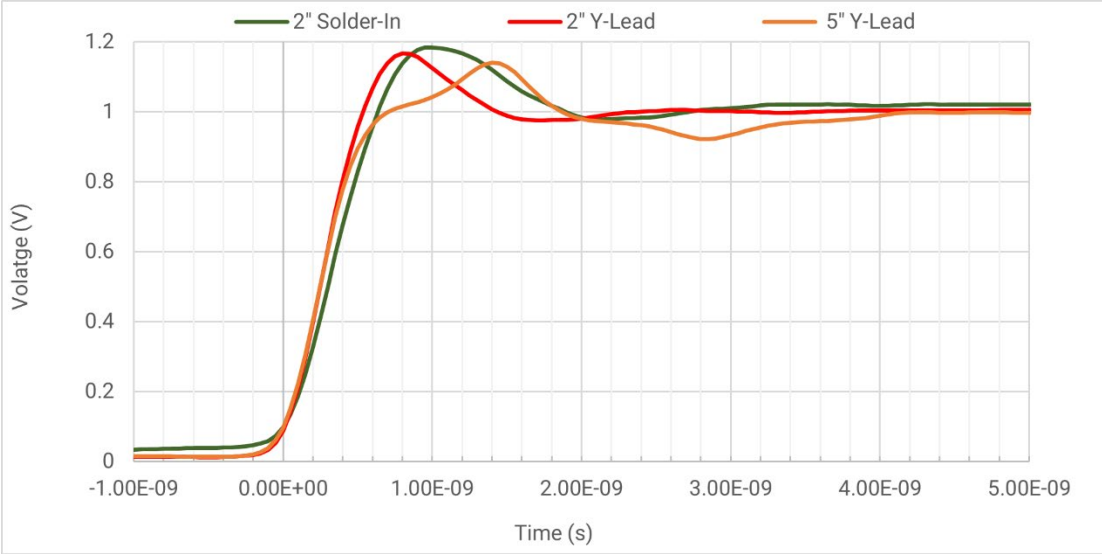

**Note:** Unless full bandwidth is required, we recommend applying a bandwidth filter when using the Browser to reduce peaking. The plot above shows the results.

## 60 V Common Mode Differential Probes

### Typical CMRR Performance

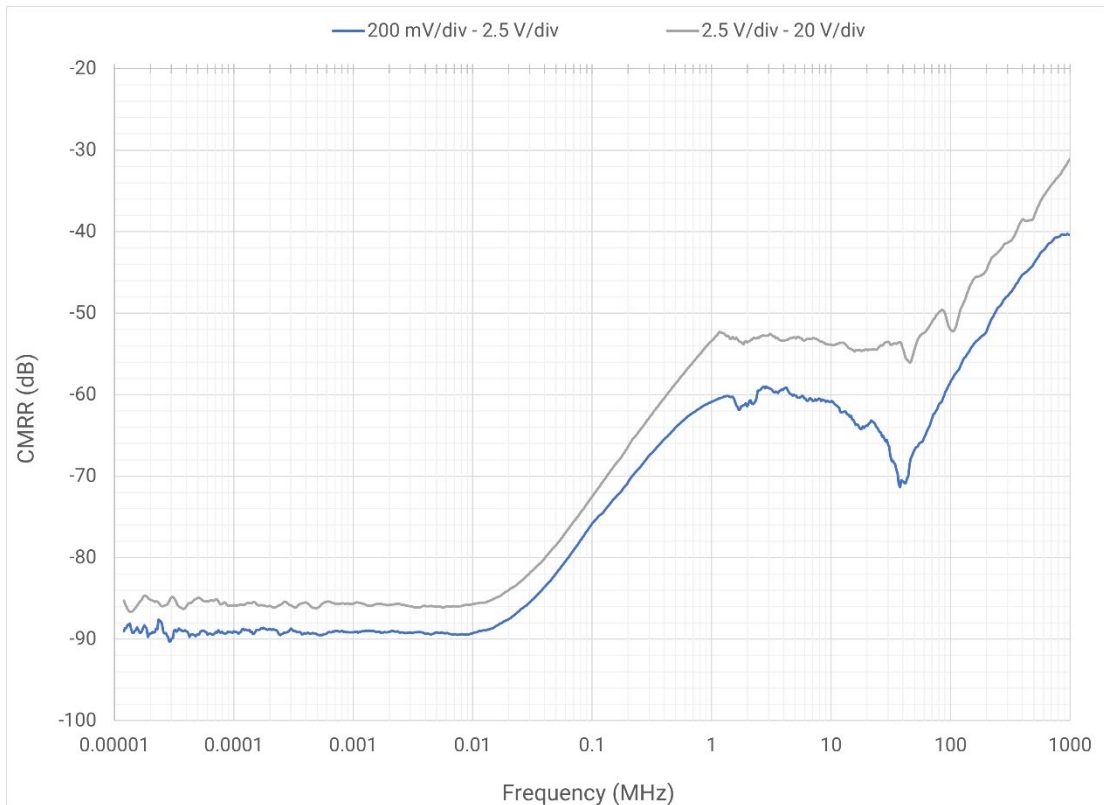

Differential probes sense the voltage difference that appears between the + and – inputs, referred to as the normal or **differential mode voltage**. The voltage component that is referenced to earth and is identical on both inputs is rejected by the amplifier. This is referred to as the **common mode voltage** and can be expressed:  $V_{cm} = (V_{+input} + V_{-input})/2$

The ideal differential probe/amplifier would sense and amplify only the differential mode voltage component and reject the entire common mode voltage component. Real differential amplifiers are not perfect, and a small portion of the common mode voltage component appears at the output.

**Common mode rejection ratio (CMRR)** is the measure of how much the amplifier rejects the common mode voltage component. CMRR is equal to the differential mode gain (or normal gain) divided by the common mode gain. Common mode gain is equal to the output voltage divided by the input voltage when both inputs are driven by only the common mode signal. CMRR can be expressed as a ratio (e.g., 10,000:1) or implicitly in dB (e.g., 80 dB). Higher

numbers indicate greater rejection (better performance).

The first order term determining the CMRR is the relative gain matching between the + and - input paths. You can obtain high CMRR values by precisely matching the input attenuators in a differential amplifier. The matching includes the DC attenuation and the capacitance which determines the AC attenuation. As the frequency of the common mode component increases, the effects of stray parasitic capacitance and inductance in determining the AC component become more pronounced. The CMRR becomes smaller as the frequency increases. Therefore, the CMRR is usually specified in a graph of CMRR versus common mode frequency.

The common mode frequency in the previous graph is assumed to be sinusoidal. In real life applications, the common mode signal is seldom a pure sine wave. Signals with pulse wave shapes contain frequency components much higher than the repetition rate may suggest. This makes it very difficult to predict actual performance in the application for CMRR-versus- frequency graphs.

### ***Differential Input Impedance***

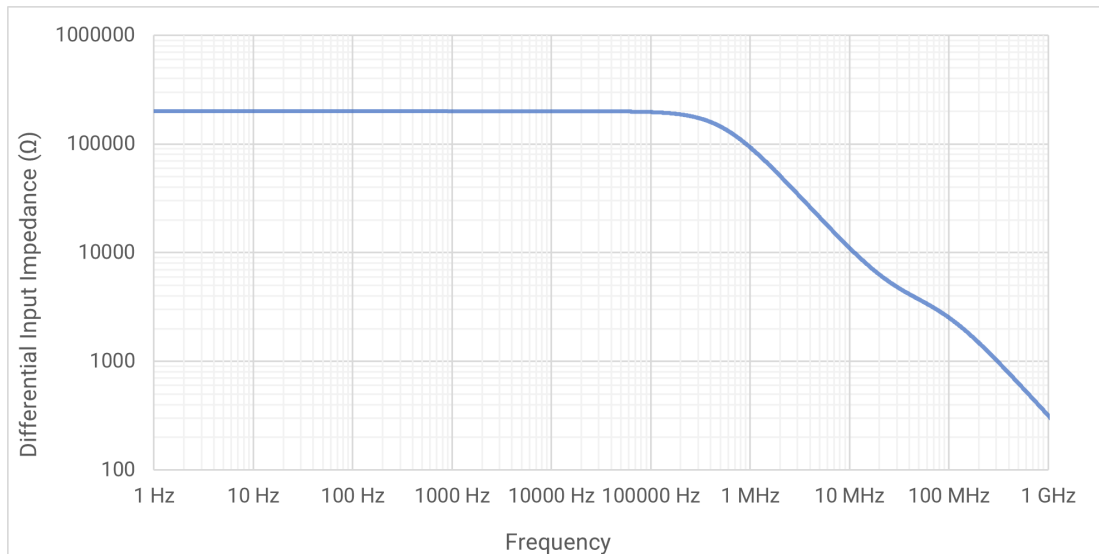

## 60 V Common Mode Differential Probes

---

### *Voltage vs. Frequency Derating*

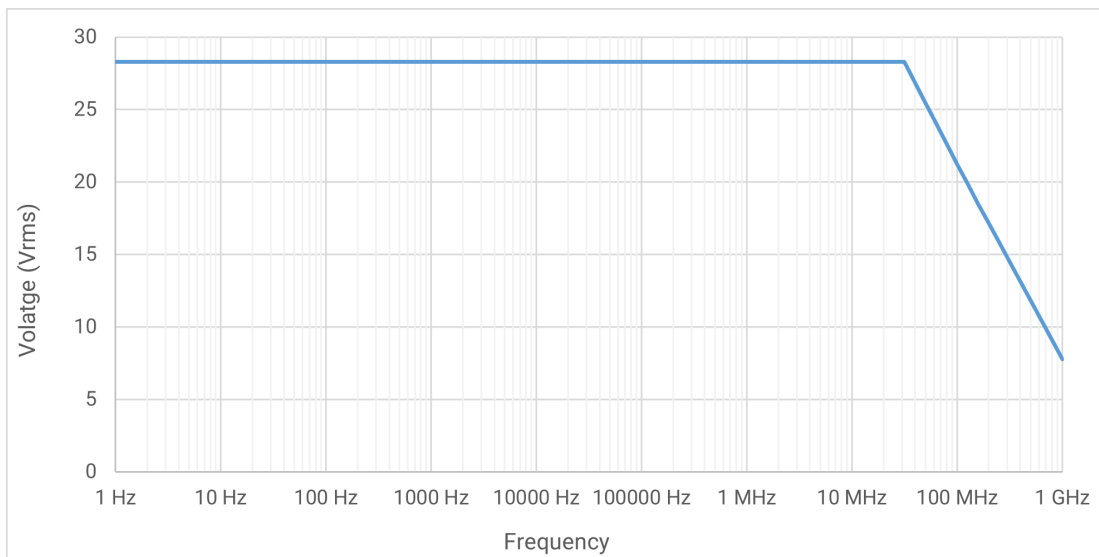



## Equivalent Circuits (Probe Loading)

### PROBE ONLY

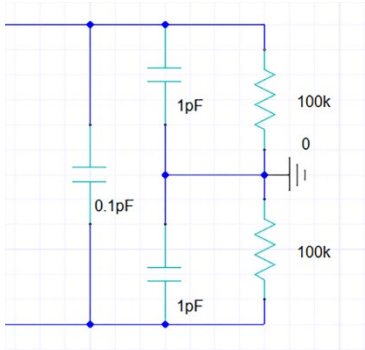

### BROWSER TIP

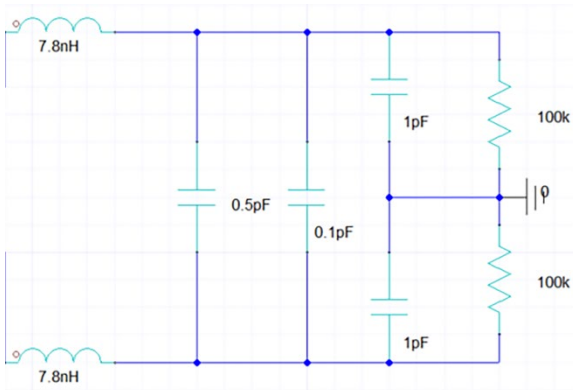

### 2" SOLDER-IN TIP

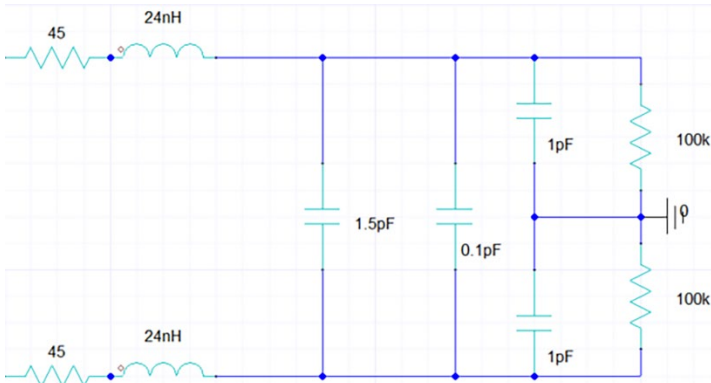

## 60 V Common Mode Differential Probes

### HIGH-PERFORMANCE SOLDER-IN TIP

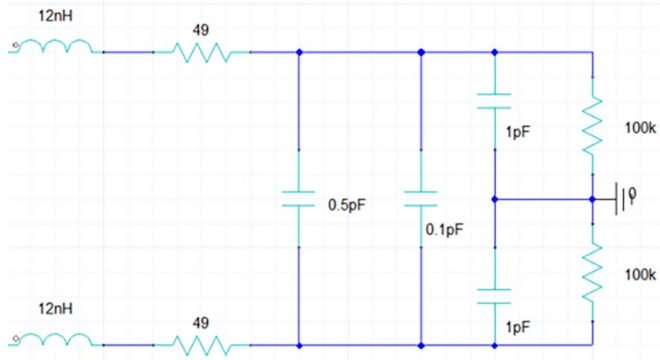

### 2" Y-LEAD

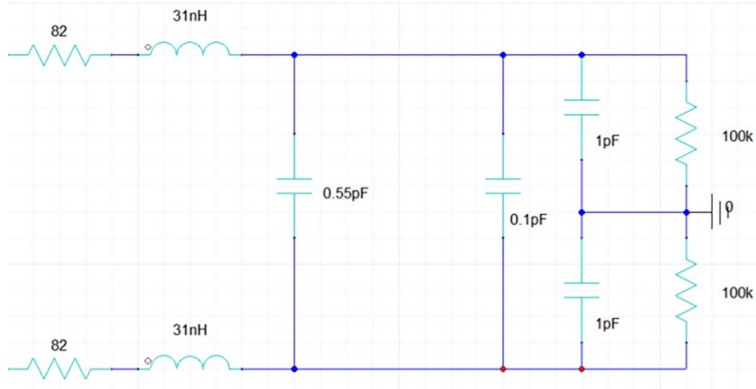

### 5" Y-LEAD

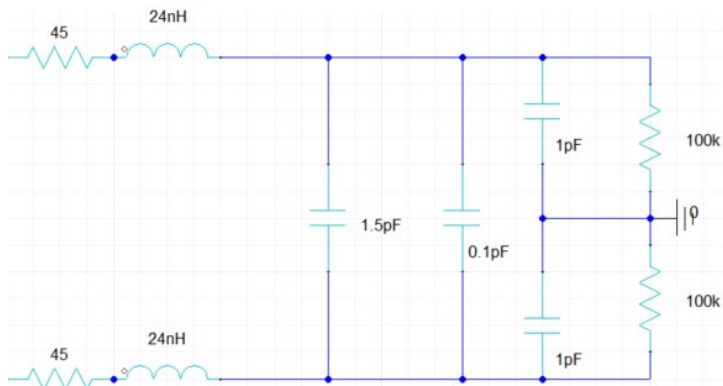

### HI-TEMP LEAD

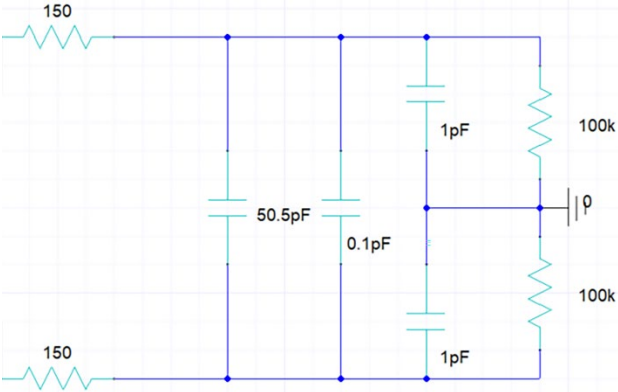

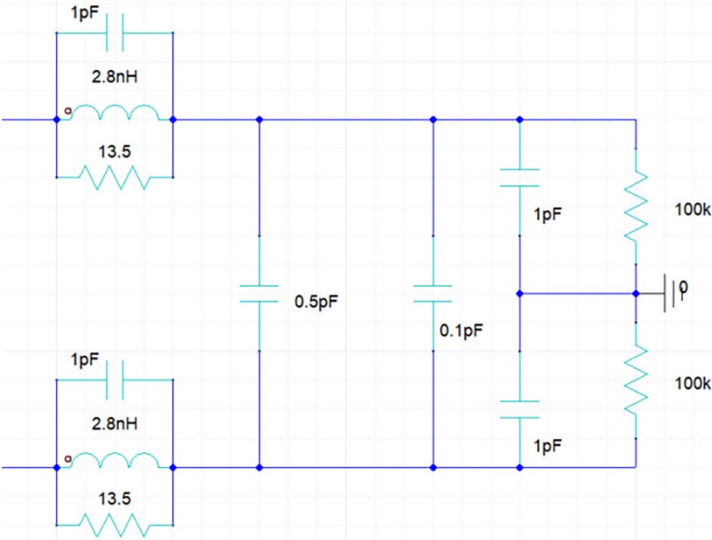

### STRAIGHT PIN HEADER



### Safety

To maintain the probe in a correct and safe condition, observe generally accepted safety procedures in addition to the precautions specified in this section. **The overall safety of any system incorporating this product is the responsibility of the assembler of the system.**

These symbols appear on the probe and accessories or in this manual to alert you to important safety considerations.

	<b>WARNING, HIGH VOLTAGE.</b> Risk of electric shock or burn.
	<b>CAUTION</b> of damage to probe or instrument, or <b>WARNING</b> of hazard to health. Attend to the accompanying information to protect against personal injury or damage. Do not proceed until conditions are fully understood and met.
	<b>ESD CAUTION.</b> Risk of Electrostatic Discharge (ESD) that can damage the probe or instrument if anti-static measures are not taken.

### Precautions



**WARNING.** To avoid personal injury or damage due to electric shock or fire:

**Do not handle probe tips, leads or any part of the amplifier if DC bus voltages are > 60 V.** Use stationary setup for measurements > 60V. If there is any question as to whether >60 V voltages are present in the circuit, exercise caution and **do not touch** these components.

**Do not use the probe for measurements on Mains circuits.** The probe does not have a CAT rating for use on circuits in Measurement Categories II, III or IV.

**Do not overload; observe all terminal ratings.** Do not apply any potential that exceeds the maximum rating of the probe and/or the probe accessory, whichever is less.

**Comply with the Voltage vs. Frequency derating curve.**

**Connect and disconnect properly.** Always connect the probe input lead to the probe accessories before connecting to a voltage source. Ensure the connections are secure before applying voltage. Do not disconnect leads or accessories from a live circuit.

**Keep the probe body and output cable away from the circuits being measured.** Only accessory tips are intended for contact with electrical sources.

**Use only accessories compatible with the probe and rated for the application.** Substituting other accessories than those specified in this manual may create a shock /burn hazard.

**Do not remove the probe's casing.** Touching exposed connections may result in electric shock or burn.



**CAUTION.** To prevent damage to the equipment:

**Use only as specified.** The probe is intended to be used only with compatible Teledyne LeCroy instruments. Use of the probe and/or the equipment it is connected to in a manner other than specified may impair the protection mechanisms.

**Do not bend cables excessively.**

**Use only within the operational environment listed.** Do not use in wet or explosive atmospheres.

**Keep product surfaces clean and dry.**

**Do not operate with suspected failures.** Before each use, inspect the probe and accessories for any damage such as tears or other defects in the probe body, cable jacket, accessories, etc. If any part is damaged, cease operation immediately and sequester the probe from inadvertent use.

## Safe Operating Environment

Temperature, operating	0 °C to 50 °C
Temperature, not operating	-40 °C to 70 °C
Relative Humidity, operating	5% to 90% RH (non-condensing) up to 30 °C decreasing linearly to 45% RH at 50 °C
Relative Humidity, not operating	5% to 95% RH (non-Condensing) 75% RH above 40 °C, 45% RH above 50 °C
Altitude	3000 m (9842 ft.) max.
Usage	Indoors

## Probe Handling

Probes are precision test instruments. Exercise care when handling and storing the probe. Avoid sharply bending or putting excessive strain on any cable or lead.



**ESD Sensitive:** The tips of the probe are sensitive to Electrostatic Discharge (ESD). Always follow anti-static procedures when using or handling the probe.



**CAUTION:** Store tips in the plastic protective storage case when not in use.

# Operation

## Amplifier

The amplifier forms the foundation of the probe. It is powered from the oscilloscope and in turn communicates to the oscilloscope its identifying characteristics. This ensures the oscilloscope channel is automatically set to the correct probe attenuation value.

On the top (label) side is an LED indicator that lights in the color of the channel to which the probe is connected. On the bottom is the ground lead input.

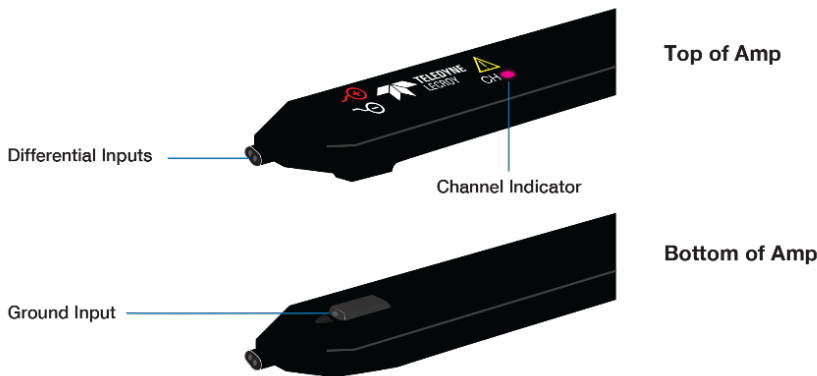

60 V common mode probes have been designed for use with Teledyne LeCroy oscilloscopes equipped with the ProBus interface. To connect to the instrument, press the amplifier connection box onto the oscilloscope's ProBus connector until you hear a click. The instrument will recognize the probe and:

- Display a *Cn* DLxx-HCM dialog with probe controls and status
- Set the oscilloscope input termination to 50 Ω
- Light the channel indicator on the amplifier to match the color of the channel

**Note:** For accurate measurements, connect the amplifier to the oscilloscope and wait until the "System is warming up." indicator disappears from the *Cn* DLxx-HCM dialog.

The amplifier may be seated directly over square pins on the board or used with any of the compatible tips. All tips (except for the straight pin, mini- and micro-grabbers) have a two-pin connector at one end that inserts into the differential inputs of the amplifier. It does not matter in what direction the tip is inserted into the amplifier.

## Freehand Probe Holder

The optional Freehand Probe Holder is designed to position the amplifier while maintaining a steady weight on the probe tip to prevent loss of contact with the circuit under test.

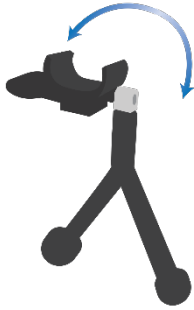

Turn the mounting head until the amplifier legs are in the desired position.



Place the amplifier body slightly behind the mounting bracket, then slide it forward until it sits securely within the bracket.

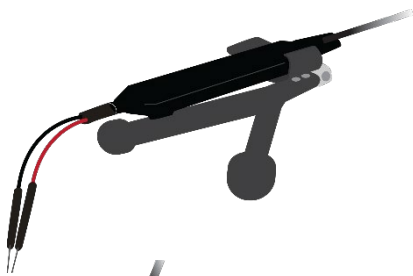

**For solder-in or Y-lead mounting:** bend the legs of the holder under the amplifier body, then turn the amplifier head toward the board just enough so that the weight of the leads is off the solder joints, but the tips maintain a good contact.



**For straight pin header or browser mounting:** stand the legs up then turn the amplifier body down so that the tip contacts the board.

### Connecting Tips

Two inputs are available on all probe tips. The red lead connects to the + signal, and the black lead to the – signal. For accurate measurements, both the + and – must be connected to the circuit under test.

To maintain the probe's high performance, exercise care when connecting tips to a circuit. Increasing the parasitic capacitance or inductance in the input paths may introduce a “ring” or slow the rise time of fast signals. Input leads that form a large loop area will pick up any radiated electromagnetic field that passes through the loop and may induce noise into the probe inputs. Because this signal will appear as a differential mode signal, the probe's common mode rejection will not remove it.

High common mode rejection requires precise matching of the relative gain or attenuation in the + and – input signal paths. Mismatches in additional parasitic capacitance, inductance, delay, and a source impedance difference between the + and – signals will lower the CMRR. Therefore, it is desirable to use the same length and type of wire for both inputs. When possible, try to connect the inputs to points in the circuit with approximately the same source impedance.

### Solder-in Tips

The 2” and high performance solder-in tips are intended to be soldered to runs or pads on the board under test.

It is best practice to trim the leads to the same length, but it is not required unless they are operating at the full bandwidth. To reduce peaking, trim the leads to half the original length (0.25” or 6.35 mm).

Using a small-tip soldering iron, attach the free wires beyond the resistors to the appropriate test points. The + input is red, the – input is black.

Normally, the performance of the solder-in tips is not affected by the position of the amplifier. It can be mounted straight upright or on an angle.

**Note:** The flexible cable connecting the solder-in tip to the amplifier is reasonably insensitive to placement, but it can be affected by large signal emitters on the device under test, so avoid placing it near these types of signals.

Mounting the amplifier in the Freehand when using the solder-in tips provides the most secure probing connection.



### **Hi-Temp Lead**

The Hi-Temp lead attaches to the board exactly as do the solder-in tips. The long lead provides isolation from the DUT when it is in an environmental chamber.

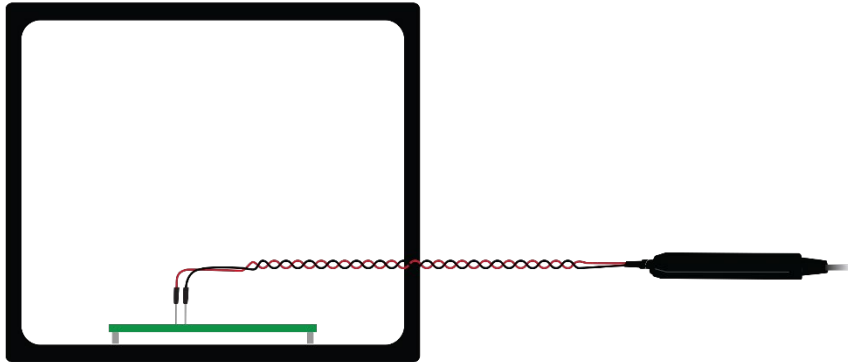

### **Y-lead Sockets**

The 2" and 5" Y-lead sockets provide flexibility for probing points far apart on the board, or deep within spaces where the amplifier cannot fit. They can be seated over pins or used with the single pins inserted into the leads for probing where there are no pins.

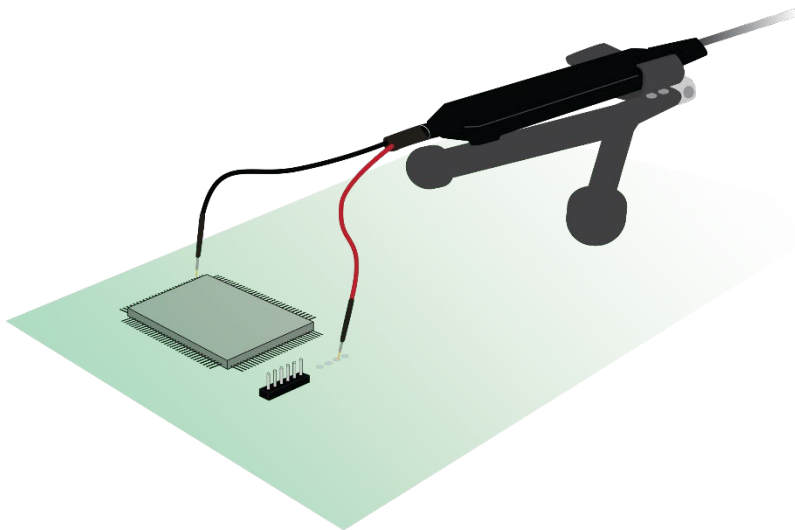

## 60 V Common Mode Differential Probes

---

### **Mini-Grabbers**

The mini-grabbers can be used to connect to very tightly spaced pins and legs.

1. Attach a Y-lead to the side of the T-bar.
2. Pull back on the wings to expose the hook.
3. Seat the hook over the probing point.
4. Release the wings to secure the grabber.

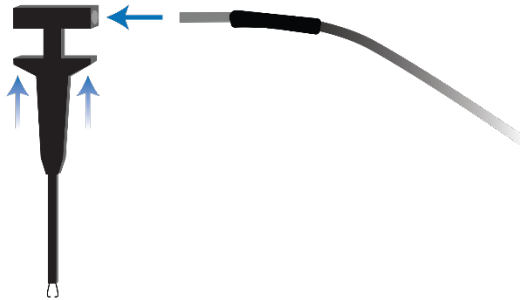

### **Micro-Grabbers**

The optional micro-grabbers are used to connect to IC legs and extremely small instrumentation.

1. Insert the pin at the top of the grabber into the end of a Y-lead.
2. Pull back on the tab to expose the hook.
3. Seat the hook over the probing point. You may need a microscope to view the connection.
4. Release the tab to secure the grabber.

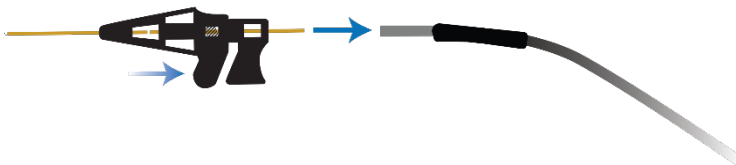

### Browser Tip

The browser tip has a very small form factor with very low mass and variable tip spacing. It is a good, all-around solution for probing in areas with a high concentration of test points or limited free space to fit a probe. The pogo pins at the far ends of the tip provide allowance for making contact with uneven surfaces.

The amplifier may be hand held or mounted when using the browser tip.



**CAUTION:** Maximum input voltage is 60 V when hand held.

Attach the tip to the amplifier before adjusting the tip spacing. Swivel the tips in either direction to move them closer together or apart.

**Note:** Fully closed spacing can only be achieved by turning both tips in one direction.



**CAUTION:** Avoid applying excessive lateral strain on the tip when pressing down. Do not use the tip to scrape the circuit.

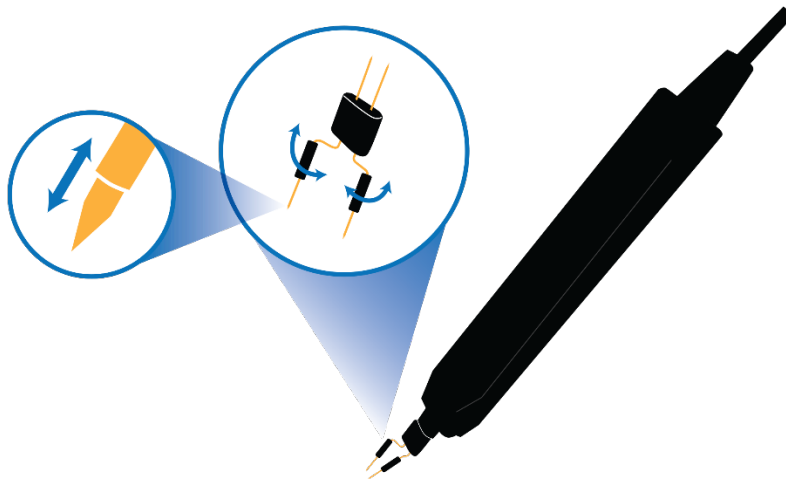

Unless the full probe bandwidth is required, a bandwidth limit can be applied on the oscilloscope to reduce peaking and achieve a more controlled response when using the browser.

## 60 V Common Mode Differential Probes

---

### Ground Lead

The bendable, socket-tipped ground lead can be used alone, or with the single pin or grabbers inserted for probing ground planes.

Insert the right-angled pin of the ground lead into the receptacle on the underside of the amplifier body, immediately below the differential input.

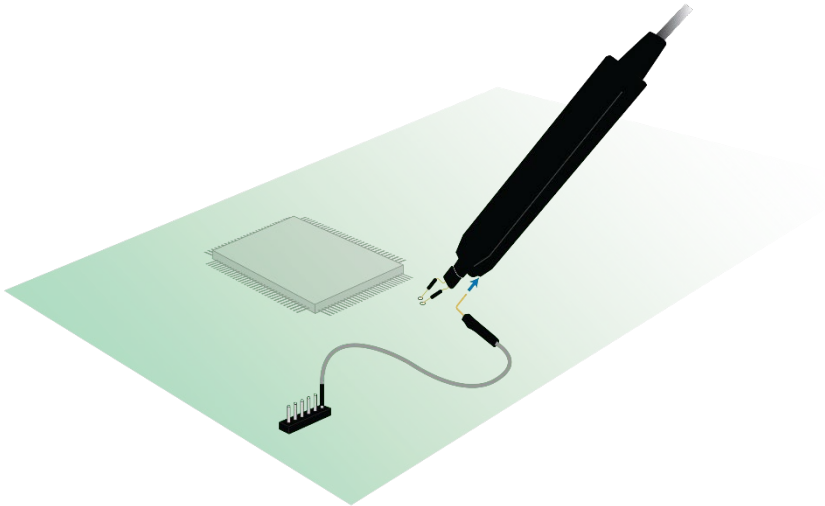

In most cases, when the common mode portion of the signal consists mainly of lower frequencies, the probe does not need to be connected to the DUT ground. This minimizes the effects of ground loop currents. Any signal corruption caused by not having the probe connected to ground of the signal under test is common to both inputs and is rejected by the differential operation of the probe.

However, capacitive coupling from AC mains may cause truly floating devices (like battery operated devices) to exceed the common mode range. In such cases, it is recommended to connect the probe ground to the DUT.

- In floating devices, connect the ground lead to the DUT's reference or common voltage.
- In high RF ambient noise environments, connect the ground lead to a good RF ground near the point where the signal is being measured.



**CAUTION:** Always use the ground lead when testing floating circuits, such as circuits powered from laboratory bench power supplies. These may damage the probe by exceeding the common mode input voltage.

## Using the PCF-200 Deskew Fixture

The PCF-200 deskew fixture may be used to determine the effect of probe input loading on the circuit under test, for verification of the probe's response to the signal being measured, or as a convenient way to deskew the signal path.

Use two BNC cables to connect a Fast Edge signal through the microstrip path you are using to the oscilloscope input channel.

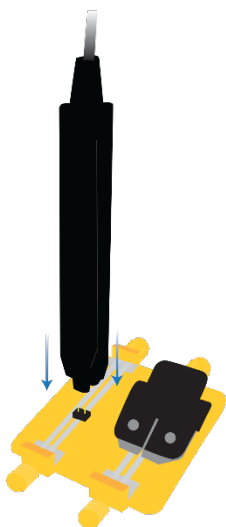
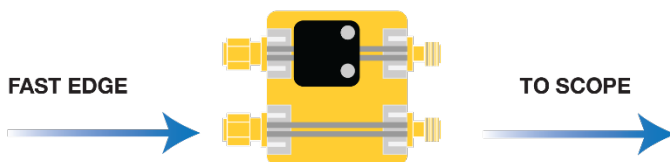

Generally, it is sufficient to deskew the signal path to the point of the amplifier differential input, for which you would connect the amplifier directly to the deskew fixture.

**To connect the amplifier or Y-leads to the fixture:** seat them over the square pins.

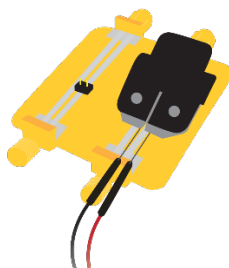

**To connect solder-in tips to the fixture:** press the black plastic tab to open the clamp, placing the resistor tips under the clamp so that the + tip contacts the center microstrip and the – tip contacts the ground plane. Release the clamp to grip the wires securely in place.

## 60 V Common Mode Differential Probes

### Operating from the Oscilloscope

When the probe is connected to a Teledyne LeCroy oscilloscope, the displayed scale factor and measurement values will be adjusted to account for the effective gain of the probe. The probe's internal attenuation is shown on the DLxx-CHM probe dialog, which is added to the oscilloscope's input channel dialogs when a probe is detected.

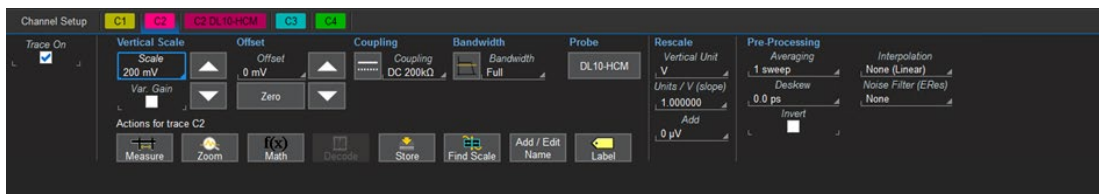

Section of channel setup dialog showing probe dialog tab behind it.

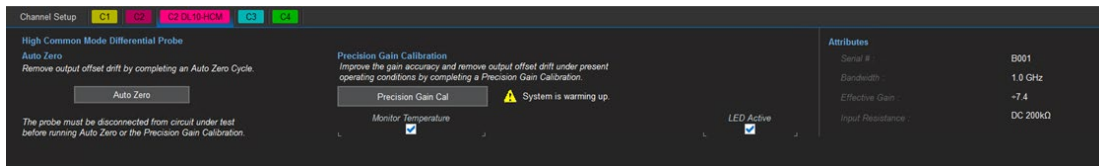

Section of DLxx-HCM dialog.

### Probe Volts/Div and Attenuation

The oscilloscope front panel Volts/Div knob and channel dialog ( $C_n$ ) Vertical Scale setting control the oscilloscope's scale and the probe's internal attenuation to give full available dynamic range. Some transition of the scale factor will result in a change of attenuation.

**Note:** The probe's input dynamic range is 80 Vpp ( $\pm 40$  V). When operated at the 20 V/div setting, traces over 40 V may be clipped. Apply channel offset to avoid clipping.

### Offset

Offset allows you to remove a DC bias voltage from the differential input signal while maintaining DC coupling. This ensures that the probe will never be overdriven while a signal is displayed on screen and prevents inaccurate measurements.

The probe's offset range is  $\pm 60$  V at all V/div settings.

### Bandwidth Limiting

To comply with various test standards used for quantifying output noise, the probe is capable of functioning at bandwidth limits from Full (maximum bandwidth) to 20 MHz depending on oscilloscope model. Make this setting on the input channel dialog.

## Auto Zero

Auto Zero corrects for DC offset drifts that naturally occur from thermal effects in the differential amplifier. For example, the DC offset drift of the 60 V common mode probes is  $250 \mu\text{V}/^\circ\text{C}$  (worst case) referred to the output. If the probe is set to 7.5x attenuation and the ambient temperature changes by  $10^\circ\text{C}$ , the DC offset drift could be as high as  $(250 \mu\text{V}/^\circ\text{C})(7.5)(10^\circ\text{C}) = 18.75 \text{ mV}$  referred to the probe tip. If the signal was 60 Vp-p in 70x attenuation mode, DC offset drift at the same ambient temperature could be as high as  $(250 \mu\text{V}/^\circ\text{C})(70)(10^\circ\text{C}) = 175 \text{ mV}$  at the probe tip (although any offset accuracy error from the oscilloscope itself would likely dominate the measurement).

To perform an Auto Zero:

1. Disconnect the probe from the circuit under test.
2. Warm up the system (oscilloscope and probe) until the “warming up” indicator on the probe dialog disappears:

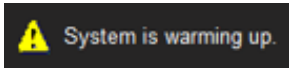

3. Touch the **Auto Zero** button on the DLxx-HCM dialog.

If the probe is disconnected then re-connected, repeat Auto Zero. Depending on the accuracy desired and/or changes in the ambient temperature, it may be necessary to Auto Zero more often.

## Precision Gain Calibration

Precision Gain Calibration can be used to improve the gain accuracy for the current measurement configuration. The calibration includes an Auto Zero procedure.

To perform a Precision Gain Calibration:

1. Disconnect the probe from the circuit under test.
2. Warm up the system (oscilloscope and probe) until the “warming up” indicator on the probe dialog disappears.
3. Touch the **Precision Gain Cal** button on the DLxx-HCM dialog.

## 60 V Common Mode Differential Probes

Each calibration is valid for the bandwidth, V/div and temperature ( $\pm 5\text{ }^{\circ}\text{C}$ ) at which it was performed. The probe dialog will indicate when the probe has a valid calibration and Precision Gain Calibration is in use:

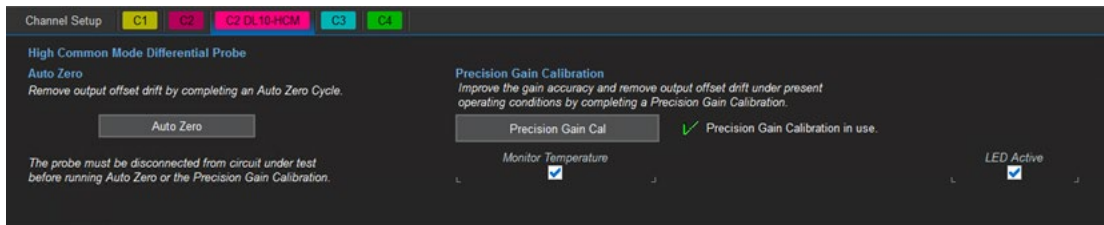

The probe dialog will also show that a calibration is needed when any of the calibrated conditions change by placing a red "X" next to the Precision Gain Cal button:

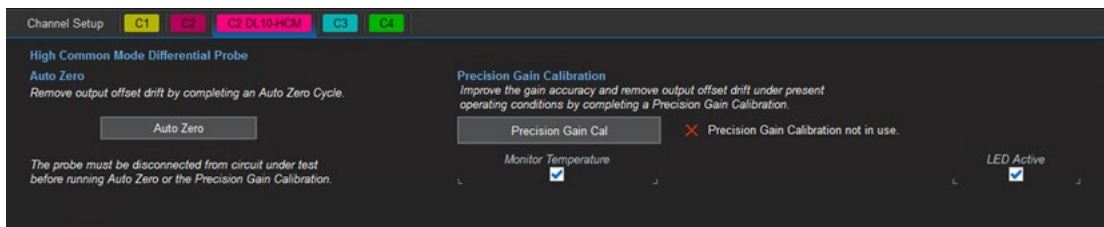

By default, the temperature is polled every 10 seconds if you have a valid calibration (green checkmark) to determine whether the probe is still in the  $\pm 5\text{ }^{\circ}\text{C}$  valid temperature range. Rarely, under certain signal conditions, this polling can create a minor disturbance. You can disable temperature polling deselecting **Monitor Temperature** on the probe dialog.

Calibrations are cached so that you do not need to repeat calibration for an exact set of conditions, only when a new V/div or bandwidth is introduced, or the temperature drifts outside the calibrated range. The probe can cache up to 100 unique calibrations.

### Probe Firmware Update

If an **Update Firmware** button appears on the probe dialog, the probe firmware requires an update for proper functioning. With the probe connected to the oscilloscope, touch the button to begin the update. The probe will appear to temporarily disconnect (there will be no DLxx-HCM dialog), and the oscilloscope message bar will say "Updating Firmware". The update takes approximately 30 seconds. When the update is complete, the probe will automatically reconnect and be usable.

**Note:** This procedure does not update the oscilloscope firmware.



# Maintenance

## Cleaning

Clean only the exterior surfaces of the device using a soft cloth or swab dampened with water or 75% isopropyl alcohol solution. Do not use harsh chemicals or abrasive cleansers. Dry the probe and accessories thoroughly before making any voltage measurements.



**CAUTION.** The probes are not waterproof. Under no circumstances submerge the probe in liquid or allow moisture to penetrate it.

## Calibration Interval

This probe has no adjustments. The recommended calibration interval is one year. A Performance Verification Procedure is included in this manual.

## Service Strategy

DL-HCM probes utilize fine-pitch surface mount devices. It is, therefore, impractical to attempt repair in the field. Defective probes must be returned to a Teledyne LeCroy service facility for diagnosis and exchange.



**CAUTION.** Do not remove the covers. Refer all servicing to qualified personnel. A defective probe under warranty will be replaced with a factory refurbished probe.

A probe that is not under warranty can be exchanged for a factory refurbished probe for a modest fee. Replacement probes are factory repaired, inspected, and calibrated to the same standards as a new product. You must return the defective probe in order to receive credit for the probe core.

## Replacement Parts

Replacement probe accessories can be ordered through your local service center. Visit [teledynelecroy.com/support/contact](http://teledynelecroy.com/support/contact) for a complete list of centers.

### Returning a Product for Service

Contact your regional Teledyne LeCroy service center for calibration or other service. If the product cannot be serviced on location, the service center will give you a **Return Material Authorization (RMA) code** and instruct you where to ship the product. All products returned to the factory must have an RMA.

**Return shipments must be prepaid.** Teledyne LeCroy cannot accept COD or Collect shipments. We recommend air-freighting. Insure the item you're returning for at least the replacement cost.

1. Remove all accessories from the probe.
2. Pack the probe in its case. If possible, include all tips. Do not include the manual.
3. Pack the case in its original shipping box, or an equivalent carton with adequate padding to avoid damage in transit.
4. Mark the outside of the box with the shipping address given to you by Teledyne LeCroy; be sure to add the following:
  - ATTN: <RMA code assigned by Teledyne LeCroy>
  - FRAGILE
5. If returning a product to a different country: contact Teledyne LeCroy Service for instructions on completing your import/export documents.

Extended warranty, calibration and upgrade plans are available for purchase. Contact your Teledyne LeCroy sales representative to purchase a service plan.

For a complete list of Teledyne LeCroy offices by country, including our sales and distribution partners, visit: [teledynelecroy.com/support/contact](http://teledynelecroy.com/support/contact).

---

## Performance Verification Procedure

This procedure can be used to verify the warranted characteristics of a DLxx-HCM probe. It tests: Output Zero Voltage, DC/LF Attenuation Accuracy and Probe Bandwidth.

The recommended calibration interval for the DLxx-HCM models is one year. Complete the performance verification as the first step of annual calibration. Results can be recorded on a photocopy of the Test Record provided.

Performance verification can be completed without removing the probe covers or exposing the user to hazardous voltages. There are no adjustments.

### Required Equipment

The following table lists the test equipment and accessories (or their equivalents) that are required for performance verification of the probe. This procedure is designed to minimize the number of calibrated test instruments required. Only the parameters listed in boldface in the "Minimum requirements" column must be calibrated to the accuracy indicated.

**Note:** In this procedure, the RF signal generator is used only for making relative measurements. It is not required to calibrate the generator, because the output of the generator is measured with an oscilloscope.

The warranted characteristics of the 60 V common mode probes are valid within the operating environment of 17 °C to 27 °C. However, some of the other test equipment used may have environmental limitations required to meet the accuracy needed for the procedure. Be sure that the ambient conditions meet the requirements of all the test equipment used in this procedure.

As the input and output connector types may vary on different brands and models of test instruments, additional adapters or cables may be required.

**Note:** The correct operation of a DLxx-HCM probe requires firmware version 9.3.x.x or higher. The version can be verified by selecting Utilities > Utilities Setup > Status from the oscilloscope menu bar. Contact your local Teledyne LeCroy representative or visit the software download page of our website if your oscilloscope firmware requires updating.

## 60 V Common Mode Differential Probes

### Table of Required Test Equipment

Description	Requirements	Example Equipment
Digital Oscilloscope	ProBus Interface Windows 10 ≥ 2 GHz for Bandwidth Test	Teledyne LeCroy: <ul style="list-style-type: none"> <li>WaveRunner 8208HD</li> <li>WavePro 254HD</li> <li>HDO6000B (for DL02/DL05)</li> </ul>
Digital Multimeter (DMM)	<b>4.5 digit</b> <b>DC: 0.1% Accuracy</b> <b>AC: 0.1% Accuracy</b> Dual inputs	Keysight 34401A
Function Generator	Sine wave output, amplitude adjustable to 14.14 Vp-p (5 Vrms) into 1 MΩ at 70 Hz	Keysight 33120A
RF Signal Generator	Sine wave output 1 GHz +6 dBm output	Anritsu MG3690C
BNC Coaxial Cable (2)	Male to Male, 50 Ω, 36" Cable	Pomona 2249-C-36 Pomona 5697-36
SMA-BNC Adapter		
BNC Tee Connector	Male to Dual Female	Pomona 3285
Calibration Fixture	0.1 mm square pin head	Teledyne LeCroy PCF200
ProBus Extender Cable		Teledyne LeCroy PROBUS-CF01
Terminator, Precision BNC	50 Ω ± 0.05%	Teledyne LeCroy TERM-CF01
Banana Plug Adapter (2)	Female BNC to Dual Banana Plug	Pomona 1269
BNC to Mini Hook Cable	BNC Male to Mini Hook, 36"	Pomona 5187-C-36

## Preliminary Set Up

1. Connect the probe (without tips) to oscilloscope channel 1.
2. Turn on the oscilloscope and allow at least 20 minutes warm-up time before performing the Verification Procedure.
3. Turn on the other test equipment and allow them to warm up for the manufacturer's recommended time.
4. While the instruments are reaching operating temperature, make a photocopy of the DLxx-HCM Probe Test Record and fill in the necessary data.

## Functional Check

The functional check will verify the basic operation of the probe functions. Perform the Functional Check prior to the Verification Procedure.

1. Return to the factory default settings:
  - a. Select **File > Recall Setup** from the menu bar.
  - b. Touch the **Recall Default** button.
2. Touch the **C1 descriptor** box to open the C1 dialog.
3. Verify that the correct probe is sensed and displayed on the probe dialog tab behind the C1 dialog.
4. If the update firmware button is present, update the firmware.

## Verification Procedure

### A. Output Zero Voltage

1. Leave the probe connected to oscilloscope C1. Set:
  - a. **C1 Vertical Scale** to **200 mV/div**
  - b. **Horizontal Scale** (timebase) to **1.0  $\mu$ s/div**
2. Turn on measurement **P1** and set it to measure the **mean of C1**. Turn on **statistics**.
3. On the C1DLxx-HCM dialog (behind the C1 dialog), touch **AutoZero**.
4. Wait an additional 15 minutes, then **clear sweeps** on C1.
5. Record the value of P1: mean (C1) as "Output Zero" on the test record.
6. Verify that the value of Output Zero is less than the value on the test record.

## 60 V Common Mode Differential Probes

---

### **B. DC/LF Attenuation Accuracy**

1. Connect the BNC tee to the output of the function generator.
2. Connect the BNC to Mini Hook cable to the BNC tee on the output of the function generator.
3. Insert the Straight Pin Header into the probe head and connect the mini hooks to the pins. Attach the red mini hook to the probe's positive (+) input and the black mini hook to the probe's negative (-) input.
4. Attach a BNC cable to the unused female port of the BNC tee, connect a dual banana plug adapter to the other end of the cable, and plug the dual banana plug adapter into the rear DMM input. Be sure the banana plug's BNC shield side (marked "GROUND") is connected to the LOW or COMMON input of the DMM, and the BNC's center conductor is connected to the HI or INPUT V input of the DMM.
5. Set the DMM to read AC voltage and the range to measure 5.0 Vrms.
6. Set the mode of the function generator to sine wave and the frequency to 70 Hz.
7. Remove the probe from oscilloscope C1 and connect the oscilloscope side of the ProBus extender cable directly to C1. Connect the other end of the ProBus extender to the probe and the BNC output of the extender to the precision 50  $\Omega$  terminator.
8. Connect the banana plugs of the precision 50  $\Omega$  terminator to the front DMM input.

### **VERIFY TOP RANGE DC GAIN ACCURACY**

9. Toggle the DMM to the rear input. Set the output amplitude of the function generator to 5 Vrms  $\pm$ 10 mV as measured on the DMM.
10. Record the output voltage to 1 mV resolution as "Generator Output Voltage, Top Range". Be careful not to alter the output amplitude after the reading is recorded.
11. Set the C1 Vertical Scale to 5 V/div. Open the C1 DLxx-HCM dialog and record the gain value shown as "Effective Gain, Top Range".
12. Take the recorded generator output voltage and divide by the effective gain. Record this value as "Expected Output Voltage, Top Range".
13. Toggle the DMM to the front input. Measure the output voltage and record this as "Measured Output Voltage, Top Range".
14. Calculate the gain error by taking  $100 * [(Measured Output Voltage) - (Expected Output Voltage)] / (Expected Output Voltage)$ . Record this value as the % Gain Error. Verify that this is within the limits given on the data sheet.

**VERIFY MID RANGE DC GAIN ACCURACY**

15. Toggle the DMM to the rear input and set the output amplitude of the signal generator to 3 V<sub>rms</sub> ±10 mV as measured on the DMM.
16. Record the output voltage to 1 mV resolution as "Generator Output Voltage, Mid Range". Be careful not to alter the output amplitude after the reading is recorded.
17. Set the C1 Vertical Scale to 2 V/div. Open the C1DLxx-HCM dialog and record the gain value shown as "Effective Gain, Mid Range".
18. Take the recorded generator output voltage and divide by the effective gain. Record this value as "Expected Output Voltage, Mid Range".
19. Toggle the DMM to the front input. Measure the output voltage and record this as "Measured Output Voltage, Mid Range".
20. Calculate the gain error by taking  $100 * [(Measured\ Output\ Voltage) - (Expected\ Output\ Voltage)] / (Expected\ Output\ Voltage)$ . Record this value as the "% Gain Error, Middle Range". Verify that this is within the limits given on the data sheet.

**VERIFY LOW RANGE DC GAIN ACCURACY**

21. Toggle the DMM to the rear input and set the output amplitude of the signal generator to 2 V<sub>rms</sub> ±10 mV as measured on the DMM.
22. Record the output voltage to 1 mV resolution as "Generator Output Voltage, Low Range" in the Test Record. Be careful not to alter the output amplitude after the reading is recorded.
23. Set the C1 Vertical Scale to 1 V/div. Open the C1DLxx-HCM dialog and record the gain value shown as "Effective Gain, Low Range".
24. Take the recorded generator output voltage and divide by the effective gain. Record this value as "Expected Output Voltage, Low Range".
25. Toggle the DMM to the front input. Measure the output voltage and record this as "Measured Output Voltage, Low Range".
26. Calculate the gain error by taking  $100 * [(Measured\ Output\ Voltage) - (Expected\ Output\ Voltage)] / (Expected\ Output\ Voltage)$ . Record this value as the "% Gain Error, Low Range". Verify that this is within the limits given on the data sheet.

## 60 V Common Mode Differential Probes

---

### C. Probe Bandwidth

1. Disconnect the probe from the mini hooks and the ProBus extender and connect it to oscilloscope channel 1.
2. Set the RF signal generator to 1 GHz for DL10-HCM, 500 MHz for DL05-HCM or 250 MHz for DL02-HCM at +6 dBm output.
3. Using the square-pin microstrip path, connect the PCF200 to the oscilloscope C2 input using an SMA-BNC adapter. Connect the signal generator to the C2 input through the PCF200.
4. Attach the probe to the PCF200 by seating the amplifier over the square pins.
5. Set up the oscilloscope as follows (image next page):
  - a. C1 and C2 Vertical Scale 200 mV/div
  - b. C2 Coupling DC50Ω and Bandwidth Full
  - c. Horizontal Scale (timebase) 10 ns/div
  - d. Trigger on C2 Edge, Level = 0 V
  - e. Measurements:
    - i. P1 sdev of C1
    - ii. P2 sdev of C2
    - iii. P3 ratio of P1/P2
    - iv. P4 freq of C2

The probe bandwidth is defined as the frequency at which the probe amplitude is 3 dB down from the input signal amplitude. This would be the frequency at which the ratio measurement P3 drops to 0.7071.

6. Record the signal loss ratio (P3) with RF signal input and verify it is greater than 0.7071.





This completes the Performance Verification of the DLxx-HCM probe. Complete and file the test record as required to support your internal calibration procedures.

## 60 V Common Mode Differential Probes

---

### DL\_\_\_\_\_ -HCM Test Record

Serial Number: \_\_\_\_\_

Asset / Tracking Number: \_\_\_\_\_

Date: \_\_\_\_\_

Technician: \_\_\_\_\_

Equipment	Model	Serial Number	Calibration Due Date
Oscilloscope			
Digital Multimeter			
Function Generator			
RF Generator			

Step	Description	Intermediate Data	Test Result
A6	Output Zero Voltage (Test limit 0 V $\pm$ 5 mV)		V
B10	Generator Output Voltage, Top Range	V	
B11	Effective Gain, Top Range	V	
B12	Expected Output Voltage, Top Range	V	
B13	Measured Output Voltage, Top Range	V	
B14	% Gain Error, Top Range		%
B16	Generator Output Voltage, Mid Range	V	
B17	Effective Gain, Mid Range	V	
B18	Expected Output Voltage, Mid Range	V	
B19	Measured Output Voltage, Mid Range	V	
B20	% Gain Error, Mid Range		%
B22	Generator Output Voltage, Low Range	V	
B23	Effective Gain, Low Range	V	
B24	Expected Output Voltage, Low Range	V	
B25	Measured Output Voltage, Low Range	V	
B26	% Gain Error, Low Range		%
C6	Signal Loss at Max. Bandwidth		V/V

Permission is granted to photocopy this page to record the results of the Performance Verification procedure. File the completed record as required by applicable internal quality procedures. Line numbers correspond to steps in the procedure that require the recording of data. Record the actual specification limit check under "Test Result". Record other measurements and intermediate calculations that support the limit check under "Intermediate Data".

---

# Reference

## Certifications

For the full list of current certifications, see the EC Declaration of Conformity shipped with your product. The probe complies with:

AS/NZS CISPR 11:2011 Radiated and Conducted Emissions, Group 1, Class A.

IEC/EN 61010-031:2015 Safety requirements for electrical equipment for measurement, control, and laboratory use – Part 031: Safety requirements for hand-held probe assemblies for electrical measurement and test.

EN 61326-1:2013, EMC requirements for electrical equipment for measurement, control, and laboratory use.<sup>1, 2, 3</sup>

1. This product is intended for use in nonresidential areas only. Use in residential areas may cause EM interference.
2. Emissions exceeding the levels required by this standard may occur when product is connected to a test object.
3. To ensure compliance with the applicable EMC standards, use high quality shielded interface cables.



The probe is marked with this symbol to indicate that it complies with the applicable European Union requirements to Directives 2012/19/EU on Waste Electrical and Electronic Equipment (WEEE).

For more information about proper disposal and recycling of your Teledyne LeCroy product, visit [teledynelecroy.com/recycle](http://teledynelecroy.com/recycle).

Unless otherwise specified, all materials and processes are compliant with RoHS Directive 2011/65/EU in its entirety, inclusive of any further amendments or modifications of said Directive.

### Technical Support

For a complete list of offices by country, including our sales & distribution partners, visit:

[teledynelecroy.com/support/contact](http://teledynelecroy.com/support/contact)

Teledyne LeCroy  
700 Chestnut Ridge Road  
Chestnut Ridge, NY, 10977, USA  
[teledynelecroy.com](http://teledynelecroy.com)

#### US Sales and Service:

Ph: 800-553-2769 / 845-425-2000

FAX: 845-578-5985

#### US Support:

Ph: 800-553-2769

[support@teledynelecroy.com](mailto:support@teledynelecroy.com)

### Warranty

THE WARRANTY BELOW REPLACES ALL OTHER WARRANTIES, EXPRESSED OR IMPLIED, INCLUDING BUT NOT LIMITED TO ANY IMPLIED WARRANTY OF MERCHANTABILITY, FITNESS, OR ADEQUACY FOR ANY PARTICULAR PURPOSE OR USE. TELEDYNE LECROY SHALL NOT BE LIABLE FOR ANY SPECIAL, INCIDENTAL, OR CONSEQUENTIAL DAMAGES, WHETHER IN CONTRACT OR OTHERWISE. THE CUSTOMER IS RESPONSIBLE FOR THE TRANSPORTATION AND INSURANCE CHARGES FOR THE RETURN OF PRODUCTS TO THE SERVICE FACILITY. TELEDYNE LECROY WILL RETURN ALL PRODUCTS UNDER WARRANTY WITH TRANSPORT PREPAID.

The product is warranted for normal use and operation, within specifications, for a period of one year from shipment. Teledyne LeCroy will either repair or, at our option, replace any product returned to one of our authorized service centers within this period. However, in order to do this we must first examine the product and find that it is defective due to workmanship or materials and not due to misuse, neglect, accident, or abnormal conditions or operation.

Teledyne LeCroy shall not be responsible for any defect, damage, or failure caused by any of the following: a) attempted repairs or installations by personnel other than Teledyne LeCroy representatives, b) improper connection to incompatible equipment, or c) use of non-Teledyne LeCroy supplies. Furthermore, Teledyne LeCroy shall not be obligated to service a product that has been modified or integrated where the modification or integration increases the task duration or difficulty of servicing the product. Spare and replacement parts and repairs all have a 90-day warranty.

Products not made by Teledyne LeCroy are covered solely by the warranty of the original equipment manufacturer.



dlxx-hcm-user-manual-eng\_05apr23.pdf  
March, 2023



700 Chestnut Ridge Road  
Chestnut Ridge, NY 10977  
USA

[teledynelecroy.com](http://teledynelecroy.com)