

Lever-Type Dial Indicators DIAL TEST INDICATORS

SMALL TOOL INSTRUMENTS
AND DATA MANAGEMENT



Lever Type Dial Indicator Dial Test Indicator

Inspection

- A "Certificate of Inspection" is provided with Dial Test Indicators.

Easy-to-read dial

- Glare-free flat crystal face allows easy reading of graduations.
- Multi-layer and composite coatings allow a stain repellent, anti-reflective crystal.



Conventional New

Improved visibility

- Using universal fonts, changing dial face color and reviewing the relationship between pointer and scale marks have drastically improved visibility.



Conventional New

Attachable limit hands

- Limit hands (optional) can be attached to the bezel the same as for dial indicators, allowing easy identification of the upper and lower limits of tolerance.

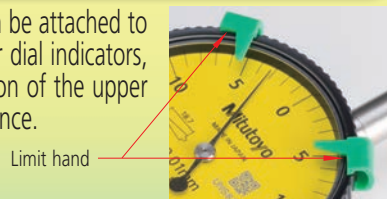

Limit hand

Contact point length is marked on the dial face

- As the length of the contact point fitted affects the indicator's scale factor the length that gives a scale factor of unity is marked on the dial face to assist a customer when ordering the correct replacement contact point.

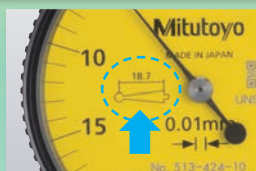

No bezel detachment

- A flange prevents the bezel from unintentional removal due to applying a force to the bezel during handling.

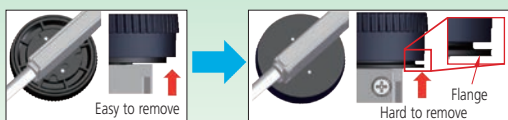

Conventional

New

Naming of parts

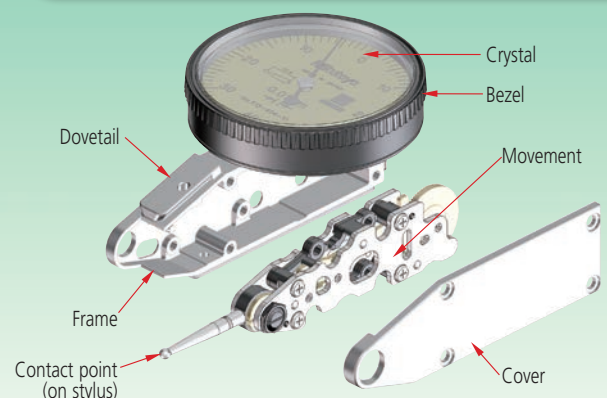

Crystal
Bezel

Movement

Dovetail

Frame

Contact point
(on stylus)

Cover

certificate attached

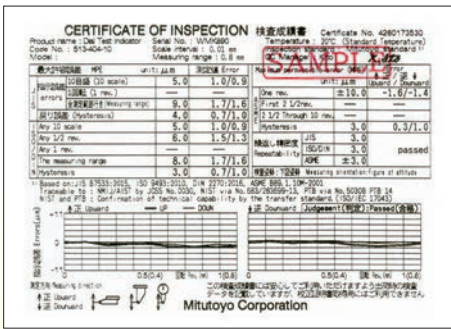

Improved contact point bearing gives smoother tracking

- The conventional method of mounting the contact point pivot bearing screw in the frame is prone to allowing looseness to develop with prolonged use. A unique sub-plate structure to house this screw has now been incorporated in all models and eliminates this issue.

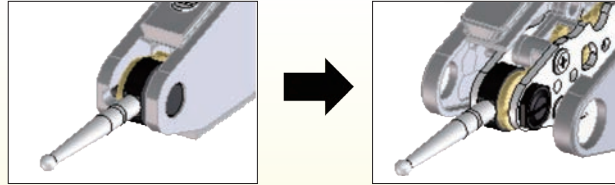

Contact point bearing screw held in frame. Contact point bearing screw held in sub-plate.

Extended contact point length for 0.001 mm, 0.002 mm, and 0.0001 in graduation models

- Longer contact points have been introduced on the most sensitive indicators to make probing those features of a workpiece that are difficult to access more user-friendly.

0.002 mm graduation models: L1 now 18.7 mm, was 14.7 mm
 L2 now 15.2 mm, was 11.2 mm

0.001 mm graduation models: L1 now 14.7 mm, was 12.8 mm
 L2 now 11.2 mm, was 9.3 mm

0.0001 in graduation models: L1 now 0.75 in, was 0.59 in
 L2 now 0.61 in, was 0.45 in

Ruby ball-tipped contact point added to lineup

- A ruby tip has resistance to wear several times greater than a carbide tip and, since it is nonconductive, it can be used with safety even on an electrical discharge machine.

A choice of dial position

Our product lineup offers four models, each with a different orientation of the dial on the frame to allow best visibility of the dial face in any specific situation.

- Horizontal type: the standard model - the dial is on top of the frame.
- Vertical type: the model with the dial on the end of the frame.
- Horizontal (20° tilted face) type: the model with the dial on top of the frame but tilted backward at 20°.
- Parallel type: the model with the dial on the side of the frame.

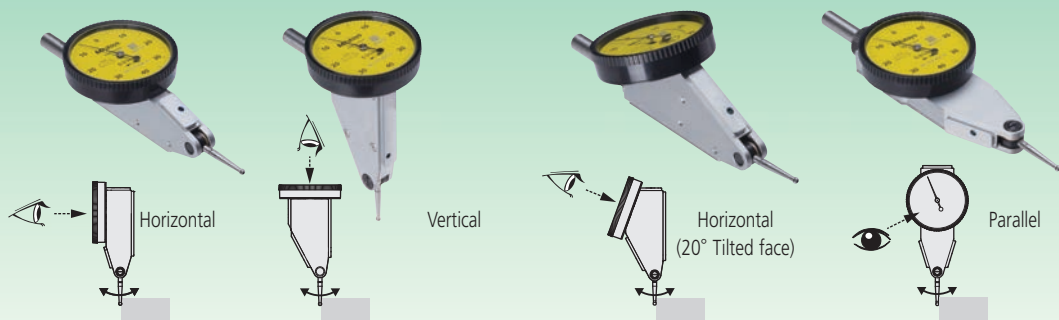

Lever Type Dial Indicator Pocket Type Dial Test Indicator

Improved visibility

- Using universal fonts, changing dial face color and reviewing the relationship between pointer and scale marks have drastically improved visibility.



Conventional

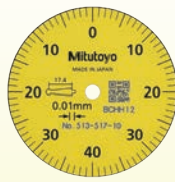

New

Attachable limit hands

- Limit hands (optional) can be attached to the bezel the same as for dial indicators, allowing easy identification of the upper and lower limits of tolerance.

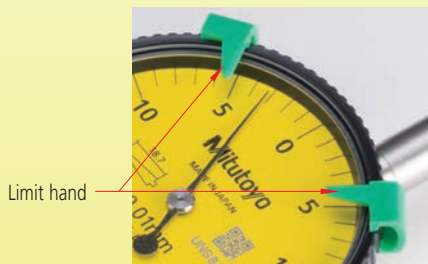

Contact point length is marked on the dial face

- As the length of the contact point fitted affects the indicator's scale factor the length that gives a scale factor of unity is marked on the dial face to assist a customer when ordering the correct replacement contact point.

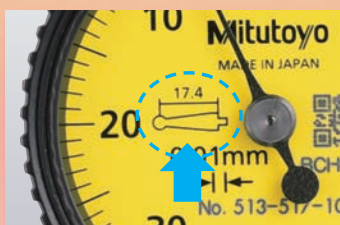

Integrated bezel and crystal structure

- Bonding the bezel and crystal together leaves no gap for cutting fluid or oil to penetrate through to the dial face.

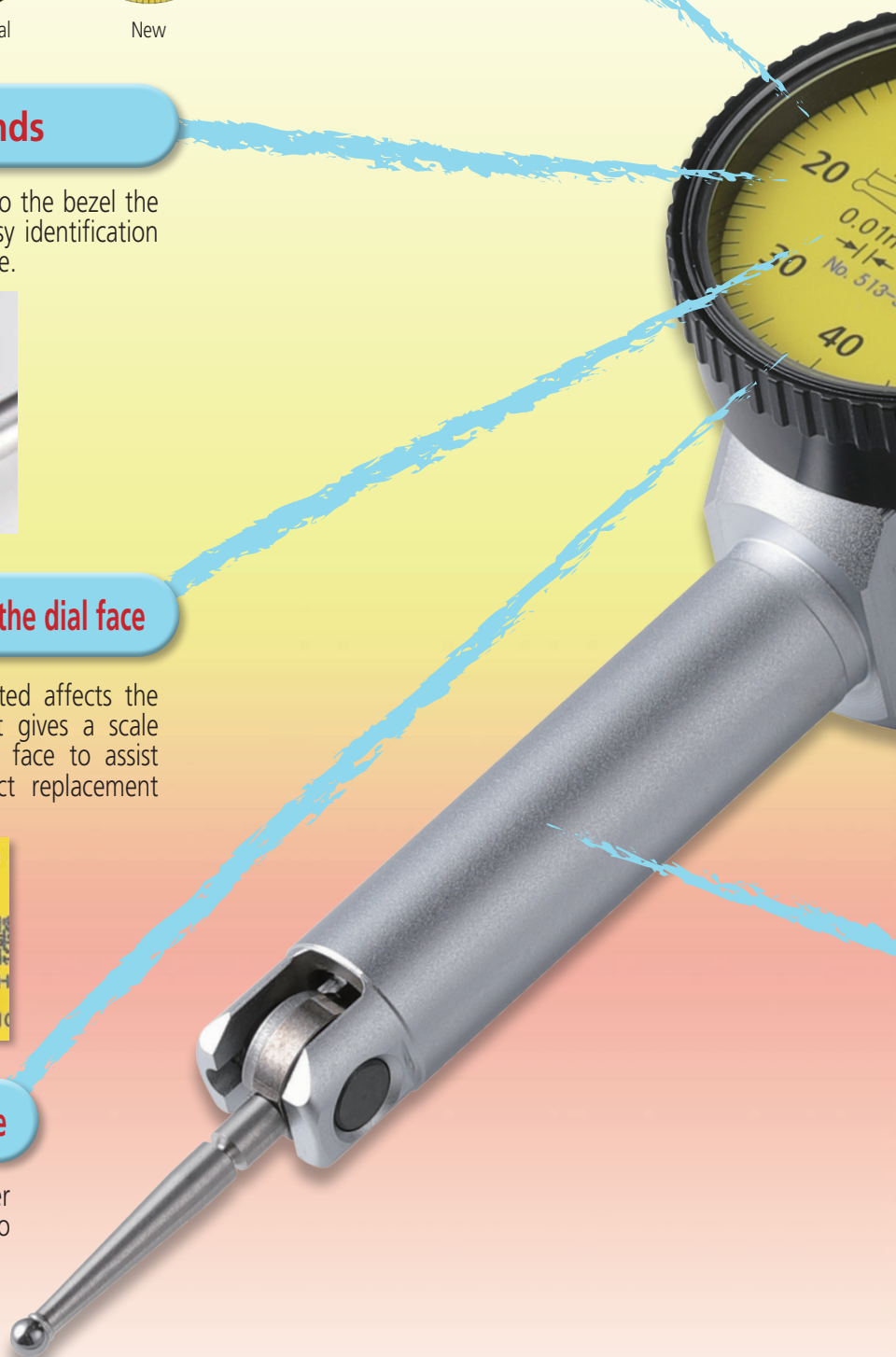

Inspection certificate attached

- A "Certificate of Inspection" is provided with Pocket Type Dial Test Indicators.



Easy-to-read dial

- Glare-free flat crystal face allows easy reading of graduations.
- Multi-layer and composite coatings allow a stain repellent, anti-reflective crystal.



Conventional

New

Clutch type (with a clutch lever)

- There are two types of Mitutoyo Dial Test Indicator: The non-clutch type (without a clutch lever) and the clutch type (with a clutch lever)

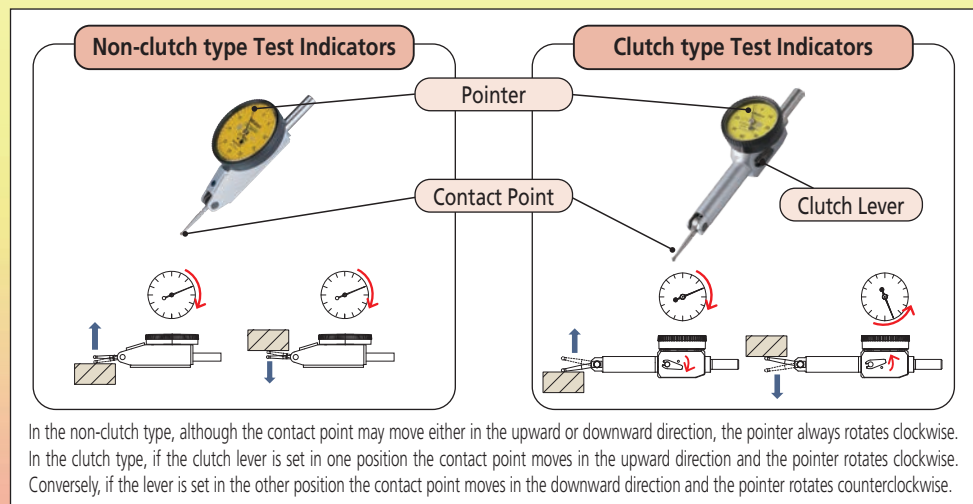

Improved insertion depth

- Slim body can reach a shallow and deep space to be measured.

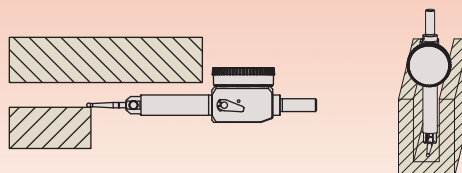



Horizontal (Standard model)

Metric Provides wide variations of models conforms to the required accuracy, range, and surface of workpieces.



Contact point No. 137557



Graduation: 0.01 mm
Range: 0.5 mm

- Standard
- Double scale spacing
- Carbide contact point



Contact point No. 131324



Graduation: 0.01 mm
Range: 0.5 mm

- Long contact point
- Double scale spacing
- Carbide contact point



Contact point No. 21CZA210



Graduation: 0.01 mm
Range: 0.5 mm

- Standard
- Double scale spacing
- Ruby contact point



Contact point No. 21CZA201



Graduation: 0.01 mm
Range: 0.8 mm

- Standard
- Ruby contact point



Contact point No. 137557



Graduation: 0.01 mm
Range: 0.5 mm

- Double scale spacing
- Compact
- Carbide contact point



Contact point No. 103006



Graduation: 0.01 mm
Range: 0.8 mm

- Compact
- Carbide contact point



Contact point No. 103006



Graduation: 0.01 mm
Range: 0.8 mm

- Standard
- Carbide contact point



Contact point No. 136013



Graduation: 0.01 mm
Range: 1.0 mm

- Long contact point
- Carbide contact point



513-477-10E

Contact point No. 21CZA211

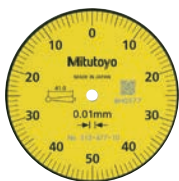

Graduation: 0.01 mm
Range: 1.0 mm

- Long contact point
- Ruby contact point



513-475-10E

Contact point No. 21CZB068



Graduation: 0.002 mm
Range: 0.2 mm

- Standard
- Ruby contact point



513-426-10E/513-426-10A

Contact point No. 137557

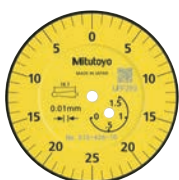

Graduation: 0.01 mm
Range: 1.5 mm

- With revolution counter
- Double scale spacing
- Carbide contact point



513-425-10E/513-425-10A

Contact point No. 103011



Graduation: 0.002 mm
Range: 0.6 mm

- With revolution counter
- Carbide contact point



513-405-10E/513-405-10A/
513-405-10T

Contact point No. 103011



Graduation: 0.002 mm
Range: 0.2 mm

- Standard
- Carbide contact point



513-465-10E

Contact point No. 103011

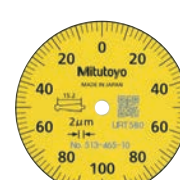

Graduation: 0.002 mm
Range: 0.2 mm

- Compact
- Carbide contact point



513-471-10E

Contact point No. 21CZA209

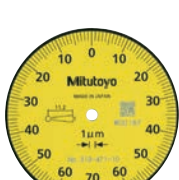

Graduation: 0.001 mm
Range: 0.14 mm

- High accuracy
- Ruby contact point



513-401-10E

Contact point No. 103010



Graduation: 0.001 mm
Range: 0.14 mm

- High accuracy
- Carbide contact point



Horizontal (Standard model)

Inch



513-402-10E/513-402-10T

Contact point No. 133195



Graduation: 0.0005 in
Range: 0.03 in

- Standard
- Carbide contact point



513-462-10E

Contact point No. 133195

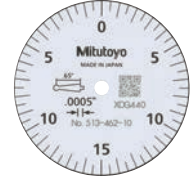

Graduation: 0.0005 in
Range: 0.03 in

- Compact
- Carbide contact point



513-472-10E

Contact point No. 21CZA204



Graduation: 0.0005 in
Range: 0.03 in

- Standard
- Ruby contact point



513-403-10E/513-403-10T

Contact point No. 21CZB064



Graduation: 0.0001 in
Range: 0.008 in

- Standard
- Carbide contact point



513-412-10E/513-412-10T

Contact point No. 136290



Graduation: 0.0005 in
Range: 0.03 in

- Long contact point
- Carbide contact point



513-473-10E

Contact point No. 21CZB112



Graduation: 0.0001 in
Range: 0.008 in

- Standard
- Ruby contact point



513-479-10E

Contact point No. 21CZA214

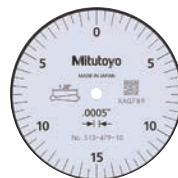

Graduation: 0.0005 in
Range: 0.03 in

- Long contact point
- Ruby contact point



513-463-10E

Contact point No. 21CZB064

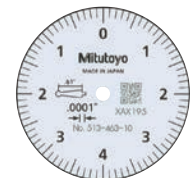

Graduation: 0.0001 in
Range: 0.008 in

- Compact
- Carbide contact point

Metric / inch



513-409-10E/513-409-10T

Contact point No. 103011



Graduation: 0.002 mm/0.0001 in
Range: 0.2 mm/0.0076 in

Carbide contact point

Inch / Metric



513-406-10E/513-406-10T

Contact point No. 133195



Graduation: 0.0005 in/0.01 mm
Range: 0.03 in/0.7 mm

Carbide contact point

DIMENSIONS

Horizontal

Unit: mm

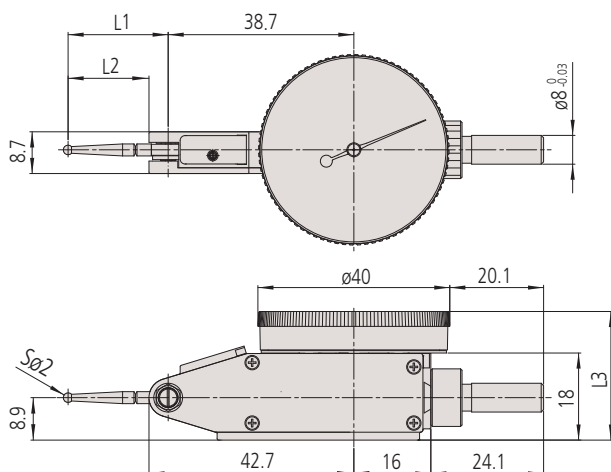

Type	Order No.	L1	L2	L3	
Horizontal	513-401-10E	14.7	11.2	27	
	513-471-10E				
	513-405-10E/A/T				
	513-475-10E	18.7	15.2		28
	513-425-10E/A				
	513-404-10E/A/T				
	513-474-10E	20.9	17.4	27	
	513-424-10E/A/T				
	513-426-10E/A				
	513-478-10E	22.2	18.7	28	
	513-414-10E/A/T				
	513-415-10E/A/T				
513-477-10E	37.4	33.9	27		
	44.5	41.0			

Compact

Unit: mm

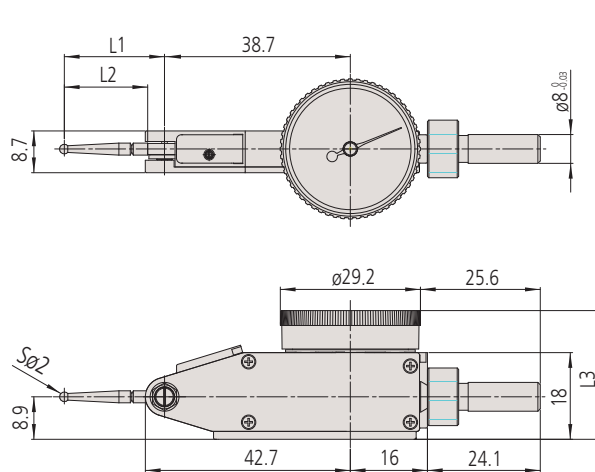

Type	Order No.	L1	L2	L3
Compact	513-465-10E	18.7	15.2	27
	513-464-10E	20.9	17.4	
	513-466-10E	22.2	18.7	

Note: A slight difference may occur depending on the center of the contact point, graduation plate, and stem fixing position, etc.



SPECIFICATIONS

Order No.			Graduation (mm)	Range (mm)	Dial reading	Maximum permissible error (MPE)* (μm)				Mass (g)	Measuring force (N)	High accuracy	With revolution counter	Long contact point	Standard	Double scale spacing	Compact	Carbide contact point	Ruby contact point
Basic set	Plus set	Full set				Measuring range	One rev.	10 scale divisions	Hysteresis										
513-424-10E	513-424-10A	513-424-10T	0.01	0.5	0-25-0	6	-	5	3	45	0.3 or less	<input checked="" type="checkbox"/>	<input checked="" type="checkbox"/>	<input checked="" type="checkbox"/>	<input checked="" type="checkbox"/>	<input checked="" type="checkbox"/>	<input checked="" type="checkbox"/>	<input checked="" type="checkbox"/>	<input checked="" type="checkbox"/>
513-478-10E	-	-																	
513-466-10E	-	-		0.8	0-40-0	9	-	5	3	41	0.3 or less	<input checked="" type="checkbox"/>	<input checked="" type="checkbox"/>	<input checked="" type="checkbox"/>	<input checked="" type="checkbox"/>	<input checked="" type="checkbox"/>	<input checked="" type="checkbox"/>	<input checked="" type="checkbox"/>	<input checked="" type="checkbox"/>
513-404-10E	513-404-10A	513-404-10T																	
513-414-10E	513-414-10A	513-414-10T		0.5	0-25-0	10	-	5	3	45	0.2 or less	<input checked="" type="checkbox"/>	<input checked="" type="checkbox"/>	<input checked="" type="checkbox"/>	<input checked="" type="checkbox"/>	<input checked="" type="checkbox"/>	<input checked="" type="checkbox"/>	<input checked="" type="checkbox"/>	<input checked="" type="checkbox"/>
513-474-10E	-	-																	
513-464-10E	-	-		0.8	0-40-0	9	-	5	3	41	0.3 or less	<input checked="" type="checkbox"/>	<input checked="" type="checkbox"/>	<input checked="" type="checkbox"/>	<input checked="" type="checkbox"/>	<input checked="" type="checkbox"/>	<input checked="" type="checkbox"/>	<input checked="" type="checkbox"/>	<input checked="" type="checkbox"/>
513-415-10E	513-415-10A	513-415-10T																	
513-477-10E	-	-		1.0	0-50-0	10	-	5	3	45	0.2 or less	<input checked="" type="checkbox"/>	<input checked="" type="checkbox"/>	<input checked="" type="checkbox"/>	<input checked="" type="checkbox"/>	<input checked="" type="checkbox"/>	<input checked="" type="checkbox"/>	<input checked="" type="checkbox"/>	<input checked="" type="checkbox"/>
513-426-10E	513-426-10A	-																	
513-405-10E	513-405-10A	513-405-10T	0.002	0.2	0-100-0	4	-	2	1	45	0.3 or less	<input checked="" type="checkbox"/>	<input checked="" type="checkbox"/>	<input checked="" type="checkbox"/>	<input checked="" type="checkbox"/>	<input checked="" type="checkbox"/>	<input checked="" type="checkbox"/>	<input checked="" type="checkbox"/>	
513-471-10E	-	-																	
513-475-10E	-	-	0.001	0.14	0-70-0	7	5	4	1	41	0.4 or less	<input checked="" type="checkbox"/>	<input checked="" type="checkbox"/>	<input checked="" type="checkbox"/>	<input checked="" type="checkbox"/>	<input checked="" type="checkbox"/>	<input checked="" type="checkbox"/>	<input checked="" type="checkbox"/>	
513-425-10E	513-425-10A	-																	
513-465-10E	-	-	0.002	0.2	0-100-0	4	-	3	1	45	0.3 or less	<input checked="" type="checkbox"/>	<input checked="" type="checkbox"/>	<input checked="" type="checkbox"/>	<input checked="" type="checkbox"/>	<input checked="" type="checkbox"/>	<input checked="" type="checkbox"/>		
513-401-10E	-	-																	

Order No.			Graduation (in)	Range (in)	Dial reading	Maximum permissible error (MPE)* (in)			Mass (g)	Measuring force (N)	High accuracy	With revolution counter	Long contact point	Standard	Double scale spacing	Compact	Carbide contact point	Ruby contact point
Basic set	Plus set	Full set				One rev.	Hysteresis	Repeatability										
513-402-10E	-	513-402-10T	0.0005	0.03	0-15-0	±0.0005	0.0002	±0.0002	45	0.3 or less	<input checked="" type="checkbox"/>	<input checked="" type="checkbox"/>	<input checked="" type="checkbox"/>	<input checked="" type="checkbox"/>	<input checked="" type="checkbox"/>	<input checked="" type="checkbox"/>	<input checked="" type="checkbox"/>	<input checked="" type="checkbox"/>
513-472-10E	-	-																
513-412-10E	-	513-412-10T																
513-479-10E	-	-																
513-462-10E	-	-	0.0001	0.008	0-4-0	±0.0001	0.0001	±0.00004	45	0.3 or less	<input checked="" type="checkbox"/>	<input checked="" type="checkbox"/>	<input checked="" type="checkbox"/>	<input checked="" type="checkbox"/>	<input checked="" type="checkbox"/>	<input checked="" type="checkbox"/>	<input checked="" type="checkbox"/>	<input checked="" type="checkbox"/>
513-403-10E	-	513-403-10T																
513-473-10E	-	-																
513-463-10E	-	-																

Order No.			Graduation	Range	Dial reading	Maximum permissible error (MPE)* (μm)				Mass (g)	Measuring force (N)	High accuracy	With revolution counter	Long contact point	Standard	Double scale spacing	Compact	Carbide contact point	Ruby contact point
Basic set	Plus set	Full set				Measuring range	10 scale divisions	Hysteresis	Repeatability										
513-409-10E	-	513-409-10T	0.002 mm / 0.0001 in	0.2 mm / 0.0076 in	0-10-0 / 0-38-0	4	2	3	1	45	0.3 or less	<input checked="" type="checkbox"/>	<input checked="" type="checkbox"/>	<input checked="" type="checkbox"/>	<input checked="" type="checkbox"/>	<input checked="" type="checkbox"/>	<input checked="" type="checkbox"/>	<input checked="" type="checkbox"/>	<input checked="" type="checkbox"/>

Order No.			Graduation	Range	Dial reading	Maximum permissible error (MPE)* (in)			Mass (g)	Measuring force (N)	High accuracy	With revolution counter	Long contact point	Standard	Double scale spacing	Compact	Carbide contact point	Ruby contact point
Basic set	Plus set	Full set				One rev.	Hysteresis	Repeatability										
513-406-10E	-	513-406-10T	0.0005 in / 0.01 mm	0.03 in / 0.7 mm	0-15-0 / 0-35-0	±0.0005	0.0002	±0.0002	45	0.3 or less	<input checked="" type="checkbox"/>	<input checked="" type="checkbox"/>	<input checked="" type="checkbox"/>	<input checked="" type="checkbox"/>	<input checked="" type="checkbox"/>	<input checked="" type="checkbox"/>	<input checked="" type="checkbox"/>	<input checked="" type="checkbox"/>

* We guarantee the accuracy of completed products by inspecting them with the dial face facing upward.

Note 1: Be sure to perform calibration with reference gage, etc. after exchanging the contact point. The inside parts may be damaged when the contact point is exchanged due to the breakage.

In the case the of the significant deterioration in the operation, repair is required.

Note 2: Stem with dovetail groove is not included in the mass.

Note 3: 513-4XX-10 is indicated on the dial face. But the Order No. for the Special Set provided with the stem etc. has a suffix (E or T) at the end.



Parallel (The scale can be read from the front, with the contact point pivoting in a plane parallel to that of the dial face)

Metric





17.4

**513-484-10E/513-484-10A/
513-484-10T**
Contact point No. 103006



Graduation: 0.01 mm
Range: 0.8 mm

 Carbide contact point





15.2

513-485-10E
Contact point No. 103011



Graduation: 0.002 mm
Range: 0.2 mm

 Carbide contact point





18.7

513-486-10E
Contact point No. 137557



Graduation: 0.01 mm
Range: 0.5 mm

 Double scale spacing
 Carbide contact point

Inch



0.65 in

513-482-10A/513-482-10T
Contact point No. 133195



Graduation: 0.0005 in
Range: 0.03 in

 Carbide contact point

SPECIFICATIONS

Order No.			Graduation (mm)	Range (mm)	Dial reading	Maximum permissible error (MPE)* (μm)				Mass (g)	Measuring force (N)	High accuracy	With revolution counter	Long contact point	Standard	Double scale spacing	Compact	Carbide contact point	Ruby contact point		
Basic set	Plus set	Full set				Measuring range	10 scale divisions	Hysteresis	Repeatability												
513-484-10E	513-484-10A	513-484-10T	0.01	0.8	0-40-0	9	5	4	3	53	0.3 or less	<input checked="" type="checkbox"/>	<input checked="" type="checkbox"/>	<input type="checkbox"/>	<input type="checkbox"/>	<input type="checkbox"/>	<input type="checkbox"/>	<input type="checkbox"/>	<input type="checkbox"/>		
513-485-10E	-	-	0.002	0.2	0-100-0	4	2	3	1			<input type="checkbox"/>	<input type="checkbox"/>	<input type="checkbox"/>	<input type="checkbox"/>	<input type="checkbox"/>	<input type="checkbox"/>	<input type="checkbox"/>	<input type="checkbox"/>	<input checked="" type="checkbox"/>	<input type="checkbox"/>
513-486-10E	-	-	0.01	0.5	0-25-0	6	5	4	3			<input type="checkbox"/>	<input type="checkbox"/>	<input type="checkbox"/>	<input checked="" type="checkbox"/>	<input type="checkbox"/>	<input type="checkbox"/>	<input checked="" type="checkbox"/>	<input type="checkbox"/>	<input type="checkbox"/>	

Order No.			Graduation (in)	Range (in)	Dial reading	Maximum permissible error (MPE)* (in)			Mass (g)	Measuring force (N)	High accuracy	With revolution counter	Long contact point	Standard	Double scale spacing	Compact	Carbide contact point	Ruby contact point
Basic set	Plus set	Full set				One rev.	Hysteresis	Repeatability										
-	513-482-10A	513-482-10T	0.0005	0.03	0-15-0	±0.0005	0.0002	±0.0002	53	0.3 or less	<input checked="" type="checkbox"/>	<input checked="" type="checkbox"/>	<input type="checkbox"/>	<input type="checkbox"/>	<input type="checkbox"/>	<input type="checkbox"/>	<input checked="" type="checkbox"/>	<input type="checkbox"/>

* We guarantee the accuracy of completed products by inspecting them with the dial face vertical.
 Note 1: Be sure to perform calibration with reference gage, etc. after exchanging the contact point. The inside parts may be damaged when the contact point is exchanged due to the breakage. In the case the of the significant deterioration in the operation, repair is required.
 Note 2: Stem with dovetail groove is not included in the mass.
 Note 3: **513-4XX-10** is indicated on the dial face. But the Order No. for the Special Set provided with the stem etc. has a suffix (E or T) at the end.

DIMENSIONS

* No dovetail in the back.

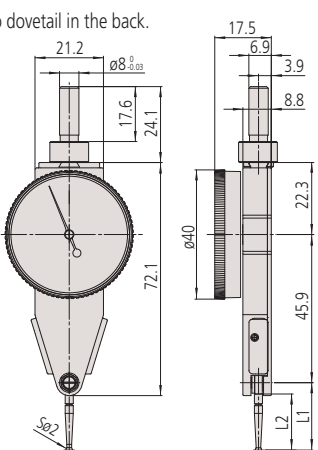

Unit: mm

Order No.	L1	L2
513-484-10E	20.9	17.4
513-485-10E	18.7	15.2
513-486-10E	22.2	18.7

Note: A slight difference may occur depending on the center of the contact point, graduation plate, and stem fixing position, etc.



Vertical (Best suited for centering holes under the spindle of a machine tool)

Metric



Graduation: 0.01 mm
Range: 0.8 mm

Carbide contact point

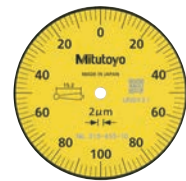

Graduation: 0.002 mm
Range: 0.2 mm

Carbide contact point

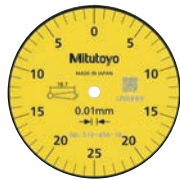

Graduation: 0.01 mm
Range: 0.5 mm

Double scale spacing

Carbide contact point

Inch



Graduation: 0.0005 in
Range: 0.03 in

Carbide contact point



Graduation: 0.0001 in
Range: 0.008 in

Carbide contact point

SPECIFICATIONS

Order No.			Graduation (mm)	Range (mm)	Dial reading	Maximum permissible error (MPE)* (μm)				Mass (g)	Measuring force (N)	High accuracy	With revolution counter	Long contact point	Standard	Double scale spacing	Compact	Carbide contact point	Ruby contact point		
Basic set	Plus set	Full set				Measuring range	10 scale divisions	Hysteresis	Repetability												
513-454-10E	513-454-10A	513-454-10T	0.01	0.8	0-40-0	9	5	4	3	46	0.3 or less	<input checked="" type="checkbox"/>	<input checked="" type="checkbox"/>	<input checked="" type="checkbox"/>	<input checked="" type="checkbox"/>	<input checked="" type="checkbox"/>	<input checked="" type="checkbox"/>	<input checked="" type="checkbox"/>	<input checked="" type="checkbox"/>		
513-455-10E	513-455-10A	513-455-10T	0.002	0.2	0-100-0	4	2	3	1			<input type="checkbox"/>	<input type="checkbox"/>	<input type="checkbox"/>	<input type="checkbox"/>	<input type="checkbox"/>	<input type="checkbox"/>	<input type="checkbox"/>	<input type="checkbox"/>	<input type="checkbox"/>	<input type="checkbox"/>
513-456-10E	-	-	0.01	0.5	0-25-0	6	5	4	3			<input type="checkbox"/>	<input type="checkbox"/>	<input type="checkbox"/>	<input checked="" type="checkbox"/>	<input type="checkbox"/>	<input type="checkbox"/>	<input type="checkbox"/>	<input checked="" type="checkbox"/>	<input checked="" type="checkbox"/>	

Order No.			Graduation (in)	Range (in)	Dial reading	Maximum permissible error (MPE)* (in)			Mass (g)	Measuring force (N)	High accuracy	With revolution counter	Long contact point	Standard	Double scale spacing	Compact	Carbide contact point	Ruby contact point
Basic set	Plus set	Full set				One rev.	Hysteresis	Repetability										
513-452-10E	-	513-452-10T	0.0005	0.03	0-15-0	±0.0005	0.0002	±0.0002	46	0.3 or less	<input checked="" type="checkbox"/>	<input checked="" type="checkbox"/>	<input checked="" type="checkbox"/>	<input checked="" type="checkbox"/>	<input checked="" type="checkbox"/>	<input checked="" type="checkbox"/>	<input checked="" type="checkbox"/>	<input checked="" type="checkbox"/>
513-453-10E	-	513-453-10T	0.0001	0.008	0-4-0	±0.0001	0.0001	±0.00004			<input type="checkbox"/>	<input type="checkbox"/>	<input type="checkbox"/>	<input type="checkbox"/>	<input type="checkbox"/>	<input type="checkbox"/>	<input type="checkbox"/>	<input type="checkbox"/>

* We guarantee the accuracy of completed products by inspecting them with the dial face facing upward.

Note 1: Be sure to perform calibration with reference gage, etc. after exchanging the contact point. The inside parts may be damaged when the contact point is exchanged due to the breakage.

In the case of the significant deterioration in the operation, repair is required.

Note 2: Stem with dovetail groove is not included in the mass.

Note 3: **513-4XX-10** is indicated on the dial face. But the Order No. for the Special Set provided with the stem etc. has a suffix (E or T) at the end.

DIMENSIONS

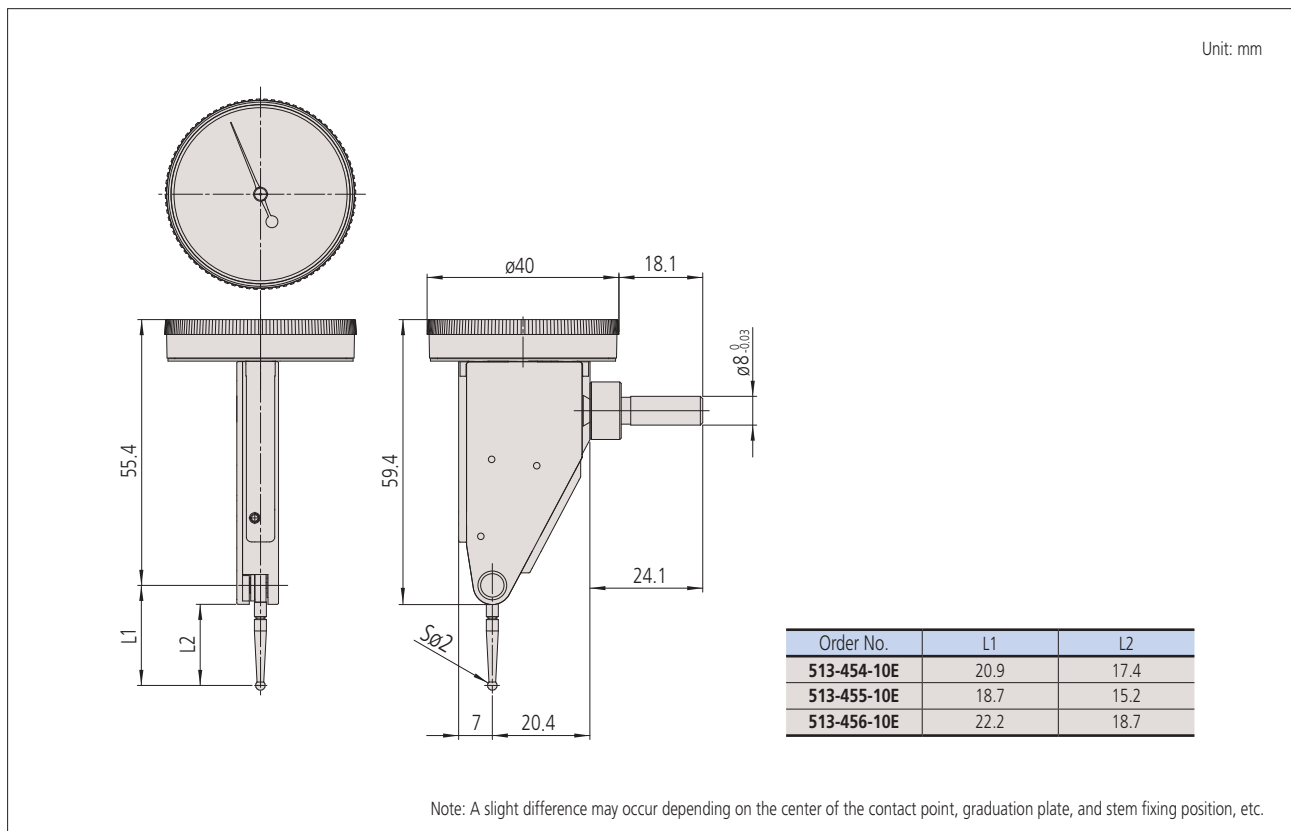



Horizontal (20° Tilted Face) (Dial face inclined 20°, compared with the vertical type, allows easy reading)

Metric

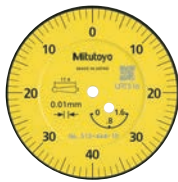

Graduation: 0.01 mm
Range: 1.6 mm

- With revolution counter
- Carbide contact point

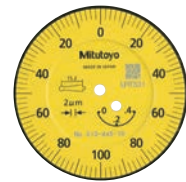

Graduation: 0.002 mm
Range: 0.4 mm

- With revolution counter
- Carbide contact point

Inch



Graduation: 0.0005 in
Range: 0.06 in

- With revolution counter
- Carbide contact point

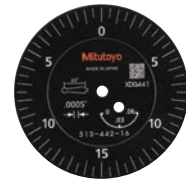

Graduation: 0.0005 in
Range: 0.06 in

- With revolution counter
- Carbide contact point



Graduation: 0.0005 in
Range: 0.06 in

- With revolution counter
- Long contact point
- Carbide contact point



Graduation: 0.0005 in
Range: 0.06 in

- With revolution counter
- Long contact point
- Carbide contact point



Graduation: 0.0001 in
Range: 0.016 in

- With revolution counter
- Carbide contact point



Graduation: 0.0001 in
Range: 0.016 in

- With revolution counter
- Carbide contact point

SPECIFICATIONS

Order No.			Graduation (mm)	Range (mm)	Dial reading	Maximum permissible error (MPE)* (μm)					Mass (g)	Measuring force (N)	High accuracy	With revolution counter	Long contact point	Standard	Double scale spacing	Compact	Carbide contact point	Ruby contact point
Basic set	Plus set	Full set				Measuring range	One rev.	10 scale divisions	Hysteresis	Repeatability										
513-444-10E	513-444-10A	513-444-10T	0.01	1.6	0-40-0	16	10	5	5	3	48	0.3 or less	<input checked="" type="checkbox"/>	<input checked="" type="checkbox"/>	<input type="checkbox"/>	<input type="checkbox"/>	<input type="checkbox"/>	<input type="checkbox"/>	<input checked="" type="checkbox"/>	<input type="checkbox"/>
513-445-10E	513-445-10A	513-445-10T	0.002	0.4	0-100-0	6	5	2	4	1			<input checked="" type="checkbox"/>	<input type="checkbox"/>	<input type="checkbox"/>	<input type="checkbox"/>	<input type="checkbox"/>	<input type="checkbox"/>	<input checked="" type="checkbox"/>	<input type="checkbox"/>

Order No.			Graduation (in)	Range (in)	Dial reading	Maximum permissible error (MPE)* (in)				Mass (g)	Measuring force (N)	High accuracy	With revolution counter	Long contact point	Standard	Double scale spacing	Compact	Carbide contact point	Ruby contact point
Basic set	Plus set	Full set				One rev.	First 2.5 rev.	Hysteresis	Repeatability										
-	513-442-10A	513-442-10T	0.0005	0.06	0-15-0	±0.0005	±0.0005	0.0002	±0.0002	48	0.3 or less	<input checked="" type="checkbox"/>	<input checked="" type="checkbox"/>	<input type="checkbox"/>	<input type="checkbox"/>	<input type="checkbox"/>	<input type="checkbox"/>	<input checked="" type="checkbox"/>	<input type="checkbox"/>
-	513-442-16A	513-442-16T										<input checked="" type="checkbox"/>	<input checked="" type="checkbox"/>	<input type="checkbox"/>	<input type="checkbox"/>	<input checked="" type="checkbox"/>	<input type="checkbox"/>		
-	513-446-10A	513-446-10T	<input checked="" type="checkbox"/>	<input checked="" type="checkbox"/>	<input type="checkbox"/>	<input type="checkbox"/>	<input checked="" type="checkbox"/>	<input type="checkbox"/>											
-	513-446-16A	513-446-16T	<input checked="" type="checkbox"/>	<input checked="" type="checkbox"/>	<input type="checkbox"/>	<input type="checkbox"/>	<input checked="" type="checkbox"/>	<input type="checkbox"/>											
-	513-443-10A	513-443-10T	0.0001	0.016	0-4-0	±0.0002	±0.0002	0.0001	±0.00004	48	0.3 or less	<input checked="" type="checkbox"/>	<input checked="" type="checkbox"/>	<input type="checkbox"/>	<input type="checkbox"/>	<input type="checkbox"/>	<input type="checkbox"/>	<input checked="" type="checkbox"/>	<input type="checkbox"/>
-	513-443-16A	513-443-16T										<input checked="" type="checkbox"/>	<input checked="" type="checkbox"/>	<input type="checkbox"/>	<input type="checkbox"/>	<input checked="" type="checkbox"/>	<input type="checkbox"/>		

* We guarantee the accuracy of completed products by inspecting them with the dial face facing upward.

Note 1: Be sure to perform calibration with reference gage, etc. after exchanging the contact point. The inside parts may be damaged when the contact point is exchanged due to the breakage.

In the case of the significant deterioration in the operation, repair is required.

Note 2: Stem with dovetail groove is not included in the mass.

Note 3: 513-4XX-10 is indicated on the dial face. But the Order No. for the Special Set provided with the stem etc. has a suffix (E or T) at the end.

DIMENSIONS

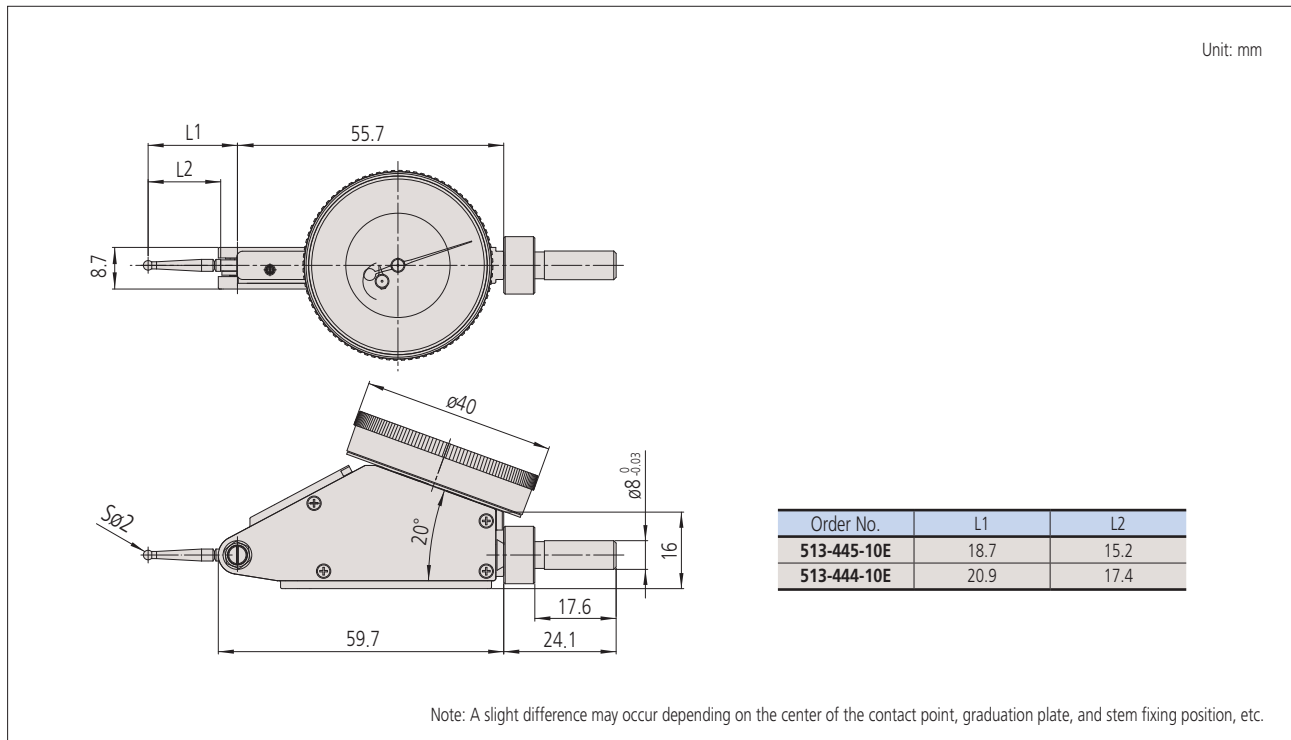



Pocket Type (Slim design is suited for measurement in deep holes)

Clutch type (with a clutch lever)



Metric

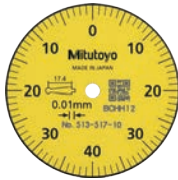

Graduation: 0.01 mm
Range: 0.8 mm

- Standard
- Compact
- Carbide contact point

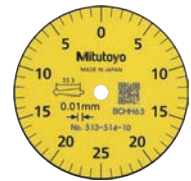

Graduation: 0.01 mm
Range: 0.5 mm

- Long contact point
- Double scale spacing
- Compact
- Carbide contact point

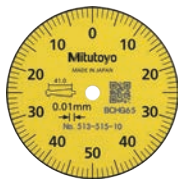

Graduation: 0.01 mm
Range: 1 mm

- Long contact point
- Compact
- Carbide contact point

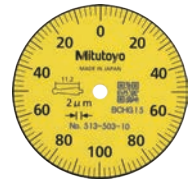

Graduation: 0.002 mm
Range: 0.2 mm

- Standard
- Compact
- Carbide contact point

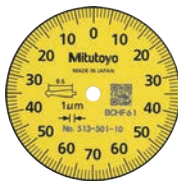

Graduation: 0.001 mm
Range: 0.14 mm

- High accuracy
- Compact
- Carbide contact point

Inch

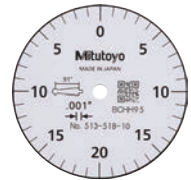

Graduation: 0.001 in
Range: 0.04 in

- Compact
- Carbide contact point

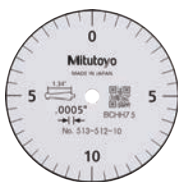

Graduation: 0.0005 in
Range: 0.02 in

- Long contact point
- Double scale spacing
- Compact
- Carbide contact point



Graduation: 0.0001 in
Range: 0.01 in

- Compact
- Carbide contact point

SPECIFICATIONS

Order No.		Graduation (mm)	Range (mm)	Dial reading	Maximum permissible error (MPE)* (μm)					Mass (g)	Measuring force (N)	High accuracy	With revolution counter	Long contact point	Standard	Double scale spacing	Compact	Carbide contact point	Ruby contact point
Basic set	Full set				Measuring range	One rev.	10 scale divisions	Hysteresis	Repeatability										
513-517-10E	513-517-10T	0.01	0.8	0-40-0	9	-	5	4	3	50	0.3 or less	<input checked="" type="checkbox"/>	<input checked="" type="checkbox"/>	<input type="checkbox"/>	<input checked="" type="checkbox"/>	<input checked="" type="checkbox"/>	<input checked="" type="checkbox"/>	<input checked="" type="checkbox"/>	<input checked="" type="checkbox"/>
513-514-10E	513-514-10T	0.01	0.5	0-25-0	10	-	5	5	3	51	0.3 or less	<input type="checkbox"/>	<input type="checkbox"/>	<input checked="" type="checkbox"/>	<input checked="" type="checkbox"/>	<input checked="" type="checkbox"/>	<input checked="" type="checkbox"/>	<input checked="" type="checkbox"/>	<input checked="" type="checkbox"/>
513-515-10E	513-515-10T	0.01	1	0-50-0	10	-	5	5	3	51	0.3 or less	<input type="checkbox"/>	<input checked="" type="checkbox"/>	<input type="checkbox"/>	<input checked="" type="checkbox"/>	<input checked="" type="checkbox"/>	<input checked="" type="checkbox"/>	<input checked="" type="checkbox"/>	<input checked="" type="checkbox"/>
513-503-10E	513-503-10T	0.002	0.2	0-100-0	4	-	2	3	1	50	0.4 or less	<input type="checkbox"/>	<input type="checkbox"/>	<input checked="" type="checkbox"/>	<input type="checkbox"/>	<input checked="" type="checkbox"/>	<input checked="" type="checkbox"/>	<input checked="" type="checkbox"/>	<input checked="" type="checkbox"/>
513-501-10E	513-501-10T	0.001	0.14	0-70-0	4	-	2	3	1	50	0.5 or less	<input checked="" type="checkbox"/>	<input type="checkbox"/>	<input type="checkbox"/>	<input checked="" type="checkbox"/>	<input type="checkbox"/>	<input checked="" type="checkbox"/>	<input checked="" type="checkbox"/>	<input checked="" type="checkbox"/>

Order No.		Graduation (in)	Range (in)	Dial reading	Maximum permissible error (MPE)* (in)				Mass (g)	Measuring force (N)	High accuracy	With revolution counter	Long contact point	Standard	Double scale spacing	Compact	Carbide contact point	Ruby contact point
Basic set	Full set				One rev.	First 2.5 rev.	Hysteresis	Repeatability										
513-518-10E	513-518-10T	0.001	0.04	0-20-0	±0.001	-	0.0002	±0.0004	50	0.3 or less	<input checked="" type="checkbox"/>	<input checked="" type="checkbox"/>	<input type="checkbox"/>	<input type="checkbox"/>	<input type="checkbox"/>	<input checked="" type="checkbox"/>	<input checked="" type="checkbox"/>	<input checked="" type="checkbox"/>
513-512-10E	513-512-10T	0.0005	0.02	0-10-0	±0.0005	-	0.0002	±0.0002	51	0.3 or less	<input type="checkbox"/>	<input checked="" type="checkbox"/>	<input type="checkbox"/>	<input checked="" type="checkbox"/>	<input checked="" type="checkbox"/>	<input checked="" type="checkbox"/>	<input checked="" type="checkbox"/>	<input checked="" type="checkbox"/>
513-504-10E	513-504-10T	0.0001	0.01	0-5-0	±0.0002	-	0.0001	±0.0004	50	0.3 or less	<input type="checkbox"/>	<input type="checkbox"/>	<input type="checkbox"/>	<input checked="" type="checkbox"/>	<input checked="" type="checkbox"/>	<input checked="" type="checkbox"/>	<input checked="" type="checkbox"/>	<input checked="" type="checkbox"/>

* We guarantee the accuracy of completed products by inspecting them with the dial face facing upward.

Note 1: Be sure to perform calibration with reference gage, etc. after exchanging the contact point. The inside parts may be damaged when the contact point is exchanged due to the breakage. In the case the of the significant deterioration in the operation, repair is required.

Note 2: Stem is not included in the mass.

Note 3: 513-5XX-10 is indicated on the dial face. But the Order No. for the Special Set provided with the stem etc. has a suffix (E or T) at the end.

DIMENSIONS

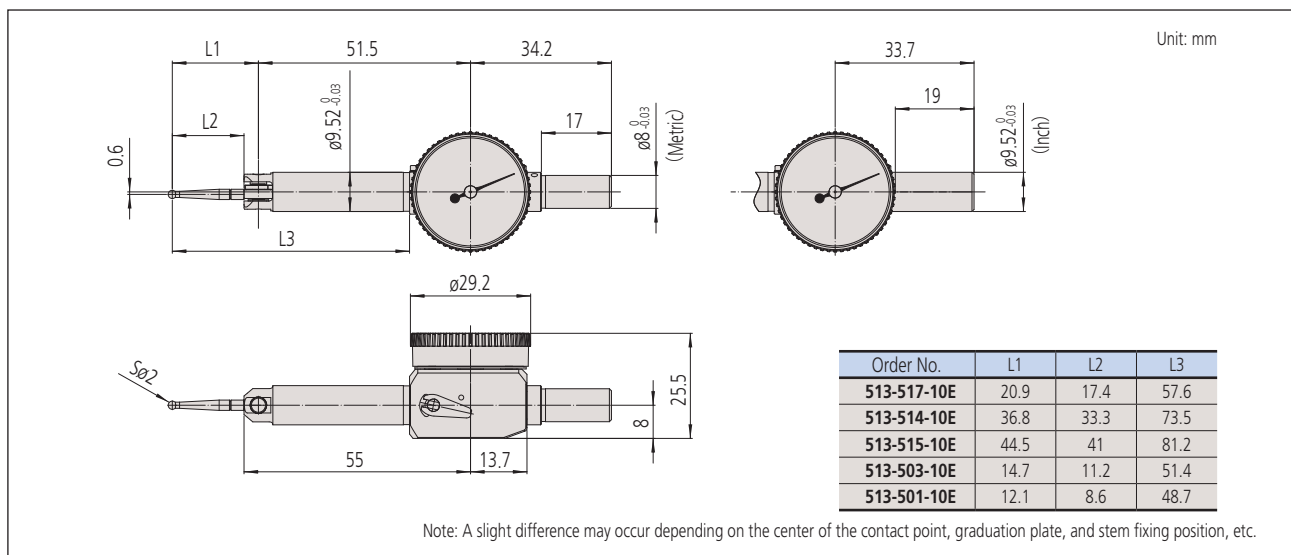

Pocket type can be fixed at the body (at $\varnothing 9.52$)

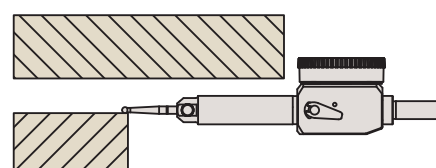

The slim body allows measurements in shallow space.

Set configuration



Horizontal



Horizontal (20° tilted face)



Parallel



Vertical



Pocket type

Metric and Metric/Inch

Full set

Swivel clamp (900321, for ø4 mm stem, ø8 mm stem, and dovetail) Metric holding bar (L: 100 mm)

Plus set

ø1 mm contact point (carbide) ø3 mm contact point (carbide) Stem, ø4 mm

Basic set

ø2 mm contact point (carbide) Indicator Knurled clamp ring Stem, ø8 mm

T set

A set

E set

H set (ø 6 Stem)

Metric

Full set

Swivel clamp (900321, for ø4 mm stem, ø8 mm stem, and dovetail) Metric holding bar (L: 100 mm)

Plus set

ø1 mm contact point (carbide) ø3 mm contact point (carbide) Stem, ø4 mm

Basic set

ø2 mm contact point (carbide) Indicator Knurled clamp ring Stem, ø8 mm

T set

A set

E set

H set (ø 6 Stem)

Metric

Full set

Swivel clamp (900321, for ø4 mm, ø8 mm, dovetail) Metric holding bar (L: 100 mm) Stem, ø4 mm ø8 mm holding bar (900211)

Basic set

ø2 mm contact point (carbide) Indicator Stem, ø8 mm Spanner (301336)

T set

E set

Inch and Inch/Metric

Full set

0.039 inch DIA. contact point (carbide) 0.118 inch DIA. contact point (carbide) Stem, 0.157 inch DIA. Swivel clamp (900322, for 0.157 inch DIA. stem, 0.375 inch DIA. stem, and dovetail) Inch holding bar (L: 4 in)

Basic set

0.079 inch DIA. contact point (carbide) Indicator Knurled clamp ring Stem, 0.375 inch DIA.

T set

E set

Inch

Full set

Swivel clamp (900322, for 0.157 inch DIA. stem, 0.375 inch DIA. stem, and dovetail) Inch holding bar (L: 4 in)

Plus set

0.039 inch DIA. contact point (carbide) 0.118 inch DIA. contact point (carbide) Stem, 0.157 inch DIA.

Basic set

Indicator 0.079 inch DIA. contact point (carbide) Knurled clamp ring Stem, 0.375 inch DIA.

T set

E set

Inch

Full set

0.039 inch DIA. contact point (carbide) 0.118 inch DIA. contact point (carbide) Stem, 0.157 inch DIA. Swivel clamp (900322, for 0.157 inch DIA., 0.375 inch DIA., dovetail) Inch holding bar (L: 4 in) 0.315 inch DIA. holding bar (900211)

Basic set

0.079 inch DIA. contact point (carbide) Indicator Stem, 0.375 inch DIA. Spanner (301336)

T set

E set

External dimensions of contact points for dial test indicators

The length of the contact point is specific to each indicator model. Always use the contact point designed for your model.

	L2 (mm)	øD (mm)						Applicable model
		ø0.5 steel	ø0.7 steel	ø1 carbide	ø2 carbide	ø2 ruby	ø3 carbide	
	8.6	–	–	136756	136104	–	136758	513-501-10E, 513-501-10T
	11.2	190547	190548	103017	103010	21CZA209	103018	513-401-10E, 513-471-10E, 513-503-10E, 513-503-10T
	15.2	21CAB109	21CAB110	131314	103011	21CZB068	131315	513-405-10A, 513-405-10E, 513-404-10T, 513-425-10A, 513-425-10E, 513-465-10E, 513-445-10A, 513-445-10E, 513-445-10T, 513-455-10A, 513-455-10E, 513-455-10T, 513-475-10E, 513-485-10E
	17.4	190549	190550	103013	103006	21CZA201	103014	513-404-10A, 513-404-10E, 513-404-10T, 513-464-10E, 513-444-10A, 513-444-10E, 513-444-10T, 513-454-10A, 513-454-10E, 513-454-10T 513-484-10A, 513-484-10E, 513-484-10T, 513-474-10E, 513-517-10E, 513-517-10T
	18.7	190654	190653	137558	137557	21CZA210	137559	513-424-10A, 513-424-10E, 513-424-10T, 513-456-10E, 513-466-10E, 513-426-10A, 513-426-10E 513-478-10E, 513-486-10E
	33.3	–	–	137746	129949	–	137747	513-514-10E, 513-514-10T
	33.9	21CAB111	21CAB112	131316	131324	–	131317	513-414-10A, 513-414-10E, 513-414-10T
	41.0	190656	190655	136235	136013	21CZA211	136236	513-415-10A, 513-415-10E, 513-415-10T, 513-477-10E, 513-515-10E, 513-515-10T

Note: Carbide contact point is slightly magnetic. ø1 and ø3 contact points with non-conductive ruby ball which can be used for EDM machines are available by special order.

Contact point replacement

- To remove a contact point, wrap a soft waste cloth around the contact point and rotate it slowly while being pinched with pliers so as not to cause a scratch on it.
- After replacement of a contact point, the indicator must be calibrated against a reference. If a contact point is bent or broken, inner components might be damaged. In case of significant deterioration of accuracy or performance, the indicator needs to be repaired.
- Recommended tightening torque: 0.16 N·m

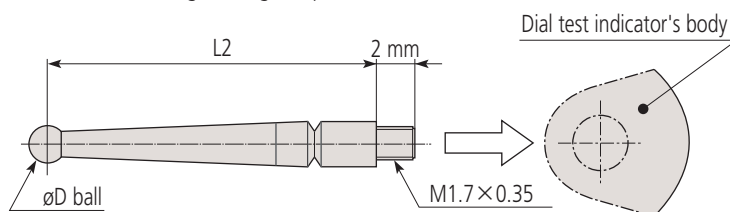



Whatever your challenges are, Mitutoyo supports you from start to finish.

Mitutoyo is not only a manufacturer of top quality measuring products but one that also offers qualified support for the lifetime of the equipment, backed by comprehensive services that ensure your staff can make the very best use of the investment.

Apart from the basics of calibration and repair, Mitutoyo offers product and metrology training, as well as IT support for the sophisticated software used in modern measuring technology. We can also design, build, test and deliver measuring solutions and even, if deemed cost-effective, take your critical measurement challenges in-house on a sub-contract basis.



Find additional product literature and our product catalog

www.mitutoyo.com

Note: All information regarding our products, and in particular the illustrations, drawings, dimensional and performance data contained in this printed matter as well as other technical data are to be regarded as approximate average values. We therefore reserve the right to make changes to the corresponding designs. The stated standards, similar technical regulations, descriptions and illustrations of the products were valid at the time of printing. In addition, the latest applicable version of our General Trading Conditions will apply. Only quotations submitted by ourselves may be regarded as definitive. Specifications are subject to change without notice.

Mitutoyo products are subject to US Export Administration Regulations (EAR). Re-export or relocation of our products may require prior approval by an appropriate governing authority.

Trademarks and Registrations

Designations used by companies to distinguish their products are often claimed as trademarks. In all instances where Mitutoyo America Corporation is aware of a claim, the product names appear in initial capital or all capital letters. The appropriate companies should be contacted for more complete trademark and registration information.



Mitutoyo America Corporation

www.mitutoyo.com
 One Number to Serve You Better
 1-888-MITUTOYO (1-888-648-8869)

M³ Solution Centers:

- Aurora, Illinois (Headquarters)
- Boston, Massachusetts
- Charlotte, North Carolina
- Cincinnati, Ohio
- Detroit, Michigan
- Los Angeles, California
- Seattle, Washington
- Houston, Texas