



PicoScope® 6000E Series

(ps6000a API)

Programmer's Guide

Contents

1 Introduction	6
1 Software license conditions	7
2 Trademarks	7
2 Programming overview	8
1 System requirements	8
2 Driver	9
3 Voltage ranges	10
4 MSO digital data	11
5 Triggering	12
6 Sampling modes	13
1 Block mode	13
2 Rapid block mode	16
3 Streaming mode	21
4 Retrieving stored data	23
7 Timebases	23
8 Combining several oscilloscopes	24
9 Handling intelligent probe interactions	25
3 API functions	26
1 ps6000aChannelCombinationsStateless - get possible channel combinations	27
2 ps6000aCheckForUpdate - is firmware update available?	28
3 ps6000aCloseUnit - close a scope device	29
4 ps6000aEnumerateUnits - get a list of unopened units	30
5 ps6000aFlashLed - flash the front-panel LED	31
6 ps6000aGetAccessoryInfo - get information about a connected accessory	32
7 ps6000aGetAdcLimits - get min and max sample values	33
8 ps6000aGetAnalogueOffsetLimits - get analog offset information	34
9 ps6000aGetDeviceResolution - retrieve the device resolution	35
10 ps6000aGetMaximumAvailableMemory - depending on hardware resolution	36
11 ps6000aGetMinimumTimebaseStateless - find fastest available timebase	37
12 ps6000aGetNoOfCaptures - query how many captures made	38
13 ps6000aGetNoOfProcessedCaptures - query how many captures processed	39
14 ps6000aGetStreamingLatestValues - read streaming data	40
1 PICO_STREAMING_DATA_INFO	41
2 PICO_STREAMING_DATA_TRIGGER_INFO	42
15 ps6000aGetTimebase - get available timebases	43
16 ps6000aGetTriggerInfo - get trigger timing information	44
1 PICO_TRIGGER_INFO	45
17 ps6000aGetTriggerTimeOffset - get timing corrections	46
18 ps6000aGetUnitInfo - get information about device	47

19 ps6000aGetValues - get block mode data	49
1 Downsampling modes	50
20 ps6000aGetValuesAsync - read data without blocking	51
21 ps6000aGetValuesBulk - read multiple segments	52
22 ps6000aGetValuesBulkAsync - read multiple segments without blocking	53
23 ps6000aGetValuesOverlapped - get rapid block data	54
1 Using GetValuesOverlapped()	55
24 ps6000aGetValuesTriggerTimeOffsetBulk - get trigger time offsets for multiple segments	56
25 ps6000aIsReady - get status of block capture	57
26 ps6000aMemorySegments - set number of memory segments	58
27 ps6000aMemorySegmentsBySamples - set size of memory segments	59
28 ps6000aNearestSampleIntervalStateless - get nearest sampling interval	60
29 ps6000aNoOfStreamingValues - get number of captured samples	61
30 ps6000aOpenUnit - open a scope device	62
31 ps6000aOpenUnitAsync - open unit without blocking	63
32 ps6000aOpenUnitProgress - get status of opening a unit	64
33 ps6000aPingUnit - check if device is still connected	65
34 ps6000aQueryMaxSegmentsBySamples - get number of segments	66
35 ps6000aQueryOutputEdgeDetect - check if output edge detection is enabled	67
36 ps6000aResetChannelsAndReportAllChannelsOvervoltageTripStatus	68
37 ps6000aReportAllChannelsOvervoltageTripStatus	68
1 PICO_CHANNEL_OVERVOLTAGE_TRIPPED structure	69
38 ps6000aRunBlock - start block mode capture	70
39 ps6000aRunStreaming - start streaming mode capture	72
40 ps6000aSetChannelOff - disable one channel	74
41 ps6000aSetChannelOn - enable and set options for one channel	75
42 ps6000aSetDataBuffer - provide location of data buffer	77
43 ps6000aSetDataBuffers - provide locations of both data buffers	79
44 ps6000aSetDeviceResolution - set the hardware resolution	80
1 PICO_DEVICE_RESOLUTION enumerated type	80
45 ps6000aSetDigitalPortOff - switch off digital inputs	81
46 ps6000aSetDigitalPortOn - set up and enable digital inputs	82
47 ps6000aSetExternalReferenceInteractionCallback - register callback function for external reference clock events	83
48 ps6000aSetNoOfCaptures - modify rapid block mode	84
49 ps6000aSetOutputEdgeDetect - change triggering behavior	85
50 ps6000aSetProbeInteractionCallback - register callback function for probe events	86
51 ps6000aSetPulseWidthDigitalPortProperties - set digital port pulse width	87
52 ps6000aSetPulseWidthQualifierConditions - specify how to combine channels	88
53 ps6000aSetPulseWidthQualifierDirections - specify threshold directions	89
54 ps6000aSetPulseWidthQualifierProperties - specify threshold logic	90
55 ps6000aSetSimpleTrigger - set up triggering	91
56 ps6000aSetTriggerChannelConditions - set triggering logic	92

1 PICO_CONDITION structure	93
57 ps6000aSetTriggerChannelDirections - set trigger directions	94
1 PICO_DIRECTION structure	95
58 ps6000aSetTriggerChannelProperties - set up triggering	96
1 TRIGGER_CHANNEL_PROPERTIES structure	97
59 ps6000aSetTriggerDelay - set post-trigger delay	98
60 ps6000aSetTriggerDigitalPortProperties - set port directions	99
1 PICO_DIGITAL_CHANNEL_DIRECTIONS structure	100
61 ps6000aSigGenApply - set output parameters	101
62 ps6000aSigGenClockManual - control signal generator clock	103
63 ps6000aSigGenFilter - switch output filter on or off	104
64 ps6000aSigGenFrequency - set output frequency	105
65 ps6000aSigGenFrequencyLimits - get limits in sweep mode	106
66 ps6000aSigGenFrequencySweep - set signal generator to frequency sweep mode	107
67 ps6000aSigGenLimits - get signal generator parameters	108
68 ps6000aSigGenPause - stop the signal generator	109
69 ps6000aSigGenPhase - set signal generator using delta-phase	110
1 Calculating deltaPhase	110
70 ps6000aSigGenPhaseSweep - set signal generator to sweep using delta-phase	112
71 ps6000aSigGenRange - set signal generator output voltages	113
72 ps6000aSigGenRestart - continue after pause	114
73 ps6000aSigGenSoftwareTriggerControl - set software triggering	115
74 ps6000aSigGenTrigger - choose the trigger event	116
75 ps6000aSigGenWaveform - choose signal generator waveform	117
76 ps6000aSigGenWaveformDutyCycle - set duty cycle	118
77 ps6000aStartFirmwareUpdate - update the device firmware	119
78 ps6000aStop - stop sampling	120
79 ps6000aStopUsingGetValuesOverlapped - complements ps6000aGetValuesOverlapped	121
80 ps6000aTriggerWithinPreTriggerSamples - switch feature on or off	122
4 Callbacks	123
1 ps6000aBlockReady - indicate when block-mode data ready	123
2 ps6000aDataReady - indicate when post-collection data ready	124
3 PicoUpdateFirmwareProgress - get status of firmware update	125
4 PicoProbeInteractions() – callback for PicoConnect probe events	126
1 PICO_USER_PROBE_INTERACTIONS structure	127
5 PicoExternalReferenceInteractions () - callback for external reference clock events	129
1 PICO_CLOCK_REFERENCE enumerated type	130
5 Reference	131
1 Numeric data types	131
2 Enumerated types and constants	131
3 Driver status codes	132
4 Glossary	132

1 Introduction

The PicoScope 6000E Series of oscilloscopes from Pico Technology is a range of compact high-performance units designed to replace traditional benchtop oscilloscopes.

This manual explains how to use the ps6000a API (application programming interface) for the PicoScope 6000E Series scopes.

For more information on the hardware, see the *PicoScope 6000E Series Data Sheet*.



ps6000apg-5 (Available [online](#) and as a [PDF](#))

1.1 Software license conditions

The material contained in this release is licensed, not sold. Pico Technology Limited grants a license to the person who installs this software, subject to the conditions listed below.

Access. The licensee agrees to allow access to this software only to persons who have been informed of these conditions and agree to abide by them.

Usage. The software in this release is for use only with Pico Technology products or with data collected using Pico Technology products.

Copyright. Pico Technology Ltd. claims the copyright of, and retains the rights to, all material (software, documents, etc.) contained in this software development kit (SDK) except the example programs. You may copy and distribute the SDK without restriction, as long as you do not remove any Pico Technology copyright statements. The example programs in the SDK may be modified, copied and distributed for the purpose of developing programs to collect data using Pico products.

Liability. Pico Technology and its agents shall not be liable for any loss, damage or injury, howsoever caused, related to the use of Pico Technology equipment or software, unless excluded by statute.

Fitness for purpose. As no two applications are the same, Pico Technology cannot guarantee that its equipment or software is suitable for a given application. It is your responsibility, therefore, to ensure that the product is suitable for your application.

Mission-critical applications. This software is intended for use on a computer that may be running other software products. For this reason, one of the conditions of the license is that it excludes use in mission-critical applications, for example life support systems.

Viruses. This software was continuously monitored for viruses during production, but you are responsible for virus-checking the software once it is installed.

Support. If you are dissatisfied with the performance of this software, please contact our technical support staff, who will try to fix the problem within a reasonable time. If you are still dissatisfied, please return the product and software to your supplier within 14 days of purchase for a full refund.

Upgrades. We provide upgrades, free of charge, from our web site at www.picotech.com. We reserve the right to charge for updates or replacements sent out on physical media.

1.2 Trademarks

Pico Technology and **PicoScope** are trademarks of Pico Technology Limited, registered in the United Kingdom and other countries.

PicoScope and **Pico Technology** are registered in the U.S. Patent and Trademark Office.

Windows, **Excel** and **Visual Basic for Applications** are registered trademarks or trademarks of Microsoft Corporation in the USA and other countries. **LabVIEW** is a registered trademark of National Instruments Corporation. **MATLAB** is a registered trademark of The MathWorks, Inc.

2 Programming overview

The `ps6000a.dll` dynamic link library in the `lib` subdirectory of your Pico Technology SDK installation directory allows you to program a [PicoScope 6000E Series oscilloscope](#) using standard C [function calls](#).

A typical program for capturing data consists of the following steps:

- [Open](#) the scope unit.
- Set up the input channels with the required [voltage ranges](#) and [coupling type](#).
- Set up [triggering](#).
- Start capturing data. (See [Sampling modes](#), where programming is discussed in more detail.)
- Wait until the scope unit is ready.
- Stop capturing data.
- Copy data to a buffer.
- Close the scope unit.

Numerous sample programs are available on the [picotech](#) channel of GitHub. These demonstrate how to use the functions of the driver software in each of the modes available.

2.1 System requirements

Using with PicoScope for Windows

To ensure that your [PicoScope 6000E Series](#) PC Oscilloscope operates correctly, you must have a computer with at least the minimum system requirements to run one of the supported operating systems, as shown in the following table. The performance of the oscilloscope will be better with a more powerful PC, and will benefit from a multi-core processor.

Item	Specification
Operating system	All desktop versions of Windows with mainstream support. 32-bit and 64-bit versions.
Processor, memory, free disk space	As required by the operating system.
Ports	USB 2.0 or 3.0 port

Using with Linux

Drivers are available for various Linux distributions. [Instructions are available on our website](#).

Using with macOS

A software development kit (SDK) for macOS can be [downloaded from our website](#).

Using with custom applications

32-bit and 64-bit drivers are available for Windows. The 32-bit drivers will also run in 32-bit mode on 64-bit operating systems.

USB

The `ps6000a` driver offers [three different methods](#) of recording data, all of which support USB 2.0 and USB 3.0. A USB 3.0 port will offer the best performance especially in streaming mode or when retrieving large amounts of data from the oscilloscope.

2.2 Driver

Your application will communicate with a PicoScope 6000 library called `ps6000a.dll`, which is supplied in 32-bit and 64-bit versions. The driver exports the PicoScope 6000 [function definitions](#) in standard C format, but this does not limit you to programming in C. You can use the API with any programming language that supports standard C calls.

The API depends on another library, `picoipp.dll`, which is supplied in 32-bit and 64-bit versions, and on a low-level driver, `WinUsb.sys`. These drivers are installed by the SDK and configured when you plug the oscilloscope into each USB port for the first time. Your application does not call these drivers directly.

2.3 Voltage ranges

You can set a device input channel to any available voltage range with the [ps6000aSetChannelOn\(\)](#) function. Each sample is scaled to 16 bits. The minimum and maximum values returned to your application depend on the sampling resolution in use and can be queried by [ps6000aGetAdcLimits\(\)](#). This function replies with the following values:

Resolution	8 bits	10 bits	12 bits
Voltage	Value returned		
maximum	+32 512 (0x7F00)	+32 704 (0x7FC0)	+32 736 (0x7FE0)
zero	0	0	0
minimum	-32 512 (0x8100)	-32 704 (0x8040)	-32 736 (0x8020)

Example at 8-bit resolution

1. Call [ps6000aSetChannelOn\(\)](#) with range set to PICO_1V.
2. Apply a sine wave input of 500 mV amplitude to the oscilloscope.
3. Capture some data using the desired [sampling mode](#).
4. The data will be encoded as shown opposite.

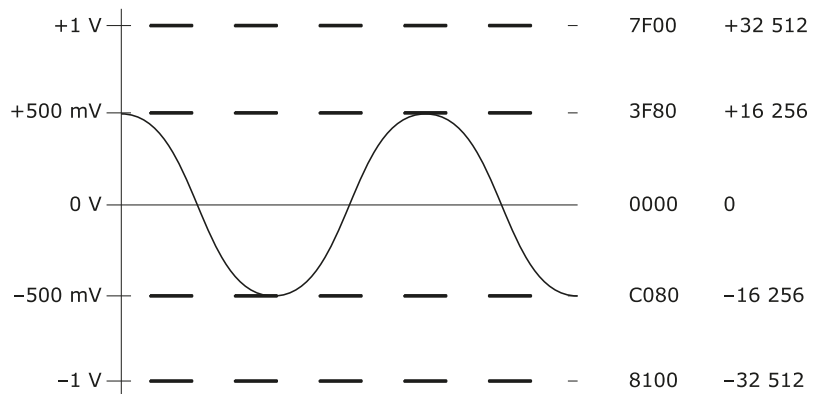

Digital inputs (with optional MSO pods)

See [ps6000aSetDigitalPort\(\)](#).

2.4 MSO digital data

Applicability

Any device with MSO pods attached. MSO pods are automatically recognized by the driver when connected.

A PicoScope MSO has two 8-bit digital ports—**Digital 1** and **Digital 2**—making a total of 16 digital channels.

Use the [ps6000aSetDataBuffer\(\)](#) and [ps6000aSetDataBuffers\(\)](#) functions to set up buffers into which the driver will write data from each port individually. For compatibility with the analog channels, each buffer is an array of 16-bit words. The 8-bit port data occupies the lower 8 bits of the word. The upper 8 bits of the word are undefined.

	Digital 2 buffer	Digital 1 buffer
Sample ₀	[XXXXXXXX,2D7...2D0] ₀	[XXXXXXXX,1D7...1D0] ₀
...
Sample _{n-1}	[XXXXXXXX,2D7...2D0] _{n-1}	[XXXXXXXX,1D7...1D0] _{n-1}

Retrieving stored digital data

The following C code snippet shows how to combine data from the two 8-bit ports into a single 16-bit word, and then how to extract individual bits from the 16-bit word.

```
// Mask Digital 2 values to get lower 8 bits
portValue = 0x00ff & appDigiBuffers[2][i];

// Shift by 8 bits to place in upper 8 bits of 16-bit word
portValue <<= 8;

// Mask Digital 1 values to get lower 8 bits,
// then OR with shifted Digital 2 bits to get 16-bit word
portValue |= 0x00ff & appDigiBuffers[0][i];

for (bit = 0; bit < 16; bit++)
{
    // Shift value 32768 (binary 1000 0000 0000 0000).
    // AND with value to get 1 or 0 for channel.
    // Order will be 2D7 to 2D0, then 1D7 to 1D0.

    bitValue = (0x8000 >> bit) & portValue? 1 : 0;
}
}
```

2.5 Triggering

PicoScope 6000E Series PC Oscilloscopes can either start collecting data immediately or be programmed to wait for a **trigger** event to occur. In both cases you need to use the trigger functions:

- [ps6000aSetTriggerChannelConditions\(\)](#)
- [ps6000aSetTriggerChannelDirections\(\)](#)
- [ps6000aSetTriggerChannelProperties\(\)](#)
- [ps6000aSetTriggerDelay\(\)](#) (optional)

These can be run collectively by calling [ps6000aSetSimpleTrigger\(\)](#), or singly.

A trigger event can occur when one of the input channels crosses a threshold voltage on either a rising or a falling edge. It is also possible to combine up to four inputs using the logic trigger function.

The driver supports these triggering methods:

- Simple edge
- Advanced edge
- Windowing
- Pulse width
- Logic
- Delay
- Drop-out
- Runt

The pulse width, delay and drop-out triggering methods additionally require the use of the pulse width qualifier functions:

- [ps6000aSetPulseWidthQualifierProperties\(\)](#)
- [ps6000aSetPulseWidthQualifierConditions\(\)](#)
- [ps6000aSetPulseWidthQualifierDirections\(\)](#)

2.6 Sampling modes

[PicoScope 6000E Series oscilloscopes](#) can run in various **sampling modes**.

- **Block mode.** In this mode, the scope stores data in its buffer memory and then transfers it to the PC. When the data has been collected it is possible to examine the data, with an optional downsampling factor. The data is lost when a new run is started in the same [segment](#), the settings are changed or the scope is powered down

The driver can return data asynchronously using a callback, which is a call to one of the functions in your own application. When you request data from the scope, you pass to the driver a pointer to your callback function. When the driver has written the data to your buffer, it makes a callback (calls your function) to signal that the data is ready. The callback function then signals to the application that the data is available.

Because the callback is called asynchronously from the rest of your application, in a separate thread, you must ensure that it does not corrupt any global variables while it runs.

If you do not wish to use a callback, you can poll the driver instead.

Rapid block mode. This is a variant of block mode that allows you to capture more than one waveform at a time with a minimum of delay between captures. You can use downsampling in this mode if you wish.

- **Streaming mode.** This mode enables long periods of data collection. In raw mode (no downsampling) it provides fast data transfer of unlimited amounts of data at up to 312 MB/s (3.2 ns per sample) in 8-bit mode with USB 3.0.

If downsampling is enabled, raw data can be sampled at up to 1.25 GS/s for a single channel in 8-bit mode. Downsampled data is returned while capturing is in progress, at up to 312 MB/s. The raw data can then be retrieved after the capture is complete. The number of raw samples is limited by the memory available on the device, the selected resolution and the number of channels enabled.

Triggering is supported in this mode.

Note: The oversampling feature of older PicoScope oscilloscopes has been replaced by [PICO_RATIO_MODE_AVERAGE](#).

2.6.1 Block mode

In **block mode**, the computer prompts a [PicoScope 6000E series](#) oscilloscope to collect a block of data into its internal memory. When the oscilloscope has collected the whole block, it signals that it is ready and then transfers the whole block to the computer's memory through the USB port.

- **Block size.** The maximum number of values depends upon the size of the oscilloscope's memory. The memory buffer is shared between the enabled channels, so if two channels are enabled, each receives half the memory. These features are handled transparently by the driver. The block size also depends on the number of memory segments in use (see [ps6000aMemorySegments\(\)](#)) and the sampling resolution.
- **Sampling rate.** A PicoScope 6000E Series oscilloscope can sample at a number of different rates according to the selected [timebase](#) and the combination of channels that are enabled. See the [PicoScope 6000E Series Data Sheet](#) for the specifications that apply to your scope model.

- **Setup time.** The driver normally performs a number of setup operations, which can take up to 50 milliseconds, before collecting each block of data. If you need to collect data with the minimum time interval between blocks, use [rapid block mode](#) and avoid calling setup functions between calls to [ps6000aRunBlock\(\)](#), [ps6000aStop\(\)](#) and [ps6000aGetValues\(\)](#).
- **Downsampling.** When the data has been collected, you can set an optional [downsampling](#) factor and examine the data. Downsampling is a process that reduces the amount of data by combining adjacent samples. It is useful for zooming in and out of the data without having to repeatedly transfer the entire contents of the scope's buffer to the PC.
- **Memory segmentation.** The scope's internal memory can be divided into segments so that you can capture several waveforms in succession. Configure this using [ps6000aMemorySegments\(\)](#) or [ps6000aMemorySegmentsBySamples\(\)](#).
- **Data retention.** The data is lost when a new run is started in the same segment, the settings are changed, or the scope is powered down.

See [Using block mode](#) for programming details.

2.6.1.1 Using block mode

This is the general procedure for reading and displaying data in [block mode](#) using a single [memory segment](#):

1. Open the oscilloscope using [ps6000aOpenUnit\(\)](#).
2. Select channel ranges and AC/DC/50 Ω coupling using [ps6000aSetChannelOn\(\)](#) and [ps6000aSetChannelOff\(\)](#).
3. Using [ps6000aGetTimebase\(\)](#), select timebases until the required nanoseconds per sample is located.
4. Use the trigger setup functions [ps6000aSetTriggerChannelConditions\(\)](#), [ps6000aSetTriggerChannelDirections\(\)](#) and [ps6000aSetTriggerChannelProperties\(\)](#) to set up the trigger if required.
5. Start the oscilloscope running using [ps6000aRunBlock\(\)](#).
6. Wait until the oscilloscope is ready using the [ps6000aBlockReady\(\)](#) callback (or poll using [ps6000aIsReady\(\)](#)).
7. Use [ps6000aSetDataBuffer\(\)](#) to tell the driver where your memory buffer is. For greater efficiency with multiple captures, you can do this outside the loop after step 4.
8. Transfer the block of data from the oscilloscope using [ps6000aGetValues\(\)](#).
9. Display the data.
10. Repeat steps 5 to 9.
11. Stop the oscilloscope using [ps6000aStop\(\)](#).
12. Request new views of stored data using different downsampling parameters: see [Retrieving stored data](#).
13. Close the device using [ps6000aCloseUnit\(\)](#).

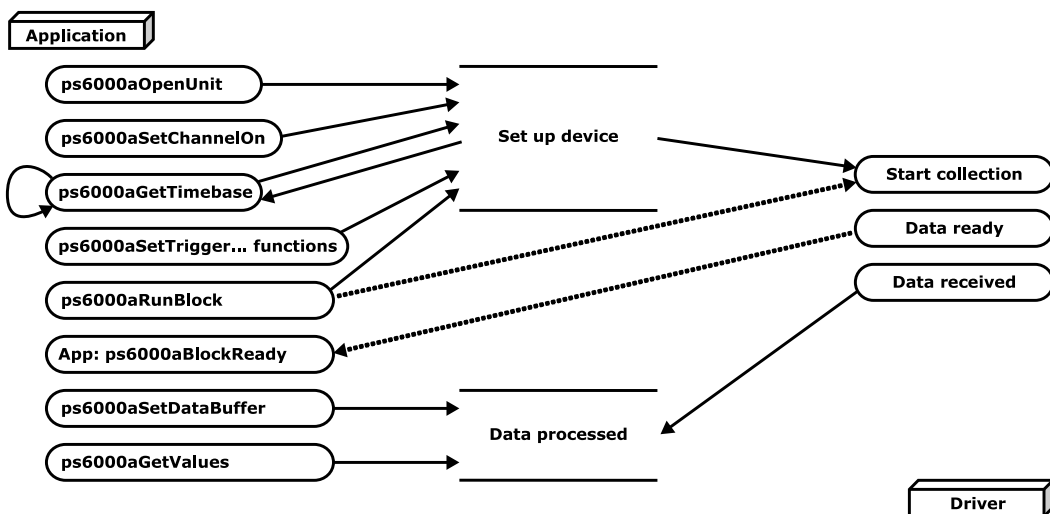

2.6.1.2 Asynchronous calls in block mode

[ps6000aGetValues\(\)](#) may take a long time to complete if a large amount of data is being collected. To avoid hanging the calling thread, it is possible to call [ps6000aGetValuesAsync\(\)](#) instead. This immediately returns control to the calling thread, which then has the option of waiting for the data or calling [ps6000aStop\(\)](#) to abort the operation.

2.6.2 Rapid block mode

In normal [block mode](#), the PicoScope 6000E Series scopes collect one waveform at a time. You start the device running, wait until all samples are collected by the device, and then download the data to the PC or start another run. There is a time overhead of tens of milliseconds associated with starting a run, causing a gap between waveforms. When you collect data from the device, there is another minimum time overhead which is most noticeable when using a small number of samples.

Rapid block mode allows you to sample several waveforms at a time with the minimum time between waveforms. It reduces the gap from milliseconds to less than 1 microsecond.

See [Using rapid block mode](#) for details.

2.6.2.1 Using rapid block mode

You can use [rapid block mode](#) with or without aggregation. With aggregation, you need to set up two buffers for each channel, to receive the minimum and maximum values.

Without aggregation

1. Open the oscilloscope using [ps6000aOpenUnit\(\)](#).
2. Select channel ranges and AC/DC coupling using [ps6000aSetChannelOn\(\)](#) and [ps6000aSetChannelOff\(\)](#).
3. Set the number of memory segments equal to or greater than the number of captures required using [ps6000aMemorySegments\(\)](#). Use [ps6000aSetNoOfCaptures\(\)](#) before each run to specify the number of waveforms to capture.
4. Using [ps6000aGetTimebase\(\)](#), select timebases until the required nanoseconds per sample is located.
5. Use the trigger setup functions [ps6000aSetTriggerChannelConditions\(\)](#), [ps6000aSetTriggerChannelDirections\(\)](#) and [ps6000aSetTriggerChannelProperties\(\)](#) to set up the trigger if required.
6. Start the oscilloscope running using [ps6000aRunBlock\(\)](#).
7. Wait until the oscilloscope is ready using the [ps6000aBlockReady\(\)](#) callback.
8. Use [ps6000aSetDataBuffer\(\)](#) to tell the driver where your memory buffers are. Call the function once for each channel/[segment](#) combination for which you require data. For greater efficiency with multiple captures, you could do this outside the loop after step 5.
9. Transfer the blocks of data from the oscilloscope using [ps6000aGetValuesBulk\(\)](#).
10. Retrieve the time offset for each data segment using [ps6000aGetValuesTriggerTimeOffsetBulk\(\)](#).
11. Display the data.
12. Repeat steps 6 to 11 if necessary.
13. Stop the oscilloscope using [ps6000aStop\(\)](#).
14. Close the device using [ps6000aCloseUnit\(\)](#).

With aggregation

To use rapid block mode with aggregation, follow steps 1 to 7 above and then proceed as follows:

- 8a. Call [ps6000aSetDataBuffers\(\)](#) to set up one pair of buffers for every waveform segment required.
- 9a. Call [ps6000aGetValuesBulk\(\)](#) for each pair of buffers.
- 10a. Retrieve the time offset for each data segment using [ps6000aGetValuesTriggerTimeOffsetBulk\(\)](#).

Continue from step 11 above.

2.6.2.2 Rapid block mode example 1: no aggregation

```
#define MAX_WAVEFORMS 100
#define MAX_SAMPLES 1000
```

Set up the device up as usual.

- Open the device
- Channels
- Trigger
- Number of memory segments (this should be equal or more than the no of captures required)

```
// set the number of waveforms to MAX_WAVEFORMS
ps6000aSetNoOfCaptures(handle, MAX_WAVEFORMS);
```

```
pParameter = false;
ps6000aRunBlock
(
    handle,
    0,           // noOfPreTriggerSamples
    10000,      // noOfPostTriggerSamples
    1,          // timebase to be used
    &timeIndisposedMs,
    0,          // segment index
    lpReady,
    &pParameter
);
```

Comment: these variables have been set as an example and can be any valid value. `pParameter` will be set true by your callback function `lpReady`.

```
while (!pParameter) Sleep (0);
```

```
PICO_ACTION action = PICO_CLEAR_ALL | PICO_ADD;
int32_t first_segment_to_read = 10;
```

```
for (int32_t i = 0; i < 10; i++)
{
    for (int32_t c = PICO_CHANNEL_A; c <= PICO_CHANNEL_D; c++)
    {
        ps6000aSetDataBuffer
        (
            handle,
            c,
            buffer[c][i],
            MAX_SAMPLES,
            PICO_INT16_T,
            first_segment_to_read + i,
            PICO_RATIO_MODE_RAW,
            action
        );
        action = PICO_ADD;
    }
}
```

```
}
```

Comments: buffer has been created as a two-dimensional array of pointers to `int16_t`, which will contain 1000 samples as defined by `MAX_SAMPLES`. Only 10 buffers are set, but it is possible to set up to the number of captures you have requested.

[ps6000aGetValuesBulk](#)

```
(
  handle,
  0, // startIndex
  &noOfSamples, // set to MAX_SAMPLES on entering the function
  10, // fromSegmentIndex
  19, // toSegmentIndex
  1, // downsampling ratio
  PICO_RATIO_MODE_RAW, // downsampling ratio mode
  overflow // indices 0 to 9 will be populated (index always
    starts from 0)
)
```

Comments: the number of samples could be up to `noOfPreTriggerSamples + noOfPostTriggerSamples`, the values set in [ps6000aRunBlock\(\)](#). The samples are returned starting from the sample index. This function does not support aggregation. The above segments start at 10 and finish at 19 inclusive. It is possible for `fromSegmentIndex` to wrap around to `toSegmentIndex`, for example by setting `fromSegmentIndex` to 98 and `toSegmentIndex` to 7.

[ps6000aGetValuesTriggerTimeOffsetBulk](#)

```
(
  handle,
  times,
  timeUnits,
  10,
  19
)
```

Comments: the above segments start at 10 and finish at 19 inclusive. It is possible for the `fromSegmentIndex` to wrap around to the `toSegmentIndex`, for example if `fromSegmentIndex` is set to 98 and `toSegmentIndex` to 7.

2.6.2.3 Rapid block mode example 2: using aggregation

```
#define MAX_WAVEFORMS 100
#define MAX_SAMPLES 1000
```

Set up the device up as usual.

- Open the device
- Channels
- Trigger
- Number of memory segments (this should be equal or more than the number of captures required)

```
// set the number of waveforms to MAX_WAVEFORMS
ps6000aSetNoOfCaptures(handle, MAX_WAVEFORMS);
```

```
pParameter = false;
ps6000aRunBlock
(
    handle,
    0,           // noOfPreTriggerSamples,
    1000000,    // noOfPostTriggerSamples,
    1,         // timebase to be used,
    &timeIndisposedMs,
    0,         // segmentIndex
    lpReady,
    &pParameter
);
```

Comments: the set-up for running the device is exactly the same whether or not aggregation will be used when you retrieve the samples.

```
PICO_ACTION action = PICO_CLEAR_ALL | PICO_ADD;

for (int32_t c = PICO_CHANNEL_A; c <= PICO_CHANNEL_D; c++)
{
    ps6000aSetDataBuffers
    (
        handle,
        c,
        bufferMax[c],
        bufferMin[c]
        MAX_SAMPLES,
        PICO_INT16_T,
        0,
        PICO_RATIO_MODE_AGGREGATE,
        action
    );
    action = PICO_ADD;
}
```

Comments: since only one waveform will be retrieved at a time, you only need to set up one pair of buffers; one for the maximum samples and one for the minimum samples. Again, the buffer sizes are 1000 samples.

```
for (int32_t segment = 10; segment < 20; segment++)
```

```
{
  ps6000aGetValues
  (
    handle,
    0,
    &noOfSamples,          // set to MAX_SAMPLES on entering
    1000,
    &downSampleRatioMode, // set to RATIO_MODE_AGGREGATE
    index,
    overflow
  );

  ps6000aGetTriggerTimeOffset
  (
    handle,
    &time,
    &timeUnits,
    index
  )
}
```

Comments: each waveform is retrieved one at a time from the driver with an aggregation of 1000.

2.6.3 Streaming mode

Streaming mode can capture data without the gaps that occur between blocks when using [block mode](#). This makes it suitable for **high-speed data acquisition**, allowing you to capture long data sets limited only by the computer's memory. (At the highest sampling rates, the size of the device's capture buffer may limit the capture size.)

The device can return either raw or [downsampled](#) data to your application while streaming is in progress. When downsampled data is returned, the raw samples remain stored on the device.

- **Downsampling.** The driver can return either raw or downsampled data. You should set up the number of buffers needed to accept the requested data. Aggregation requires two buffers, one for the minimum values and one for the maximum values. Other downsampling modes require only a single buffer.

See [Using streaming mode](#) for programming details.

2.6.3.1 Using streaming mode

This is the general procedure for reading and displaying data in [streaming mode](#) using a single [memory segment](#):

1. Open the oscilloscope using [ps6000aOpenUnit\(\)](#).
2. Select channels, ranges and AC/DC/50 Ω coupling using [ps6000aSetChannelOn\(\)](#) and [ps6000aSetChannelOff\(\)](#).
3. Use the trigger setup functions [ps6000aSetTriggerChannelConditions\(\)](#), [ps6000aSetTriggerChannelDirections\(\)](#) and [ps6000aSetTriggerChannelProperties\(\)](#) to set up the trigger if required.
4. Call [ps6000aSetDataBuffer\(\)](#) to tell the driver where your data buffer is.
5. Set up aggregation and start the oscilloscope running using [ps6000aRunStreaming\(\)](#).
6. Call [ps6000aGetStreamingLatestValues\(\)](#) to get data. If the function runs out of buffer space, return to step 4.
7. Process data returned to your application's function. This example is using autoStop, so after the driver has received all the data points requested by the application, it stops the device streaming.
8. Call [ps6000aStop\(\)](#), even if autoStop is enabled.
9. Request new views of stored data using different downsampling parameters: see [Retrieving stored data](#).
10. Close the device using [ps6000aCloseUnit\(\)](#).

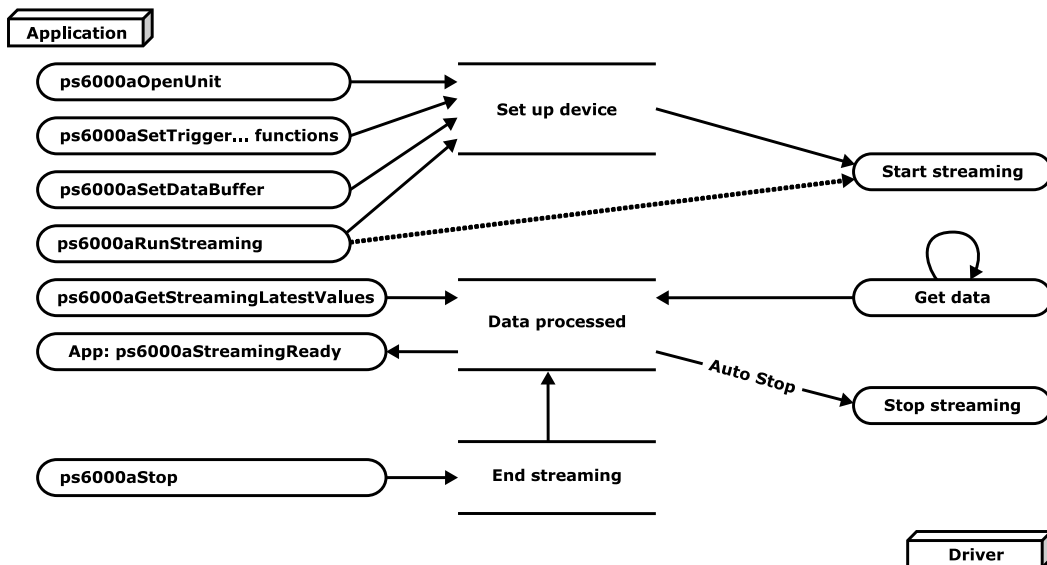

2.6.4 Retrieving stored data

You can retrieve data from the `ps6000a` driver with a different [downsampling](#) factor when `ps6000aRunBlock()` or `ps6000aRunStreaming()` has already been called and has successfully captured all the data. Use `ps6000aGetValuesAsync()`.

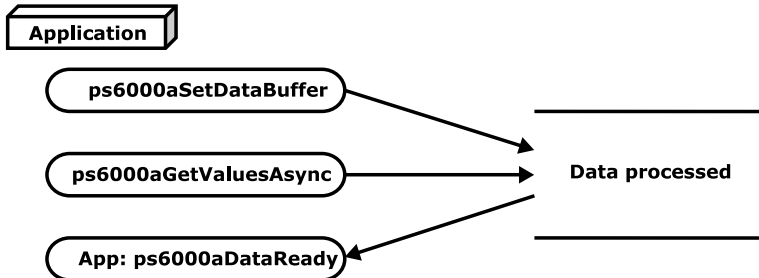

2.7 Timebases

The API allows you to select any of 2^{32} different timebases based on a maximum sampling rate of 5 GHz. The timebases allow slow enough sampling in block mode to overlap the streaming sample intervals, so that you can make a smooth transition between [block mode](#) and [streaming mode](#).

For the PicoScope 6000E Series except the PicoScope 6428E-D:

timebase	sample interval formula	sample interval examples
0 to 4	$2^{\text{timebase}} / 5\,000\,000\,000$	0 => 200 ps 1 => 400 ps 2 => 800 ps 3 => 1.6 ns 4 => 3.2 ns
5 to $2^{32}-1$	$(\text{timebase}-4) / 156\,250\,000$	5 => 6.4 ns ... $2^{32}-1$ => ~ 27.49 s

For the PicoScope 6428E-D:

timebase	sample interval formula	sample interval examples
0 to 5	$2^{\text{timebase}} / 10\,000\,000\,000$	0 => 100 ps 1 => 200 ps 2 => 400 ps 3 => 800 ps 4 => 1.6 ns 5 => 3.2 ns
6 to $2^{32}-1$	$(\text{timebase}-5) / 156\,250\,000$	6 => 6.4 ns ... $2^{32}-1$ => ~ 27.49 s

Applicability	Calls to ps6000aGetTimebase()
----------------------	---

Notes

1. The maximum possible sampling rate may depend on the number of enabled channels and on the sampling mode. Please refer to the data sheet for details.
2. In [streaming mode](#), the speed of the USB port may affect the rate of data transfer.

2.8 Combining several oscilloscopes

It is possible to collect data using up to 64 PicoScope 6000E Series oscilloscopes at the same time, depending on the capabilities of the PC. Each oscilloscope must be connected to a separate USB port. The [ps6000aOpenUnit\(\)](#) function returns a handle to an oscilloscope. All the other functions require this handle for oscilloscope identification. For example, to collect data from two oscilloscopes at the same time:

```
CALLBACK ps6000aBlockReady(...)
// define callback function specific to application

handle1 = ps6000aOpenUnit()
handle2 = ps6000aOpenUnit()

ps6000aSetChannelOn(handle1)
// set up unit 1
ps6000aRunBlock(handle1)

ps6000aSetChannelOn(handle2)
// set up unit 2
ps6000aRunBlock(handle2)

// data will be stored in buffers
// and application will be notified using callback

ready = FALSE
while not ready
    ready = handle1_ready
    ready &= handle2_ready
```

Note: an external clock may be fed into the **10 MHz** clock reference input or a trigger into the **Aux Trig** input to provide some degree of synchronization between multiple oscilloscopes.

2.9 Handling intelligent probe interactions

The PicoScope 6000E Series has an intelligent probe interface, which supplies power to the probe as well as allowing the scope to configure and interrogate the probe. Your application can choose to be alerted whenever a probe is connected or disconnected, or when its status changes.

Probe interactions use a callback mechanism, available in C and similar languages.

Applicability	All models
Note	In addition to <code>ps6000aApi.h</code> , you must also include <code>PicoDeviceEnums.h</code> . This file contains definitions of enumerated types that describe the intelligent probes.

Procedure

1. Define your own function to receive probe interaction callbacks.
2. Call `ps6000aOpenUnit()` to obtain a device handle.
3. Call `ps6000aSetProbeInteractionCallback()` to register your probe interaction callback function.
4. Capture data using the desired sampling mode. See [Sampling modes](#) for details.
5. Call `ps6000aCloseUnit()` to release the device handle. This makes the scope device available to other applications.

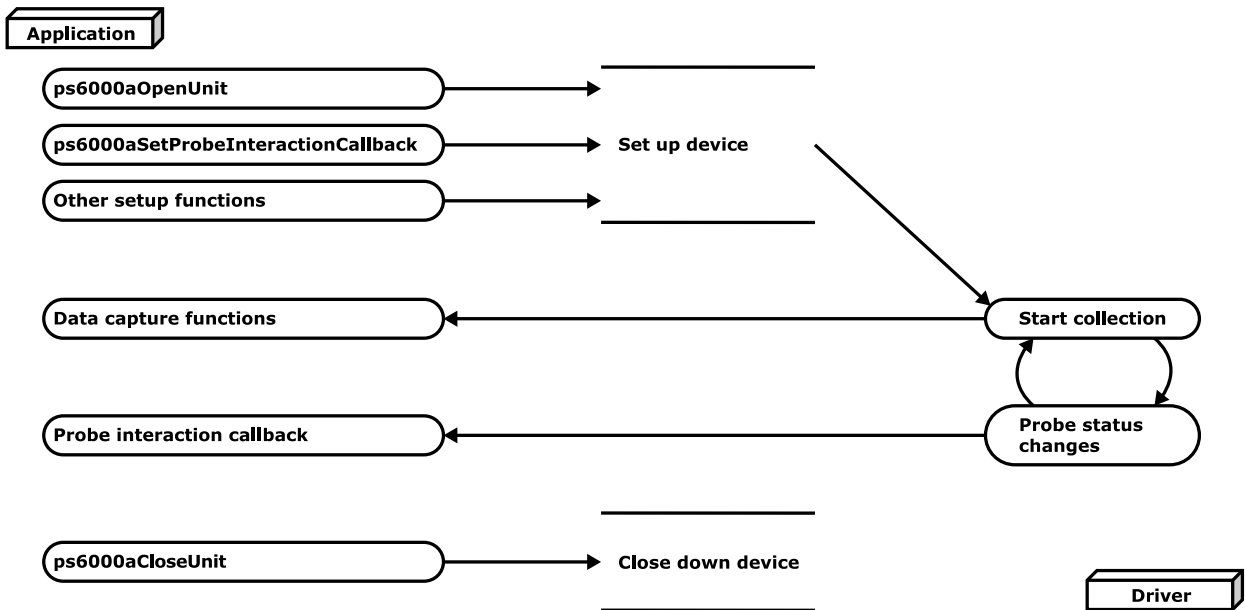

3 API functions

The PicoScope 6000E Series API exports the following functions for you to use in your own applications for Microsoft Windows. Similar APIs are available for other platforms: see www.picotech.com > [Downloads](#) for details. All functions are C functions using the standard call naming convention (`__stdcall`). They are all exported with both decorated and undecorated names.

3.1 ps6000aChannelCombinationsStateless - get possible channel combinations

[PICO_STATUS](#) ps6000aChannelCombinationsStateless

```
(
    int16_t          handle,
    PICO_CHANNEL_FLAGS * channelFlagsCombinations,
    uint32_t         * nChannelCombinations,
    PICO_DEVICE_RESOLUTION resolution,
    uint32_t         timebase
)
```

This function returns a list of the possible channel combinations given a proposed configuration (resolution and timebase) of the oscilloscope. It does not change the configuration of the oscilloscope.

Applicability

All modes

Arguments

`handle`, the device identifier returned by [ps6000aOpenUnit\(\)](#).

* `channelFlagsCombinations`, on exit, a list of possible channel combinations. See `PicoDeviceEnums.h`.

* `nChannelCombinations`, on exit, the length of the `channelFlagsCombinations` list.

`resolution`, the proposed vertical resolution of the oscilloscope.

`timebase`, the proposed timebase number.

Returns

PICO_OK

PICO_INVALID_HANDLE

PICO_NULL_PARAMETER

PICO_INVALID_PARAMETER

3.2 ps6000aCheckForUpdate - is firmware update available?

```
PICO_STATUS ps6000aCheckForUpdate  
(  
    int16_t          handle,  
    PICO_FIRMWARE_INFO * firmwareInfos,  
    int16_t          * nFirmwareInfos,  
    uint16_t         * updatesRequired  
)
```

This function checks whether a firmware update for the device is available.

Applicability

All modes

Arguments

`handle`, the device identifier returned by [ps6000aOpenUnit\(\)](#).

`firmwareInfos`, a pointer to a buffer of `PICO_FIRMWARE_INFO` structs which, on exit, will be populated with detailed information about the available updates. Information about firmware which is already up to date will also be provided. You may pass `NULL` if you do not require the detailed information.

`nFirmwareInfos`, on entry, a pointer to a value which is the length of the `firmwareInfos` buffer, if `firmwareInfos` is not `NULL`. On exit, the number of populated entries in `firmwareInfos` (or the available number of `PICO_FIRMWARE_INFOS` if `firmwareInfos` is `NULL`). May be `NULL` if the caller does not need detailed firmware information (in which case `firmwareInfos` must also be `NULL`).

* `updatesRequired`, on entry, a pointer to a flag which will be set by the function to indicate if updates are required. On exit, 1 if updates are required and 0 otherwise.

Returns

`PICO_OK`
`PICO_HANDLE_INVALID`
`PICO_USER_CALLBACK`
`PICO_DRIVER_FUNCTION`

3.3 ps6000aCloseUnit - close a scope device

```
PICO\_STATUS ps6000aCloseUnit  
(  
    int16_t    handle  
)
```

This function shuts down a PicoScope 6000E Series oscilloscope.

Applicability

All modes

Arguments

handle, the device identifier returned by [ps6000aOpenUnit\(\)](#).

Returns

PICO_OK
PICO_HANDLE_INVALID
PICO_USER_CALLBACK
PICO_DRIVER_FUNCTION

3.4 ps6000aEnumerateUnits - get a list of unopened units

```
PICO_STATUS ps6000aEnumerateUnits
(
    int16_t    * count,
    int8_t     * serials,
    int16_t    * serialLth
)
```

This function counts the number of PicoScope 6000 (A API) units connected to the computer, and returns a list of serial numbers and other optional information as a string. Note that this function can only detect devices that are not yet being controlled by an application. To query opened devices, use [ps6000aGetUnitInfo\(\)](#).

Applicability

All modes

Arguments

* `count`, on exit, the number of PicoScope 6000 (A API) units found.

* `serials`, if an empty string on entry, `serials` is populated on exit with a list of serial numbers separated by commas and terminated by a final null. Example:

```
AQ005/139, VDR61/356, ZOR14/107
```

On entry, `serials` can optionally contain the following parameter(s) to request information:

```
-v : model number
-c : calibration date
-h : hardware version
-u : USB version
-f : firmware version
```

Example (any separator character can be used):

```
-v:-c:-h:-u:-f
```

On exit, with all the above parameters specified, each serial number has the requested information appended in the following format:

```
AQ005/139[6425E,01Jan21,769,2.0,1.7.16.0]
```

`serials` can be NULL if device information or serial numbers are not required.

* `serialLth`, on entry, the length of the `int8_t` buffer pointed to by `serials`; on exit, the length of the string written to `serials`

Returns

```
PICO_OK
PICO_BUSY
PICO_NULL_PARAMETER
PICO_FW_FAIL
PICO_CONFIG_FAIL
PICO_MEMORY_FAIL
PICO_ANALOG_BOARD
PICO_CONFIG_FAIL_AWG
PICO_INITIALISE_FPGA
```

3.5 ps6000aFlashLed - flash the front-panel LED

```
PICO\_STATUS ps6000aFlashLed  
(  
    int16_t    handle,  
    int16_t    start  
)
```

This function flashes the status/trigger LED on the front of the scope without blocking the calling thread. Calls to [ps6000aRunStreaming\(\)](#) and [ps6000aRunBlock\(\)](#) cancel any flashing started by this function. It is not possible to set the LED to be constantly illuminated, as this state is used to indicate that the scope has not been initialized.

Applicability

All modes

Arguments

`handle`, the device identifier returned by [ps6000aOpenUnit\(\)](#).

`start`, the action required:

- < 0 : flash the LED indefinitely.
- 0 : stop the LED flashing.
- > 0 : flash the LED `start` times. If the LED is already flashing on entry to this function, the flash count will be reset to `start`.

Returns

PICO_OK
PICO_HANDLE_INVALID
PICO_BUSY
PICO_DRIVER_FUNCTION
PICO_NOT_RESPONDING

3.6 ps6000aGetAccessoryInfo - get information about a connected accessory

```
PICO\_STATUS ps6000aGetAccessoryInfo  
(  
    int16_t        handle,  
    PICO_CHANNEL   channel,  
    int8_t         * string,  
    int16_t        stringLength,  
    int16_t        * requiredSize,  
    PICO_INFO      info  
)
```

This function gets information about an accessory connected to the specified channel on the oscilloscope.

Applicability

All modes

Arguments

`handle`, the device identifier returned by [ps6000aOpenUnit\(\)](#).

`channel`, the oscilloscope channel to which the accessory is connected.

`string`, on exit: a buffer to which the information will be written.

`stringLength`, the length of the `string` buffer.

`requiredSize`, on exit: the length of the information before being stored in the `string` buffer; if it's longer than `stringLength`, it will be truncated to fit the buffer. If truncation occurs and you need the full information, you can call the function again with the buffer extended to `requiredSize`.

`info`, the type of information you require. See [ps6000aGetUnitInfo\(\)](#) for a list of `info` types.

Returns

PICO_OK

PICO_INVALID_HANDLE

PICO_DRIVER_FUNCTION

PICO_NULL_PARAMETER

PICO_INTERNAL_ERROR

PICO_FIRMWARE_UPDATE_REQUIRED_TO_USE_DEVICE_WITH_THIS_DRIVER

3.7 ps6000aGetAdcLimits - get min and max sample values

```
PICO_STATUS ps6000aGetAdcLimits  
(  
    int16_t          handle,  
    PICO_DEVICE_RESOLUTION resolution,  
    int16_t          * minValue,  
    int16_t          * maxValue  
)
```

This function gets the maximum and minimum sample values that the ADC can produce at a given resolution.

Applicability

All modes

Arguments

`handle`, the device identifier returned by [ps6000aOpenUnit\(\)](#).

`resolution`, the vertical resolution about which you require information.

* `minValue`, the minimum sample value.

* `maxValue`, the maximum sample value.

Returns

PICO_OK

PICO_INVALID_HANDLE

PICO_DRIVER_FUNCTION

PICO_NULL_PARAMETER (if both `maxValue` and `minValue` are NULL)

3.8 ps6000aGetAnalogueOffsetLimits - get analog offset information

```
PICO_STATUS ps6000aGetAnalogueOffsetLimits  
(  
    int16_t                handle,  
    PICO_CONNECT_PROBE_RANGE range,  
    PICO_COUPLING          coupling,  
    double                 * maximumVoltage,  
    double                 * minimumVoltage  
)
```

This function is used to get the maximum and minimum allowable analog offset for a specific voltage range.

Applicability

All modes

Arguments

`handle`, the device identifier returned by [ps6000aOpenUnit\(\)](#).

`range`, the voltage range for which minimum and maximum voltages are required

`coupling`, the type of AC/DC/50 Ω coupling used

* `maximumVoltage`, on output, the maximum analog offset voltage allowed for the range. Set to NULL if not required.

* `minimumVoltage`, on output, the minimum analog offset voltage allowed for the range. Set to NULL if not required.

Returns

PICO_OK

PICO_INVALID_HANDLE

PICO_DRIVER_FUNCTION

PICO_INVALID_VOLTAGE_RANGE

PICO_NULL_PARAMETER (if both `maximumVoltage` and `minimumVoltage` are NULL)

PICO_INVALID_COUPLING

3.9 ps6000aGetDeviceResolution – retrieve the device resolution

```
PICO\_STATUS ps6000aGetDeviceResolution  
(  
    int16_t          handle,  
    PICO\_DEVICE\_RESOLUTION * resolution  
)
```

This function retrieves the vertical resolution of the oscilloscope.

Applicability

All modes

Arguments

handle, the device identifier returned by [ps6000aOpenUnit\(\)](#).

* resolution, on exit, the resolution of the device.

Returns

PICO_OK or other code from `PicoStatus.h`

3.10 ps6000aGetMaximumAvailableMemory - depending on hardware resolution

```
PICO_STATUS ps6000aGetMaximumAvailableMemory  
(  
    int16_t          handle,  
    uint64_t        * nMaxSamples,  
    PICO_DEVICE_RESOLUTION resolution  
)
```

This function returns the maximum number of samples that can be stored at a given hardware resolution.

Applicability

All modes

Arguments

`handle`, the device identifier returned by [ps6000aOpenUnit\(\)](#).

* `nMaxSamples`, on exit, the number of samples.

`resolution`, the resolution in bits.

Returns

PICO_OK
PICO_INVALID_HANDLE
PICO_NO_SAMPLES_AVAILABLE
PICO_NULL_PARAMETER
PICO_INVALID_PARAMETER
PICO_SEGMENT_OUT_OF_RANGE
PICO_TOO_MANY_SAMPLES

3.11 ps6000aGetMinimumTimebaseStateless - find fastest available timebase

```
PICO_STATUS ps6000aGetMinimumTimebaseStateless  
(  
    int16_t          handle,  
    PICO_CHANNEL_FLAGS enabledChannelFlags,  
    uint32_t         * timebase,  
    double           * timeInterval,  
    PICO_DEVICE_RESOLUTION resolution  
)
```

This function returns the shortest timebase that could be selected with a proposed configuration of the oscilloscope. It does not set the oscilloscope to the proposed configuration.

Applicability

All modes

Arguments

`handle`, the device identifier returned by [ps6000aOpenUnit\(\)](#).

`enabledChannelFlags`, a bit field indicating which channels are enabled in the proposed configuration. Channel A is bit 0 and so on.

* `timebase`, on exit, the number of the shortest timebase possible with the proposed configuration.

* `timeInterval`, on exit, the sample period in seconds corresponding to `.timebase`.

`resolution`, the vertical resolution in the proposed configuration.

Returns

PICO_OK
PICO_INVALID_HANDLE
PICO_NO_SAMPLES_AVAILABLE
PICO_NULL_PARAMETER
PICO_INVALID_PARAMETER
PICO_SEGMENT_OUT_OF_RANGE
PICO_TOO_MANY_SAMPLES

3.12 ps6000aGetNoOfCaptures - query how many captures made

```
PICO_STATUS ps6000aGetNoOfCaptures  
(  
    int16_t    handle,  
    uint64_t * nCaptures  
)
```

This function returns the number of captures collected in one run of [rapid block mode](#). You can call this function during device capture, after collection has completed or after interrupting waveform collection by calling [ps6000aStop\(\)](#).

The returned value (nCaptures) can then be used to iterate through the number of segments using [ps6000aGetValues\(\)](#), or in a single call to [ps6000aGetValuesBulk\(\)](#) where it is used to calculate the toSegmentIndex parameter.

Applicability

All modes

Arguments

handle, the device identifier returned by [ps6000aOpenUnit\(\)](#).

nCaptures, on output, the number of available captures that has been collected from calling [ps6000aRunBlock\(\)](#).

Returns

PICO_OK
PICO_INVALID_HANDLE
PICO_NO_SAMPLES_AVAILABLE
PICO_NULL_PARAMETER
PICO_INVALID_PARAMETER
PICO_SEGMENT_OUT_OF_RANGE
PICO_TOO_MANY_SAMPLES

3.13 ps6000aGetNoOfProcessedCaptures - query how many captures processed

```
PICO_STATUS ps6000aGetNoOfProcessedCaptures
(
    int16_t    handle,
    uint64_t  * nProcessedCaptures
)
```

This function gets the number of captures collected and processed in one run of [rapid block mode](#). It enables your application to start processing captured data while the driver is still transferring later captures from the device to the computer.

The function returns the number of captures the driver has processed since you called [ps6000aRunBlock\(\)](#). It is for use in rapid block mode, alongside the [ps6000aGetValuesOverlapped\(\)](#) function, when the driver is set to transfer data from the device automatically as soon as the [ps6000aRunBlock\(\)](#) function is called. You can call [ps6000aGetNoOfProcessedCaptures\(\)](#) during device capture, after collection has completed or after interrupting waveform collection by calling [ps6000aStop\(\)](#).

The returned value (`nProcessedCaptures`) can then be used to iterate through the number of segments using [ps6000aGetValues\(\)](#), or in a single call to [ps6000aGetValuesBulk\(\)](#), where it is used to calculate the `toSegmentIndex` parameter.

When capture is stopped

If `nProcessedCaptures = 0`, you will also need to call [ps6000aGetNoOfCaptures\(\)](#), in order to determine how many waveform segments were captured, before calling [ps6000aGetValues\(\)](#) or [ps6000aGetValuesBulk\(\)](#).

Applicability

[Rapid block mode](#)

Arguments

`handle`, the device identifier returned by [ps6000aOpenUnit\(\)](#).

* `nProcessedCaptures`, on exit, the number of waveforms captured and processed.

Returns

PICO_OK
PICO_INVALID_HANDLE
PICO_INVALID_PARAMETER

3.14 ps6000aGetStreamingLatestValues - read streaming data

```
PICO_STATUS ps6000aGetStreamingLatestValues
(
    int16_t                handle,
    PICO_STREAMING_DATA_INFO * streamingDataInfo,
    uint64_t              nStreamingDataInfos,
    PICO_STREAMING_DATA_TRIGGER_INFO * triggerInfo
)
```

This function populates the `streamingDataInfo` structure with a description of the samples available and the `triggerInfo` structure to indicate that a trigger has occurred and at what location.

Applicability

[Streaming mode](#) only

Arguments

`handle`, the device identifier returned by [ps6000aOpenUnit\(\)](#).

* `streamingDataInfo`, a list of structures. See [PICO_STREAMING_DATA_INFO](#).

`nStreamingDataInfos`, the number of structures in the `streamingDataInfo` list.

* `triggerInfo`, a list of structures containing trigger information. See [PICO_STREAMING_DATA_TRIGGER_INFO](#).

Returns

PICO_OK
 PICO_WAITING_FOR_DATA_BUFFERS - indicates that you need to call [ps6000aSetDataBuffer\(\)](#) again

3.14.1 PICO_STREAMING_DATA_INFO

A list of structures of this type is passed to [ps6000aGetStreamingLatestValues\(\)](#) in the `streamingDataInfo` argument to specify parameters for streaming mode data capture. It is defined as follows:

```
typedef struct tPicoStreamingDataInfo
{
    PICO_CHANNEL      channel_;
    PICO_RATIO_MODE   mode_;
    PICO_DATA_TYPE     type_;
    int32_t           noOfSamples_;
    uint64_t          bufferIndex_;
    int32_t           startIndex_;
    int16_t           overflow_;
} PICO_STREAMING_DATA_INFO;
```

The structure is byte-aligned. In C++, for example, you should specify this using the `#pragma pack()` instruction.

Elements

`channel_`, the oscilloscope channel that the parameters apply to.

`mode_`, the downsampling mode to use.

`type_`, the data type to use for the sample data.

`noOfSamples_`, the number of samples made available by the driver.

`bufferIndex_`, an index to the starting sample within the specified waveform buffer.

`startIndex_`, an index to the waveform buffer within the capture buffer.

`overflow_`, a flag indicating whether a sample value overflowed (1) or not (0).

3.14.2 PICO_STREAMING_DATA_TRIGGER_INFO

A structure of this type is returned by [ps6000aGetStreamingLatestValues\(\)](#) in the `triggerInfo` argument to return information about trigger events.

```
typedef struct tPicoStreamingDataTriggerInfo
{
    uint64_t  triggerAt_;
    int16_t   triggered_;
    int16_t   autoStop_;
} PICO_STREAMING_DATA_TRIGGER_INFO;
```

The structure is byte-aligned. In C++, for example, you should specify this using the `#pragma pack()` instruction.

Elements

`triggerAt_`, an index to the sample on which the trigger occurred.

`triggered_`, a flag indicating whether a trigger occurred (1) or did not occur (0).

`autoStop_`, a flag indicating whether the oscilloscope was in autoStop mode (1) or not (0).

3.15 ps6000aGetTimebase - get available timebases

```
PICO_STATUS ps6000aGetTimebase
(
    int16_t      handle,
    uint32_t     timebase,
    uint64_t     noSamples,
    double       * timeIntervalNanoseconds,
    uint64_t     * maxSamples
    uint64_t     segmentIndex
)
```

This function calculates the sampling rate and maximum number of samples for a given [timebase](#) under the specified conditions. The result will depend on the number of channels enabled by the last call to [ps6000aSetChannelOn\(\)](#) or [ps6000aSetChannelOff\(\)](#).

The easiest way to find a suitable timebase is to call [ps6000aNearestSampleIntervalStateless\(\)](#). Alternatively, you can estimate the timebase number that you require using the information in the [timebase guide](#), then pass this timebase to [ps6000aGetTimebase\(\)](#) and check the returned `timeIntervalNanoseconds` argument. Repeat until you obtain the time interval that you need.

Applicability

All modes

Arguments

`handle`, the device identifier returned by [ps6000aOpenUnit\(\)](#).

`timebase`, [see timebase guide](#).

`noSamples`, the number of samples required. This value is used to calculate the most suitable time interval.

`timeIntervalNanoseconds`, on exit, the time interval between readings at the selected timebase. Use NULL if not required.

`maxSamples`, on exit, the maximum number of samples available. The scope allocates a certain amount of memory for internal overheads and this may vary depending on the number of segments, number of channels enabled, and the timebase chosen. Use NULL if not required.

`segmentIndex`, the index of the memory segment to use.

Returns

PICO_OK
PICO_INVALID_HANDLE
PICO_TOO_MANY_SAMPLES
PICO_INVALID_CHANNEL
PICO_INVALID_TIMEBASE
PICO_INVALID_PARAMETER
PICO_SEGMENT_OUT_OF_RANGE
PICO_DRIVER_FUNCTION

3.16 ps6000aGetTriggerInfo - get trigger timing information

```
PICO_STATUS ps6000aGetTriggerInfo
(
    int16_t          handle
    PICO_TRIGGER_INFO * triggerInfo,
    uint64_t         firstSegmentIndex,
    uint64_t         segmentCount
)
```

This function gets trigger timing information from one or more buffer segments.

Call this function after data has been captured or when data has been retrieved from a previous capture.

Applicability

[Block mode](#), [rapid block mode](#)

Arguments

`handle`, the device identifier returned by [ps6000aOpenUnit\(\)](#).

* `triggerInfo`, a list of structures, one for each buffer segment, containing trigger information.

`firstSegmentIndex`, the index of the first segment of interest.

`segmentCount`, the number of segments of interest.

Returns

PICO_OK
PICO_INVALID_HANDLE
PICO_DEVICE_SAMPLING
PICO_SEGMENT_OUT_OF_RANGE
PICO_NULL_PARAMETER
PICO_NO_SAMPLES_AVAILABLE
PICO_DRIVER_FUNCTION

3.16.1 PICO_TRIGGER_INFO

A list of structures of this type containing trigger information is written by [ps6000aGetTriggerInfo\(\)](#) to the `triggerInfo` location. The structure is defined as follows:

```
typedef struct tPicoTriggerInfo
{
    PICO_STATUS      status;
    uint64_t         segmentIndex;
    uint64_t         triggerIndex;
    double           triggerTime;
    PICO_TIME_UNITS  timeUnits;
    uint64_t         missedTriggers;
    uint64_t         timeStampCounter;
} PICO_TRIGGER_INFO;
```

The structure is byte-aligned. In C++, for example, you should specify this using the `#pragma pack()` instruction.

Elements

`status`, indicates success or failure.

`segmentIndex`, the number of the segment.

`triggerIndex`, the index of the sample at which the trigger occurred.

`triggerTime`, the time at which the trigger occurred.

`timeUnits`, the unit multiplier to use with `triggerTime`.

`missedTriggers`, the number of trigger events, if any, detected since the start of previous segment.

`timeStampCounter`, the time in samples from the first capture to the current capture. The status `PICO_DEVICE_TIME_STAMP_RESET` indicates that the trigger time has started over.

3.17 ps6000aGetTriggerTimeOffset - get timing corrections

```
PICO_STATUS ps6000aGetTriggerTimeOffset
(
    int16_t          handle
    int64_t          * time,
    PICO_TIME_UNITS * timeUnits,
    uint64_t         segmentIndex
)
```

This function gets the trigger time offset for waveforms obtained in [block mode](#) or [rapid block mode](#). The trigger time offset is an adjustment value used for correcting jitter in the waveform, and is intended mainly for applications that wish to display the waveform with reduced jitter. The offset is zero if the waveform crosses the threshold at the trigger sampling instant, or a positive or negative value if jitter correction is required. The value should be added to the nominal trigger time to get the corrected trigger time.

Call this function after data has been captured or when data has been retrieved from a previous capture.

Applicability

[Block mode](#), [rapid block mode](#)

Arguments

`handle`, the device identifier returned by [ps6000aOpenUnit\(\)](#).

`time`, on exit, the time at which the trigger point occurred

`timeUnits`, on exit, the time units in which `time` is measured. The possible values are:

[PICO_FS](#)
[PICO_PS](#)
[PICO_NS](#)
[PICO_US](#)
[PICO_MS](#)
[PICO_S](#)

`segmentIndex`, the number of the [memory segment](#) for which the information is required.

Returns

PICO_OK
PICO_INVALID_HANDLE
PICO_DEVICE_SAMPLING
PICO_SEGMENT_OUT_OF_RANGE
PICO_NULL_PARAMETER
PICO_NO_SAMPLES_AVAILABLE
PICO_DRIVER_FUNCTION

3.18 ps6000aGetUnitInfo - get information about device

```
PICO\_STATUS ps6000aGetUnitInfo  
(  
    int16_t      handle,  
    int8_t      * string,  
    int16_t      stringLength,  
    int16_t      * requiredSize  
    PICO_INFO    info  
)
```

This function retrieves information about the specified oscilloscope. If the device fails to open, only the driver version and error code are available to explain why the last open unit call failed. To find out about unopened devices, call [ps6000aEnumerateUnits\(\)](#).

Applicability

All modes

Arguments

`handle`, identifies the device from which information is required. If an invalid handle is passed, the error code from the last unit that failed to open is returned.

`string`, on exit, the unit information string selected specified by the `info` argument. If `string` is NULL, only `requiredSize` is returned.

`stringLength`, the maximum number of `int8_t` values that may be written to `string`.

`requiredSize`, on exit, the required length of the `string` array.

`info`, a number specifying what information is required. The possible values are listed in the table below.

Returns

PICO_OK
PICO_INVALID_HANDLE
PICO_NULL_PARAMETER
PICO_INVALID_INFO
PICO_INFO_UNAVAILABLE
PICO_DRIVER_FUNCTION

info		Example
0x00	PICO_DRIVER_VERSION - Version number of ps6000a DLL	1, 0, 0, 1
0x01	PICO_USB_VERSION - Type of USB connection to device: 1.1, 2.0 or 3.0	3.0
0x02	PICO_HARDWARE_VERSION - Hardware version of device	1
0x03	PICO_VARIANT_INFO - Model number of device	6403
0x04	PICO_BATCH_AND_SERIAL - Batch and serial number of device	KJL87/6
0x05	PICO_CAL_DATE - Calibration date of device	30Sep09
0x06	PICO_KERNEL_VERSION - Version of kernel driver	1, 1, 2, 4
0x07	PICO_DIGITAL_HARDWARE_VERSION - Hardware version of the digital section	1
0x08	PICO_ANALOGUE_HARDWARE_VERSION - Hardware version of the analog section	1
0x09	PICO_FIRMWARE_VERSION_1 - Version information of Firmware 1	1, 0, 0, 1
0x0A	PICO_FIRMWARE_VERSION_2 - Version information of Firmware 2	1, 0, 0, 1
0x0F	PICO_FIRMWARE_VERSION_3 - Version information of Firmware 3	1, 0, 0, 1
0x10	PICO_FRONT_PANEL_FIRMWARE_VERSION - Version of front-panel microcontroller firmware	1, 0, 0, 1

3.19 ps6000aGetValues - get block mode data

```
PICO_STATUS ps6000aGetValues
(
    int16_t          handle,
    uint64_t         startIndex,
    uint64_t         * noOfSamples,
    uint64_t         downSampleRatio,
    PICO_RATIO_MODE downSampleRatioMode,
    uint64_t         segmentIndex,
    int16_t          * overflow
)
```

This function retrieves block-mode data, either with or without downsampling, starting at the specified sample number. It is used to get the stored data from the scope after data collection has stopped, and store it in a user buffer previously passed to [ps6000aSetDataBuffer\(\)](#) or [ps6000aSetDataBuffers\(\)](#). It blocks the calling function while retrieving data.

Applicability

All modes.

Arguments

`handle`, the device identifier returned by [ps6000aOpenUnit\(\)](#).

`startIndex`, a zero-based index that indicates the start point for data collection. It is measured in sample intervals from the start of the buffer.

`noOfSamples`, on entry, the number of raw samples to be processed. On exit, the actual number retrieved. The number of samples retrieved will not be more than the number requested, and the data retrieved always starts with the first sample captured.

`downSampleRatio`, the [downsampling](#) factor that will be applied to the raw data. Must be greater than zero.

`downSampleRatioMode`, which [downsampling](#) mode to use. The available values are:

```
PICO_RATIO_MODE_AGGREGATE
PICO_RATIO_MODE_DECIMATE
PICO_RATIO_MODE_AVERAGE
PICO_RATIO_MODE_TRIGGER - cannot be combined with any other ratio mode
PICO_RATIO_MODE_RAW
```

`segmentIndex`, the zero-based number of the [memory segment](#) where the data is stored.

`overflow`, on exit, a set of flags that indicate whether an overvoltage has occurred on any of the channels. It is a bit field with bit 0 denoting Channel A.

Returns

PICO_OK
PICO_INVALID_HANDLE
PICO_NO_SAMPLES_AVAILABLE
PICO_DEVICE_SAMPLING
PICO_NULL_PARAMETER
PICO_SEGMENT_OUT_OF_RANGE
PICO_INVALID_PARAMETER
PICO_TOO_MANY_SAMPLES
PICO_DATA_NOT_AVAILABLE
PICO_STARTINDEX_INVALID
PICO_INVALID_SAMPLERATIO
PICO_INVALID_CALL
PICO_NOT_RESPONDING
PICO_MEMORY
PICO_RATIO_MODE_NOT_SUPPORTED
PICO_DRIVER_FUNCTION

3.19.1 Downsampling modes

Various methods of data reduction, or **downsampling**, are possible with the PicoScope 6000E Series oscilloscopes. The downsampling is done at high speed by dedicated hardware inside the scope, making your application faster and more responsive than if you had to do all the data processing in software.

You specify the downsampling mode when you call one of the data collection functions, such as [ps6000aGetValues\(\)](#). The following modes are available:

PICO_RATIO_MODE_AGGREGATE	Reduces every block of n values to just two values: a minimum and a maximum. The minimum and maximum values are returned in two separate buffers.
PICO_RATIO_MODE_AVERAGE	Reduces every block of n values to a single value representing the average (arithmetic mean) of all the values.
PICO_RATIO_MODE_DECIMATE	Reduces every block of n values to just the first value in the block, discarding all the other values.
PICO_RATIO_MODE_DISTRIBUTION	Not implemented.
PICO_RATIO_MODE_TRIGGER	Gets 20 samples either side of the trigger point.
PICO_RATIO_MODE_RAW	No downsampling. Returns raw data values.

3.20 ps6000aGetValuesAsync - read data without blocking

```
PICO_STATUS ps6000aGetValuesAsync
(
    int16_t          handle,
    uint64_t         startIndex,
    uint64_t         noOfSamples,
    uint64_t         downSampleRatio,
    PICO_RATIO_MODE downSampleRatioMode,
    uint64_t         segmentIndex,
    PICO_POINTER     lpDataReady,
    PICO_POINTER     pParameter
)
```

This function obtains data from the oscilloscope, with [downsampling](#) if requested, starting at the specified sample number. It delivers the data using a [callback](#).

Applicability

[Streaming mode](#) and [block mode](#)

Arguments

handle,
 startIndex,
 noOfSamples,
 downSampleRatio,
 downSampleRatioMode,
 segmentIndex: see [ps6000aGetValues\(\)](#)

lpDataReady, a pointer to the user-supplied function that will be called when the data is ready. For compatibility with older applications the driver also supports a [ps6000aDataReady\(\)](#) function.

pParameter, a void pointer that will be passed to the callback function. The data type is determined by the application.

Returns

PICO_OK
 PICO_INVALID_HANDLE
 PICO_NO_SAMPLES_AVAILABLE
 PICO_DEVICE_SAMPLING
 PICO_NULL_PARAMETER
 PICO_STARTINDEX_INVALID
 PICO_SEGMENT_OUT_OF_RANGE
 PICO_INVALID_PARAMETER
 PICO_DATA_NOT_AVAILABLE
 PICO_INVALID_SAMPLERATIO
 PICO_INVALID_CALL
 PICO_DRIVER_FUNCTION

3.21 ps6000aGetValuesBulk - read multiple segments

```
PICO\_STATUS ps6000aGetValuesBulk
(
    int16_t          handle,
    uint64_t         startIndex,
    uint64_t         * noOfSamples,
    uint64_t         fromSegmentIndex,
    uint64_t         toSegmentIndex,
    uint64_t         downSampleRatio,
    PICO_RATIO_MODE downSampleRatioMode,
    int16_t          * overflow
)
```

This function retrieves waveforms captured using [rapid block mode](#). The waveforms must have been collected sequentially and in the same run.

Applicability

[Rapid block mode](#)

Arguments

handle, startIndex, noOfSamples, downSampleRatio, downSampleRatioMode, overflow: see [ps6000aGetValues\(\)](#)

fromSegmentIndex, toSegmentIndex: zero-based numbers of the first and last [memory segments](#) where the data is stored.

Returns

```
PICO_OK
PICO_INVALID_HANDLE
PICO_INVALID_PARAMETER
PICO_SEGMENT_OUT_OF_RANGE
PICO_NO_SAMPLES_AVAILABLE
PICO_STARTINDEX_INVALID
PICO_NOT_RESPONDING
PICO_DRIVER_FUNCTION
PICO_INVALID_SAMPLERATIO
```

3.22 ps6000aGetValuesBulkAsync - read multiple segments without blocking

```

PICO_STATUS ps6000aGetValuesBulkAsync
(
    int16_t          handle,
    uint64_t         startIndex,
    uint64_t         noOfSamples,
    uint64_t         fromSegmentIndex,
    uint64_t         toSegmentIndex,
    uint64_t         downSampleRatio,
    PICO_RATIO_MODE downSampleRatioMode,
    PICO_POINTER     lpDataReady,
    PICO_POINTER     pParameter
)

```

This function retrieves more than one waveform at a time from the driver in [rapid block mode](#) after data collection has stopped. The waveforms must have been collected sequentially and in the same run. The data is returned using a [callback](#).

Applicability

[Rapid block mode](#)

Arguments

handle,
 startIndex,
 noOfSamples,
 downSampleRatio,
 downSampleRatioMode: see [ps6000aGetValues\(\)](#)

fromSegmentIndex,
 toSegmentIndex: see [ps6000aGetValuesBulk\(\)](#)

lpDataReady,
 pParameter

Returns

PICO_OK
 PICO_INVALID_HANDLE
 PICO_INVALID_PARAMETER
 PICO_SEGMENT_OUT_OF_RANGE
 PICO_NO_SAMPLES_AVAILABLE
 PICO_STARTINDEX_INVALID
 PICO_NOT_RESPONDING
 PICO_DRIVER_FUNCTION

3.23 ps6000aGetValuesOverlapped - get rapid block data

```
PICO_STATUS ps6000aGetValuesOverlapped
(
    int16_t          handle,
    uint64_t         startIndex,
    uint64_t         * noOfSamples,
    uint64_t         downSampleRatio,
    PICO_RATIO_MODE downSampleRatioMode,
    uint64_t         fromSegmentIndex,
    uint64_t         toSegmentIndex,
    int16_t          * overflow
)
```

This function allows you to make a deferred data-collection request in rapid block mode. The request will be executed, and the arguments validated, when you call [ps6000aRunBlock\(\)](#). The advantage of this method is that the driver makes contact with the scope only once, when you call [ps6000aRunBlock\(\)](#), compared with the two contacts that occur when you use the conventional [ps6000aRunBlock\(\)](#), [ps6000aGetValues\(\)](#) calling sequence. This slightly reduces the dead time between successive captures in rapid block mode.

After calling [ps6000aRunBlock\(\)](#), you can optionally use [ps6000aGetValues\(\)](#) to request further copies of the data. This might be required if you wish to display the data with different data reduction settings.

To stop collecting data, call [ps6000aStopUsingGetValuesOverlapped\(\)](#).

Applicability

[Rapid block mode](#)

Arguments

handle,
 startIndex,
 * noOfSamples,
 downSampleRatio,
 downSampleRatioMode: see [ps6000aGetValues\(\)](#)

fromSegmentIndex,
 toSegmentIndex,
 * overflow, see [ps6000aGetValuesBulk\(\)](#).

Returns

PICO_OK
 PICO_INVALID_HANDLE
 PICO_INVALID_PARAMETER
 PICO_DRIVER_FUNCTION

3.23.1 Using GetValuesOverlapped()

1. Open the oscilloscope using [ps6000aOpenUnit\(\)](#).
2. Select channel ranges and AC/DC coupling using [ps6000aSetChannelOn\(\)](#).
3. Using [ps6000aGetTimebase\(\)](#), select timebases until the required nanoseconds per sample is located.
4. Use the trigger setup functions [ps6000aSetTriggerChannelConditions\(\)](#), [ps6000aSetTriggerChannelDirections\(\)](#) and [ps6000aSetTriggerChannelProperties\(\)](#) to set up the trigger if required.
5. Use [ps6000aSetDataBuffer\(\)](#) to tell the driver where your memory buffer is.
6. Set up the transfer of the block of data from the oscilloscope using [ps6000aGetValuesOverlapped\(\)](#).
7. Start the oscilloscope running using [ps6000aRunBlock\(\)](#).
8. Wait until the oscilloscope is ready using the [ps6000aBlockReady\(\)](#) callback (or poll using [ps6000aIsReady\(\)](#)).
9. Display the data.
10. Repeat steps 7 to 9 if needed.
11. Stop the oscilloscope by calling [ps6000aStop\(\)](#).

A similar procedure can be used with [rapid block mode](#).

3.24 ps6000aGetValuesTriggerTimeOffsetBulk - get trigger time offsets for multiple segments

```
PICO_STATUS ps6000aGetValuesTriggerTimeOffsetBulk
(
    int16_t          handle,
    int64_t          * times,
    PICO_TIME_UNITS * timeUnits,
    uint64_t         fromSegmentIndex,
    uint64_t         toSegmentIndex
)
```

This function retrieves the trigger time offset for multiple waveforms obtained in [block mode](#) or [rapid block mode](#). It is a more efficient alternative to calling [ps6000aGetTriggerTimeOffset\(\)](#) once for each waveform required. See [ps6000aGetTriggerTimeOffset\(\)](#) for an explanation of trigger time offsets.

Applicability

[Rapid block mode](#)

Arguments

`handle`, the device identifier returned by [ps6000aOpenUnit\(\)](#).

* `times`, an array of integers. On exit, the time offset for each requested segment index. `times[0]` will hold the `fromSegmentIndex` time offset and the last `times[]` index will hold the `toSegmentIndex` time offset. The array must be long enough to hold the number of requested times.

* `timeUnits`, an array of integers. The array must be long enough to hold the number of requested times. On exit, `timeUnits[0]` will contain the time unit for `fromSegmentIndex` and the last element will contain the time unit for `toSegmentIndex`. PICO_TIME_UNITS values are listed under [ps6000aGetTriggerTimeOffset\(\)](#).

`fromSegmentIndex`, the first segment for which the time offset is required

`toSegmentIndex`, the last segment for which the time offset is required. If `toSegmentIndex` is less than `fromSegmentIndex` then the driver will wrap around from the last segment to the first.

Returns

PICO_OK
PICO_INVALID_HANDLE
PICO_NULL_PARAMETER
PICO_DEVICE_SAMPLING
PICO_SEGMENT_OUT_OF_RANGE
PICO_NO_SAMPLES_AVAILABLE
PICO_DRIVER_FUNCTION

3.25 ps6000aIsReady - get status of block capture

```
PICO\_STATUS ps6000aIsReady  
(  
    int16_t    handle,  
    int16_t    * ready  
)
```

This function may be used instead of a callback function to receive data from [ps6000aRunBlock\(\)](#). To use this method, pass a NULL pointer as the `lpReady` argument to [ps6000aRunBlock\(\)](#). You must then poll the driver to see if it has finished collecting the requested samples.

Applicability

[Block mode](#)

Arguments

`handle`, the device identifier returned by [ps6000aOpenUnit\(\)](#).

`ready`, output: indicates the state of the collection. If zero, the device is still collecting. If non-zero, the device has finished collecting and [ps6000aGetValues\(\)](#) can be used to retrieve the data.

Returns

3.26 ps6000aMemorySegments - set number of memory segments

```
PICO_STATUS ps6000aMemorySegments  
(  
    int16_t    handle  
    uint64_t   nSegments,  
    uint64_t   * nMaxSamples  
)
```

This function sets the number of memory segments that the scope will use.

When the scope is [opened](#), the number of segments defaults to 1, meaning that each capture fills the scope's available memory. This function allows you to divide the memory into a number of segments so that the scope can store several waveforms sequentially.

Applicability

All modes

Arguments

`handle`, the device identifier returned by [ps6000aOpenUnit\(\)](#).

`nSegments`, the number of segments required. See data sheet for capacity of each model.

* `nMaxSamples`, on exit, the number of samples available in each segment. This is the total number over all channels, so if more than one channel is in use then the number of samples available to each channel is `nMaxSamples` divided by the number of channels.

Returns

PICO_OK
PICO_USER_CALLBACK
PICO_INVALID_HANDLE
PICO_TOO_MANY_SEGMENTS
PICO_MEMORY
PICO_DRIVER_FUNCTION

3.27 ps6000aMemorySegmentsBySamples - set size of memory segments

```
PICO_STATUS ps6000aMemorySegmentsBySamples  
(  
    int16_t    handle  
    uint64_t   nSamples,  
    uint64_t   * nMaxSegments  
)
```

This function sets the number of samples per memory segment. Like [ps6000aMemorySegments\(\)](#) it controls the segmentation of the capture memory, but in this case you specify the number of samples rather than the number of segments.

Applicability

All modes

Arguments

`handle`, the device identifier returned by [ps6000aOpenUnit\(\)](#).

`nSamples`, the number of samples required in each segment. See data sheet for capacity of each model. This is the total number over n channels, where n is the number of enabled channels or MSO ports rounded up to the next power of 2. For example, with 5 channels or ports enabled, n is 8. If $n > 1$, the number of segments available will be reduced accordingly.

* `nMaxSegments`, on exit, the number of segments into which the capture memory has been divided.

Returns

PICO_OK
PICO_USER_CALLBACK
PICO_INVALID_HANDLE
PICO_TOO_MANY_SEGMENTS
PICO_MEMORY
PICO_DRIVER_FUNCTION

3.28 ps6000aNearestSampleIntervalStateless - get nearest sampling interval

```
PICO_STATUS ps6000aNearestSampleIntervalStateless
(
    int16_t                handle,
    PICO_CHANNEL_FLAGS    enabledChannelFlags,
    double                 timeIntervalRequested,
    PICO_DEVICE_RESOLUTION resolution,
    uint32_t               * timebase,
    double                 * timeIntervalAvailable
)
```

This function returns the nearest possible sample interval to the requested sample interval. It does not change the configuration of the oscilloscope.

Applicability

All modes

Arguments

`handle`, the device identifier returned by [ps6000aOpenUnit\(\)](#).

`enabledChannelFlags`, see [ps6000aGetMinimumTimebaseStateless\(\)](#).

`timeIntervalRequested`, the time interval, in seconds, that you would like to obtain.

`resolution`, the vertical resolution (number of bits) for which the oscilloscope will be configured.

* `timebase`, on exit, the number of the nearest available timebase.

* `timeIntervalAvailable`, on exit, the nearest available time interval, in seconds.

Returns

PICO_OK
PICO_INVALID_HANDLE
PICO_NO_SAMPLES_AVAILABLE
PICO_NULL_PARAMETER
PICO_INVALID_PARAMETER
PICO_SEGMENT_OUT_OF_RANGE
PICO_TOO_MANY_SAMPLES

3.29 ps6000aNoOfStreamingValues - get number of captured samples

```
PICO_STATUS ps6000aNoOfStreamingValues  
(  
    int16_t    handle,  
    uint64_t  * noOfValues  
)
```

This function returns the number of samples available after data collection in [streaming mode](#). Call it after calling [ps6000aStop\(\)](#).

Applicability

[Streaming mode](#)

Arguments

handle, the device identifier returned by [ps6000aOpenUnit\(\)](#).

* noOfValues, on exit, the number of samples.

Returns

PICO_OK
PICO_INVALID_HANDLE
PICO_NULL_PARAMETER
PICO_NO_SAMPLES_AVAILABLE
PICO_NOT_USED
PICO_BUSY
PICO_DRIVER_FUNCTION

3.30 ps6000aOpenUnit - open a scope device

```
PICO_STATUS ps6000aOpenUnit
(
    int16_t          * handle,
    int8_t           * serial,
    PICO_DEVICE_RESOLUTION resolution
)
```

This function opens a PicoScope 6000E Series scope attached to the computer. The maximum number of units that can be opened depends on the operating system, the kernel driver and the computer.

If the function returns `PICO_FIRMWARE_UPDATE_REQUIRED_TO_USE_DEVICE_WITH_THIS_DRIVER`, all other API calls that perform operations with the same device will fail with the same return value until [ps6000aStartFirmwareUpdate\(\)](#) is called. Users should avoid unplugging the device during this operation, otherwise there is a small chance that the firmware could be corrupted.

Applicability

All modes

Arguments

- * `handle`, on exit, the result of the attempt to open a scope:
 - 1 : if the scope fails to open
 - 0 : if no scope is found
 - > 0 : a number that uniquely identifies the scope

If a valid handle is returned, it must be used in all subsequent calls to API functions to identify this scope.

`serial`, on entry, a null-terminated string containing the serial number of the scope to be opened. If `serial` is NULL then the function opens the first scope found; otherwise, it tries to open the scope that matches the string.

`resolution`, the required vertical resolution (in bits).

Returns

`PICO_OK`
`PICO_OS_NOT_SUPPORTED`
`PICO_OPEN_OPERATION_IN_PROGRESS`
`PICO_EEPROM_CORRUPT`
`PICO_KERNEL_DRIVER_TOO_OLD`
`PICO_FW_FAIL`
`PICO_MAX_UNITS_OPENED`
`PICO_NOT_FOUND` (if the specified unit was not found)
`PICO_NOT_RESPONDING`
`PICO_MEMORY_FAIL`
`PICO_ANALOG_BOARD`
`PICO_CONFIG_FAIL_AWG`
`PICO_INITIALISE_FPGA`
`PICO_FIRMWARE_UPDATE_REQUIRED_TO_USE_DEVICE_WITH_THIS_DRIVER` - call [ps6000aCheckForUpdate\(\)](#) and then [ps6000aStartFirmwareUpdate\(\)](#)

3.31 ps6000aOpenUnitAsync - open unit without blocking

```
PICO_STATUS ps6000aOpenUnitAsync  
(  
    int16_t          * status,  
    int8_t           * serial,  
    PICO_DEVICE_RESOLUTION resolution  
)
```

This function opens a scope without blocking the calling thread. You can find out when it has finished by periodically calling [ps6000aOpenUnitProgress\(\)](#) until that function sets the complete flag to a non-zero value.

Applicability

All modes

Arguments

* `status`, a status code:
 0 if the open operation was disallowed because another open operation is in progress
 1 if the open operation was successfully started

* `serial`, see [ps6000aOpenUnit\(\)](#).

`resolution`, the vertical resolution required.

Returns

PICO_OK
PICO_OPEN_OPERATION_IN_PROGRESS
PICO_OPERATION_FAILED

3.32 ps6000aOpenUnitProgress - get status of opening a unit

```
PICO_STATUS ps6000aOpenUnitProgress  
(  
    int16_t * handle,  
    int16_t * progressPercent,  
    int16_t * complete  
)
```

This function checks on the progress of a request made to [ps6000aOpenUnitAsync\(\)](#) to open a scope.

Applicability

Use after [ps6000aOpenUnitAsync\(\)](#)

Arguments

- * `handle`, see [ps6000aOpenUnit\(\)](#). This handle is valid only if the function returns `PICO_OK`.
- * `progressPercent`, on exit, 0 while the operation is in progress, 100 when the operation is complete.
- * `complete`, set to 1 when the open operation has finished.

Returns

`PICO_OK`
`PICO_NULL_PARAMETER`
`PICO_OPERATION_FAILED`

3.33 ps6000aPingUnit - check if device is still connected

```
PICO\_STATUS ps6000aPingUnit  
(  
    int16_t    handle  
)
```

This function can be used to check that the already opened device is still connected to the USB port and communication is successful.

Applicability

All modes

Arguments

`handle`, the device identifier returned by [ps6000aOpenUnit\(\)](#).

Returns

PICO_OK
PICO_INVALID_HANDLE
PICO_DRIVER_FUNCTION
PICO_BUSY
PICO_NOT_RESPONDING

3.34 ps6000aQueryMaxSegmentsBySamples - get number of segments

```
PICO_STATUS ps6000aQueryMaxSegmentsBySamples  
(  
    int16_t          handle,  
    uint64_t         nSamples,  
    uint32_t         nChannelEnabled,  
    uint64_t         * nMaxSegments,  
    PICO_DEVICE_RESOLUTION resolution  
)
```

This function returns the maximum number of memory segments available given the number of samples per segment.

Applicability

All modes

Arguments

`handle`, the device identifier returned by [ps6000aOpenUnit\(\)](#).

`nSamples`, the number of samples per segment.

`nChannelEnabled`, the number of channels enabled.

* `nMaxSegments`, on exit, the maximum number of segments that can be requested.

`resolution`, an enumerated type representing the hardware resolution.

Returns

PICO_OK
PICO_INVALID_HANDLE
PICO_NO_SAMPLES_AVAILABLE
PICO_NULL_PARAMETER
PICO_INVALID_PARAMETER
PICO_SEGMENT_OUT_OF_RANGE
PICO_TOO_MANY_SAMPLES

3.35 ps6000aQueryOutputEdgeDetect – check if output edge detection is enabled

```
PICO\_STATUS ps6000aQueryOutputEdgeDetect  
(  
    int16_t    handle,  
    int16_t * state  
)
```

This function reports whether output edge detection mode is currently enabled. The default state is enabled.

To switch output edge detection mode on or off, use [ps6000aSetOutputEdgeDetect](#). See that function description for more details.

Applicability

All modes

Arguments

`handle`, the device identifier returned by [ps6000aOpenUnit\(\)](#).

* `state`, on exit, the state of output edge detection:

0 = off

1 = on

Returns

PICO_OK or other code from `PicoStatus.h`

3.36 ps6000aResetChannelsAndReportAllChannelsOvervoltageTripStatus

```
PICO_STATUS ps6000aResetChannelsAndReportAllChannelsOvervoltageTripStatus
(
    int16_t                handle,
    PICO_CHANNEL_OVERVOLTAGE_TRIPPED * allChannelsTrippedStatus,
    uint8_t                nChannelTrippedStatus
)
```

This function resets all oscilloscope channels and then reports the overvoltage trip status for all channels. Use this to find out which channels caused an overvoltage trip event.

Applicability

All modes

Arguments

`handle`, the device identifier returned by [ps6000aOpenUnit\(\)](#).

`allChannelsTrippedStatus`, a pointer to an array of [PICO_CHANNEL_OVERVOLTAGE_TRIPPED](#) structs. On exit, the overvoltage trip status of each channel will be written to this array.

`nChannelTrippedStatus`, the number of [PICO_CHANNEL_OVERVOLTAGE_TRIPPED](#) structs in the above array..

Returns

PICO_OK
PICO_INVALID_HANDLE
PICO_DRIVER_FUNCTION
PICO_HARDWARE_CAPTURING_CALL_STOP
PICO_NULL_PARAMETER
PICO_INVALID_PARAMETER
PICO_NOT_SUPPORTED_BY_THIS_DEVICE

3.37 ps6000aReportAllChannelsOvervoltageTripStatus

```
PICO_STATUS ps6000aReportAllChannelsOvervoltageTripStatus
(
    int16_t                handle,
    PICO_CHANNEL_OVERVOLTAGE_TRIPPED * allChannelsTrippedStatus,
    uint8_t                nChannelTrippedStatus
)
```

This function reports the overvoltage trip status for all channels without resetting their status. Use it to find out which channels caused an overvoltage trip event.

Applicability

All modes

Arguments

`handle`, the device identifier returned by [ps6000aOpenUnit\(\)](#).

`allChannelsTrippedStatus`, a pointer to an array of [PICO_CHANNEL_OVERVOLTAGE_TRIPPED](#) channel status flags. On exit, the overvoltage trip status of each channel will be written to this array.

`nChannelTrippedStatus`, the number of [PICO_CHANNEL_OVERVOLTAGE_TRIPPED](#) structs in the above array..

Returns

PICO_OK
PICO_INVALID_HANDLE
PICO_DRIVER_FUNCTION
PICO_NULL_PARAMETER
PICO_INVALID_PARAMETER
PICO_NOT_SUPPORTED_BY_THIS_DEVICE

3.37.1 PICO_CHANNEL_OVERVOLTAGE_TRIPPED structure

```
typedef struct tPicoChannelOvervoltageTripped
{
    PICO_CHANNEL    channel_;
    uint8_t         tripped_;
} PICO_CHANNEL_OVERVOLTAGE_TRIPPED;
```

This structure contains information about the overvoltage trip on a given channel. An overvoltage trip occurs when an oscilloscope channel in 50 Ω coupling mode detects an excessive voltage on its input.

Applicability

Analog input channels

Elements

`channel_`, the oscilloscope channel to which the information applies.

`tripped_`, a flag indicating whether the overvoltage trip occurred (non-zero) or did not occur (zero).

3.38 ps6000aRunBlock - start block mode capture

```

PICO_STATUS ps6000aRunBlock
(
    int16_t          handle,
    uint64_t         noOfPreTriggerSamples,
    uint64_t         noOfPostTriggerSamples,
    uint32_t         timebase,
    double           * timeIndisposedMs,
    uint64_t         segmentIndex,
    ps6000aBlockReady lpReady,
    PICO_POINTER     pParameter
)

```

This function starts collecting data in [block mode](#). For a step-by-step guide to this process, see [Using block mode](#).

The number of samples is determined by `noOfPreTriggerSamples` and `noOfPostTriggerSamples` (see below for details). The total number of samples must not be more than the size of the [segment](#) referred to by `segmentIndex`.

Applicability

[Block mode](#), [rapid block mode](#)

Arguments

`handle`, the device identifier returned by [ps6000aOpenUnit\(\)](#).

`noOfPreTriggerSamples`, the number of samples to return before the trigger event. If no trigger has been set, then this argument is added to `noOfPostTriggerSamples` to give the maximum number of data points (samples) to collect.

`noOfPostTriggerSamples`, the number of samples to return after the trigger event. If no trigger event has been set, then this argument is added to `noOfPreTriggerSamples` to give the maximum number of data points to collect. If a trigger condition has been set, this specifies the number of data points to collect after a trigger has fired, and the number of samples to be collected is:

$$\text{noOfPreTriggerSamples} + \text{noOfPostTriggerSamples}$$

`timebase`, a number in the range 0 to $2^{32}-1$. See the [guide to calculating timebase values](#).

* `timeIndisposedMs`, on exit, the time in milliseconds that the scope will spend collecting samples. This does not include any auto trigger timeout. If this pointer is null, nothing will be written here.

`segmentIndex`, zero-based, specifies which [memory segment](#) to use.

`lpReady`, a pointer to the [ps6000aBlockReady\(\)](#) callback function that the driver will call when the data has been collected. To use the [ps6000aIsReady\(\)](#) polling method instead of a callback function, set this pointer to NULL.

`pParameter`, a void pointer that is passed to the [ps6000aBlockReady\(\)](#) callback function. The callback can use this pointer to return arbitrary data to the application.

Returns

PICO_OK

PICO_INVALID_HANDLE
PICO_USER_CALLBACK
PICO_SEGMENT_OUT_OF_RANGE
PICO_INVALID_CHANNEL
PICO_INVALID_TRIGGER_CHANNEL
PICO_INVALID_CONDITION_CHANNEL
PICO_TOO_MANY_SAMPLES
PICO_INVALID_TIMEBASE
PICO_NOT_RESPONDING
PICO_CONFIG_FAIL
PICO_INVALID_PARAMETER
PICO_NOT_RESPONDING
PICO_TRIGGER_ERROR
PICO_DRIVER_FUNCTION
PICO_EXTERNAL_FREQUENCY_INVALID
PICO_FW_FAIL
PICO_NOT_ENOUGH_SEGMENTS (in Bulk mode)
PICO_TRIGGER_AND_EXTERNAL_CLOCK_CLASH
PICO_PWQ_AND_EXTERNAL_CLOCK_CLASH
PICO_PULSE_WIDTH_QUALIFIER
PICO_SEGMENT_OUT_OF_RANGE (in Overlapped mode)
PICO_STARTINDEX_INVALID (in Overlapped mode)
PICO_INVALID_SAMPLERATIO (in Overlapped mode)
PICO_CONFIG_FAIL
PICO_SIGGEN_GATING_AUXIO_ENABLED (signal generator is set to trigger on AUX input with incompatible trigger type)

3.39 ps6000aRunStreaming - start streaming mode capture

```
PICO_STATUS ps6000aRunStreaming
(
    int16_t          handle,
    double           * sampleInterval,
    PICO_TIME_UNITS sampleIntervalTimeUnits
    uint64_t         maxPreTriggerSamples,
    uint64_t         maxPostTriggerSamples,
    int16_t          autoStop,
    uint64_t         downSampleRatio,
    PICO_RATIO_MODE  downSampleRatioMode
)
```

This function tells the oscilloscope to start collecting data in [streaming mode](#). The device can return either raw or [downsampled](#) data to your application while streaming is in progress. Call [ps6000aGetStreamingLatestValues\(\)](#) to retrieve the data. See [Using streaming mode](#) for a step-by-step guide to this process.

When a trigger is set, the total number of samples is the sum of `maxPreTriggerSamples` and `maxPostTriggerSamples`. If `autoStop` is false then this will become the maximum number of samples without downsampling.

When downsampled data is returned, the raw samples remain stored on the device. The maximum number of raw samples that can be retrieved after streaming has stopped is $(\text{scope's memory size}) / (\text{resolution data size} * \text{channels})$, where `channels` is the number of active channels rounded up to a power of 2.

Applicability

[Streaming mode](#)

Arguments

`handle`, the device identifier returned by [ps6000aOpenUnit\(\)](#).

* `sampleInterval`, on entry, the requested time interval between samples; on exit, the actual time interval used

`sampleIntervalTimeUnits`, the unit of time used for `sampleInterval`. Use one of these values:

[PICO_FS](#)
[PICO_PS](#)
[PICO_NS](#)
[PICO_US](#)
[PICO_MS](#)
[PICO_S](#)

`maxPreTriggerSamples`, the maximum number of raw samples before a trigger event for each enabled channel. If no trigger condition is set this argument is ignored.

`maxPostTriggerSamples`, the maximum number of raw samples after a trigger event for each enabled channel. If no trigger condition is set, this argument states the maximum number of samples to be stored.

`autoStop`, a flag that specifies if the streaming should stop when all of `maxSamples` have been captured.

`downSampleRatio`, `downSampleRatioMode`: see [ps6000aGetValues\(\)](#).

Returns

PICO_OK
PICO_INVALID_HANDLE
PICO_USER_CALLBACK
PICO_NULL_PARAMETER
PICO_INVALID_PARAMETER
PICO_STREAMING_FAILED
PICO_NOT_RESPONDING
PICO_TRIGGER_ERROR
PICO_INVALID_SAMPLE_INTERVAL
PICO_INVALID_BUFFER
PICO_DRIVER_FUNCTION
PICO_EXTERNAL_FREQUENCY_INVALID
PICO_FW_FAIL
PICO_TRIGGER_AND_EXTERNAL_CLOCK_CLASH
PICO_PWQ_AND_EXTERNAL_CLOCK_CLASH
PICO_MEMORY
PICO_SIGGEN_GATING_AUXIO_ENABLED (signal generator is set to trigger on AUX input with incompatible trigger type)

3.40 ps6000aSetChannelOff - disable one channel

```
PICO\_STATUS ps6000aSetChannelOff  
(  
    int16_t      handle,  
    PICO_CHANNEL channel  
)
```

This function switches an analog input channel off. It has the opposite function to [ps6000aSetChannelOn\(\)](#).

Applicability

All modes

Arguments

`handle`, the device identifier returned by [ps6000aOpenUnit\(\)](#).

`channel`, see [ps6000aSetChannelOn\(\)](#).

Returns

PICO_OK
PICO_USER_CALLBACK
PICO_INVALID_HANDLE
PICO_INVALID_CHANNEL
PICO_DRIVER_FUNCTION

3.41 ps6000aSetChannelOn - enable and set options for one channel

```
PICO_STATUS ps6000aSetChannelOn
(
    int16_t                handle,
    PICO_CHANNEL           channel,
    PICO_COUPLING          coupling,
    PICO_CONNECT_PROBE_RANGE range,
    double                 analogueOffset,
    PICO_BANDWIDTH_LIMITER bandwidth
)
```

This function switches an analog input channel on and specifies its input coupling type, voltage range, analog offset and bandwidth limit. Some of the arguments within this function have model-specific values. Consult the relevant section below according to the model you have.

To switch off, use [ps6000aSetChannelOff\(\)](#).

For digital ports, see [ps6000aSetDigitalPortOn\(\)](#).

Applicability

All modes

Arguments

`handle`, the device identifier returned by [ps6000aOpenUnit\(\)](#).

`channel`, the channel to be configured. The values (subject to the number of channels on your oscilloscope model) are:

[PICO_CHANNEL_A](#), [PICO_CHANNEL_B](#), [PICO_CHANNEL_C](#), [PICO_CHANNEL_D](#),
[PICO_CHANNEL_E](#), [PICO_CHANNEL_F](#), [PICO_CHANNEL_G](#), [PICO_CHANNEL_H](#)

`coupling`, the impedance and coupling type. The values supported are:

`PICO_AC`, 1 MΩ impedance, AC coupling. The channel accepts input frequencies from about 1 hertz up to its maximum -3 dB analog bandwidth.*

`PICO_DC`, 1 MΩ impedance, DC coupling. The scope accepts all input frequencies from zero (DC) up to its maximum -3 dB analog bandwidth.*

`PICO_DC_500HM`, 50 Ω impedance, DC coupling. The higher-voltage input ranges may not be available in this mode - consult data sheet.

`range`, the input voltage range (not applicable to intelligent probes – see below):

[PICO_10MV](#): ±10 mV*
[PICO_20MV](#): ±20 mV*
[PICO_50MV](#): ±50 mV
[PICO_100MV](#): ±100 mV
[PICO_200MV](#): ±200 mV
[PICO_500MV](#): ±500 mV
[PICO_1V](#): ±1 V*
[PICO_2V](#): ±2 V*
[PICO_5V](#): ±5 V*
[PICO_10V](#): ±10 V**

PICO_20V: ± 20 V**

* not available for the PicoScope 6428E-D

** not available when `coupling = PICO_DC_50R`

For an intelligent probe (one with internal electronics to identify the probe and set ranges automatically), you cannot set the oscilloscope range directly. If you try to, the function will return `PICO_WARNING_PROBE_CHANNEL_OUT_OF_SYNC`. Instead, use the `PICO_CONNECT_PROBE_RANGE` values which are applicable to the connected probe. The available range values for the currently-connected probe are passed to your `PicoProbeInteractions()` callback when a probe is detected by the oscilloscope.

`analogueOffset`, a voltage to add to the input channel before digitization.

`bandwidth`, the bandwidth limiter setting:

`PICO_BW_FULL`: the scope's full specified bandwidth

`PICO_BW_20MHZ`: -3 dB bandwidth limited to 20 MHz

`PICO_BW_200MHZ`: -3 dB bandwidth limited to 200 MHz (for scopes with 750 MHz bandwidth and above)

Returns

`PICO_OK`

`PICO_USER_CALLBACK`

`PICO_INVALID_HANDLE`

`PICO_INVALID_CHANNEL`

`PICO_INVALID_VOLTAGE_RANGE`

`PICO_INVALID_COUPLING`

`PICO_COUPLING_NOT_SUPPORTED`

`PICO_INVALID_ANALOGUE_OFFSET`

`PICO_INVALID_BANDWIDTH`

`PICO_BANDWIDTH_NOT_SUPPORTED`

`PICO_DRIVER_FUNCTION`

`PICO_WARNING_PROBE_CHANNEL_OUT_OF_SYNC`

3.42 ps6000aSetDataBuffer - provide location of data buffer

```
PICO_STATUS ps6000aSetDataBuffer
(
    int16_t          handle,
    PICO_CHANNEL     channel,
    PICO_POINTER     buffer,
    int32_t          nSamples,
    PICO_DATA_TYPE   dataType,
    uint64_t         waveform,
    PICO_RATIO_MODE  downSampleRatioMode,
    PICO_ACTION      action
)
```

This function tells the driver where to store the data, either unprocessed or [downsampled](#), that will be returned after the next call to one of the `GetValues` functions. The function allows you to specify only a single buffer, so for aggregation mode, which requires two buffers, you must call [ps6000aSetDataBuffers\(\)](#) instead.

The buffer persists between captures until it is replaced with another buffer or `buffer` is set to `NULL`. The buffer can be replaced at any time between calls to [ps6000aGetValues\(\)](#).

You must allocate memory for the buffer before calling this function.

Applicability

[Block](#), [rapid block](#) and [streaming](#) modes. All [downsampling](#) modes except [aggregation](#).

Arguments

`handle`, the device identifier returned by [ps6000aOpenUnit\(\)](#).

`channel`, the channel you want to use with the buffer.

`buffer`, the location of the buffer.

`nSamples`, the length of the buffer array.

`dataType`, the data type that you wish to use for the sample values:

<code>PICO_INT8_T</code> ,	8-bit signed integer
<code>PICO_INT16_T</code> ,	16-bit signed integer
<code>PICO_INT32_T</code> ,	32-bit signed integer
<code>PICO_UINT32_T</code> ,	32-bit unsigned integer
<code>PICO_INT64_T</code> ,	64-bit signed integer

`waveform`, the segment index.

`downSampleRatioMode`, the [downsampling](#) mode. See [ps6000aGetValues\(\)](#) for the available modes, but note that a single call to [ps6000aSetDataBuffer\(\)](#) can only associate one buffer with one downsampling mode. If you intend to call [ps6000aGetValues\(\)](#) with more than one downsampling mode activated, then you must call [ps6000aSetDataBuffer\(\)](#) several times to associate a separate buffer with each downsampling mode.

`action`, the method to use when creating the buffer. The buffers are added to a unique list for the channel, data type and segment. Therefore you must use `PICO_CLEAR_ALL` to remove all buffers already written. `PICO_ACTION` values can be ORed together to allow clearing and adding in one call.

Returns

`PICO_OK`
`PICO_INVALID_HANDLE`
`PICO_INVALID_CHANNEL`
`PICO_RATIO_MODE_NOT_SUPPORTED`
`PICO_DRIVER_FUNCTION`
`PICO_INVALID_PARAMETER`

3.43 ps6000aSetDataBuffers - provide locations of both data buffers

```

PICO_STATUS ps6000aSetDataBuffers
(
    int16_t          handle,
    PICO_CHANNEL     channel,
    PICO_POINTER     bufferMax,
    PICO_POINTER     bufferMin,
    int32_t          nSamples,
    PICO_DATA_TYPE   dataType,
    uint64_t         waveform,
    PICO_RATIO_MODE  downSampleRatioMode,
    PICO_ACTION      action
)

```

This function tells the driver the location of one or two buffers for receiving data. You need to allocate memory for the buffers before calling this function. If you do not need two buffers, because you are not using [aggregate](#) mode, then you can optionally use [ps6000aSetDataBuffer\(\)](#) instead.

Applicability

[Block](#) and [streaming](#) modes with [aggregation](#).

Arguments

`handle`, the device identifier returned by [ps6000aOpenUnit\(\)](#).

`channel`, the channel for which you want to set the buffers.

* `bufferMax`, a buffer to receive the maximum data values in aggregation mode, or the non-aggregated values otherwise.

* `bufferMin`, a buffer to receive the minimum aggregated data values. Not used in other downsampling modes.

`nSamples`,
`dataType`,
`waveform`, see [ps6000aSetDataBuffer\(\)](#).

`downSampleRatioMode`, the [downsampling](#) mode. See [ps6000aGetValues\(\)](#) for the available modes, but note that a single call to [ps6000aSetDataBuffer\(\)](#) can only associate one buffer with one downsampling mode. If you intend to call [ps6000aGetValues\(\)](#) with more than one downsampling mode activated, then you must call [ps6000aSetDataBuffer\(\)](#) several times to associate a separate buffer with each downsampling mode.

`action`, see [ps6000aSetDataBuffer\(\)](#)

Returns

PICO_OK
 PICO_INVALID_HANDLE
 PICO_INVALID_CHANNEL
 PICO_RATIO_MODE_NOT_SUPPORTED
 PICO_DRIVER_FUNCTION
 PICO_INVALID_PARAMETER

3.44 ps6000aSetDeviceResolution – set the hardware resolution

```
PICO_STATUS ps6000aSetDeviceResolution
(
    int16_t          handle,
    PICO_DEVICE_RESOLUTION resolution
)
```

This function sets the sampling resolution of the device. At 10-bit and higher resolutions, the maximum capture buffer length is half that of 8-bit mode. When using 12-bit resolution only 2 channels can be enabled to capture data.

When you change the device resolution, the driver discards all previously captured data.

After changing the resolution and before calling [ps6000aRunBlock\(\)](#) or [ps6000aRunStreaming\(\)](#), call [ps6000aSetChannelOn\(\)](#) to set up the input channels.

Applicability

All modes.

Arguments

`handle`, the device identifier returned by [ps6000aOpenUnit\(\)](#).

`resolution`, determines the resolution of the device when opened, the available values are one of the [PICO_DEVICE_RESOLUTION](#).

Returns

PICO_INVALID_DEVICE_RESOLUTION if resolution is out of range.

3.44.1 PICO_DEVICE_RESOLUTION enumerated type

```
typedef enum enPicoDeviceResolution
{
    PICO_DR_8BIT    = 0,
    PICO_DR_12BIT   = 1,
    PICO_DR_10BIT   = 10,
} PICO_DEVICE_RESOLUTION;
```

These values specify the resolution of the sampling hardware in the oscilloscope. Each mode divides the input voltage range into a number of levels as listed below.

Applicability

Calls to [ps6000aSetDeviceResolution\(\)](#) etc.

Values

PICO_DR_8BIT	– 8-bit resolution (256 levels)
PICO_DR_10BIT	– 10-bit resolution (1024 levels)
PICO_DR_12BIT	– 12-bit resolution (4096 levels)

3.45 ps6000aSetDigitalPortOff – switch off digital inputs

```
PICO\_STATUS ps6000aSetDigitalPortOff  
(  
    int16_t                handle,  
    PICO_CHANNEL           port  
)
```

This function switches off one or more digital ports.

Applicability

[Block](#) and [streaming](#) modes with [aggregation](#).

Arguments

handle, the device identifier returned by [ps6000aOpenUnit\(\)](#).

port, see [ps6000aSetDigitalPortOn\(\)](#).

Returns

3.46 ps6000aSetDigitalPortOn – set up and enable digital inputs

```
PICO_STATUS ps6000aSetDigitalPortOn
(
    int16_t          handle,
    PICO_CHANNEL     port,
    int16_t          * logicThresholdLevel,
    int16_t          logicThresholdLevelLength,
    PICO_DIGITAL_PORT_HYSTERESIS hysteresis
)
```

This function switches on one or more digital ports and sets the logic thresholds.

Refer to the data sheet for the fastest sampling rates available with different combinations of analog and digital inputs. In most cases the fastest rates will be obtained by disabling all analog channels. When all analog channels are disabled you must also select 8-bit resolution to allow the digital inputs to operate alone.

Applicability

[Block](#) and [streaming](#) modes with [aggregation](#).

Arguments

`handle`, the device identifier returned by [ps6000aOpenUnit\(\)](#).

`port`, identifies the MSO port:

`PICO_DIGITAL_PORT0` = 128 (**Digital 1** port: digital channels 1D0–1D7)

`PICO_DIGITAL_PORT1` = 129 (**Digital 2** port: digital channels 2D0–2D7)

* `logicThresholdLevel`, on entry, a list of threshold voltages, one for each port pin, used to distinguish the 0 and 1 states. Range: –32 767 (–5 V) to 32 767 (+5 V).

`logicThresholdLevelLength`, the number of items in the `logicThresholdLevel` list.

`hysteresis`, the hysteresis to apply to all channels in the port:

`PICO_VERY_HIGH_400MV`

`PICO_HIGH_200MV`

`PICO_NORMAL_100MV`

`PICO_LOW_50MV`

Returns

3.47 ps6000aSetExternalReferenceInteractionCallback - register callback function for external reference clock events

```
PICO_STATUS ps6000aSetExternalReferenceInteractionCallback  
(  
    int16_t handle,  
    PicoExternalReferenceInteractions callback  
)
```

This function registers your [PicoExternalReferenceInteractions\(\)](#) callback function with the ps6000a driver. Passing a null pointer clears any previous callback.

The PicoScope 6000 (A API) device automatically selects the external reference clock when a signal is applied to the external reference input, and reverts to the internal clock if the signal is removed. The driver will call your callback function whenever the external reference clock status changes.

Applicability

All models

Arguments

`handle`, the device identifier returned by [ps6000aOpenUnit\(\)](#).

`callback`, a pointer to your callback function.

Returns

PICO_OK or a code from `PicoStatus.h`

3.48 ps6000aSetNoOfCaptures - modify rapid block mode

```
PICO_STATUS ps6000aSetNoOfCaptures  
(  
    int16_t    handle,  
    uint64_t   nCaptures  
)
```

This function sets the number of captures to be collected in one run of [rapid block mode](#). If you do not call this function before a run, the driver will capture only one waveform.

Applicability

[Rapid block mode](#)

Arguments

`handle`, the device identifier returned by [ps6000aOpenUnit\(\)](#).

`nCaptures`, the number of waveforms to capture in one run.

Returns

PICO_OK
PICO_INVALID_HANDLE
PICO_INVALID_PARAMETER
PICO_DRIVER_FUNCTION

3.49 ps6000aSetOutputEdgeDetect – change triggering behavior

```
PICO\_STATUS ps6000aSetOutputEdgeDetect  
(  
    int16_t    handle,  
    int16_t    state  
)
```

This function enables or disables output edge detection mode for the logic trigger. Output edge detection is enabled by default and should be left enabled for normal operation.

The oscilloscope normally triggers only when the output of the trigger logic function changes state. For example, if the function is "A high AND B high", the oscilloscope triggers when A is high and B changes from low to high, but does not repeatedly trigger when A and B remain high. Calling [ps6000aSetOutputEdgeDetect\(\)](#) with `state = 0` changes this behavior so that the oscilloscope triggers continually while the logic trigger function evaluates to TRUE.

To find out whether output edge detection is enabled, use [ps6000aQueryOutputEdgeDetect\(\)](#).

Applicability

[Rapid block mode](#)

Arguments

`handle`, the device identifier returned by [ps6000aOpenUnit\(\)](#).

`state`, the desired state of output edge detection:

- 0 = off
- 1 = on

Returns

PICO_OK or other code from `PicoStatus.h`

3.50 ps6000aSetProbeInteractionCallback – register callback function for probe events

```
PICO\_STATUS ps6000aSetProbeInteractionCallback  
(  
    int16_t                handle,  
    PicoProbeInteractions callback  
)
```

This function registers your [PicoProbeInteractions\(\)](#) callback function with the ps6000a driver. The driver will then call your function whenever a Pico intelligent probe is plugged into, or unplugged from, a PicoScope 6000 (A API) device, or if the power consumption of the connected probes exceeds the power available. See [Handling PicoConnect probe interactions](#) for more information on this process.

You should call this function as soon as the device has been successfully opened and before any call to [ps6000aSetChannelOn\(\)](#).

Applicability

All modes

Arguments

`handle`, the device identifier returned by [ps6000aOpenUnit\(\)](#).

`callback`, a pointer to your callback function.

Returns

PICO_OK

3.51 ps6000aSetPulseWidthDigitalPortProperties – set digital port pulse width

```
PICO_STATUS ps6000aSetPulseWidthDigitalPortProperties  
(  
    int16_t                handle,  
    PICO_CHANNEL           port,  
    PICO_DIGITAL_DIRECTION * directions,  
    int16_t                nDirections  
)
```

This function sets the individual digital channels' pulse-width trigger directions. Each trigger direction consists of a channel name and a direction. If the channel is not included in the array of `PICO_DIGITAL_DIRECTION`, the driver assumes the digital channel's pulse-width trigger direction is `PICO_DIGITAL_DONT_CARE`.

Applicability

All modes.
Any model with MSO pod(s) fitted.

Arguments

`handle`, the device identifier returned by [ps6000aOpenUnit\(\)](#).

* `directions`, a pointer to an array of `PICO_DIGITAL_DIRECTION` structures describing the requested properties. The array can contain a single element describing the properties of one channel, or a number of elements describing several digital channels. If `directions` is `NULL`, digital pulse-width triggering is switched off. A digital channel that is not included in the array is set to `PICO_DIGITAL_DONT_CARE`.

`nDirections`, the number of digital channel directions being passed to the driver.

Returns

`PICO_OK` or other code from `PicoStatus.h`

3.52 ps6000aSetPulseWidthQualifierConditions - specify how to combine channels

```
PICO_STATUS ps6000aSetPulseWidthQualifierConditions  
(  
    int16_t          handle,  
    PICO_CONDITION * conditions,  
    int16_t          nConditions,  
    PICO_ACTION      action  
)
```

This function is used to set conditions for the pulse width qualifier, which is an optional input to the triggering condition.

Applicability

All modes

Arguments

`handle`, the device identifier returned by [ps6000aOpenUnit\(\)](#).

* `conditions`, on entry, an array of structures specifying the pulse width qualifier conditions. See [PICO_CONDITION](#).

`nConditions`, the number of structures in the `conditions` array.

`action`, how to combine the array of conditions with existing pulse width qualifier conditions. See [ps6000aSetTriggerChannelConditions\(\)](#) for the list of actions.

Returns

PICO_OK

3.53 ps6000aSetPulseWidthQualifierDirections - specify threshold directions

```
PICO\_STATUS ps6000aSetPulseWidthQualifierDirections  
(  
    int16_t          handle,  
    PICO_DIRECTION * directions,  
    int16_t          nDirections  
)
```

This function is used to set `directions` for the pulse width qualifier, which is an optional input to the triggering condition.

Applicability

All modes

Arguments

`handle`, the device identifier returned by [ps6000aOpenUnit\(\)](#).

* `directions`, an array of structures specifying the pulse width qualifier directions. See [PICO_DIRECTION](#).

`nDirections`, the number of structures in the `directions` array.

Returns

PICO_OK

3.54 ps6000aSetPulseWidthQualifierProperties - specify threshold logic

```
PICO_STATUS ps6000aSetPulseWidthQualifierProperties  
(  
    int16_t          handle,  
    uint32_t        lower,  
    uint32_t        upper,  
    PICO_PULSE_WIDTH_TYPE type  
)
```

This function is used to set parameters for the pulse width qualifier, which is an optional input to the triggering condition.

Applicability

All modes

Arguments

`handle`, the device identifier returned by [ps6000aOpenUnit\(\)](#).

`lower`, the lower pulse width threshold.

`upper`, the upper pulse width threshold.

`type`, the pulse width qualifier type:

PICO_PW_TYPE_NONE = 0, no pulse width qualifier required

PICO_PW_TYPE_LESS_THAN = 1, pulse width must be less than threshold

PICO_PW_TYPE_GREATER_THAN = 2, pulse width must be greater than threshold

PICO_PW_TYPE_IN_RANGE = 3, pulse width must be between two thresholds

PICO_PW_TYPE_OUT_OF_RANGE = 4, pulse width must not be between two thresholds

Returns

PICO_OK

3.55 ps6000aSetSimpleTrigger - set up triggering

```

PICO\_STATUS ps6000aSetSimpleTrigger
(
    int16_t          handle,
    int16_t          enable,
    PICO\_CHANNEL    source,
    int16_t          threshold,
    PICO\_THRESHOLD\_DIRECTION direction,
    uint64_t         delay,
    uint32_t         autoTriggerMicroSeconds
)

```

This function simplifies arming the trigger. It supports only the LEVEL trigger types and does not allow more than one channel to have a trigger applied to it. Any previous pulse width qualifier is canceled.

Applicability

All modes

Arguments

`handle`, the device identifier returned by [ps6000aOpenUnit\(\)](#).

`enable`: disable (0) or enable (1) the trigger.

`source`: the channel on which to trigger. This can be any of the input channels listed under [ps6000aSetChannelOn\(\)](#).

`threshold`: the [ADC count](#) at which the trigger will fire.

`direction`: the direction in which the signal must move to cause a trigger. The following directions are supported: ABOVE, BELOW, RISING, FALLING and RISING_OR_FALLING.

`delay`: the time between the trigger occurring and the first sample being taken.

`autoTriggerMicroSeconds`: the number of microseconds the device will wait if no trigger occurs.

Returns

PICO_OK
PICO_INVALID_HANDLE
PICO_USER_CALLBACK
PICO_DRIVER_FUNCTION

3.56 ps6000aSetTriggerChannelConditions - set triggering logic

```
PICO_STATUS ps6000aSetTriggerChannelConditions
(
    int16_t          handle,
    PICO_CONDITION * conditions,
    int16_t          nConditions,
    PICO_ACTION      action
)
```

This function sets up trigger conditions on the scope's inputs. The trigger is defined by one or more [PICO_CONDITION](#) structures that are then ORed together. Each structure is itself the AND of the states of one or more of the inputs. This AND-OR logic allows you to create any possible Boolean function of the scope's inputs.

If complex triggering is not required, use [ps6000aSetSimpleTrigger\(\)](#).

Applicability

All modes

Arguments

`handle`, the device identifier returned by [ps6000aOpenUnit\(\)](#).

`conditions`, an array of [PICO_CONDITION](#) structures specifying the conditions that should be applied to each channel. In the simplest case, the array consists of a single element. When there is more than one element, the overall trigger condition is the logical OR of all the elements.

`nConditions`, the number of elements in the `conditions` array. If `nConditions` is zero then triggering is switched off.

`action`, specifies how to apply the `PICO_CONDITION` array to any existing trigger conditions:

```
PICO_CLEAR_ALL = 0x00000001
PICO_ADD       = 0x00000002
```

Returns

```
PICO_OK
PICO_INVALID_HANDLE
PICO_USER_CALLBACK
PICO_CONDITIONS
PICO_MEMORY_FAIL
PICO_DRIVER_FUNCTION
```

3.56.1 PICO_CONDITION structure

A structure of this type is passed to [ps6000aSetTriggerChannelConditions\(\)](#) in the conditions argument to specify the trigger conditions, and is defined as follows:

```
typedef struct tPicoCondition
{
    PICO_CHANNEL      source;
    PICO_TRIGGER_STATE condition;
} PICO_CONDITION
```

Each structure is the logical AND of the states of the scope's inputs. The [ps6000aSetTriggerChannelConditions\(\)](#) function can OR together a number of these structures to produce the final trigger condition, which can be any possible Boolean function of the scope's inputs.

The structure is byte-aligned. In C++, for example, you should specify this using the `#pragma pack()` instruction.

Elements

`source`, the signal that forms an input to the trigger condition:

- PICO_CHANNEL_A, PICO_CHANNEL_B, PICO_CHANNEL_C, PICO_CHANNEL_D, PICO_CHANNEL_E, PICO_CHANNEL_F, PICO_CHANNEL_G, PICO_CHANNEL_H, one of the analog input channels
- PICO_PORT0, MSO port **Digital 1** (channels 1D0–1D7)
- PICO_PORT1, MSO port **Digital 2** (channels 2D0–2D7)
- PICO_TRIGGER_AUX, the **AUX** input
- PICO_PULSE_WIDTH_SOURCE, the output of the pulse width qualifier

`condition`, the type of condition that should be applied to each channel. Use these constants:

- [PICO_CONDITION_DONT_CARE](#)
- [PICO_CONDITION_TRUE](#)
- [PICO_CONDITION_FALSE](#)

The channels that are set to [PICO_CONDITION_TRUE](#) or [PICO_CONDITION_FALSE](#) must all meet their conditions simultaneously to produce a trigger. Channels set to [PICO_CONDITION_DONT_CARE](#) are ignored.

3.57 ps6000aSetTriggerChannelDirections - set trigger directions

```
PICO\_STATUS ps6000aSetTriggerChannelDirections  
(  
    int16_t          handle,  
    PICO_DIRECTION  * directions,  
    int16_t          nDirections  
)
```

This function sets the direction of the trigger for one or more channels.

Applicability

All modes

Arguments

`handle`, the device identifier returned by [ps6000aOpenUnit\(\)](#).

* `directions`, an array of structures specifying the trigger direction for each channel. See [PICO_DIRECTION](#).

`nDirections`, the number of structures in the `directions` array.

Returns

PICO_OK
PICO_INVALID_HANDLE
PICO_USER_CALLBACK
PICO_INVALID_PARAMETER

3.57.1 PICO_DIRECTION structure

A structure of this type is passed to [ps6000aSetTriggerChannelDirections\(\)](#) in the `directions` argument to specify the trigger directions, and is defined as follows:

```
typedef struct tPicoDirection
{
    PICO_CHANNEL          channel;
    PICO_THRESHOLD_DIRECTION direction;
    PICO_THRESHOLD_MODE   thresholdMode;
} PICO_DIRECTION
```

The structure is byte-aligned. In C++, for example, you should specify this using the `#pragma pack()` instruction.

Elements

`channel`, the channel whose direction you want to set.

`direction`, the direction required for the channel.

`thresholdMode`, the type of threshold to use.

PICO_THRESHOLD_DIRECTION values:

Constant	Trigger type	Threshold	Polarity
PICO_ABOVE = 0	Gated	Upper	Above
PICO_ABOVE_LOWER = 5	Gated	Lower	Above
PICO_BELOW = 1	Gated	Upper	Below
PICO_BELOW_LOWER = 6	Gated	Lower	Below
PICO_RISING = 2	Threshold	Upper	Rising
PICO_RISING_LOWER = 7	Threshold	Lower	Rising
PICO_FALLING = 3	Threshold	Upper	Falling
PICO_FALLING_LOWER = 8	Threshold	Lower	Falling
PICO_RISING_OR_FALLING = 4	Threshold	Lower (for rising edge) Upper (for falling edge)	
PICO_INSIDE = 0	Window-qualified	Both	Inside
PICO_OUTSIDE = 1	Window-qualified	Both	Outside
PICO_ENTER = 2	Window	Both	Entering
PICO_EXIT = 3	Window	Both	Leaving
PICO_ENTER_OR_EXIT = 4	Window	Both	Either entering or leaving
PICO_POSITIVE_RUNT = 9	Window-qualified	Both	Entering from below
PICO_NEGATIVE_RUNT	Window-qualified	Both	Entering from above
PICO_LOGIC_LOWER = 1000	Logic	Lower	
PICO_LOGIC_UPPER = 1001	Logic	Upper	
PICO_NONE = 2	None	None	None

PICO_THRESHOLD_MODE values:

Constant	Mode
PICO_LEVEL = 0	Active when input is above or below a single threshold
PICO_WINDOW = 1	Active when input is between two thresholds

3.58 ps6000aSetTriggerChannelProperties - set up triggering

```
PICO_STATUS ps6000aSetTriggerChannelProperties
(
    int16_t                handle,
    PICO_TRIGGER_CHANNEL_PROPERTIES * channelProperties
    int16_t                nChannelProperties
    int16_t                auxOutputEnable,
    uint32_t               autoTriggerMicroSeconds
)
```

This function is used to enable or disable triggering and set its parameters.

Applicability

All modes

Arguments

`handle`, the device identifier returned by [ps6000aOpenUnit\(\)](#).

`channelProperties`, a pointer to an array of [TRIGGER_CHANNEL_PROPERTIES](#) structures describing the requested properties. The array can contain a single element describing the properties of one channel, or a number of elements describing several channels. If `NULL` is passed, triggering is switched off.

`nChannelProperties`, the size of the `channelProperties` array. If zero, triggering is switched off.

`auxOutputEnable`: not used

`autoTriggerMicroSeconds`, the time in microseconds for which the scope device will wait before collecting data if no trigger event occurs. If this is set to zero, the scope device will wait indefinitely for a trigger.

Returns

PICO_OK
PICO_INVALID_HANDLE
PICO_USER_CALLBACK
PICO_TRIGGER_ERROR
PICO_MEMORY_FAIL
PICO_INVALID_TRIGGER_PROPERTY
PICO_DRIVER_FUNCTION
PICO_INVALID_PARAMETER

3.58.1 TRIGGER_CHANNEL_PROPERTIES structure

A structure of this type is passed to [ps6000aSetTriggerChannelProperties\(\)](#) in the `channelProperties` argument to specify the trigger mechanism, and is defined as follows:

```
typedef struct tTriggerChannelProperties
{
    int16_t      thresholdUpper;
    uint16_t     thresholdUpperHysteresis;
    int16_t      thresholdLower;
    uint16_t     thresholdLowerHysteresis;
    PICO_CHANNEL channel;
} PICO_TRIGGER_CHANNEL_PROPERTIES
```

The structure is byte-aligned. In C++, for example, you should specify this using the `#pragma pack()` instruction.

There are two trigger thresholds called `Upper` and `Lower`. Each trigger type uses one or other of these thresholds, or both, as specified in [ps6000aSetTriggerChannelDirections\(\)](#). Each trigger threshold has its own hysteresis setting.

Elements

`thresholdUpper`, the upper threshold at which the trigger fires. It is scaled in 16-bit [ADC counts](#) at the currently selected range for that channel. Use when "Upper" or "Both" is specified in [ps6000aSetTriggerChannelDirections\(\)](#).

`hysteresisUpper`, the distance by which the signal must fall below the upper threshold (for rising edge triggers) or rise above the upper threshold (for falling edge triggers) in order to rearm the trigger for the next event. It is scaled in 16-bit counts.

`thresholdLower`, lower threshold (see `thresholdUpper`). Use when "Lower" or "Both" is specified in [ps6000aSetTriggerChannelDirections\(\)](#).

`hysteresisLower`, lower threshold hysteresis (see `hysteresisUpper`).

`channel`, the channel to which the properties apply. This can be one of the input channels listed under [ps6000aSetChannelOn\(\)](#).

3.59 ps6000aSetTriggerDelay - set post-trigger delay

```
PICO\_STATUS ps6000aSetTriggerDelay  
(  
    int16_t    handle,  
    uint64_t   delay  
)
```

This function sets the post-trigger delay, which causes capture to start a defined time after the trigger event.

Applicability

[Block](#) and [rapid block](#) modes

Arguments

`handle`, the device identifier returned by [ps6000aOpenUnit\(\)](#).

`delay`, the time between the trigger occurring and the first sample. For example, if `delay=100`, the scope would wait 100 sample periods before sampling. At a [timebase](#) of 5 GS/s, or 200 ps per sample (`timebase=0`), the total delay would then be $100 \times 200 \text{ ps} = 20 \text{ ns}$.

Range: 0 to [MAX_DELAY_COUNT](#).

Returns

PICO_OK
PICO_INVALID_HANDLE
PICO_USER_CALLBACK
PICO_DRIVER_FUNCTION

3.60 ps6000aSetTriggerDigitalPortProperties - set port directions

```
PICO_STATUS ps6000aSetTriggerDigitalPortProperties
(
    int16_t                handle,
    PICO_CHANNEL           port,
    PICO_DIGITAL_CHANNEL_DIRECTIONS * directions,
    int16_t                nDirections
)
```

This function is used to enable or disable triggering and set its parameters.

Applicability

All modes

Arguments

`handle`, the device identifier returned by [ps6000aOpenUnit\(\)](#).

`port`, identifies the digital port on the oscilloscope:

PICO_PORT0: **Digital 1** port (channels 1D0–1D7)

PICO_PORT1: **Digital 2** port (channels 2D0–2D7)

* `directions`, an array of structures specifying the channel directions.

`nDirections`, the number of items in the `directions` array.

Returns

PICO_OK

3.60.1 PICO_DIGITAL_CHANNEL DIRECTIONS structure

A list of structures of this type is passed to [ps6000aSetTriggerDigitalPortProperties\(\)](#) in the `directions` argument to specify the digital channel trigger directions, and is defined as follows:

```
typedef struct tDigitalChannelDirections
{
    PICO_PORT_DIGITAL_CHANNEL    channel;
    PICO_DIGITAL_DIRECTION       direction;
} PICO_DIGITAL_CHANNEL DIRECTIONS
```

The structure is byte-aligned. In C++, for example, you should specify this using the `#pragma pack()` instruction.

Elements

`channel`, identifies the digital channel from `PICO_PORT_DIGITAL_CHANNEL0` up to `PICO_PORT_DIGITAL_CHANNEL7`.

`direction`, the trigger direction from the following list:

<code>PICO_DIGITAL_DONT_CARE :</code>	channel has no effect on trigger
<code>PICO_DIGITAL_DIRECTION_LOW :</code>	channel must be low to trigger
<code>PICO_DIGITAL_DIRECTION_HIGH :</code>	channel must be high to trigger
<code>PICO_DIGITAL_DIRECTION_RISING :</code>	channel must transition from low to high to trigger
<code>PICO_DIGITAL_DIRECTION_FALLING :</code>	channel must transition from high to low to trigger
<code>PICO_DIGITAL_DIRECTION_RISING_OR_FALLING :</code>	any transition on channel causes a trigger

3.61 ps6000aSigGenApply - set output parameters

```
PICO\_STATUS ps6000aSigGenApply
(
    int16_t          handle,
    int16_t          sigGenEnabled,
    int16_t          sweepEnabled,
    int16_t          triggerEnabled,
    int16_t          automaticClockOptimisationEnabled,
    int16_t          overrideAutomaticClockAndPrescale,
    double           * frequency,
    double           * stopFrequency,
    double           * frequencyIncrement,
    double           * dwellTime
)
```

This function sets the signal generator running using parameters previously configured by the other ps6000aSigGen... functions.

Applicability

All modes

Arguments

`handle`, the device identifier returned by [ps6000aOpenUnit\(\)](#).

`sigGenEnabled`, switches the signal generator on (1) or off (0).

`sweepEnabled`, switches sweep mode on (1) or off (0).

`triggerEnabled`, switches triggering on (1) or off (0).

`automaticClockOptimisationEnabled`, switches clock optimization on (1) or off (0).

In automatic clock optimization mode, the DAC clock and prescaler are automatically adjusted by the driver to generate the user-requested output frequency as precisely as possible. This is recommended for most applications. When automatic clock optimization is turned off, the DAC clock remains fixed at its maximum frequency (or a user-specified frequency if using `overrideAutomaticClockAndPrescale`).

`overrideAutomaticClockAndPrescale`, switches automatic clock and prescale override on or off:

0 = override off: ignore parameters set by [ps6000aSigGenClockManual\(\)](#) and allow the driver to choose the DAC clock and prescaler. This mode is recommended for most applications.

1 = override on: use parameters set by [ps6000aSigGenClockManual\(\)](#) to manually specify a user-defined DAC clock frequency and prescaler.

* `frequency`, on exit, the actual achieved signal generator frequency (or start frequency in sweep mode).

* `stopFrequency`, on exit, the actual achieved signal generator frequency at the end of the sweep.

* `frequencyIncrement`, on exit, the actual achieved frequency step size in sweep mode.

* `dwellTime`, on exit, the actual achieved time in seconds between frequency steps in sweep mode.

Returns

PICO_OK
PICO_INVALID_HANDLE
PICO_DRIVER_FUNCTION
PICO_NOT_RESPONDING

3.62 ps6000aSigGenClockManual - control signal generator clock

```
PICO_STATUS ps6000aSigGenClockManual  
(  
    int16_t                handle,  
    double                 dacClockFrequency,  
    uint64_t               prescaleRatio  
)
```

This function allows direct control of the signal generator clock.

Applicability

All modes

Arguments

`handle`, the device identifier returned by [ps6000aOpenUnit\(\)](#).

`dacClockFrequency`, the clock frequency of the DAC (digital-to-analog converter) in hertz.
Range: 100e6 to 200e6

`prescaleRatio`, the ratio to program into the prescaler. The prescaler allows the precise generation of low frequencies:

$\text{Sample frequency} = \text{dacClockFrequency} / \text{prescaleRatio}$

Range: 1 to 16384

Returns

PICO_OK
PICO_INVALID_HANDLE
PICO_DRIVER_FUNCTION
PICO_NOT_RESPONDING
PICO_SIGGEN_FREQUENCY_OUT_OF_RANGE
PICO_SIGGEN_PRESCALE_OUT_OF_RANGE

3.63 ps6000aSigGenFilter - switch output filter on or off

```
PICO\_STATUS ps6000aSigGenFilter  
(  
    int16_t          handle,  
    PICO_SIGGEN_FILTER_STATE filterState  
)
```

This function controls the filter on the output of the signal generator. The filter can be used to remove unwanted high-frequency synthesizer noise.

Applicability

All modes

Arguments

`handle`, the device identifier returned by [ps6000aOpenUnit\(\)](#).

`filterState`, can be set on or off, or put in automatic mode.

Returns

PICO_OK
PICO_INVALID_HANDLE
PICO_DRIVER_FUNCTION
PICO_NOT_RESPONDING

3.64 ps6000aSigGenFrequency - set output frequency

```
PICO\_STATUS ps6000aSigGenFrequency  
(  
    int16_t          handle,  
    double          frequencyHz  
)
```

This function sets the frequency of the signal generator.

Applicability

All modes

Arguments

`handle`, the device identifier returned by [ps6000aOpenUnit\(\)](#).

`frequencyHz`, the desired frequency in hertz.

Returns

PICO_OK or a code from `PicoStatus.h`

3.65 ps6000aSigGenFrequencyLimits - get limits in sweep mode

```
PICO_STATUS ps6000aSigGenFrequencyLimits
(
    int16_t                handle,
    PICO_WAVE_TYPE        waveType,
    uint64_t               * numSamples,
    double                 * startFrequency,
    int16_t                sweepEnabled,
    double                 * manualDacClockFrequency,
    uint64_t               * manualPrescaleRatio,
    double                 * maxStopFrequencyOut,
    double                 * minFrequencyStepOut,
    double                 * maxFrequencyStepOut,
    double                 * minDwellTimeOut,
    double                 * maxDwellTimeOut
)
```

This function queries the maximum and minimum values for the signal generator in frequency sweep mode.

Applicability

All models

Arguments

`handle`, the device identifier returned by [ps6000aOpenUnit\(\)](#).

`waveType`, the waveform that you intend to use.

* `numSamples`, for arbitrary waveforms only, the number of samples in the AWG buffer.

* `startFrequency`, for fixed-frequency mode, the desired frequency; for frequency sweep mode, the desired start frequency.

`sweepEnabled`, whether sweep mode is required (1) or not required (0).

* `manualDacClockFrequency` and * `manualPrescaleRatio`, if using manual signal generator clock parameters, provide the clock frequency and prescaler you intend to set using [ps6000aSigGenClockManual\(\)](#). If not using manual clock parameters, set both to null.

* `maxStopFrequencyOut`, on exit, the highest possible stop frequency for frequency sweep mode.

* `minFrequencyStepOut`, on exit, the smallest possible frequency step for frequency sweep mode.

* `maxFrequencyStepOut`, on exit, the largest possible frequency step for frequency sweep mode.

* `minDwellTimeOut`, on exit, the smallest possible dwell time for frequency sweep mode.

* `maxDwellTimeOut`, on exit, the largest possible dwell time for frequency sweep mode.

Returns

PICO_OK

3.66 ps6000aSigGenFrequencySweep - set signal generator to frequency sweep mode

```
PICO_STATUS ps6000aSigGenFrequencySweep
(
    int16_t                handle,
    double                 stopFrequencyHz,
    double                 frequencyIncrement,
    double                 dwellTimeSeconds,
    PICO_SWEEP_TYPE       sweepType
)
```

This function sets frequency sweep parameters for the signal generator. It assumes that you have previously called [ps6000aSigGenFrequency\(\)](#) to set the start frequency.

Applicability

Signal generator.

Arguments

`handle`, the device identifier returned by [ps6000aOpenUnit\(\)](#).

`stopFrequencyHz`, the frequency in hertz at which the sweep should stop.

`frequencyIncrement`, the amount by which the frequency should change, in hertz, at each step of the sweep.

`dwellTimeSeconds`, the time for which the generator should wait between frequency steps.

`sweepType`, the direction of the sweep, from the following list:

`PICO_UP` = 0, to sweep from `startFrequency` up to `stopFrequency` and then repeat.

`PICO_DOWN` = 1, to sweep from `startFrequency` down to `stopFrequency` and then repeat.

`PICO_UPDOWN` = 2, to sweep from `startFrequency` up to `stopFrequency`, then down to `startFrequency`, and then repeat.

`PICO_DOWNUP` = 3, to sweep from `startFrequency` down to `stopFrequency`, then up to `startFrequency`, and then repeat.

Returns

`PICO_OK` or a code from `PicoStatus.h`

3.67 ps6000aSigGenLimits - get signal generator parameters

```
PICO_STATUS ps6000aSigGenLimits
(
    int16_t          handle,
    PICO_SIGGEN_PARAMETER parameter,
    double           * minimumPermissibleValue,
    double           * maximumPermissibleValue,
    double           * step
)
```

This function queries the maximum and minimum allowable values for a given signal generator parameter.

Applicability

All models

Arguments

`handle`, the device identifier returned by [ps6000aOpenUnit\(\)](#).

`parameter`, one of the following enumerated values:

```
PICO_SIGGEN_PARAM_OUTPUT_VOLTS = 0, the signal generator output voltage
PICO_SIGGEN_PARAM_SAMPLE       = 1, the value of a sample in the arbitrary waveform
buffer
PICO_SIGGEN_PARAM_BUFFER_LENGTH = 2, the length of the arbitrary waveform buffer ,in
samples
```

* `minimumPermissibleValue`, on exit, the minimum value

* `maximumPermissibleValue`, on exit, the maximum value

* `step`, on exit, the smallest increment in the parameter that will cause a change in the signal generator output.

Returns

PICO_OK

3.68 ps6000aSigGenPause - stop the signal generator

```
PICO\_STATUS ps6000aSigGenPause  
(  
    int16_t          handle  
)
```

This function stops the signal generator. The output will remain at a constant voltage until the generator is restarted with [ps6000aSigGenRestart\(\)](#).

Applicability

All modes

Arguments

handle, the device identifier returned by [ps6000aOpenUnit\(\)](#).

Returns

PICO_OK or a code from PicoStatus.h

3.69 ps6000aSigGenPhase - set signal generator using delta-phase

```
PICO_STATUS ps6000aSigGenPhase
(
    int16_t          handle,
    uint64_t        deltaPhase
)
```

This function sets the signal generator output frequency (or the starting frequency, in the case of a frequency sweep) using a delta-phase value instead of a frequency. See [Calculating deltaPhase](#) for more information on how to calculate this value.

Applicability

All modes

Arguments

`handle`, the device identifier returned by [ps6000aOpenUnit\(\)](#).

`deltaPhase`, the desired delta phase.

Returns

PICO_OK
PICO_INVALID_HANDLE
PICO_DRIVER_FUNCTION
PICO_SIGGEN_FREQUENCY_OUT_OF_RANGE

3.69.1 Calculating deltaPhase

The signal generator uses direct digital synthesis (DDS) with a 32-bit phase accumulator that indicates the present location in the waveform. The top bits of the phase accumulator are used as an index into a buffer containing the arbitrary waveform. The remaining bits act as the fractional part of the index, enabling high-resolution control of output frequency and allowing the generation of lower frequencies.

The signal generator steps through the waveform by adding a *deltaPhase* value between 1 and *phaseAccumulatorSize*-1 to the phase accumulator every *dacPeriod* (= 1/*dacFrequency*). The generator produces a waveform at a frequency that can be calculated as follows:

$$outputFrequency = \frac{dacFrequency}{arbitraryWaveformSize} \times \frac{deltaPhase}{2^{(phaseAccumulatorSize - bufferAddressWidth)}}$$

where:

<i>outputFrequency</i>	= repetition rate of the complete arbitrary waveform
<i>dacFrequency</i>	= update rate of AWG DAC (see table below)
<i>deltaPhase</i>	= delta-phase value supplied to this function
<i>phaseAccumulatorSize</i>	= width in bits of phase accumulator (see table below)
<i>bufferAddressWidth</i>	= width in bits of AWG buffer address (see table below)
<i>arbitraryWaveformSize</i>	= length in samples of the user-defined waveform

Parameter	Value
<i>dacFrequency</i>	Default: 200 MHz. Can be changed by ps6000aSigGenClockManual()
<i>dacPeriod</i>	$1/dacFrequency$. Default: 5 ns.
<i>phaseAccumulatorSize</i>	32
<i>bufferAddressWidth</i>	16

3.70 ps6000aSigGenPhaseSweep - set signal generator to sweep using delta-phase

```
PICO_STATUS ps6000aSigGenPhaseSweep
(
    int16_t          handle,
    uint64_t         stopDeltaPhase,
    uint64_t         deltaPhaseIncrement,
    uint64_t         dwellCount,
    PICO_SWEEP_TYPE sweepType
)
```

This function sets frequency sweep parameters for the signal generator using delta-phase values instead of frequency values. It assumes that you have previously called [ps6000aSigGenPhase\(\)](#) to set the starting delta-phase.

Applicability

All modes

Arguments

`handle`, the device identifier returned by [ps6000aOpenUnit\(\)](#).

`stopDeltaPhase`, the delta-phase at which the sweep should stop. You must set the starting delta-phase, `deltaPhase`, beforehand by calling [ps6000aSigGenPhase\(\)](#).

`deltaPhaseIncrement`, the amount by which the delta-phase should change at each step of the sweep.

`dwellCount`, the number of samples for which the generator should wait between sweep steps.

`sweepType`, the direction of the sweep, from the following list:

`PICO_UP` = 0, to sweep from `deltaPhase` up to `stopDeltaPhase` and then repeat.

`PICO_DOWN` = 1, to sweep from `deltaPhase` down to `stopDeltaPhase` and then repeat.

`PICO_UPDOWN` = 2, to sweep from `deltaPhase` up to `stopDeltaPhase`, then down to `deltaPhase`, and then repeat.

`PICO_DOWNUP` = 3, to sweep from `deltaPhase` down to `stopDeltaPhase`, then up to `deltaPhase`, and then repeat.

Returns

`PICO_OK` or a code from `PicoStatus.h`

3.71 ps6000aSigGenRange - set signal generator output voltages

```
PICO_STATUS ps6000aSigGenRange  
(  
    int16_t    handle,  
    double    peakToPeakVolts,  
    double    offsetVolts  
)
```

This function sets the amplitude (peak to peak measurement) and offset (voltage corresponding to data value of zero) of the signal generator.

Applicability

All modes

Arguments

`handle`, the device identifier returned by [ps6000aOpenUnit\(\)](#).

`peakToPeakVolts`, the signal generator's peak-to-peak output range in volts.

`offsetVolts`, the signal generator's output offset in volts.

Returns

PICO_OK

PICO_INVALID_HANDLE

PICO_DRIVER_FUNCTION

PICO_NOT_RESPONDING

PICO_SIGGEN_PK_TO_PK

PICO_SIGGEN_OFFSET_VOLTAGE

PICO_SIGGEN_OUTPUT_OVER_VOLTAGE (if `peakToPeak` and `offset` are within their individual ranges but the combination is out of range)

3.72 ps6000aSigGenRestart - continue after pause

```
PICO\_STATUS ps6000aSigGenRestart  
(  
    int16_t          handle  
)
```

This function restarts the signal generator after it was paused with [ps6000aSigGenPause\(\)](#).

Applicability

All modes

Arguments

handle, the device identifier returned by [ps6000aOpenUnit\(\)](#).

Returns

PICO_OK or a code from `PicoStatus.h`

3.73 ps6000aSigGenSoftwareTriggerControl - set software triggering

```
PICO\_STATUS ps6000aSigGenSoftwareTriggerControl  
(  
    int16_t                handle,  
    PICO_SIGGEN_TRIG_TYPE  triggerState  
)
```

This function sets the trigger type (edge or level) and polarity for software triggering of the signal generator.

Applicability

All modes

Arguments

`handle`, the device identifier returned by [ps6000aOpenUnit\(\)](#).

```
triggerState,  
    PICO_SIGGEN_RISING = 0,    rising edge trigger  
    PICO_SIGGEN_FALLING = 1,   falling edge trigger  
    PICO_SIGGEN_GATE_HIGH = 2, trigger when high  
    PICO_SIGGEN_GATE_LOW = 3,  trigger when low
```

Returns

```
PICO_OK  
PICO_INVALID_HANDLE  
PICO_SIGGEN_TRIGGER_SOURCE  
PICO_DRIVER_FUNCTION  
PICO_NOT_RESPONDING
```

3.74 ps6000aSigGenTrigger - choose the trigger event

```
PICO\_STATUS ps6000aSigGenTrigger  
(  
    int16_t          handle,  
    PICO_SIGGEN_TRIG_TYPE triggerType,  
    PICO_SIGGEN_TRIG_SOURCE triggerSource,  
    uint64_t         cycles,  
    uint64_t         autoTriggerPicoSeconds  
)
```

This function sets up triggering for the signal generator. This feature causes the signal generator to start and stop under the control of a signal or event.

Applicability

All modes

Arguments

`handle`, the device identifier returned by [ps6000aOpenUnit\(\)](#).

`triggerType`, whether an edge trigger (starts on a specified edge) or a gated trigger (runs while trigger is in the specified state).

`triggerSource`, the signal used as a trigger.

`cycles`, the number of waveform cycles to generate after the trigger edge or after entering the active trigger state. Set to zero to make the signal generator run indefinitely.

`autoTriggerPicoSeconds`, the length of time in picoseconds (ps) to wait for a trigger before starting the signal generator. Set to zero to make the signal generator wait indefinitely for a trigger.

Returns

PICO_OK
PICO_INVALID_HANDLE
PICO_SIGGEN_TRIGGER_SOURCE
PICO_DRIVER_FUNCTION
PICO_NOT_RESPONDING

3.75 ps6000aSigGenWaveform - choose signal generator waveform

```
PICO_STATUS ps6000aSigGenWaveform  
(  
    int16_t          handle,  
    PICO_WAVE_TYPE  waveType,  
    int16_t          * buffer,  
    uint64_t        bufferLength  
)
```

This function specifies which waveform the signal generator will produce.

Applicability

All modes

Arguments

`handle`, the device identifier returned by [ps6000aOpenUnit\(\)](#).

`waveType`, specifies the type of waveform to generate.

* `buffer`, an array of sample values to be used by the arbitrary waveform generator (AWG). Used only when `waveType = PICO_ARBITRARY`.

`bufferLength`, the number of samples in the buffer array. Used only when `waveType = PICO_ARBITRARY`.

Returns

PICO_OK
PICO_INVALID_HANDLE
PICO_SIGGEN_TRIGGER_SOURCE
PICO_DRIVER_FUNCTION
PICO_NOT_RESPONDING

3.76 ps6000aSigGenWaveformDutyCycle - set duty cycle

```
PICO_STATUS ps6000aSigGenWaveformDutyCycle  
(  
    int16_t    handle,  
    double     dutyCyclePercent  
)
```

This function sets the duty cycle of the signal generator waveform in square wave and triangle wave modes.

The duty cycle of a pulse waveform is defined as the time spent in the high state divided by the period. Set to 50% to obtain a square wave.

Applicability

Square wave and triangle wave outputs only.

Arguments

`handle`, the device identifier returned by [ps6000aOpenUnit\(\)](#).

`dutyCyclePercent`, the percentage duty cycle of the waveform from 0.0 to 100.0.

Returns

PICO_OK
PICO_INVALID_HANDLE
PICO_SIGGEN_TRIGGER_SOURCE
PICO_DRIVER_FUNCTION
PICO_NOT_RESPONDING

3.77 ps6000aStartFirmwareUpdate - update the device firmware

```
PICO\_STATUS ps6000aStartFirmwareUpdate  
(  
    int16_t                handle,  
    PicoUpdateFirmwareProgress progress  
)
```

This function updates the device's firmware (the embedded instructions stored in nonvolatile memory in the device). Updates may fix bugs or add new features.

Applicability

All modes

Arguments

`handle`, the device identifier returned by [ps6000aOpenUnit\(\)](#).

`progress`, a user-supplied function that receives callbacks when the status of the update changes. See [PicoUpdateFirmwareProgress\(\)](#). May be NULL if not required.

Returns

`PICO_FIRMWARE_UP_TO_DATE` - the firmware update was performed successfully or firmware was already up to date

`PICO_INVALID_HANDLE` - invalid handle parameter

`PICO_DRIVER_FUNCTION` - another driver call is in progress

3.78 ps6000aStop - stop sampling

```
PICO\_STATUS ps6000aStop  
(  
    int16_t    handle  
)
```

This function stops the scope device from sampling data.

When running the device in [streaming mode](#), always call this function after the end of a capture to ensure that the scope is ready for the next capture.

When running the device in [block mode](#) or [rapid block mode](#), you can call this function to interrupt data capture.

If this function is called before a trigger event occurs, the oscilloscope may not contain valid data.

Applicability

All modes

Arguments

handle, the device identifier returned by [ps6000aOpenUnit\(\)](#).

Returns

PICO_OK
PICO_INVALID_HANDLE
PICO_USER_CALLBACK
PICO_DRIVER_FUNCTION

3.79 ps6000aStopUsingGetValuesOverlapped - complements ps6000aGetValuesOverlapped

```
PICO\_STATUS ps6000aStopUsingGetValuesOverlapped  
(  
    int16_t          handle  
)
```

This function stops deferred data-collection that was started by calling [ps6000aGetValuesOverlapped\(\)](#).

Applicability

Rapid block mode

Arguments

`handle`, the device identifier returned by [ps6000aOpenUnit\(\)](#).

Returns

PICO_OK
PICO_INVALID_HANDLE
PICO_DRIVER_FUNCTION
PICO_FIRMWARE_UPDATE_REQUIRED_TO_USE_DEVICE_WITH_THIS_DRIVER

3.80 ps6000aTriggerWithinPreTriggerSamples - switch feature on or off

```
PICO_STATUS ps6000aTriggerWithinPreTriggerSamples  
(  
    int16_t                handle,  
    PICO_TRIGGER_WITHIN_PRE_TRIGGER state  
)
```

This function controls a special triggering feature.

Applicability

All modes

Arguments

`handle`, the device identifier returned by [ps6000aOpenUnit\(\)](#).

`state`, 0 to enable, 1 to disable.

Returns

PICO_OK
PICO_INVALID_HANDLE
PICO_USER_CALLBACK
PICO_DRIVER_FUNCTION

4 Callbacks

4.1 ps6000aBlockReady - indicate when block-mode data ready

```
typedef void (CALLBACK *ps6000aBlockReady)
(
    int16_t      handle,
    PICO_STATUS  status,
    PICO_POINTER pParameter
)
```

This [callback](#) function is part of your application. You register it with the PicoScope 6000E Series driver using [ps6000aRunBlock\(\)](#) and the driver calls it back when block-mode data is ready. You can then download the data using the [ps6000aGetValues\(\)](#) function.

Applicability

[Block mode](#) only

Arguments

`handle`, the device identifier returned by [ps6000aOpenUnit\(\)](#).

`status`, indicates whether an error occurred during collection of the data.

`pParameter`, a pointer passed from [ps6000aRunBlock\(\)](#). Your callback function can write to this location to send any data, such as a status flag, back to your application.

Returns

nothing

4.2 ps6000aDataReady - indicate when post-collection data ready

```
typedef void *ps6000aDataReady
(
    int16_t          handle,
    PICO\_STATUS     status,
    uint64_t         noOfSamples,
    int16_t          overflow,
    PICO_POINTER     pParameter
)
```

This is a [callback](#) function that you write to collect data from the driver. You supply a pointer to the function when you call [ps6000aGetValuesAsync\(\)](#) and the driver calls your function back when the data is ready.

Applicability

All modes

Arguments

`handle`, the device identifier returned by [ps6000aOpenUnit\(\)](#).

`status`, a `PICO_STATUS` code returned by the driver.

`noOfSamples`, the number of samples collected.

`overflow`, a set of flags that indicates whether an overvoltage has occurred and on which channels. It is a bit field with bit 0 representing Channel A.

`pParameter`, a void pointer passed from [ps6000aGetValuesAsync\(\)](#). The callback function can write to this location to send any data, such as a status flag, back to the application. The data type is defined by the application programmer.

Returns

nothing

4.3 PicoUpdateFirmwareProgress - get status of firmware update

```
typedef void (CALLBACK * PicoUpdateFirmwareProgress)
(
    int16_t      handle,
    uint16_t     progress
)
```

You should write this [callback](#) function and register it with the driver using [ps6000aStartFirmwareUpdate\(\)](#). The driver calls it back when the firmware update status changes.

Applicability

All modes

Arguments

`handle`, the device identifier returned by [ps6000aOpenUnit\(\)](#).

`progress`, a progress indicator.

Returns

nothing

4.4 PicoProbeInteractions() – callback for PicoConnect probe events

```
typedef void (PREF4 *PicoProbeInteractions)
(
    int16_t                handle,
    PICO_STATUS            status,
    PICO\_USER\_PROBE\_INTERACTIONS * probes,
    uint32_t               nProbes
)
```

This callback function handles notifications of probe changes on scope devices that support Pico intelligent probes.

If you wish to use this feature, you must create this function as part of your application. You register it with the ps6000a driver using [ps6000aSetProbeInteractionCallback\(\)](#) and the driver calls it back whenever a probe generates an error. See [Handling PicoConnect probe interactions](#) for more information on this process.

Applicability

All modes

Arguments

`handle`, the device identifier returned by [ps6000aOpenUnit\(\)](#).

`status`, indicates success or failure. If multiple errors have occurred, the most general error is returned here. Probe-specific errors are returned in the `status` field of the relevant elements of the probes array.

`probes`, on entry, pointer to an array of [PICO_USER_PROBE_INTERACTIONS](#) structures.

`nProbes`, the number of elements in the probes array.

Returns

nothing

4.4.1 PICO_USER_PROBE_INTERACTIONS structure

A structure of this type is passed to the [PicoProbeInteractions\(\)](#) callback function. It is defined as follows:

```
typedef struct tPicoUserProbeInteractions
{
    uint16_t                connected_;

    PICO_CHANNEL            channel_;
    uint16_t                enabled_;

    PicoConnectProbe        probeName_;

    uint8_t                 requiresPower_;
    uint8_t                 isPowered_;

    PICO_STATUS              status_;

    PICO_CONNECT_PROBE_RANGE probeOff_;

    PICO_CONNECT_PROBE_RANGE rangeFirst_;
    PICO_CONNECT_PROBE_RANGE rangeLast_;
    PICO_CONNECT_PROBE_RANGE rangeCurrent_;

    PICO_COUPLING            couplingFirst_;
    PICO_COUPLING            couplingLast_;
    PICO_COUPLING            couplingCurrent_;

    PICO_BANDWIDTH_LIMITER_FLAGS filterFlags_;
    PICO_BANDWIDTH_LIMITER_FLAGS filterCurrent_;

    PICO_BANDWIDTH_LIMITER   defaultFilter_;
} PICO_USER_PROBE_INTERACTIONS;
```

Elements

`connected_`, indicates whether the probe is connected or not. The driver saves information on disconnected probes in case they are reconnected, in which case it reapplies the previous settings.

`channel_`, the scope channel to which the probe is connected.

`enabled_`, indicates whether the probe is switched on or off.

`probeName_`, identifies the type of probe from the `PICO_CONNECT_PROBE` enumerated list defined in `PicoConnectProbes.h`.

For intelligent probes (those with circuitry enabling them to identify themselves to the driver and to apply signal scaling under the control of the driver) the following special values are defined:

`PICO_CONNECT_PROBE_NONE` = 0, if no probe is connected to the channel

`PICO_CONNECT_PROBE_INTELLIGENT` = -3, if a correctly functioning intelligent probe is connected to the channel

`PICO_CONNECT_PROBE_UNKNOWN_PROBE` = -2, if an intelligent probe is connected but cannot be identified

`PICO_CONNECT_PROBE_FAULT_PROBE = -1`, if an intelligent probe is connected but has suffered an internal error

`requiresPower_`, indicates whether the probe draws power from the scope.

`isPowered_`, indicates whether the probe is receiving power.

`status_`, a status code indicating success or failure. See `PicoStatus.h` for definitions.

`probeOff_`, the range in use when the probe was last switched off.

`rangeFirst_`, the first applicable range in the `PICO_CONNECT_PROBE_RANGE` enumerated list.

`rangeLast_`, the last applicable range in the `PICO_CONNECT_PROBE_RANGE` enumerated list.

`rangeCurrent_`, the range currently in use.

`couplingFirst_`, the first applicable coupling type in the `PS4000A_COUPLING` list.

`couplingLast_`, the last applicable coupling type in the `PS4000A_COUPLING` list.

`couplingCurrent_`, the coupling type currently in use.

`filterFlags_`, a bit field indicating which bandwidth limiter options are available.

`filterCurrent_`, the bandwidth limiter option currently selected.

`defaultFilter_`, the default bandwidth limiter option for this type of probe.

4.5 PicoExternalReferenceInteractions () - callback for external reference clock events

```
typedef void (CALLBACK * PicoExternalReferenceInteractions)
(
    int16_t                handle,
    PICO_STATUS            status,
    PICO_CLOCK_REFERENCE   reference
)
```

This callback function handles notifications when the status of the external 10 MHz reference clock changes. The PicoScope 6000 (A API) device automatically selects the external reference clock when a signal is applied to the external reference input, and uses this callback function to inform your application of the change (and whether the external reference signal is valid).

Register your callback function with the driver using [ps6000aSetExternalReferenceInterationCallback \(\)](#)

Applicability

All models

Arguments

`handle`, the device identifier returned by [ps6000aOpenUnit\(\)](#).

`status`, indicates success or failure. Status codes can be:

`PICO_OK`: the device is synchronized to the clock source indicated by the `reference` parameter

`PICO_NOT_LOCKED_TO_REFERENCE_FREQUENCY`: the device is unable to synchronize to the clock source, for example because its frequency is out of range. The timebase accuracy is out of specification in this situation.

Another status from `PicoStatus.h` may be returned, for example if the device has been disconnected.

`reference`, indicates whether the internal or external clock source is in use. The available values are one of the `PICO_CLOCK_REFERENCE` enumerated type.

Returns

Nothing

4.5.1 PICO_CLOCK_REFERENCE enumerated type

An enum of this type is passed to the `PicoExternalReferenceInteractions()` callback function. It is defined as follows:

```
typedef enum enPicoClockReference
{
    PICO_INTERNAL_REF,
    PICO_EXTERNAL_REF
} PICO_CLOCK_REFERENCE;
```

Applicability

Calls to [PicoExternalReferenceInteractions\(\)](#) - callback for external reference clock events

Values

`PICO_INTERNAL_REF`, indicates that the internal clock is being used by the device.

`PICO_EXTERNAL_REF`, indicates that the external clock is being used by the device.

5 Reference

5.1 Numeric data types

Here is a list of the numeric data types used in the ps6000a API:

Type	Bits	Signed or unsigned?
int16_t	16	signed
uint16_t	16	unsigned
enum	32	enumerated
int32_t	32	signed
uint32_t	32	unsigned
float	32	signed (IEEE 754)
double	64	signed (IEEE 754)
int64_t	64	signed
uint64_t	64	unsigned

5.2 Enumerated types and constants

The enumerated types and constants used in the PicoScope 6000E Series API driver are defined in the file `ps6000aApi.h`, which is included in the SDK. We recommend that you refer to these constants by name unless your programming language allows only numerical values.

5.3 Driver status codes

Every function in the ps6000a driver returns a **driver status code** from the list of `PICO_STATUS` values in the file `PicoStatus.h`, which is included in the Pico Technology SDK. Not all codes in `PicoStatus.h` apply to the PicoScope 6000E Series.

5.4 Glossary

Callback. A mechanism that the PicoScope 6000 driver uses to communicate asynchronously with your application. At design time, you add a function (a *callback* function) to your application to deal with captured data. At run time, when you request captured data from the driver, you also pass it a pointer to your function. The driver then returns control to your application, allowing it to perform other tasks until the data is ready. When this happens, the driver calls your function in a new thread to signal that the data is ready. It is then up to your function to communicate this fact to the rest of your application.

Driver. A program that controls a piece of hardware. The driver for the PicoScope 6000E Series oscilloscopes is supplied in the form of 32-bit and 64-bit Windows DLLs called `ps6000a.dll`. These are used by your application to control the oscilloscope.

PicoScope 6000E Series. A range of PC Oscilloscopes from Pico Technology, with a maximum sampling rate of up to 10 GS/s. Sampling resolutions range from 8 to 12 bits and capture memory sizes from 1 to 4 GS.

PRBS (pseudo-random binary sequence). A fixed, repeating sequence of binary digits that appears random when analyzed over a time shorter than the repeat period. The waveform swings between two values: logic high (binary 1) and logic low (binary 0).

USB 2.0. The second generation of USB (universal serial bus) interface. The port supports a data transfer rate of up to 480 megabits per second.

USB 3.0. A USB 3.0 port uses signaling speeds of up to 5 gigabits per second and is backwards-compatible with USB 2.0.

UK headquarters:

Pico Technology
James House
Colmworth Business Park
St. Neots
Cambridgeshire
PE19 8YP
United Kingdom

Tel: +44 (0) 1480 396 395

sales@picotech.com
support@picotech.com

US regional office:

Pico Technology
320 N Glenwood Blvd
Tyler
TX 75702
USA

Tel: +1 800 591 2796

sales@picotech.com
support@picotech.com

Asia-Pacific regional office:

Pico Technology
Room 2252, 22/F, Centro
568 Hengfeng Road
Zhabei District
Shanghai 200070
PR China

Tel: +86 21 2226-5152

pico.asia-pacific@picotech.com

Germany regional office and EU Authorized Representative:

Pico Technology GmbH
Im Rehwinkel 6
30827 Garbsen
Germany

Tel: +49 (0) 5131 907 62 90

info.de@picotech.com

www.picotech.com

ps6000apg-5

Copyright © 2021–2024 Pico Technology Ltd. All rights reserved.

