

3060

M STREET NW

— Georgetown —

3060

M STREET NW

— Georgetown —

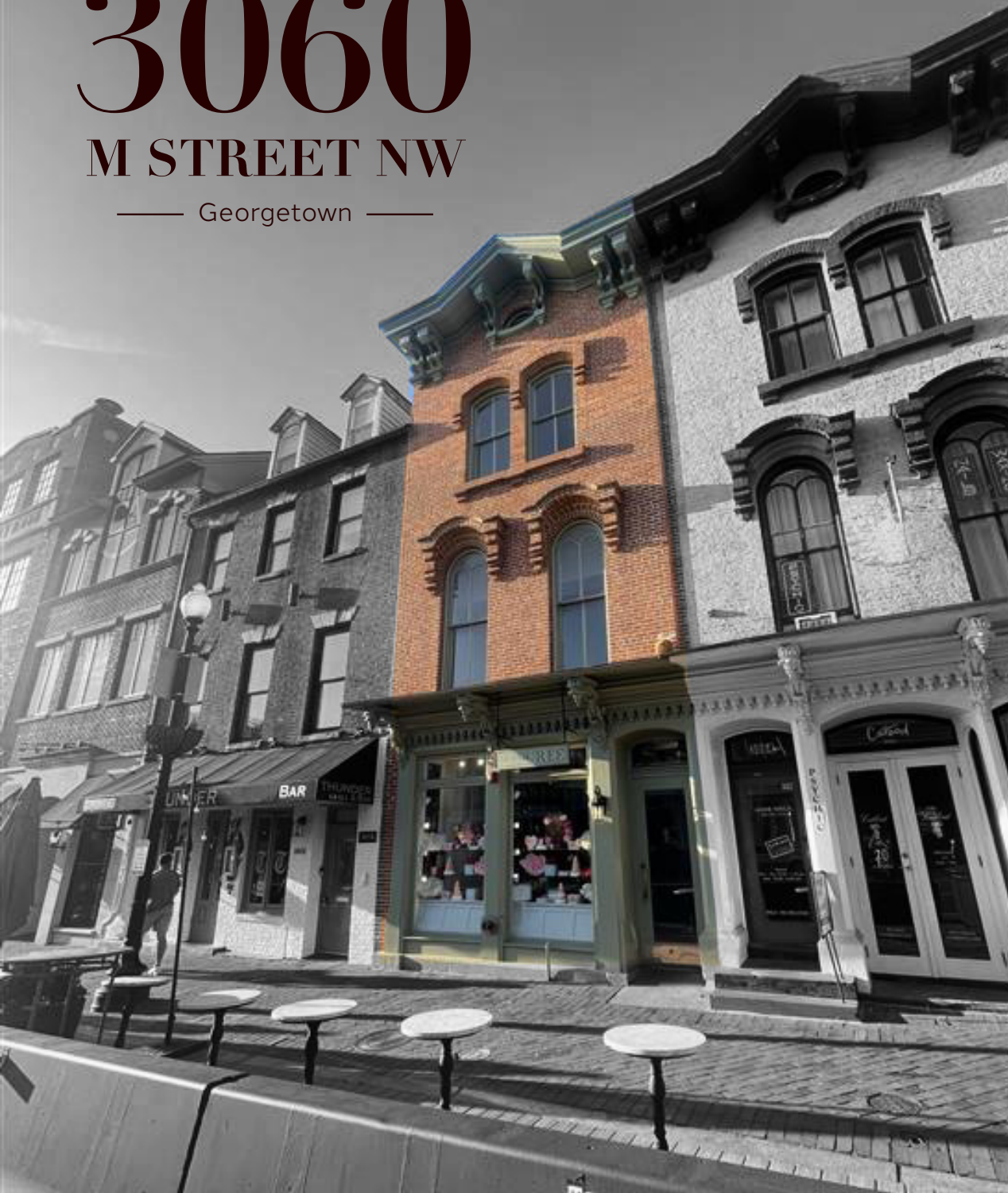

PROPERTY HIGHLIGHTS

4 floors

of retail space available

3,196 SF

Cellar Floor - 850 SF

Ground Floor - 950 SF

2nd Floor - 496 SF

3rd Floor - 900 SF

Incredible Opportunity

Coveted retail space located on M Street., in between Thomas Jefferson St and 31st St.

Spectacular Conditions

High end finishes on ground floor, existing kitchen located on 2nd floor.

Premier Location

Located in DC's most prolific high street.

Retail Destination

Central to most lifestyle brands. 100+ number of retailers in the trade area with 60+ new businesses opening in 2023.

Profound Demographics

Georgetown residents boast an average household income of \$192,731 with over 40% holding graduate level degrees.

M STREET RETAIL



M Street NW - 31,203 VPD



Historical Old Stone House

- Brandy Melville
- Alice + Olivia
- Georgetown Cupcake
- Salty Donut
- Club Monaco
- Good Stuff Eatery
- Georgetown Piano Bar
- Sugar Lab DC
- Bitty Hicks
- Aesop
- Diptyque
- Lululemon
- Fharety
- Everlane
- Chipotle
- Nisolo
- Sephora
- Rails
- Away
- Aerie
- Warby Parker
- Barbour
- Sunglass Hut
- Todd Snyder
- Bitty & Beau's Coffee
- Cos
- PNC Bank
- New Balance
- All Birds
- Levain Bakery
- Sport and Social
- James Allen
- Frame
- State and Liberty
- Rag & Bone
- Blue Mercury
- Farm Rio
- Truist Bank
- LaNnexe
- L'Avant Garde
- Izzy Salon
- Wells Fargo Bank
- CVS
- Villa Yara
- Afghanistan

- Waterworks
- Malteni & Co
- Poliform
- Studs
- Pizzeria Paradiso
- J. McLaughlin
- Coming soon: Osteria Mozza
- Gold's Gym
- J Crew
- TJ Maxx
- H&M
- Olfactory NYC
- Clyde's
- Anthropologie
- Vuori
- Aritzia
- City Tavern Club
- Alo Yoga
- Capital One Cafe
- Chase Bank
- Buck Mason
- Smoothie King
- Haagen Dazs
- Bodega
- Hatley Boutique
- Up West
- Doc Marten
- L'occitane
- Patagonia
- Potomac Wine
- Rothys
- Caroline
- Thunderbolts
- Barnes & Noble
- Ray Ban
- United Bank
- Indochino
- Angolo Ristorante
- Niccolo Giottoo
- Yuna GT
- Mugsy
- Suit Supply
- Amina Rubinacci
- DTR Modern Galleries
- Bridge Street Books
- Lugano Diamonds

K Street NW

PREMIER LOCATION

Georgetown, located in Washington, DC, has long been recognized as the thriving retail epicenter and sought-after tourist shopping destination of the city. Despite the emergence of competitive high streets, Georgetown remains highly desirable to national retailers and continues to attract new tenants. The neighborhood boasts a wealthy and educated population, with residents earning an impressive average income of \$180,000-\$200,000. Georgetown also sits between a dense student population of 50,000+ in respect to Georgetown University and George Washington University. Additionally, while Georgetown lacks a Metro station, its unique charm and vibrant offerings make it a destination worth visiting for both drivers and non-drivers alike. Georgetown is home to a multitude of attractions, including prestigious hotels and the popular Washington Harbour which provides a rare opportunity for water-side dining along the Potomac River, boasts incredible views of the Kennedy Center, and is home to a magnificent fountain that transforms into an ice-skating rink in the Winter for added entertainment. M Street and Wisconsin Avenue serve as bustling thoroughfares brimming with high-end boutiques and renowned brands, catering to fashion-conscious shoppers from near and far. Furthermore, Georgetown's real estate market features exciting redevelopment projects that repurpose existing spaces and create dynamic mixed-use environments combining residential and retail components. In addition, standalone retail spaces contribute to the area's economic growth, making Georgetown an even more enticing destination for both businesses and visitors.



DEMOGRAPHICS

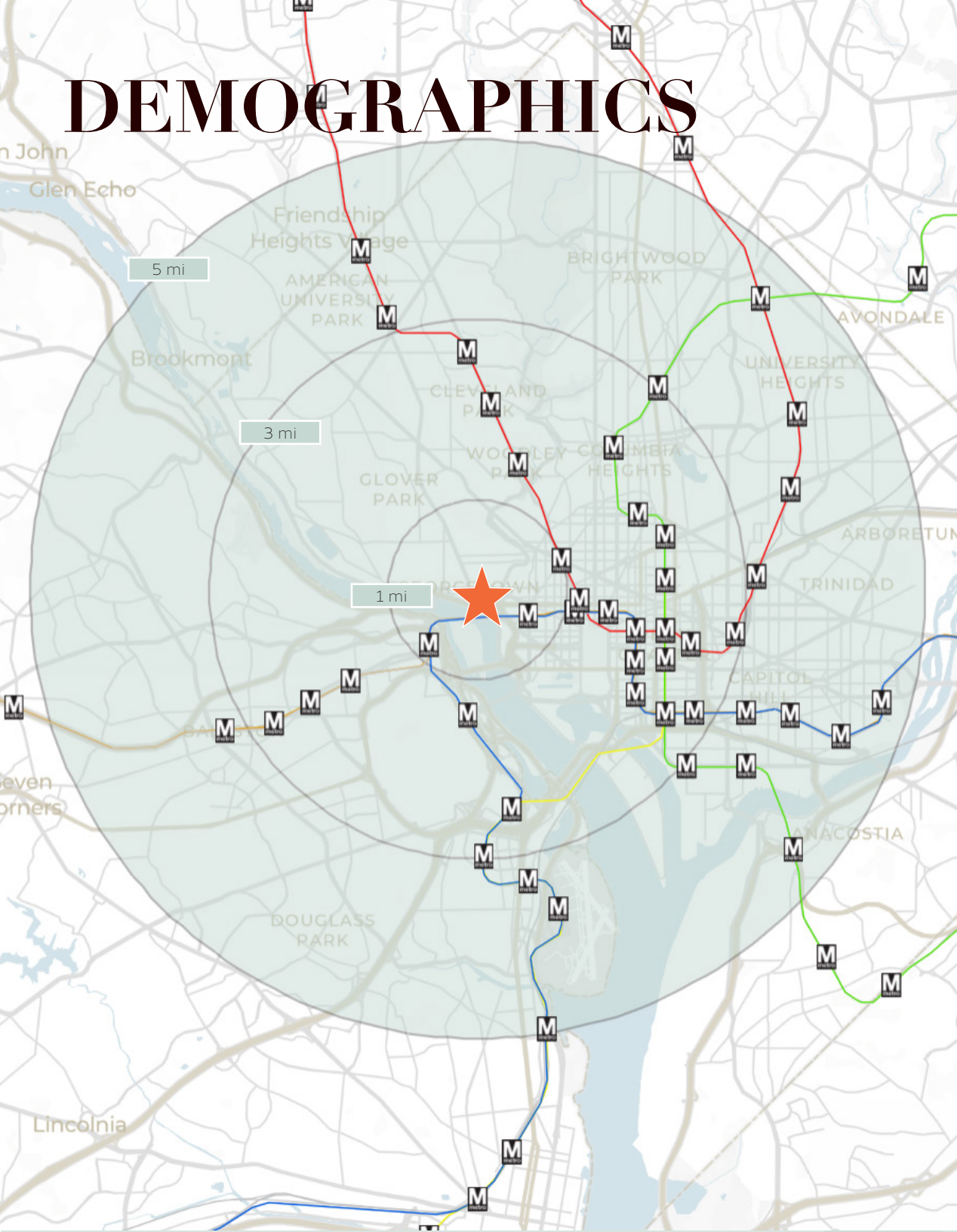

1 mile

126,116
Total Population

20,045
Total Households

\$192,731
Average HH Income

3 miles

822,229
Total Population

182,790
Total Households

\$184,871
Average HH Income

5 miles

1,343,699
Total Population

383,229
Total Households

\$181,963
Average HH Income

FLOOR PLANS

Cellar Floor

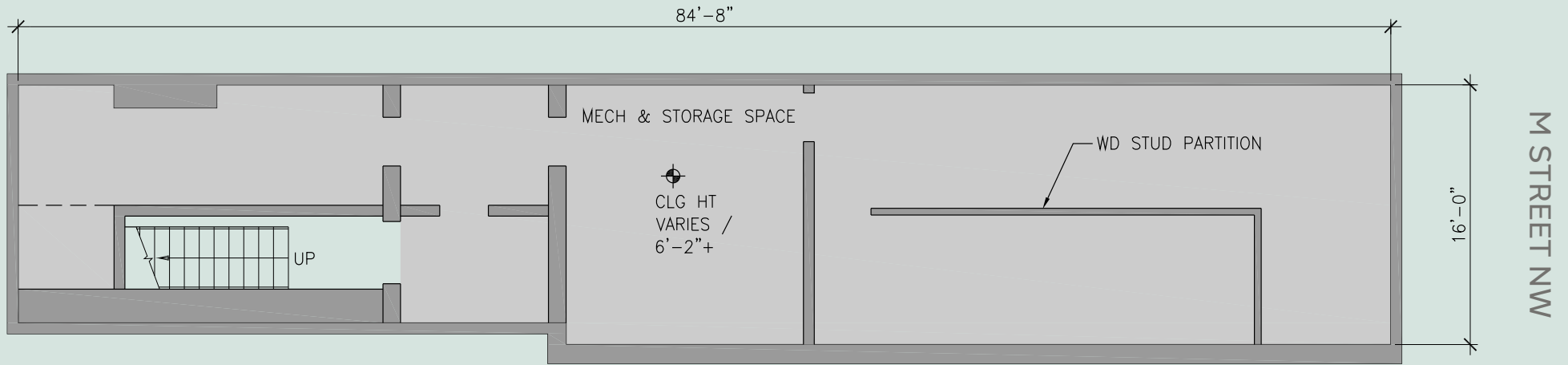

Ground Floor

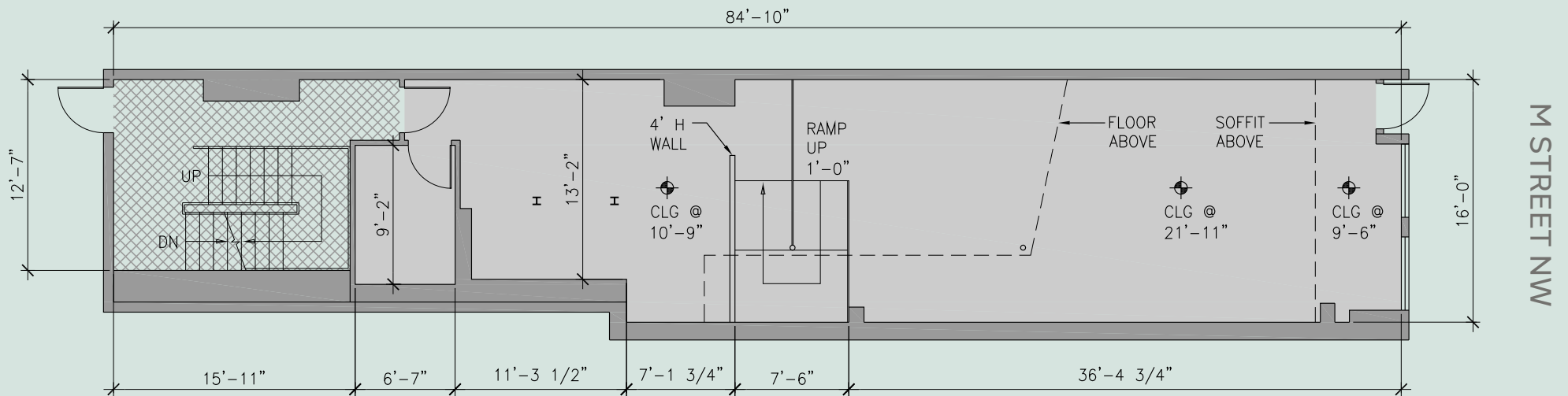

FLOOR PLANS

2nd Floor

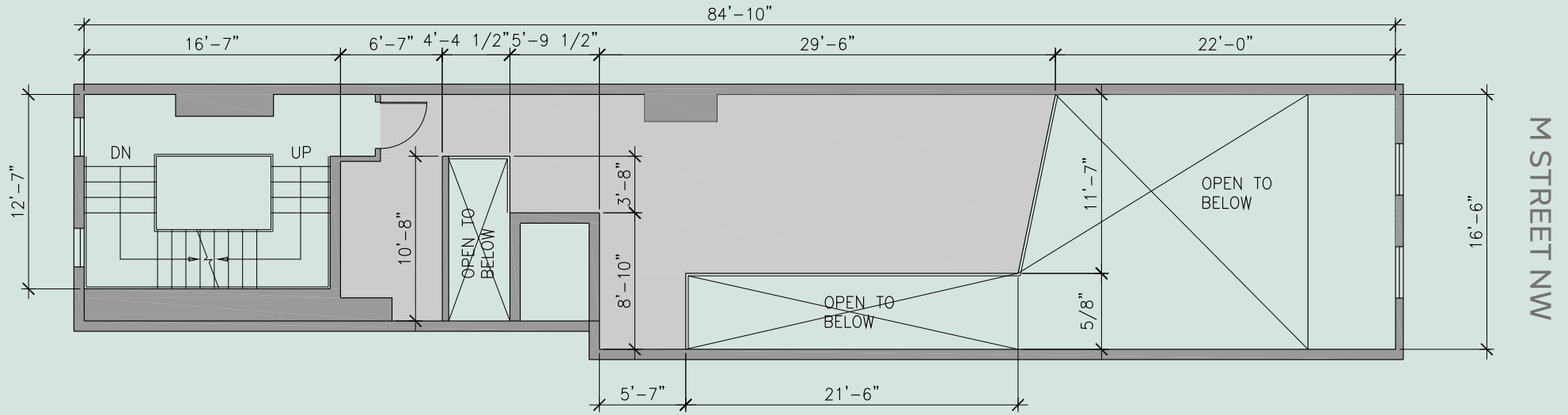

3rd Floor

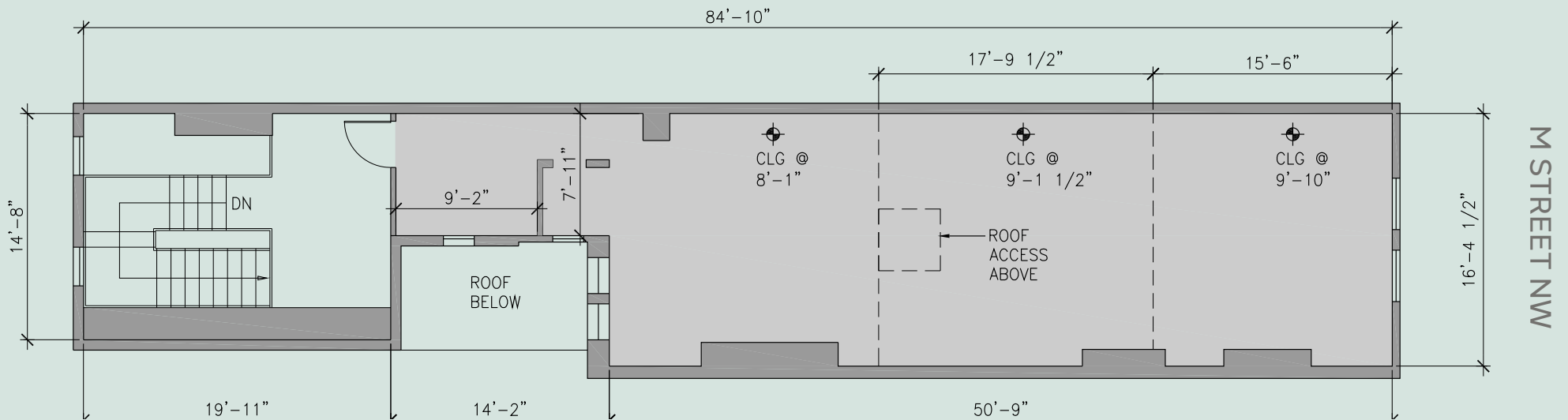

3060

M STREET NW

— Georgetown —

Andy Corno
O: 202 719 6137
M: 301 520 2620
Andy.Corno@jll.com

Thomas Jackman
O: 202 719 5624
M: 301 580 1512
Thomas.Jackman@jll.com

Simms Henschel
O: 202 533 2529
M: 301 332 5220
Simms.Henschel@jll.com

