



Γ. ΚΑΤΣΑΦΑΔΟΣ ΛΤΔ
ΑΝΤΙΠΡΟΣΩΠΟΙ ΔΙΑΝΟΜΕΙΣ

12/2023
EDITION

Τρυπάνια - Αρίδες

Μετάλλου, Ξύλου, Μπετού, Πέτρας, Κεραμικού, Γυαλιού,
Ποτηροτρύπανα, Βαρέου Τύπου, Καλέμια κ.α.

Κιλκίς 31Α, 2234 Λατσία 17101, CY-2261 Λευκωσία, Κύπρος
Τηλ.: +357 22 46 76 86 - Fax: +357 22 87 89 20
info@katsafados.com

www.katsafados.com

KEIL

MAXITOWER

Attractive additional turnover on the counter

- Περιστερόμενο Σταντ 3 όψεων
- Ευέλικτες δυνατότητες τοποθέτησης
- Απαιτείται ελάχιστος χώρος

Art. No.: A1.000.101.005

Διαστάσεις: 52cm x 180cm

KEIL

MINITOWER

Attractive additional turnover on the counter

- Περιστερόμενο Σταντ 4 όψεων
- Ευέλικτες δυνατότητες τοποθέτησης
- Απαιτείται ελάχιστος χώρος

Art. No.: A1.000.101.006

Διαστάσεις: 19cm x 70cm

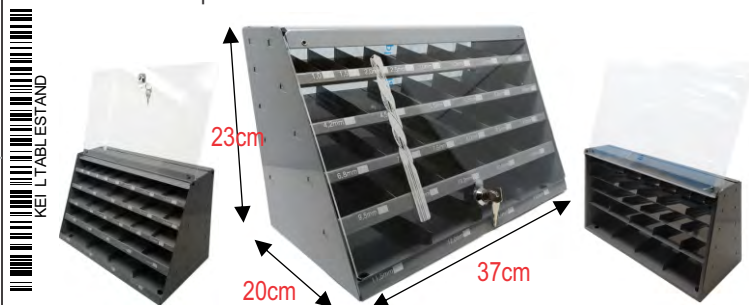
 UNIT Αδειο Μεταλλικό Επιτραπέζιο Σταντ για Τρυπάνια (αρίδες)
 Διάσταση: 20x37x23cm

KEIL Table Metal Display Empty Stand - A1.384.300.030

UNIT Σταντ με Τρυπάνια (αρίδες)



Αρίδες (τρυπάνια) Μπετού

MAXITOWER SDS-plus / -max

- SDS-plus MS5 TURBOHEAD Xpro
- SDS-plus MS5 TURBOKEIL
- SDS-max W2 TURBOHEAD XPRO
- SDS-max W2 TURBOKEIL X-FORM
- SDS-plus Chisel
- SDS-max Chisel

320
ΤΕΜ

Art. No.: A8.253.900.320.099

KEIL MAXITOWER SDS Plus - A8.253.900.320.099

UNIT Σταντ με Τρυπάνια (αρίδες)



Αρίδες (τρυπάνια) Πέτρας

MAXITOWER Stone drill bits

- GOLDCRAFT Universal drill bits (All Kinds)
- KEILER Percussion drill bits
- Glas drill bits
- Tile/brick drill bits KERAMIK
- Concrete drill bits MS5 TURBOHEAD Xpro
- Concrete drill bits MS5 TURBOKEIL
- Hollow core drill bits M16 assembly
- Hollow core drill bit M16

584
ΤΕΜ

KEIL MAXITOWER Stone Drill Bits - A8.119.900.584.099

UNIT Σταντ με Τρυπάνια (αρίδες)



MAXITOWER „All inclusive“

- SDS-plus MS5 TURBOHEAD Xpro
- SDS-plus MS5 TURBOKEIL
- SDS-max TURBOHEAD / TURBOKEIL
- Various SDS-plus & SDS-max chisels
- Universal drill bits GOLDCRAFT
- Hard stone drill bits HARDTEC
- Concrete drill bits MS5 TURBOKEIL
- Percussion drill bits KEILER

838
ΤΕΜ

Art. No.: A8.253.900.838.099

KEIL MAXITOWER All Inclusive - A8.253.900.838.099

- Holow core drill bit sets
- HSS-E DIN 338 Cobalt, ground, SPLIT POINT
- HSS-G DIN 338 ground, SPLIT POINT
- HSS Sets - Standard / Ground / Cobalt
- Wood drill bits
- Flat bits
- AUGER drill bits

Αρίδες (τρυπάνια) Παντός Τύπου

UNIT Σταντ με Τρυπάνια (αρίδες)



Αρίδες (τρυπάνια) SDS

MINITOWER SDS-plus

- SDS-plus MS5 TURBOKEIL
- SDS-plus MS5 TURBOHEAD Xpro
- Pointed-, flat- and spade chisel

Art. No.: A8.253.900.188.099
188
ΤΕΜ

KEIL MINITOWER SDS Plus - A8.253.900.188.099

UNIT Σταντ με Τρυπάνια (αρίδες)



Αρίδες (τρυπάνια) Μπετού

MINITOWER Concrete drill bits

- GOLDCRAFT Universal drill bits
- HARDTEC Hardstone drill bits
- Tile drill bits / KERAMIK DIAMOND
- Concrete drill bits TURBOKEIL

Art. No.: A8.119.900.182.099
182
ΤΕΜ

KEIL MINITOWER CONCRETE - A8.119.900.182.099

UNIT Σταντ με Τρυπάνια (αρίδες)



Αρίδες (τρυπάνια) Μετάλλου

MINITOWER Metal drill bits

- HSS DIN 338 Standard
- HSS-G DIN 338 ground SPLIT POINT
- HSS TIN DIN 338 Steel drill bits
- HSS-E DIN 338 Cobalt ground SPLIT POINT
- 19 pcs - Set of the above mentioned drill bit types

Art. No.: A5.300.900.540.099
540
ΤΕΜ

KEIL MINITOWER METAL - A5.300.900.540.099

UNIT Σταντ με Τρυπάνια (αρίδες)



Αρίδες (τρυπάνια) Ξύλου

MINITOWER Wood drill bits

- Wood twist Drill Bits
- Flat bits
- AUGER drill bits
- Forstner drill bits

Art. No.: A5.180.900.291.099
291
ΤΕΜ

KEIL MINITOWER WOOD - A5.180.900.291.099



UNIT Τρυπάνια (αρίδες) 1/4" HEX Μετάλλου, Ξύλου & Πλαστικού, Υψηλής Ταχύτητας & Απόδοσης Χάλυβας, Δεξιάς Κοπής, Κωνικό: 135°

NEW

Ø 2mm	Ø 3mm	Ø 4mm	Ø 5mm	Ø 6mm	Ø 7mm	Ø 8mm	Ø 9mm	Ø 10mm	Ø 11mm	Ø 12mm
797202	797172	797110	797103	797042	797035	797028	797011	797004	796991	796984
(826)	(827)	(828)	(829)	(830)	(831)	(832)	(833)	(834)	(835)	(836)

CGW HSS 1/4" Hex Shank Wood, Metal, Plastic Drill Bit

UNIT Τρυπάνια (αρίδες) Μετάλλου, Υψηλής Ταχύτητας & Απόδοσης Χάλυβας, Δεξιάς Κοπής N, Κωνικό: 118°, Ανοχής H8, σε Σακουλάκι x1

Ø 1mm	Ø 1,5mm	Ø 2mm	Ø 2,5mm	Ø 3mm	Ø 3,2mm	Ø 3,3mm	Ø 3,5mm	Ø 4mm
300/320/100	300/320/150	300/320/200	300/320/250	300/320/300	300/320/320	300/320/330	300/320/350	300/300/400
(658)	(657)	(656)	(659)	(655)	(654)	(653)	(652)	(651)

KEIL HSS DIN 338 Standard 300 Pouch

Τρυπάνια (αρίδες) Μετάλλου, Υψηλής Ταχύτητας & Απόδοσης Χάλυβας, Δεξιάς Κοπής N, Κωνικό: 118°, Ανοχής H8, σε Σακουλάκι x1

Ø 4,2mm	Ø 4,5mm	Ø 5mm	Ø 5,5mm	Ø 6mm	Ø 6,5mm	Ø 7mm	Ø 7,5mm	Ø 8mm	Ø 8,5mm	Ø 9mm
300/300/420	300/300/450	300/300/500	300/300/550	300/300/600	300/300/650	300/300/700	300/300/750	300/300/800	300/300/850	300/300/900
(650)	(649)	(648)	(647)	(646)	(645)	(644)	(643)	(642)	(641)	(640)

KEIL HSS DIN 338 Standard 300 Pouch

Τρυπάνια (αρίδες) Μετάλλου, Υψηλής Ταχύτητας & Απόδοσης Χάλυβας, Δεξιάς Κοπής N, Κωνικό: 118°, Ανοχής H8, σε Σακουλάκι x1

Ø 9,5mm	Ø 10mm	Ø 11mm	Ø 12mm	Ø 13mm
300/300/950	300/301/000	300/301/100	300/301/200	300/301/300
(660)	(639)	(638)	(637)	(636)

KEIL HSS DIN 338 Standard 300 Pouch

SET Τρυπάνια (αρίδες) Μετάλλου σε Θήκη, 5 τεμ. Ø 4, 5, 6, 8, 10mm
Υψηλής Ταχύτητας,
Υψηλής Απόδοσης
Χάλυβας,
Δεξιάς Κοπής N
Κωνικό: 118°
Ανοχής H8













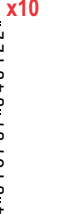

KEIL HSS DIN 338 Standard, 5ps, 300.350.410 (808)

SET Τρυπάνια (αρίδες) Μετάλλου σε Θήκη, 13 τεμ. Ø 1,5 - 6,5 / 0,5 mm
Υψηλής Ταχύτητας,
Υψηλής Απόδοσης
Χάλυβας,
Δεξιάς Κοπής N
Κωνικό: 118°
Ανοχής H8

KEIL HSS DIN 338 Standard, 13ps, 300.213.165 (809)













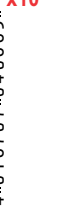

10x1 Τρυπάνια (αρίδες) Μετάλλου, Υψηλής Ταχύτητας & Απόδοσης Χάλυβας, Δεξιάς Κοπής N, Κωνικό: 118°, Ανοχής H8, σε Κουτί x10

															
	x10	x10	x10	x10	x10	x10	x10	x10	x10	x10	x10	x10	x10	x10	x10
	Ø 1mm	Ø 1,5mm	Ø 2mm	Ø 2,5mm	Ø 3mm	Ø 3,3mm	Ø 3,5mm	Ø 4mm	Ø 4,2mm	Ø 4,5mm					
	300/000/100	300/000/150	300/000/200	300/000/250	300/000/300	300/000/330	300/000/350	300/000/400	300/000/420	300/000/450					
	(335)	(334)	(333)	(140)	(331)	(332)	(330)	(329)	(328)	(327)					





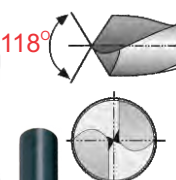



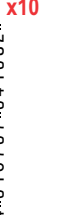

KEIL HSS DIN 338 Standard 300 BOX x10

10x1 Τρυπάνια (αρίδες) Μετάλλου, Υψηλής Ταχύτητας & Απόδοσης Χάλυβας, Δεξιάς Κοπής N, Κωνικό: 118°, Ανοχής H8,

														
	x10	x10	x10	x10	x10	x10	x10	x10	x10	x10	x10	x10		
	Ø 5mm	Ø 5,5mm	Ø 6mm	Ø 6,5mm	Ø 7mm	Ø 7,5mm	Ø 8mm	Ø 8,5mm	Ø 9mm					118°
	300/000/500	300/000/550	300/000/600	300/000/650	300/000/700	300/000/750	300/000/800	300/000/850	300/000/900					
	(326)	(139)	(138)	(324)	(325)	(137)	(323)	(322)	(321)					

KEIL HSS DIN 338 Standard 300 BOX x10

10x1 Τρυπάνια (αρίδες) Μετάλλου, Υψηλής Ταχύτητας & Απόδοσης Χάλυβας, Δεξιάς Κοπής N, Κωνικό: 118°, Ανοχής H8,

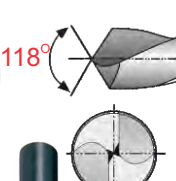
											
	x10	x10	x5	x5	x5						
	Ø 9,5mm	Ø 10mm	Ø 11mm	Ø 12mm	Ø 13mm						118°
	300/000/950	300/001/000	300/001/100	300/001/200	300/001/300						
	(136)	(320)	(319)	(318)	(317)						

KEIL HSS DIN 338 Standard 300 BOX x10

SET Τρυπάνια (αρίδες) Μετάλλου σε Θήκη, 19 τεμ. Ø 1 - 10 / 0,5 mm
Υψηλής Ταχύτητας,
Υψηλής Απόδοσης Χάλυβας,
Δεξιάς Κοπής N
Κωνικό: 118°
Ανοχής H8





KEIL HSS DIN 338 Standard, 19ps, 300.501.110 (691)

SET Τρυπάνια (αρίδες) Μετάλλου σε Θήκη, 25 τεμ. Ø 1 - 13 / 0,5 mm
Υψηλής Ταχύτητας,
Υψηλής Απόδοσης Χάλυβας,
Δεξιάς Κοπής N
Κωνικό: 118°
Ανοχής H8





KEIL HSS DIN 338 Standard, 25ps, Metal Box 300.500.113 (145)

SET Τρυπάνια (αρίδες) Μετάλλου σε Θήκη, 25 τεμ. Ø 1 - 13 / 0,5 mm
Υψηλής Ταχύτητας,
Υψηλής Απόδοσης Χάλυβας,
Δεξιάς Κοπής N
Κωνικό: 118°
Ανοχής H8





KEIL HSS DIN 338 Standard, 25ps, 300.501.113 (689)

SET Τρυπάνια (αρίδες) Μετάλλου σε Θήκη, 170 τεμ. Ø 1 - 10 / 0,5 mm





KEIL Bits HSS DIN 338 Standard, 170ps, 300.800.170 (499)



5x1 Τρυπάνια (αρίδες) Μετάλλου, Υψηλής Ταχύτητας & Απόδοσης Χάλυβας, Δεξιάς Κοπής N, Κωνικό: 118°, Ανοχής H8

x5	x5	x5	x5	x5	x5	x5	x5	x5	x5	x5
Ø 14mm	Ø 14,5mm	Ø 15mm	Ø 15,5mm	Ø 16mm	Ø 17mm	Ø 18mm	Ø 16mm	Ø 16,5mm	Ø 17mm	
300/140/100	300/145/100	300/150/100	300/155/100	300/160/100	300/170/100	300/180/100	300/160/130	300/165/130	300/170/130	
(509)	(508)	(507)	(506)	(537)	(136A)	(125A)	(505)	(504)	(503)	

Germany

HSS DIN 338, Standard, Shank 300, 5pcs

5x1 Τρυπάνια (αρίδες) Μετάλλου, Υψηλής Ταχύτητας & Απόδοσης Χάλυβας, Δεξιάς Κοπής N, Κωνικό: 118°, Ανοχής H8

x5	x5	x5	x5
Ø 18mm	Ø 19mm	Ø 20mm	Ø 20mm
300/180/130	300/190/130	300/200/100	300/200/130
(502)	(501)	(139A)	(500)

Germany

HSS DIN 338, Standard, Shank 300, 5pcs

UNIT Τρυπάνια (αρίδες) Μετάλλου, Υψηλής Ταχύτητας & Απόδοσης Χάλυβας, με επικάλυψη Κασσίτερου, Δεξιάς Κοπής N, Κωνικό: 118°, Ανοχής H8, DIN 1412 C Κατάλληλα για Ανοξειδωτο Ατσάλι

x2	x2	x2	x2	x2				
Ø 1mm	Ø 2mm	Ø 2,5mm	Ø 3mm	Ø 3,5mm	Ø 4mm	Ø 4,2mm	Ø 4,5mm	
311/320/000	311/320/020	311/320/025	311/320/030	311/320/035	311/300/040	311/300/042	311/300/045	
(443)	(442)	(441)	(440)	(439)	(438)	(437)	(436)	

Germany

KEIL HSS TIN DIN 338, Ground, Split Point 311, Steel Drill Bits in Pouch

Τρυπάνια (αρίδες) Μετάλλου, Υψηλής Ταχύτητας & Απόδοσης Χάλυβας, με επικάλυψη Κασσίτερου, Δεξιάς Κοπής N, Κωνικό: 118°, Ανοχής H8, DIN 1412 C Κατάλληλα για Ανοξειδωτο Ατσάλι

Ø 5mm	Ø 5,5mm	Ø 6mm	Ø 6,5mm	Ø 7mm	Ø 7,5mm	Ø 8mm	Ø 8,5mm	Ø 9mm	Ø 9,5mm
311/300/050	311/300/055	311/300/060	311/300/065	311/300/070	311/300/075	311/300/085	311/300/085	311/300/090	311/300/095
(435)	(434)	(433)	(432)	(431)	(430)	(429)	(428)	(427)	(426)

KEIL HSS TIN DIN 338, Ground, Split Point 311, Steel Drill Bits in Pouch

Τρυπάνια (αρίδες) Μετάλλου, Υψηλής Ταχύτητας & Απόδοσης Χάλυβας, με επικάλυψη Κασσίτερου, Δεξιάς Κοπής N, Κωνικό: 118°, Ανοχής H8, DIN 1412 C Κατάλληλα για Ανοξειδωτο Ατσάλι



















Ø 10mm	Ø 10,5mm	Ø 11mm	Ø 12mm	Ø 13mm
311/300/100	311/300/105	311/300/110	311/300/120	311/300/130
(425)	(424)	(423)	(422)	(421)

Edelstahl Rost frei

KEIL HSS TIN DIN 338, Ground, Split Point 311, Steel Drill Bits in Pouch



UNIT Επαγγελματικά Τρυπάνια (αρίδες) Μετάλλου, Υψηλής Ταχύτητας & Απόδοσης Χάλυβας, Διπλής Κοπής, Κωνικό: 118°, Ανοχής H8, DIN 1412 C





































Germany

Ø 2mm	Ø 3mm	Ø 4mm	Ø 4,2mm	Ø 5mm	Ø 6mm	Ø 8mm	Ø 10mm
302/320/200	302/320/300	302/300/400	302/300/420	302/300/500	302/300/600	302/300/800	302/301/000
(296)	(297)	(298)	(299)	(300)	(301)	(302)	(303)

KEIL HSS DIN 338, Ground, Split Point 302, in Pouch

UNIT Επαγγελματικά Τρυπάνια (αρίδες) Μετάλλου, Υψηλής Ταχύτητας & Απόδοσης Χάλυβας, Διπλής Κοπής, Κωνικό: 118°, Ανοχής H8, DIN 1412 C σε Κουτί x10





























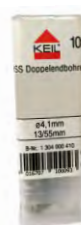













Germany

Ø 1mm	Ø 2mm	Ø 3mm	Ø 4mm	Ø 5mm	Ø 6mm	Ø 7mm	Ø 8mm
302/000/100	302/000/200	302/000/300	302/000/400	302/000/500	302/000/600	302/000/700	302/000/800
(533)	(532)	(531)	(530)	(529)	(528)	(527)	(526)

KEIL HSS DIN 338, Ground, Split Point 302, in Box 10pcs

UNIT Επαγγελματικά Τρυπάνια (αρίδες) Μετάλλου, Υψηλής Ταχύτητας & Απόδοσης Χάλυβας, Διπλής Κοπής, Κωνικό: 118°, Ανοχής H8, DIN 1412 C σε Κουτί x10

Germany

Ø 10mm	Ø 11mm	Ø 12mm	Ø 13mm
302/001/000	302/001/100	302/001/200	302/001/300
(525)	(524)	(523)	(522)

KEIL HSS DIN 338, Ground, Split Point 302, in Box 10pcs

SET Τρυπάνια (αρίδες) Μετάλλου σε Θήκη, 5 τεμ. Ø 4, 5, 6, 8, 10mm Υψηλής Ταχύτητας, Υψηλής Απόδοσης Χάλυβας, Διπλής Κοπής, Κωνικό: 118°, Ανοχής H8, DIN 1412 C









Germany

KEIL HSS DIN 338, Ground, Split Point 302, 5pcs 302.350.410 (811)

SET Τρυπάνια (αρίδες) Μετάλλου σε Θήκη, 170 τεμ. Ø 1 - 10 / 0,5 mm









Germany

KEIL Bits HSS DIN 338 Ground, Split Point, 170ps, 302.800.170 (751)

SET Τρυπάνια (αρίδες) Μετάλλου σε Θήκη, 19 τεμ. Ø 1 - 10 / 0,5 mm Υψηλής Ταχύτητας, Υψηλής Απόδοσης Χάλυβας, Διπλής Κοπής, Κωνικό: 118°, Ανοχής H8, DIN 1412 C









Germany

KEIL HSS DIN 338 Ground, Split Point, 19ps, 302.500.110 (142)



UNIT Τρυπάνια (αρίδες) Μετάλλου, Υψηλής Ταχύτητας, Κοβαλτίου (5%), Ανθεκτικό σε Συγκολλήσεις, Δεξιάς Κοπής N, Κωνικό: 135°, Ανοχής H8.

Κατάλληλα για Ανοξειδωτο Ατσάλι

x2	x2	x2	x2	x2			
410167071062926	410167071062940	410167071062957	410167071062964	410167071062995	410167071063084	410167071063091	410167071063107
Ø 1mm	Ø 2mm	Ø 2,5mm	Ø 3mm	Ø 3,5mm	Ø 4mm	Ø 4,2mm	Ø 4,5mm
307/320/100 (626)	307/320/200 (625)	307/320/250 (624)	307/320/300 (623)	307/320/350 (622)	307/300/400 (621)	307/300/420 (620)	307/300/450 (619)

KEIL HSS-E DIN 338 Cobalt, Ground, Split Point 307 Bits in Pouch

Τρυπάνια (αρίδες) Μετάλλου, Υψηλής Ταχύτητας, Κοβαλτίου (5%), Ανθεκτικό σε Συγκολλήσεις, Δεξιάς Κοπής N, Κωνικό: 135°, Ανοχής H8

Κατάλληλα για Ανοξειδωτο Ατσάλι

410167071063114	410167071063138	410167071063145	410167071063152	410167071063178	410167071063183	410167071063190	410167071063206	410167071063213	410167071063220
Ø 5mm	Ø 5,5mm	Ø 6mm	Ø 6,5mm	Ø 7mm	Ø 7,5mm	Ø 8mm	Ø 8,5mm	Ø 9mm	Ø 9,5mm
307/300/500 (618)	307/300/500 (617)	307/300/600 (616)	307/300/650 (615)	307/300/700 (614)	307/300/750 (613)	307/300/800 (612)	307/300/850 (611)	307/300/900 (610)	307/300/950 (609)

KEIL HSS-E DIN 338 Cobalt, Ground, Split Point 307 Bits in Pouch

UNIT Τρυπάνια (αρίδες) Μετάλλου, Υψηλής Ταχύτητας, Κοβαλτίου (5%), Ανθεκτικό σε Συγκολλήσεις, Δεξιάς Κοπής N, Κωνικό: 135°, Ανοχής H8

Κατάλληλα για Ανοξειδωτο Ατσάλι

410167071063237	410167071063251	410167071063268	410167071063282	410167071063305	135°	ROSTFREI	
Ø 10mm	Ø 10,5mm	Ø 11mm	Ø 12mm	Ø 13mm			
307/301/000 (608)	307/301/050 (607)	307/301/100 (606)	307/301/200 (605)	307/301/300 (604)			

KEIL HSS-E DIN 338 Cobalt, Ground, Split Point 307 Bits in Pouch

SET Τρυπάνια (αρίδες) Μετάλλου σε Θήκη, 19 τεμ. Ø 1 - 10 / 0,5 mm Υψηλής Ταχύτητας, Κοβαλτίου (5%), Ανθεκτικό, Δεξιάς Κοπής N, Κωνικό: 135°, Ανοχής H8

KEIL HSS-E DIN 338 Cobalt Ground Split Point, 19ps, 307.501.110 (690)

SET Τρυπάνια (αρίδες) Μετάλλου σε Θήκη, 25 τεμ. Ø 1 - 13 / 0,5 mm Υψηλής Ταχύτητας, Κοβαλτίου (5%), Ανθεκτικό, Δεξιάς Κοπής N, Κωνικό: 135°, Ανοχής H8

KEIL HSS-E DIN 338 Cobalt Ground Split Point, 25ps, 307.501.113 (687)

SET Τρυπάνια (αρίδες) Μετάλλου σε Θήκη, 5 τεμ. Ø 4, 5, 6, 8, 10 mm

KEIL HSS-G Speeder DIN 338 RN Metal Drill Bit, 5ps, 312.350.410 (698)



UNIT Τρυπάνια (αρίδες) Μετάλλου, Υψηλής Ταχύτητας, Κοβαλτίου (5%), Ανθεκτικό σε Συγκολλήσεις, Δεξιάς Κοπής N, Κωνικό: 135°, Ανοχής H8. Κατάλληλα για Ανοξειδωτο Ατσάλι



x10	x10	x10	x10	x10	x10	x10
Ø 1mm	Ø 2mm	Ø 2,5mm	Ø 3mm	Ø 3,5mm	Ø 4mm	Ø 4,5mm
307/000/100 (135)	307/000/200 (134)	307/000/250 (133)	307/000/300 (132)	307/000/350 (131)	307/000/400 (130)	307/000/450 (129)



KEIL HSS-E DIN 338 Cobalt, Ground, Split Point 307 Bits in a Box

Τρυπάνια (αρίδες) Μετάλλου, Υψηλής Ταχύτητας, Κοβαλτίου (5%), Ανθεκτικό σε Συγκολλήσεις, Δεξιάς Κοπής N, Κωνικό: 135°, Ανοχής H8. Κατάλληλα για Ανοξειδωτο Ατσάλι



x10	x10	x10	x10	x10	x10	x10	x10	x10
Ø 5mm	Ø 5,5mm	Ø 6mm	Ø 6,5mm	Ø 7mm	Ø 7,5mm	Ø 8mm	Ø 8,5mm	Ø 9mm
307/000/500 (128)	307/000/550 (127)	307/000/600 (126)	307/000/650 (125)	307/000/700 (534)	307/000/750 (535)	307/000/800 (124)	307/000/850 (123)	307/000/900 (122)

KEIL HSS-E DIN 338 Cobalt, Ground, Split Point 307 Bits in a Box

UNIT Τρυπάνια (αρίδες) Μετάλλου, Υψηλής Ταχύτητας, Κοβαλτίου (5%), Ανθεκτικό σε Συγκολλήσεις, Δεξιάς Κοπής N, Κωνικό: 135°, Ανοχής H8. Κατάλληλα για Ανοξειδωτο Ατσάλι



x10	x10	x5	x5	x5
Ø 9,5mm	Ø 10mm	Ø 11mm	Ø 12mm	Ø 13mm
307/000/950 (121)	307/001/000 (120)	307/001/100 (119)	307/001/200 (118)	307/001/300 (117)



KEIL HSS-E DIN 338 Cobalt, Ground, Split Point 307 Bits in a Box

SET Τρυπάνια (αρίδες) Μετάλλου σε Θήκη, 5 τεμ. Ø 4, 5, 6, 8, 10mm Υψηλής Ταχύτητας, Κοβαλτίου (5%), Ανθεκτικό, Δεξιάς Κοπής N, Κωνικό: 135°, Ανοχής H8

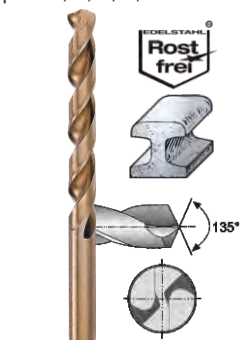

KEIL HSS-E DIN 338 Cobalt Ground Split Point, 5ps, 307.350.410 (810)

SET Τρυπάνια (αρίδες) Μετάλλου 4,1mm, Διπλής Όψης, Υψηλής Ταχύτητας & Απόδοσης Χάλυβας, Ανοχής H8, DIN 1412 C

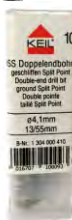
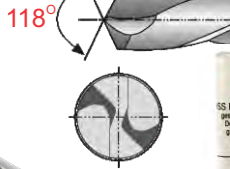

KEIL HSS Double-End Bit, Ground, Split Point 304/000/410 (521)

UNIT Χαράκτης (μολύβι) για Σημάδεμα σε Μέταλλο, με Άκρη Καρβιδίου, Επιχρωμιωμένη Επιφάνεια



KEIL Scriber Shank Ø6 140mm 140.140.060 (661)



UNIT Τρυπάνια (αρίδες) Μετάλλου **Μόρσο**, για τρυπάνι Πάγκου. Υψηλής Ταχύτητας & Απόδοσης Χάλυβας, Δεξιάς Κοπής N, Κωνικό: 118°, Ανοχής H8

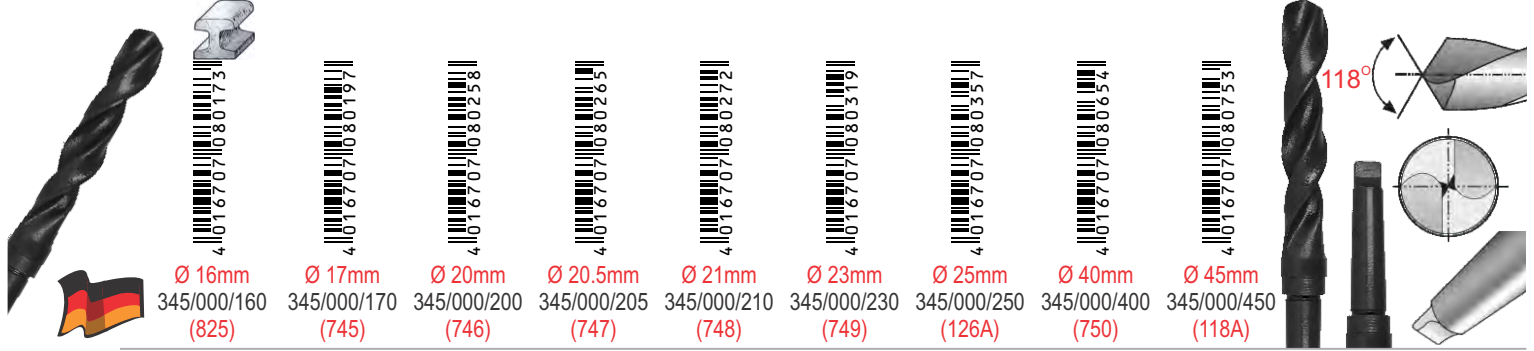

410167071080173	410167071080171	410167071080258	410167071080265	410167071080272	410167071080319	410167071080357	410167071080654	410167071080753
Ø 16mm	Ø 17mm	Ø 20mm	Ø 20.5mm	Ø 21mm	Ø 23mm	Ø 25mm	Ø 40mm	Ø 45mm
345/000/160 (825)	345/000/170 (745)	345/000/200 (746)	345/000/205 (747)	345/000/210 (748)	345/000/230 (749)	345/000/250 (126A)	345/000/400 (750)	345/000/450 (118A)

KEIL HSS Morse Taper 345

UNIT Αυτοδιάτρητο Κολαούζο, Υψηλής Ταχύτητας, Υψηλής Απόδοσης Χάλυβας, Ανοίγει Τρύπα και Δημιουργεί Σπείρωμα με μία Κίνηση. Up to max. 600 N/mm², 1/4 "bit drive DIN 3126 - C 6.3

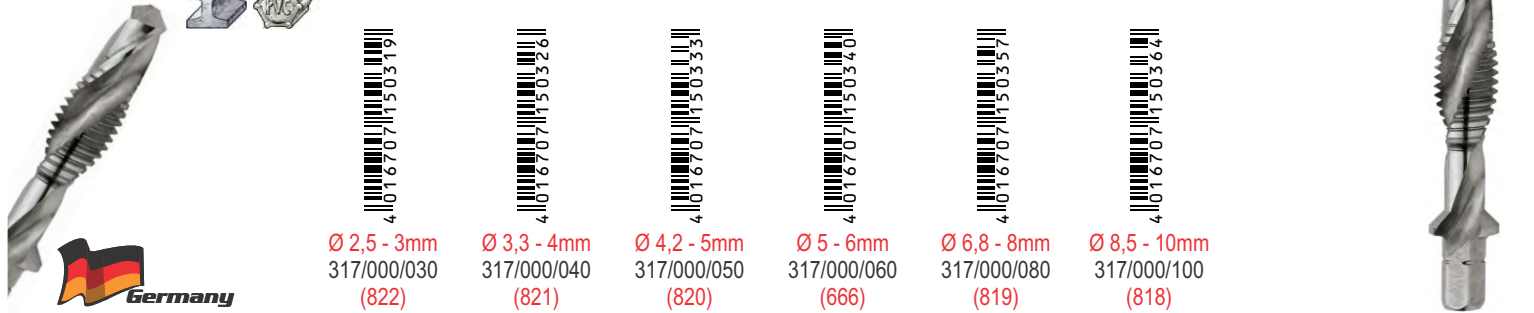

410167071450319	410167071450326	410167071450333	410167071450340	410167071450357	410167071450364
Ø 2,5 - 3mm	Ø 3,3 - 4mm	Ø 4,2 - 5mm	Ø 5 - 6mm	Ø 6,8 - 8mm	Ø 8,5 - 10mm
317/000/030 (822)	317/000/040 (821)	317/000/050 (820)	317/000/060 (666)	317/000/080 (819)	317/000/100 (818)

KEIL HSS Combination Tool KEILBIT 317

UNIT Φρέζα Τρυπάνι Ξύλου, Μετάλλου και Πλαστικού, Υψηλής Απόδοσης Χάλυβας, Δεξιάς Τριπλής Κοπής. 1/4 "bit drive DIN 3126 - C 6.3

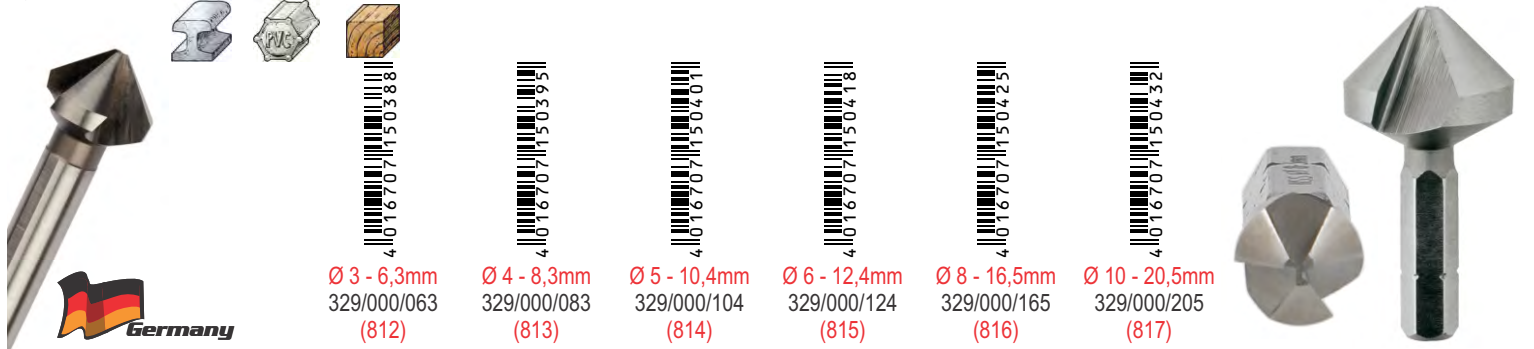

410167071450388	410167071450395	410167071450401	410167071450418	410167071450425	410167071450432
Ø 3 - 6,3mm	Ø 4 - 8,3mm	Ø 5 - 10,4mm	Ø 6 - 12,4mm	Ø 8 - 16,5mm	Ø 10 - 20,5mm
329/000/063 (812)	329/000/083 (813)	329/000/104 (814)	329/000/124 (815)	329/000/165 (816)	329/000/205 (817)

KEIL HSS Countersink 90°, KEILBIT 329

UNIT Βηματικά Τρυπάνια (αρίδες) Μετάλλου και Πλαστικού, Υψηλής Απόδοσης Χάλυβας, Δεξιάς Διπλής Κοπής

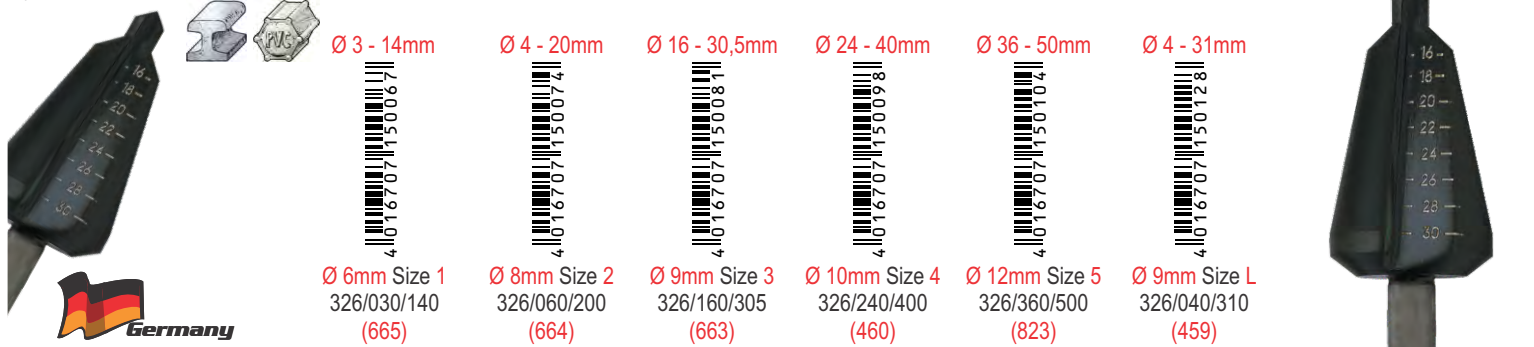

410167071450067	410167071450074	410167071450081	410167071450098	410167071450104	410167071450128
Ø 6mm Size 1	Ø 8mm Size 2	Ø 9mm Size 3	Ø 10mm Size 4	Ø 12mm Size 5	Ø 9mm Size L
326/030/140 (665)	326/060/200 (664)	326/160/305 (663)	326/240/400 (460)	326/360/500 (823)	326/040/310 (459)

KEIL HSS Tube & Sheet Drill, Shank 326

UNIT Βηματικά Τρυπάνια (αρίδες) Μετάλλου και Πλαστικού, Υψηλής Απόδοσης Χάλυβας

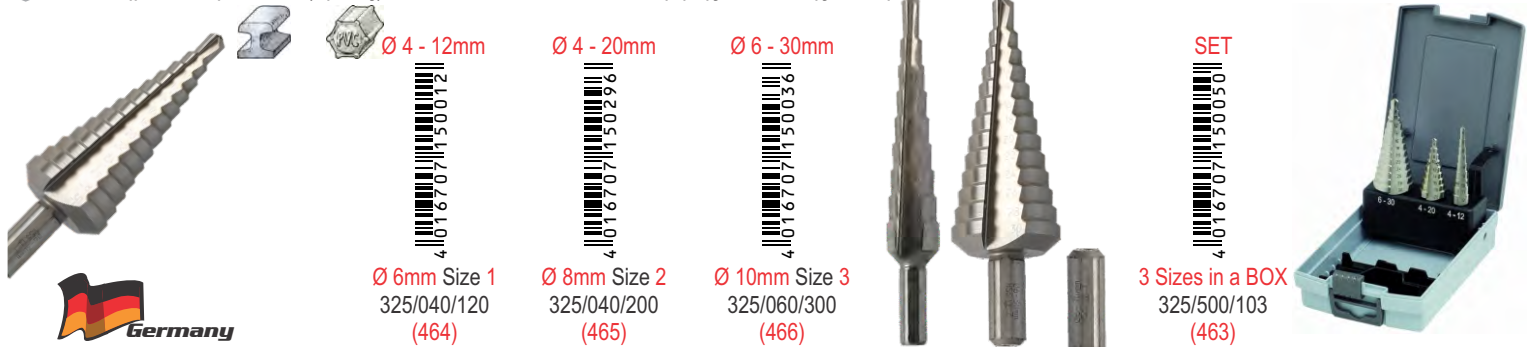

410167071450012	410167071450298	410167071450036	410167071450050
Ø 4 - 12mm	Ø 4 - 20mm	Ø 6 - 30mm	SET 3 Sizes in a BOX
Ø 6mm Size 1 325/040/120 (464)	Ø 8mm Size 2 325/040/200 (465)	Ø 10mm Size 3 325/060/300 (466)	325/500/103 (463)

KEIL HSS Step Drills, Shank 325

KEIL HSS Step Drills, 3 pcs



UNIT Τρυπάνια (αρίδες) Μπετού, με Μύτη Καρβιδίου, Σφυρηλατημένος Χάλυβας, ISO 5468, Γκρι Επιφάνεια, Κατάλληλο για Σιδηροσυνδέσεις



Germany

Ø 5mm	Ø 5mm	Ø 5mm	Ø 5mm	Ø 5mm	Ø 5mm	Ø 5,5mm	Ø 5,5mm	Ø 5,5mm	Ø 6mm
253/050/110 (1)	253/050/160 (2)	253/050/210 (3)	253/050/260 (4)	253/050/310 (5)	253/055/260 (6)	253/055/110 (9)	253/055/160 (7)	253/055/160 (7)	253/060/110 (8)

KEIL Hammer Drill Bit SDS-plus MS5 TURBOKEIL 253

UNIT Τρυπάνια (αρίδες) Μπετού, με Μύτη Καρβιδίου, Σφυρηλατημένος Χάλυβας, ISO 5468, Γκρι Επιφάνεια, Κατάλληλο για Σιδηροσυνδέσεις

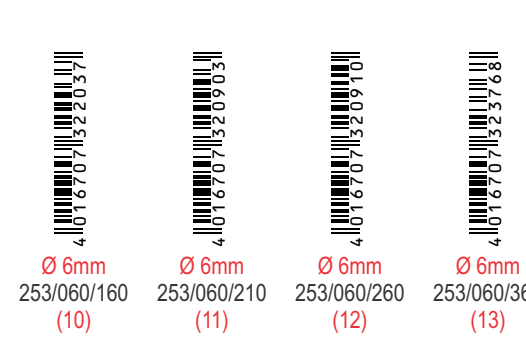

Ø 6mm	Ø 6mm	Ø 6mm	Ø 6mm	Ø 6mm	Ø 6,5mm	Ø 6,5mm	Ø 6,5mm	Ø 6,5mm	Ø 7mm	Ø 7mm
253/060/160 (10)	253/060/210 (11)	253/060/260 (12)	253/060/360 (13)	253/060/460 (14)	253/065/110 (15)	253/065/160 (16)	253/065/210 (17)	253/065/260 (18)	253/070/110 (212)	253/070/160 (211)

KEIL Hammer Drill Bit SDS-plus MS5 TURBOKEIL 253

UNIT Τρυπάνια (αρίδες) Μπετού, με Μύτη Καρβιδίου, Σφυρηλατημένος Χάλυβας, ISO 5468, Γκρι Επιφάνεια, Κατάλληλο για Σιδηροσυνδέσεις

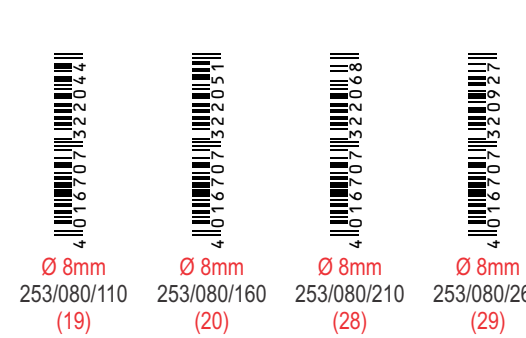

Ø 8mm	Ø 8mm	Ø 8mm	Ø 8mm	Ø 8mm	Ø 8mm	Ø 9mm	Ø 10mm	Ø 10mm	Ø 10mm	Ø 10mm
253/080/110 (19)	253/080/160 (20)	253/080/210 (28)	253/080/260 (29)	253/080/310 (210)	253/080/460 (53)	253/090/160 (30)	253/100/110 (31)	253/100/160 (32)	253/100/210 (33)	253/100/260 (34)

KEIL Hammer Drill Bit SDS-plus MS5 TURBOKEIL 253

UNIT Τρυπάνια (αρίδες) Μπετού, με Μύτη Καρβιδίου, Σφυρηλατημένος Χάλυβας, ISO 5468, Γκρι Επιφάνεια, Κατάλληλο για Σιδηροσυνδέσεις

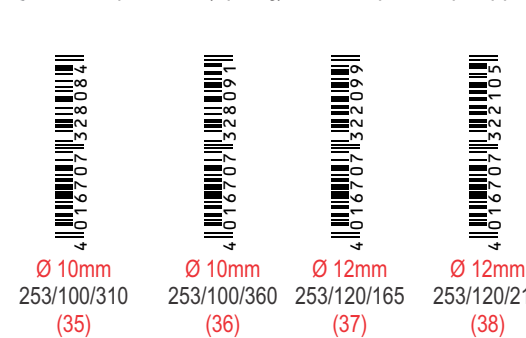

Ø 10mm	Ø 10mm	Ø 12mm	Ø 12mm	Ø 12mm	Ø 12mm	Ø 12mm	Ø 13mm	Ø 14mm	Ø 14mm	Ø 14mm
253/100/310 (35)	253/100/360 (36)	253/120/165 (37)	253/120/215 (38)	253/120/265 (39)	253/120/450 (57)	253/120/600 (58)	253/130/160 (40)	253/140/165 (41)	253/140/215 (42)	253/140/265 (43)

KEIL Hammer Drill Bit SDS-plus MS5 TURBOKEIL 253

UNIT Τρυπάνια (αρίδες) Μπετού, με Μύτη Καρβιδίου, Σφυρηλατημένος Χάλυβας, ISO 5468, Γκρι Επιφάνεια, Κατάλληλο για Σιδηροσυνδέσεις

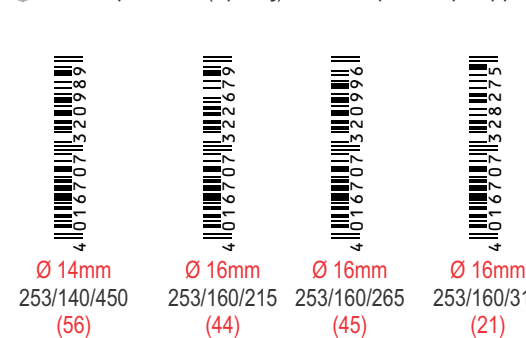

Ø 14mm	Ø 16mm	Ø 16mm	Ø 16mm	Ø 16mm	Ø 17mm	Ø 18mm	Ø 18mm	Ø 20mm	Ø 20mm	Ø 20mm
253/140/450 (56)	253/160/215 (44)	253/160/265 (45)	253/160/310 (21)	253/160/450 (22)	253/170/200 (23)	253/180/200 (24)	253/180/300 (25)	253/200/300 (26)	253/200/200 (27)	253/200/450 (55)

KEIL Hammer Drill Bit SDS-plus MS5 TURBOKEIL 253

UNIT Τρυπάνια (αρίδες) Μπετού, με Μύτη Καρβιδίου, Σφρηλατημένος Χάλυβας, ISO 5468, Γκρι Επιφάνεια, Κατάλληλο για Σιδηροσυνδέσεις

410167071323348	410167071323355	410167071323379	410167071323386	410167071323980	410167071323416	410167071323423	
Ø 22mm 253/220/250 (47)	Ø 22mm 253/220/450 (50)	Ø 24mm 253/240/250 (48)	Ø 24mm 253/240/450 (51)	Ø 26mm 253/260/160 (46)	Ø 26mm 253/260/250 (49)	Ø 26mm 253/260/450 (52)	

Germany

KEIL Hammer Drill Bit SDS-plus MS5 TURBOKEIL 253

UNIT Τρυπάνια (αρίδες) Μπετού, με Μύτη Καρβιδίου, Σφρηλατημένος Χάλυβας, ISO 5468, Γκρι Επιφάνεια, Κατάλληλο για Σιδηροσυνδέσεις

410167071290015	410167071290022	410167071290039	410167071290046	410167071290053	410167071290077	410167071290084	410167071290091	410167071290107
Ø 4mm 000/040 (444)	Ø 5mm 000/50 (445)	Ø 6mm 000/60 (446)	Ø 7mm 000/70 (447)	Ø 8mm 000/80 (448)	Ø 10mm 000/100 (449)	Ø 12mm 000/120 (450)	Ø 14mm 000/140 (451)	Ø 16mm 000/160 (452)

Germany

KEIL Concrete Drill Bit MS5 TURBOKEIL 258

UNIT Τρυπάνια (αρίδες) Μπετού, από Σφρηλατημένο Χάλυβα Χρωμίου, Νικελίου, Μολυβδαινίου, X-Shape με 4 Κόφτες, για Σιδηροσυνδέσεις

410167071360114	410167071360121	410167071360138	410167071360367	410167071360145	410167071360152	410167071360176	410167071360183	410167071360206
Ø 22mm 270/200/320 (716)	Ø 22mm 270/220/520 (707)	Ø 24mm 270/240/320 (715)	Ø 24mm 270/240/520 (737)	Ø 25mm 270/250/320 (714)	Ø 25mm 270/250/520 (706)	Ø 28mm 270/280/370 (713)	Ø 28mm 270/280/570 (705)	Ø 30mm 270/300/570 (704)

Germany

KEIL SDS-Max W2 TURBOKEIL X-Shape 270

UNIT Τρυπάνια (αρίδες) Μπετού, από Σφρηλατημένο Χάλυβα Χρωμίου, Νικελίου, Μολυβδαινίου, X-Shape με 4 Κόφτες, για Σιδηροσυνδέσεις









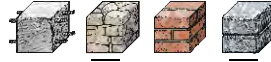

410167071360220	410167071360251	410167071360299
Ø 32mm 270/320/570 (703)	Ø 35mm 270/350/570 (702)	Ø 40mm 270/400/570 (701)

Germany

KEIL SDS-Max W2 TURBOKEIL X-Shape 270



UNIT Τρυπάνια (αρίδες) Μπετού, Σφρηλατημένος Χάλυβας Χρωμίου, Νικελίου, Μολυβδαινίου, ISO 5468, Χρο Κεφαλή με 4 Κοπές

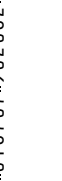

















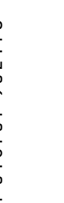





Germany

Ø 5mm	Ø 5mm	Ø 5mm	Ø 5,5mm	Ø 5,5mm	Ø 6mm	Ø 6mm	Ø 6mm	Ø 6mm	Ø 6mm
251/050/110	251/050/160	251/050/210	251/055/160	251/055/210	251/060/110	251/060/160	251/060/210	251/060/210	251/060/260
(259)	(258)	(238)	(239)	(237)	(257)	(256)	(241)		(232)

KEIL Hammer Drill Bit SDS-plus MS5 Xpro TURBOHEAD 251













UNIT Τρυπάνια (αρίδες) Μπετού, Σφρηλατημένος Χάλυβας Χρωμίου, Νικελίου, Μολυβδαινίου, ISO 5468, Χρο Κεφαλή με 4 Κοπές

Ø 8mm	Ø 8mm	Ø 8mm	Ø 8mm	Ø 8mm	Ø 10mm	Ø 10mm	Ø 10mm	Ø 10mm	Ø 10mm	Ø 12mm
251/080/110	251/080/160	251/080/210	251/080/260	251/080/310	251/100/160	251/100/210	251/100/260	251/100/310	251/100/360	251/120/160
(255)	(254)	(253)	(252)	(235)	(251)	(250)	(249)	(236)	(231)	(248)

KEIL Hammer Drill Bit SDS-plus MS5 Xpro TURBOHEAD 251

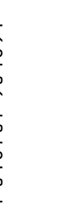









UNIT Τρυπάνια (αρίδες) Μπετού, Σφρηλατημένος Χάλυβας Χρωμίου, Νικελίου, Μολυβδαινίου, ISO 5468, Χρο Κεφαλή με 4 Κοπές

Ø 12mm	Ø 12mm	Ø 12mm	Ø 12mm	Ø 14mm	Ø 14mm	Ø 14mm	Ø 14mm	Ø 14mm	Ø 16mm	Ø 16mm
251/120/210	251/120/260	251/120/450	251/120/600	251/140/160	251/140/210	251/140/260	251/140/310	251/140/450	251/160/210	251/160/260
(247)	(246)	(229)	(224)	(243)	(242)	(244)	(233)	(230)	(240)	(234)

KEIL Hammer Drill Bit SDS-plus MS5 Xpro TURBOHEAD 251

UNIT Τρυπάνια (αρίδες) Μπετού, Σφρηλατημένος Χάλυβας Χρωμίου, Νικελίου, Μολυβδαινίου, ISO 5468, Χρο Κεφαλή με 4 Κοπές















Germany



Ø 16mm	Ø 18mm	Ø 18mm	Ø 20mm	Ø 20mm	Ø 20mm
251/160/450	251/180/250	251/180/450	251/200/250	251/200/450	251/200/600
(228)	(245)	(226)	(213)	(227)	(225)

KEIL Hammer Drill Bit SDS-plus MS5 Xpro TURBOHEAD 251

UNIT Τρυπάνια (αρίδες) Μπετού, Σφρηλατημένος Χάλυβας Χρωμίου, Νικελίου, Μολυβδαινίου, ISO 5468, Χρο Κεφαλή με 4 Κοπές







Germany

Ø 5mm	Ø 6mm	Ø 8mm	Ø 10mm	Ø 12mm	Ø 14mm
238/000/050	238/000/060	238/000/080	238/000/100	238/000/120	238/000/140
(453)	(454)	(455)	(456)	(457)	(458)

KEIL Concrete Drill Bit MS5 TURBOHEAD Xpro 238

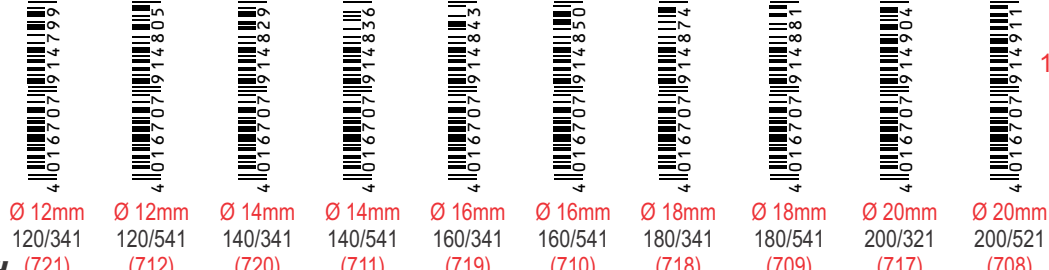
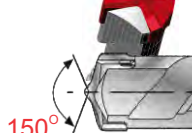



UNIT Τρυπάνια (αρίδες) Μπετού, Σφρηλατημένος Χάλυβας Χρωμίου, Νικελίου, Μολυβδαινίου, ISO 5468, Χρσο Κεφαλή με 4 Κοπές

Ø 12mm	Ø 12mm	Ø 14mm	Ø 14mm	Ø 16mm	Ø 16mm	Ø 18mm	Ø 18mm	Ø 20mm	Ø 20mm
120/341	120/541	140/341	140/541	160/341	160/541	180/341	180/541	200/321	200/521
(721)	(712)	(720)	(711)	(719)	(710)	(718)	(709)	(717)	(708)

KEIL Hammer Drill Bit SDS-Max W2 TURBOHEAD Χρσο 270



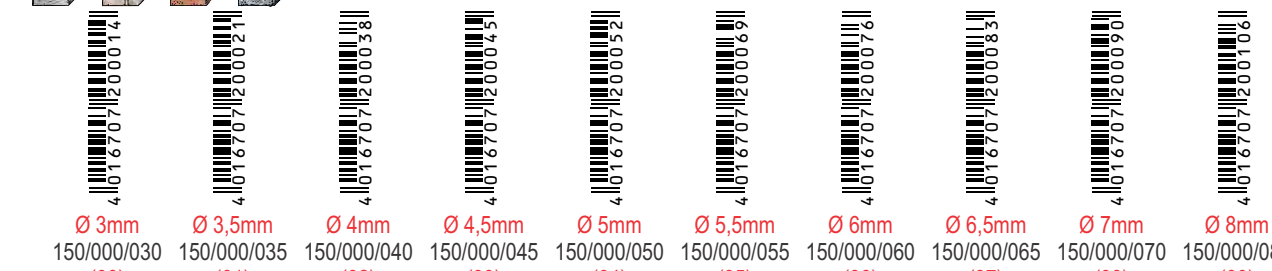

UNIT Τρυπάνια (αρίδες) Μπετού, με Μύτη Καρβιδίου, Σφρηλατημένος Χάλυβας, για Κρουστικά, ISO 5468

Ø 3mm	Ø 3,5mm	Ø 4mm	Ø 4,5mm	Ø 5mm	Ø 5,5mm	Ø 6mm	Ø 6,5mm	Ø 7mm	Ø 8mm
150/000/030	150/000/035	150/000/040	150/000/045	150/000/050	150/000/055	150/000/060	150/000/065	150/000/070	150/000/080
(80)	(81)	(82)	(83)	(84)	(85)	(86)	(87)	(88)	(89)

KEIL Percussion Drill Bit KEILER 150

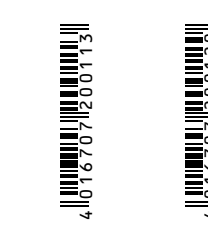

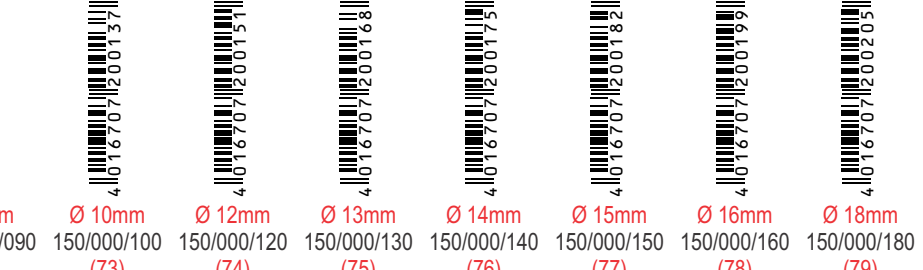

Τρυπάνια (αρίδες) Μπετού, με Μύτη Καρβιδίου, Σφρηλατημένος Χάλυβας, για Κρουστικά, ISO 5468

Ø 8,5mm	Ø 9mm	Ø 10mm	Ø 12mm	Ø 13mm	Ø 14mm	Ø 15mm	Ø 16mm	Ø 18mm
150/000/085	150/000/090	150/000/100	150/000/120	150/000/130	150/000/140	150/000/150	150/000/160	150/000/180
(71)	(72)	(73)	(74)	(75)	(76)	(77)	(78)	(79)

KEIL Percussion Drill Bit KEILER 150



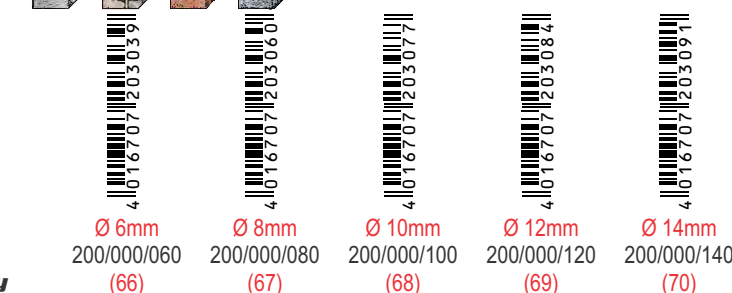
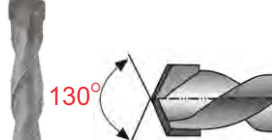

UNIT Τρυπάνια (αρίδες) Μπετού, με Μύτη Καρβιδίου, Σφρηλατημένος Χάλυβας, για Κρουστικά, ISO 5468

Ø 6mm	Ø 8mm	Ø 10mm	Ø 12mm	Ø 14mm
200/000/060	200/000/080	200/000/100	200/000/120	200/000/140
(66)	(67)	(68)	(69)	(70)

KEIL Percussion Drill Bit KEILER Long 200

UNIT Τρυπάνια (αρίδες) Μπετού, με Μύτη Καρβιδίου, Σφρηλατημένος Χάλυβας, για Κρουστικά, ISO 5468

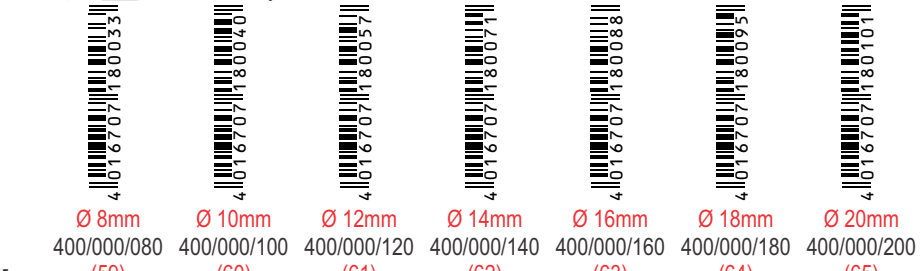
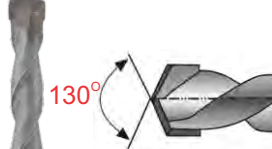





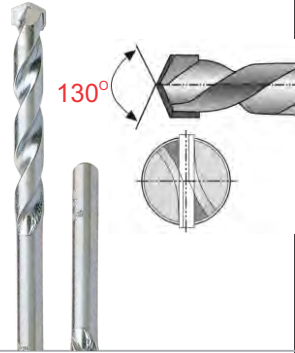

Ø 8mm	Ø 10mm	Ø 12mm	Ø 14mm	Ø 16mm	Ø 18mm	Ø 20mm
400/000/080	400/000/100	400/000/120	400/000/140	400/000/160	400/000/180	400/000/200
(59)	(60)	(61)	(62)	(63)	(64)	(65)

KEIL Percussion Drill Bit KEILER Extra Long 400



SET Τρυπάνια (αρίδες) Μπετού και Σκληρών Υλικών, Σφυρηλατημένος Χάλυβας, Ειδική Αιχμή Καρβιδίου, Χρωμιωμένα, Υψηλής Ταχύτητας 4, 5, 6, 8, 10mm



KEIL MultiPack Masonry Drill Bit OPAL, 190.350.410, 5 pcs (807)

SET Τρυπάνια (αρίδες) Μπετού, 10 τεμ. Ø 6 x 100/160 mm

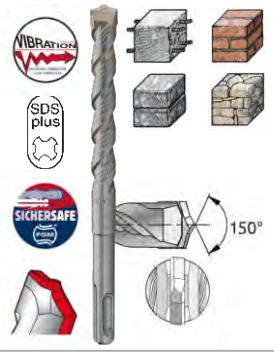

KEIL SDS-PLUS MS5 TURBOKEIL, 10ps, 253.960.165 (519)

SET Τρυπάνια (αρίδες) Μπετού, 10 τεμ. Ø 10 x 100/160 mm

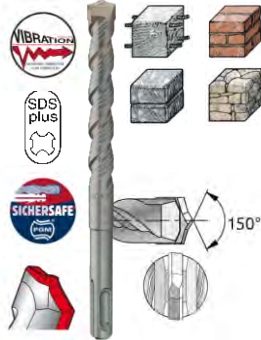

KEIL SDS-PLUS MS5 TURBOKEIL, 10ps, 253.900.160 (517)

SET Τρυπάνια (αρίδες) Μπετού, 10 τεμ. Ø 12 x 100/160 mm

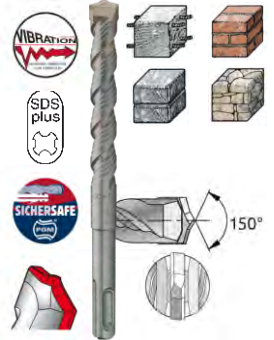

KEIL SDS-PLUS MS5 TURBOKEIL, 10ps, 253.920.165 (512)

SET Τρυπάνια (αρίδες) Μπετού, 5 τεμ. Ø 14 x 100/160 mm

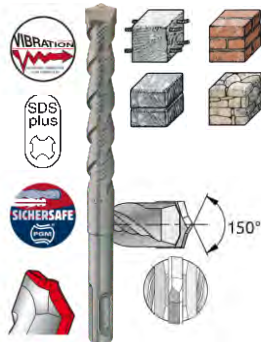

KEIL SDS-PLUS MS5 TURBOKEIL, 5ps, 253.940.165 (513)

SET Τρυπάνια (αρίδες) Μπετού, με Μύτη Καρβιδίου, Σφυρηλατημένος Χάλυβας, ISO 5468, Κατάλληλο για Σιδηροσυνδέσεις Ø5x110, Ø6x110, Ø6x160, Ø8x160, Ø10x160



KEIL Hammer Drill MS5 TURBOKEIL, SET 5pcs, 253.350.510 (699)

SET Τρυπάνια (αρίδες) Μπετού, 10 τεμ. Ø 10 x 100/160 mm

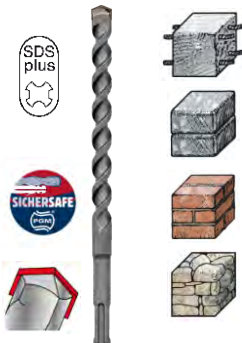

KEIL SDS-PLUS KEILRAPID, 10ps, 256.900.160 (514)

SET Τρυπάνια (αρίδες) Μπετού, 10 τεμ. Ø 8 x 100/160 mm



KEIL SDS-PLUS KEILRAPID, 10ps, 256.980.160 (515)

SET Τρυπάνια (αρίδες) Μπετού, Σφυρηλατημένος Χάλυβας Χρωμίου, Νικελίου, Μολυβδαινίου, ISO 5468, Χρσο Κεφαλή με 4 Κοπές Ø5x110, Ø6x110, Ø6x160, Ø8x160, Ø10x160,

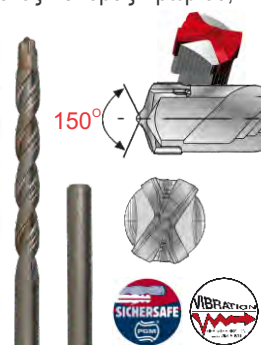

KEIL Hammer Drill MS5 Xpro TURBOHEAD, 5pcs, 251.350.510 (700)

SET Τρυπάνια (αρίδες) Μπετού, με Μύτη Καρβιδίου, Σφυρηλατημένος Χάλυβας, για Κρουστικά, ISO 5468 Ø4, 5, 6, 8, 10mm

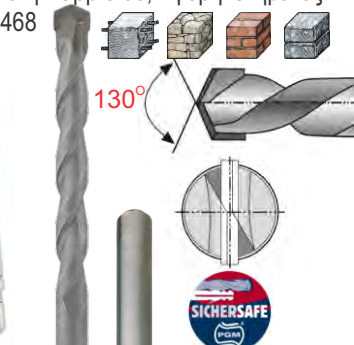

KEIL Percussion Drill Bit KEILER, 5 pcs, 150.350.410 (696)



UNIT Καλέμια από Σφυρήλατο Ατσάλι Υψηλής Ποιότητας

NEW

CGW
SDS-Plus
Point Chisel
2501

7 12961661803484

250mm
803484

SDS plus

CGW SDS-Plus Point Chisel 803484 (837)

UNIT Καλέμια από Σφυρήλατο Ατσάλι Υψηλής Ποιότητας

NEW

CGW
SDS-Plus
Flat Chisel
2501

7 12961661803507

20x250mm
803507

SDS plus

CGW SDS-Plus Flat Chisel 803507 (838)

UNIT Καλέμια από Σφυρήλατο Ατσάλι Υψηλής Ποιότητας

4 101670712600491

4 101670712600561

Germany

25x280mm
503/125/280
(108)

25x400mm
503/125/400
(109)

fit in SDS max TE-Y

KEIL SDS-Max Flat Chisel 503

UNIT Καλέμια από Σφυρήλατο Ατσάλι Υψηλής Ποιότητας

4 101670712602641

4 101670712601311

Germany

20x140mm
502/120/140
(314)

20x250mm
502/120/250
(110)

SDS plus

KEIL SDS-Plus Flat Chisel 502

UNIT Καλέμια από Σφυρήλατο Ατσάλι Υψηλής Ποιότητας

4 101670712600181

4 101670712600251

Germany

280mm
503/000/280
(741)

400mm
503/000/400
(112)

fit in SDS max TE-Y

KEIL SDS-Max Point Chisel 503

UNIT Καλέμια από Σφυρήλατο Ατσάλι Υψηλής Ποιότητας

4 101670712602541

4 101670712601001

Germany

140mm
502/000/140
(315)

250mm
502/000/251
(316)

SDS plus

KEIL SDS-Plus Point Chisel 502

UNIT Καλέμια από Σφυρήλατο Ατσάλι Υψηλής Ποιότητας

4 101670712601931

Germany

50x300mm
503/550/300
(313)

fit in SDS max TE-Y

KEIL SDS-Max Tile Chisel 503/550/300 (313)

UNIT Καλέμια από Σφυρήλατο Ατσάλι Υψηλής Ποιότητας

4 101670712601621

Germany

40x200mm
502/540/200
(114)

SDS plus

KEIL SDS-Plus Tile Chisel 502 (114)

UNIT Καλέμια από Σφυρήλατο Ατσάλι Υψηλής Ποιότητας

4 101670712600941

Germany

26x300mm
503/326/300
(115)

fit in SDS max TE-Y

KEIL SDS-Max Hollow Chisel 503/326/300 (115)

UNIT Καλέμια από Σφυρήλατο Ατσάλι Υψηλής Ποιότητας

4 101670712601551

Germany

22x250mm
502/322/250
(312)

SDS plus

KEIL SDS-Plus Hollow Chisel 502/322/250 (312)



UNIT Καλέμια από Σφυρήλατο Ατσάλι Υψηλής Ποιότητας

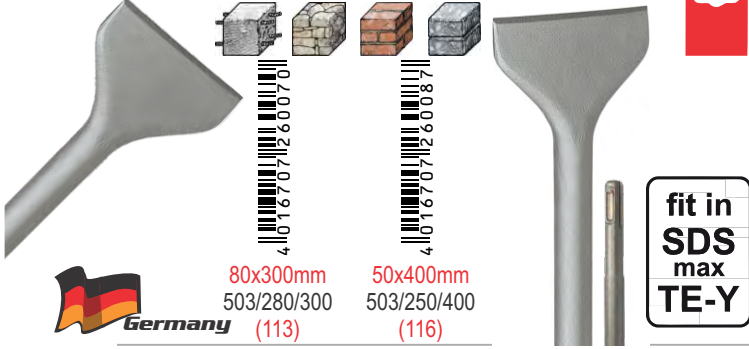

fit in SDS max TE-Y

80x300mm
503/280/300
Germany (113)

50x400mm
503/250/400
Germany (116)

KEIL SDS-Max Spade Chisel 503

UNIT Καλέμια από Σφυρήλατο Ατσάλι Υψηλής Ποιότητας

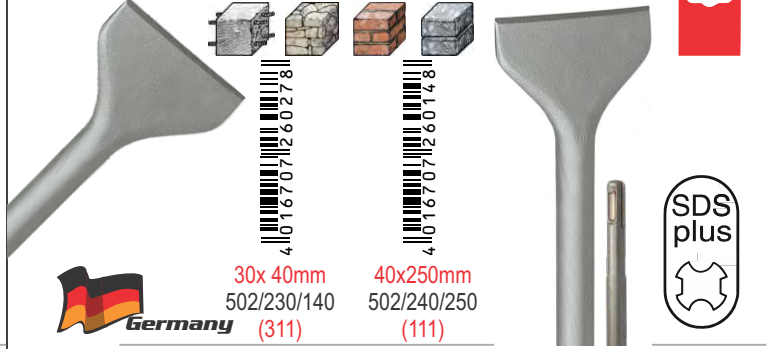

SDS plus

30x 40mm
502/230/140
Germany (311)

40x250mm
502/240/250
Germany (111)

KEIL SDS-Plus Spade Chisel 502

UNIT Καλέμια από Σφυρήλατο Ατσάλι Υψηλής Ποιότητας

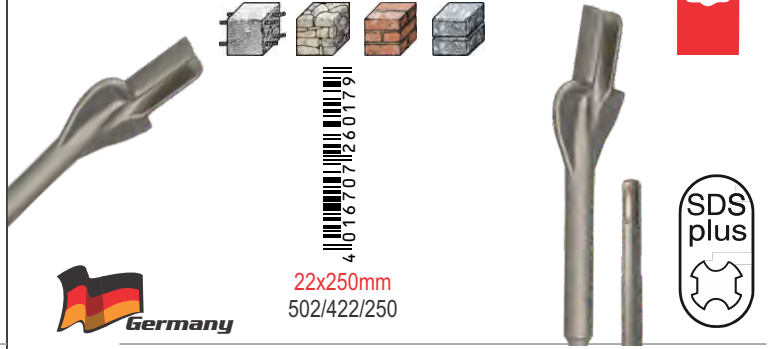

SDS plus

22x250mm
502/422/250
Germany (740)

KEIL SDS-Plus Channel Chisel - Hilti TE-C 502.422.250 (740)

SET Καλέμια SDS Plus, 25cm, για Κρουστικά, 3τεμ



SDS plus

CGW Chisel SDS-PLUS, 803460 (839)

SET Τρυπάνια (αρίδες) Μπετού, 4 τεμ. Ø 12, 14, 16, 20 x 450 mm

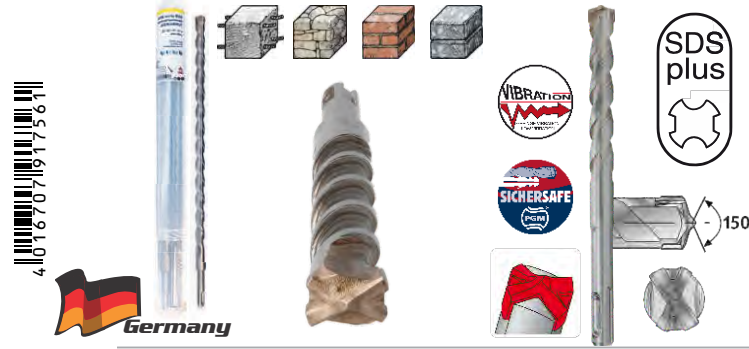

SDS plus

150°

KEIL SDS-PLUS MS5 TURBOHEAD XPRO - 251.246.450 (722)

SET Τρυπάνια (αρίδες) Μπετού, 4 τεμ. Ø 12, 14, 16, 20 x 450 mm



SDS plus

150°

KEIL SDS-PLUS MS5 TURBOKEIL - 253.246.450 (723)

SET Τρυπάνια (αρίδες) Μπετού, 4 τεμ. Ø 12, 14, 16, 20 x 450 mm



SDS plus

KEIL SDS-PLUS KEILRAPID - 256.246.450 (724)



UNIT Μύτη Τρυπανιού, από Χάλυβα Χρωμίου-Νικελίου-Μολυβδαινίου. Καρφιδικά καρφιά ανθεκτικά στη φθορά (τύπος S), Ενισχυμένα στην επιφάνεια με Καρβίδιο.

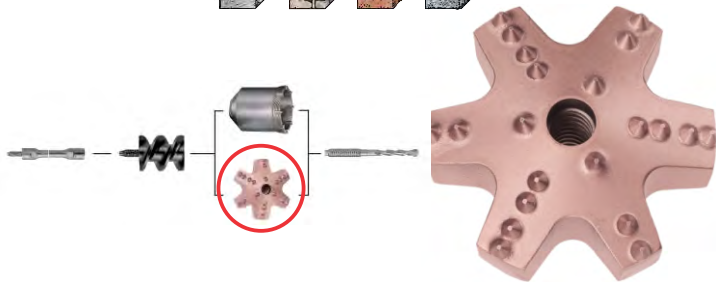

55mm 000/055 (143)	65mm 000/065 (117A)	80mm 000/080 (538)	110mm 000/110 (536)



KEIL Break-Through Core Drill Bit with RATIO 259

UNIT Κεντρικό Τρυπάνι για Break-Through Core Drill Bit RATIO, 16x124mm

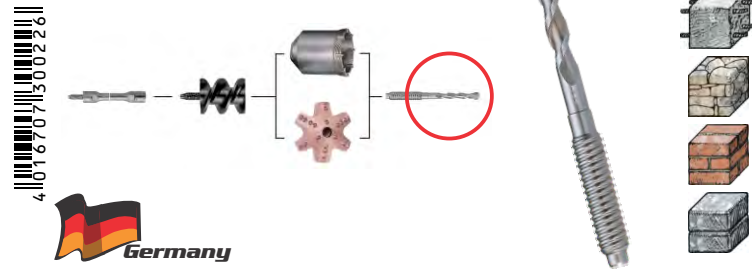

4 101 670 713 002 261



UNIT Ελικοειδές Κοπή για Break-Through Core Drill Bit RATIO

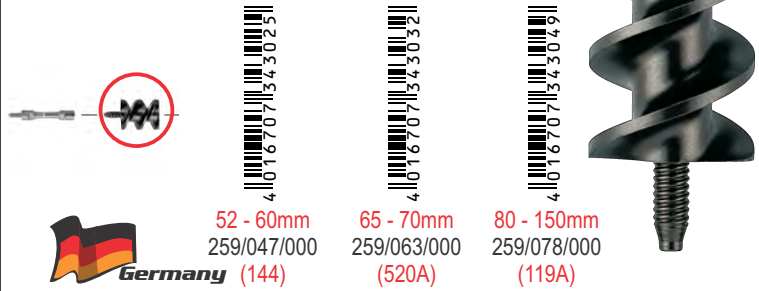

52 - 60mm 259/047/000 (144)	65 - 70mm 259/063/000 (520A)	80 - 150mm 259/078/000 (119A)



KEIL Centre Drill Bit with RATIO 259.160.124 (669)

UNIT Αντάπτορας Τρυπανιού για Break-Through Core Drill Bit RATIO

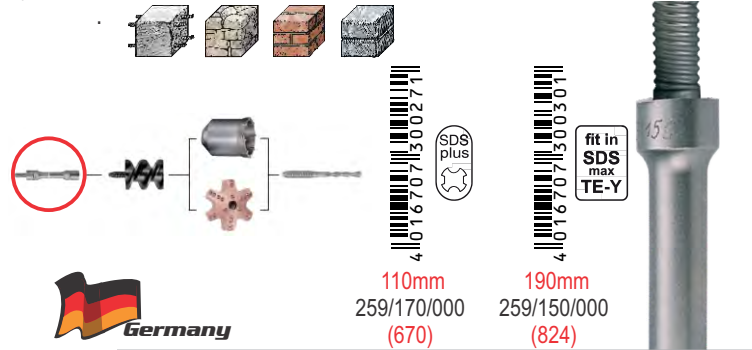

110mm 259/170/000 (670)	190mm 259/150/000 (824)



KEIL Cutting Helix 259

UNIT Επέκταση Αντάπτορα Τρυπανιού για Break-Through Core Drill Bit RATIO

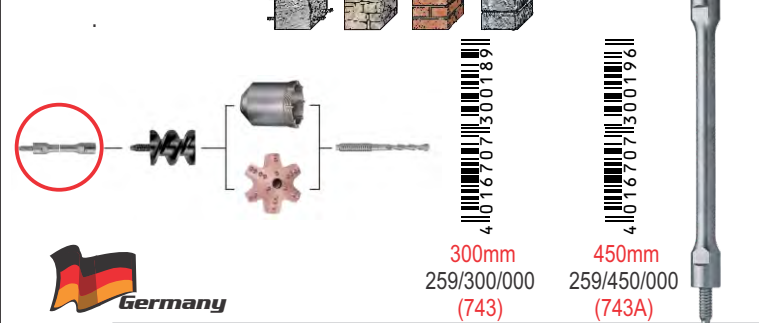

300mm 259/300/000 (743)	450mm 259/450/000 (743A)



KEIL Adapters with RATIO Thread Hammer 259

UNIT Κόπτης Σκυροδέματος, Χάλυβας Χρωμίου-Νικελίου-Μολυβδαινίου. Ταίριαζει απευθείας σε SDS-max. Ενισχυμένα με Καρφιά Καρβιδίου, με Προστασία Κραδασμών.

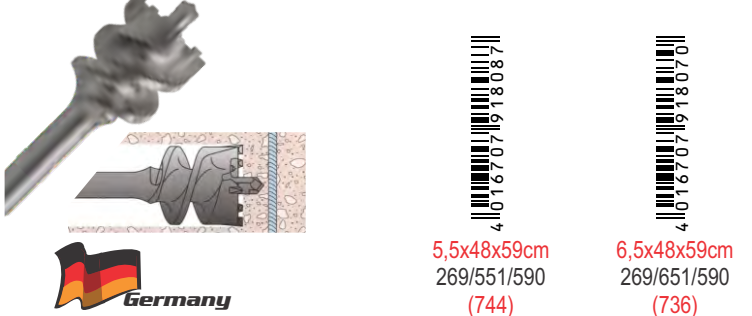

5,5x48x59cm 269/551/590 (744)	6,5x48x59cm 269/651/590 (736)



KEIL SDS-max Concrete Milling Cutter



UNIT Κεντρικό Τρυπάνι (αρίδα) για Ποτηροτρυπάνο Μπετού



KEIL Centre Drill Bit for Locating Shank M16 715/080/120 (728)

UNIT Εσωτερική Βάση Ποτηροτρυπάνου Μπετού

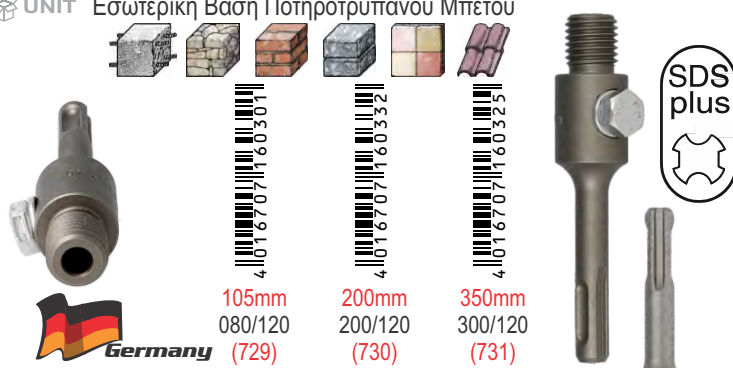

KEIL Locating Shank External Thread M16 SDS-plus 713

UNIT Ποτήρι για Ποτηροτρυπάνο Μπετού, με Κοπτικά Καρβιδίου, Κατασκευασμένο από χάλυβα χρωμίου-νικελίου-μολυβδαινίου με εξαιρετικά παχύ τοίχωμα

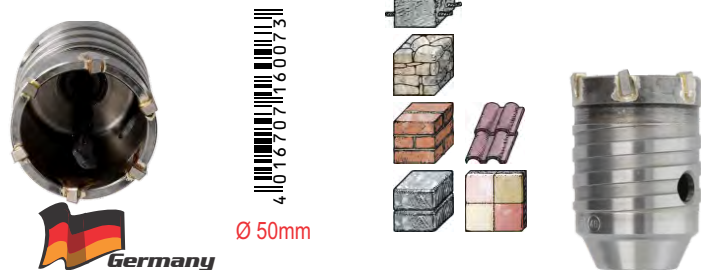

KEIL Hollow Core, M 16, 710/000/050 (511)

UNIT Ποτήρι για Ποτηροτρυπάνο Μπετού, με Κοπτικά Καρβιδίου, Κατασκευασμένο από χάλυβα χρωμίου-νικελίου-μολυβδαινίου με εξαιρετικά παχύ τοίχωμα

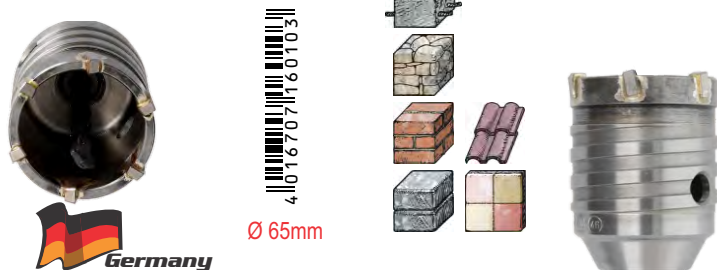

KEIL Hollow Core, M 16, 711/000/065 (510)

UNIT Ποτήρι για Ποτηροτρυπάνο Μπετού, με Κοπτικά Καρβιδίου, Κατασκευασμένο από χάλυβα χρωμίου-νικελίου-μολυβδαινίου με εξαιρετικά παχύ τοίχωμα

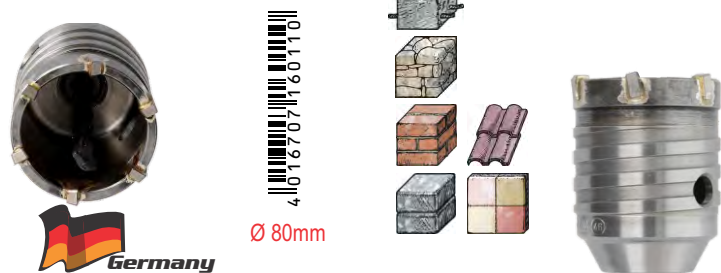

KEIL Hollow Core, M 16, 711/000/080 (337)

UNIT Ποτήρι για Ποτηροτρυπάνο Μπετού, με Κοπτικά Καρβιδίου, Κατασκευασμένο από χάλυβα χρωμίου-νικελίου-μολυβδαινίου με εξαιρετικά παχύ τοίχωμα

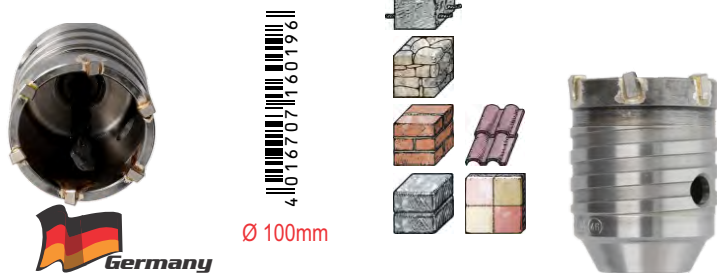

KEIL Hollow Core, M 16, 711/000/100 (336)

SET Ποτηροτρυπάνο Μπετού, με Κοπτικά Καρβιδίου, Κατασκευασμένο από χάλυβα χρωμίου-νικελίου-μολυβδαινίου με εξαιρετικά παχύ τοίχωμα

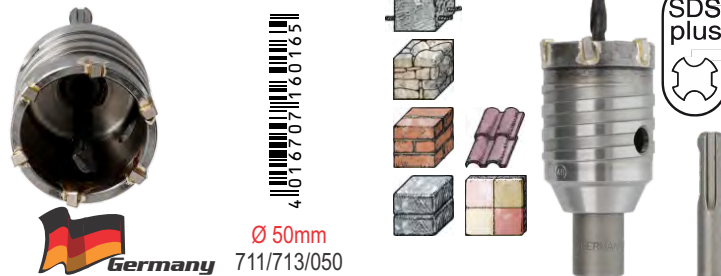

KEIL Hollow Core M16 Assembly, SDS-plus, Ø 50mm 711 (732)

SET Ποτηροτρυπάνο Μπετού, με Κοπτικά Καρβιδίου, Κατασκευασμένο από χάλυβα χρωμίου-νικελίου-μολυβδαινίου με εξαιρετικά παχύ τοίχωμα

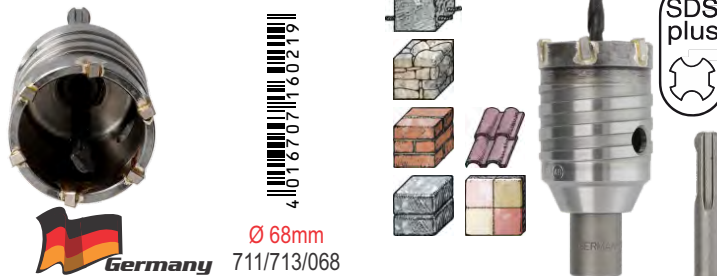

KEIL Hollow Core M16 Assembly, SDS-plus, Ø 68mm 711 (733)

SET Ποτηροτρυπάνο Μπετού, με Κοπτικά Καρβιδίου, Κατασκευασμένο από χάλυβα χρωμίου-νικελίου-μολυβδαινίου με εξαιρετικά παχύ τοίχωμα

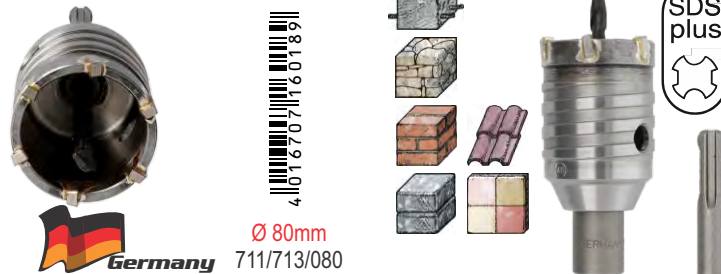

KEIL Hollow Core M16 Assembly, SDS-plus, Ø 80mm 711 (734)



UNIT Κεντρικό Τρυπάνι (αρίδα) για Ποτηροτρυπάνο Hole Saw Bi-Metal



KEIL Centre Drill Bit for Hole Saw 75mm, 320.100.080 (662)

SET Τρυπάνια (αρίδες) για Ποτήρι Μετάλλου, Ξύλου και Πλαστικού

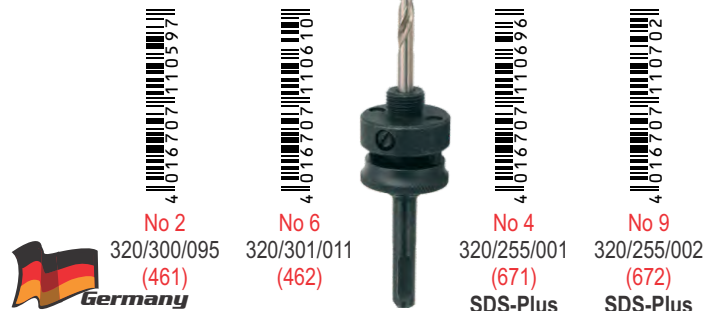

KEIL Locating Shank for Hole Saw Bi-Metal 320

UNIT Ποτήρια για Ποτηροτρυπάνο Μετάλλου, Ξύλου και Πλαστικού, Υψηλής Απόδοσης Χάλυβας

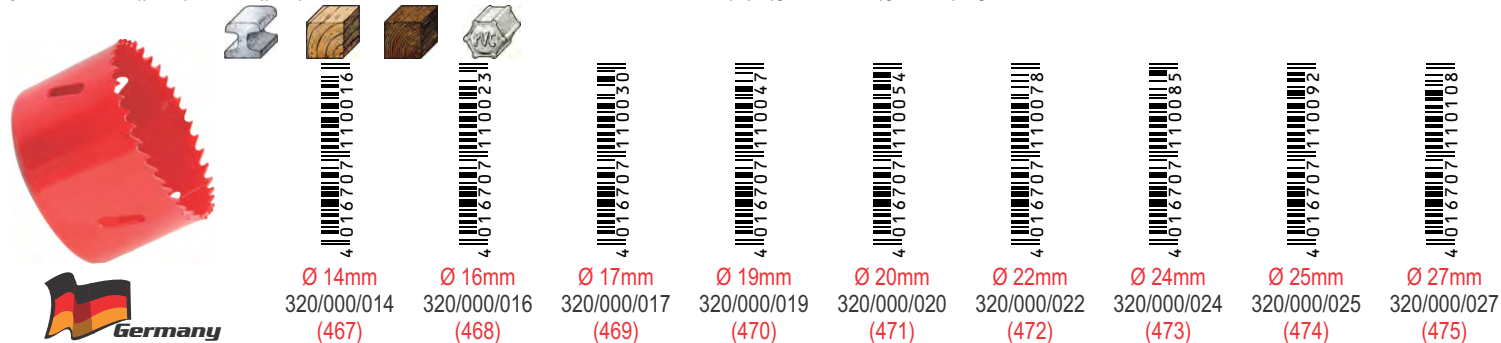

KEIL HSS Hole Saw Bi-Metal 320

Ποτήρια για Ποτηροτρυπάνο Μετάλλου, Ξύλου και Πλαστικού, Υψηλής Απόδοσης Χάλυβας

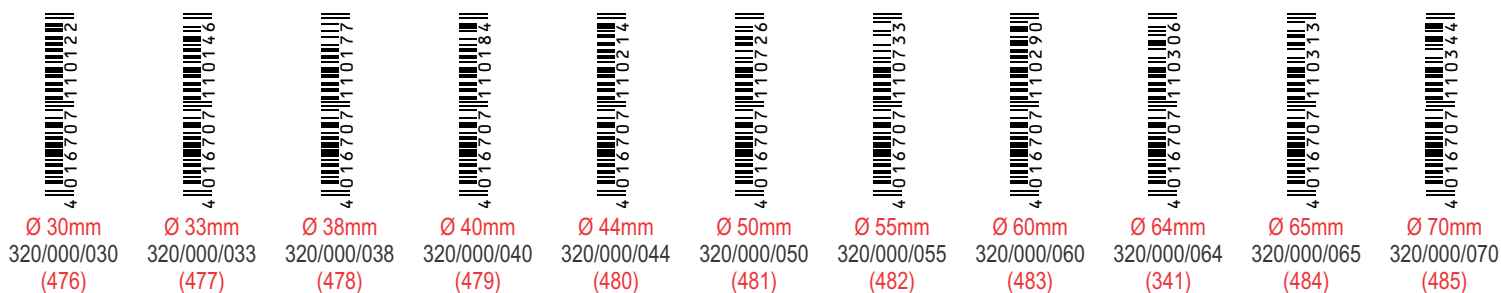

KEIL HSS Hole Saw Bi-Metal 320

Ποτήρια για Ποτηροτρυπάνο Μετάλλου, Ξύλου και Πλαστικού, Υψηλής Απόδοσης Χάλυβας

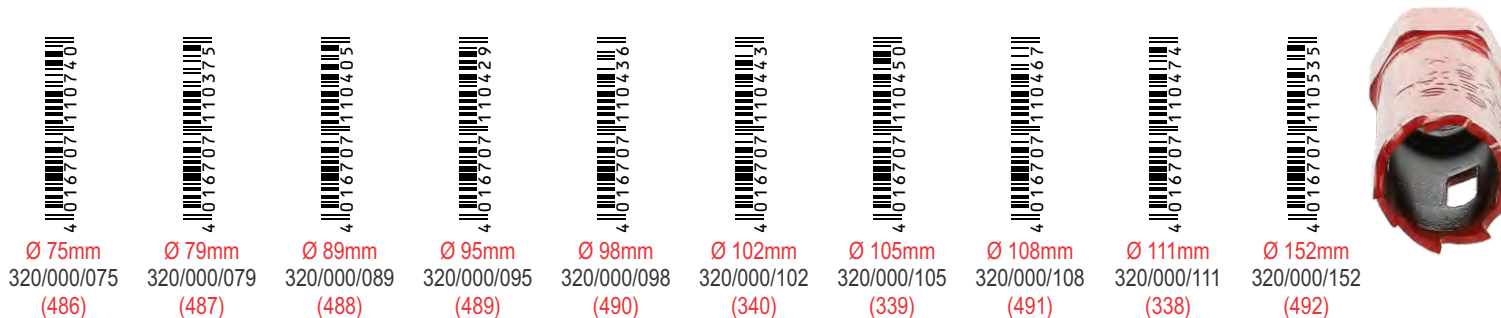

KEIL HSS Hole Saw Bi-Metal 320





SET Ποτηροτρυπάνο, 4 τεμ. Ø 35-68-83 mm



KEIL Hole Saw Bi-Metal Fitter's SET 4pcs, 320.251.383 (742)



UNIT Τρυπάνια (αρίδες) Παντός Υλικού, με Μύτη Καρβιδίου με Διαμάντι, Ειδική Γεωμετρία Αιχμής για Τέλεια Κοπή, ISO 5468









Ø 5mm	Ø 6mm	Ø 8mm	Ø 8mm	Ø 10mm	Ø 10mm	Ø 12mm	Ø 12mm	Ø 14mm
255/010 (635)	255/011 (634)	255/012 (633)	255/002 (632)	255/004 (631)	255/005 (630)	255/006 (629)	255/007 (628)	255/008 (627)

Germany

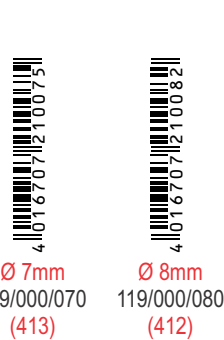
KEIL Universal Drill Bit SDS-Plus GOLDCRAFT 119/255

UNIT Τρυπάνια (αρίδες) Παντός Υλικού, με Μύτη Καρβιδίου με Διαμάντι, Ειδική Γεωμετρία Αιχμής για Τέλεια Κοπή, ISO 5468









Ø 3mm	Ø 4mm	Ø 5mm	Ø 5,5mm	Ø 6mm	Ø 6mm	Ø 6,5mm	Ø 7mm	Ø 8mm	
119/000/030 (420)	119/000/040 (419)	119/000/050 (418)	119/000/055 (417)	119/000/060 (416)	219/000/060 (415)	119/000/065 (414)	119/000/070 (413)	119/000/080 (412)	

Germany

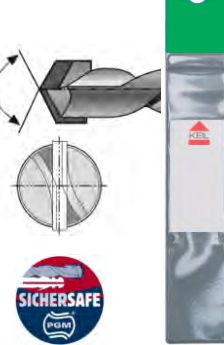
KEIL Universal Drill Bit GOLDCRAFT 119/000

Τρυπάνια (αρίδες) Παντός Υλικού, με Μύτη Καρβιδίου με Διαμάντι, Ειδική Γεωμετρία Αιχμής για Τέλεια Κοπή, ISO 5468

Ø 8mm	Ø 9mm	Ø 10mm	Ø 10mm	Ø 12mm	Ø 12mm	Ø 14mm	Ø 16mm
219/000/080 (411)	119/000/090 (410)	119/000/100 (409)	219/000/100 (408)	119/000/120 (407)	219/000/120 (406)	119/000/140 (405)	119/000/160 (404)

Germany

KEIL Universal Drill Bit GOLDCRAFT 119/000

UNIT Κεντρικό Τρυπάνι (αρίδα) για Ποτηροτρύπανο Παντός Υλικού, με Μύτη Καρβιδίου με Διαμάντι, Ειδική Γεωμετρία Αιχμής







Ø 8mm
719/080/120 (402)

Germany

KEIL Centre Drill Bit 8,0x70x120mm 719.080.120 (402)

SET Τρυπάνια (αρίδες) Παντός Υλικού, με Μύτη Καρβιδίου με Διαμάντι, Ειδική Γεωμετρία Αιχμής για Τέλεια Κοπή, ISO 5468





Ø 4, 5, 6, 8, 10mm



Germany

KEIL Universal Drill Bit GOLDCRAFT, 5 pcs, 119.350.410 (403)

UNIT Ποτηροτρύπανα Παντός Υλικού, με Μύτη Καρβιδίου με Διαμάντι, Ειδική Γεωμετρία Αιχμής για Τέλεια Κοπή, ISO 5468



Ø 50mm	Ø 60mm	Ø 65mm	Ø 68mm	Ø 80mm	Ø 105mm	Ø 33, 53, 67, 73mm
719/000/050 (494)	719/000/060 (739)	719/000/065 (495)	719/000/068 (497)	719/000/080 (496)	719/000/105 (738)	715/033/073 (498)









Germany

KEIL Universal Hole Saw M16 GOLDCRAFT 719



UNIT Τρυπάνια (αρίδες) Ξύλου, Κράμα Χάλυβα, Επεξεργασία Σκλήρυνσης, με Χαράκτες για Εύκολη Διάτρηση













							
Ø 3mm	Ø 4mm	Ø 5mm	Ø 6mm	Ø 7mm	Ø 8mm	Ø 9mm	Ø 10mm
180/000/030 (270)	180/000/040 (271)	180/000/050 (272)	180/000/060 (273)	180/000/070 (274)	180/000/080 (275)	180/000/090 (276)	180/000/100 (277)

 **Germany**

KEIL Wood Twist Drill Bit 180

Τρυπάνια (αρίδες) Ξύλου, Κράμα Χάλυβα, Επεξεργασία Σκλήρυνσης, με Χαράκτες για Εύκολη Διάτρηση

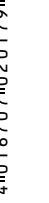

								
Ø 11mm	Ø 12mm	Ø 13mm	Ø 14mm	Ø 15mm	Ø 16mm	Ø 18mm	Ø 20mm	Ø 22mm
180/000/110 (278)	180/000/120 (279)	180/000/130 (280)	180/000/140 (281)	180/000/150 (282)	180/000/160 (283)	180/000/180 (284)	180/000/200 (285)	180/000/220 (286)

KEIL Wood Twist Drill Bit 180



UNIT Τρυπάνια (αρίδες) Ξύλου, Κράμα Χάλυβα, Επεξεργασία Σκλήρυνσης, με Χαράκτες για Εύκολη Διάτρηση







			
Ø 24mm	Ø 26mm	Ø 28mm	Ø 30mm
180/000/240 (287)	180/000/260 (288)	180/000/280 (289)	180/000/300 (290)



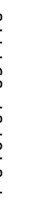

KEIL Wood Twist Drill Bit 180

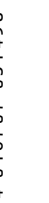
UNIT Τρυπάνια (αρίδες) Ξύλου, για Σπείρωμα, με Εξαγωνικό Στέλεχος, για Διάτρηση Ακριβείας Χωρίς Θραύσματα

								
Ø 6mm	Ø 8mm	Ø 10mm	Ø 10mm	Ø 12mm	Ø 12mm	Ø 14mm	Ø 16mm	Ø 18mm
181/060/250 (219)	181/080/250 (220)	181/100/250 (218)	181/100/450 (221)	181/120/250 (215)	181/120/450 (223)	181/140/450 (222)	181/160/250 (216)	181/180/250 (217)



KEIL Auger Bit Lewis Shape 181

SET Τρυπάνια (αρίδες) Ξύλου, Κράμα Χάλυβα, Επεξεργασία Σκλήρυνσης, με Χαράκτες για Εύκολη Διάτρηση. Ø4, 5, 6, 8, 10mm







 **Germany**

KEIL Wood Twist Drill Bit, 5 pcs 180/350/410 (695)

UNIT Τρυπάνια (αρίδες) Ξύλου, για Διάτρηση Ακριβείας



		
Ø 25mm	Ø 30mm	Ø 35mm
183/000/250 (681)	183/000/300 (682)	183/000/350 (683)



 **Germany**

KEIL Machine Forstner Drill Bit, Toothed 183/000



UNIT Τρυπάνια (αρίδες) Ξύλου, Ατσάλινες, με Προφίλ Άκρων Κοπής για Εύκολη Διάτρηση

Ø 6mm	Ø 8mm	Ø 10mm	Ø 12mm	Ø 13mm	Ø 14mm	Ø 16mm	Ø 18mm	Ø 20mm	
185/060/150 (107)	185/080/150 (90)	185/100/150 (91)	185/120/150 (92)	185/130/150 (93)	185/140/150 (94)	185/160/150 (95)	185/120/150 (96)	185/200/150 (97)	

KEIL Flat Bit KEILBIT 185

UNIT Τρυπάνια (αρίδες) Ξύλου, Ατσάλινες, με Προφίλ Άκρων Κοπής για Εύκολη Διάτρηση

Ø 22mm	Ø 24mm	Ø 25mm	Ø 28mm	Ø 30mm	Ø 32mm	Ø 35mm	Ø 38mm	Ø 40mm
185/220/160 (98)	185/240/160 (99)	185/250/160 (100)	185/280/160 (101)	185/300/160 (102)	185/320/160 (103)	185/350/160 (104)	185/380/160 (105)	185/400/160 (106)

KEIL Flat Bit KEILBIT 185

UNIT Τρυπάνια (αρίδες) Ξύλου, για Διαμηρές Διάτρηση, με Αυλάκια για Βέλτιστη Αφαίρεση Σκόνης, Μήκος 40cm

Ø 6mm	Ø 8mm	Ø 10mm	Ø 12mm	Ø 14mm	Ø 16mm	Ø 20mm	Ø 22mm	
350/060/400 (208)	350/080/400 (207)	350/100/400 (206)	350/120/400 (205)	350/140/400 (204)	350/160/400 (203)	350/200/400 (202)	350/220/400 (201)	

KEIL Drill Bit for Timbering, Round Shank 350

UNIT Προέκταση για Τρυπάνι (αρίδα) FLAT BIT, 30cm

4101670710251981

KEIL EXTENSION for FLAT BIT 185/hexagonal 185.000.001 (209)

SET Τρυπάνια (αρίδες) Ξύλου, 4 τεμ. Ø 10, 12, 16, 20 x 235 mm

4101670709225341

KEIL AUGER Drill Bits LEWIS with SDS-PLUS, 4pcs, 182.004.235 (727)

SET Μικρό Αναδιπλούμενο Πριόνι Κλαδέματος

4101670715301351

KEIL Foldable Pruning Saw 100/105/418 (735)

SET Μεγάλο Πριόνι Κλαδέματος, με Θήκη & Κλιπ Ζώνης

4101670715301421

KEIL Pruning Saw with Sheath & Belt Holder 100/105/424 (736)



UNIT Τρυπάνια (αρίδες) Γυαλιού, Καρβιδίου, Χρωμιωμένη, με Λεπτές Διασταυρούμενες Ακμές που Παρέχουν Ακριβή Διάτρηση.

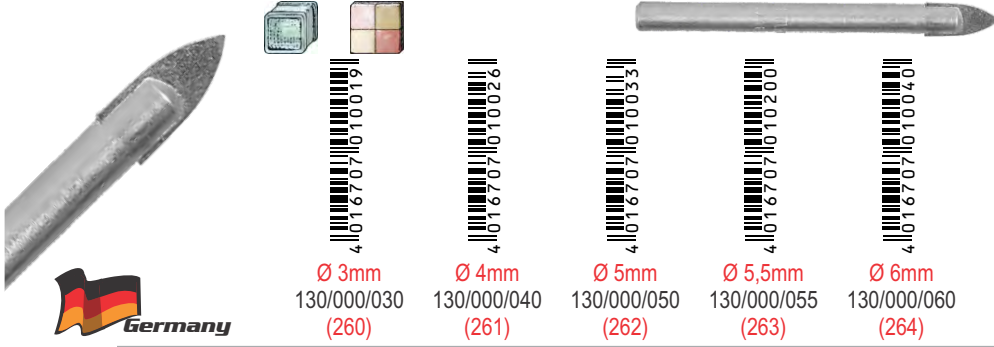

Ø 3mm 130/000/030 (260)	Ø 4mm 130/000/040 (261)	Ø 5mm 130/000/050 (262)	Ø 5,5mm 130/000/055 (263)	Ø 6mm 130/000/060 (264)
-------------------------------	-------------------------------	-------------------------------	---------------------------------	-------------------------------

KEIL Glass Drill Bit 130

UNIT Τρυπάνια (αρίδες) Γυαλιού, Καρβιδίου, Χρωμιωμένη, με Λεπτές Διασταυρούμενες Ακμές που Παρέχουν Ακριβή Διάτρηση.

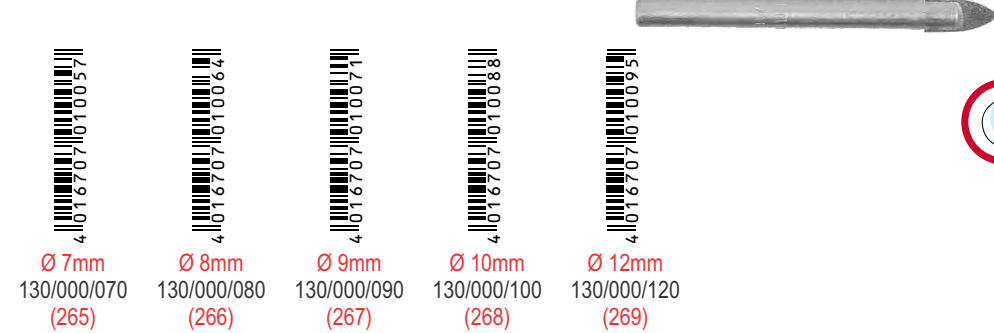

Ø 7mm 130/000/070 (265)	Ø 8mm 130/000/080 (266)	Ø 9mm 130/000/090 (267)	Ø 10mm 130/000/100 (268)	Ø 12mm 130/000/120 (269)
-------------------------------	-------------------------------	-------------------------------	--------------------------------	--------------------------------

KEIL Glass Drill Bit 130

UNIT Τρυπάνια (αρίδες) Γυαλιού, Καρβιδίου, Χρωμιωμένη, με Λεπτές Διασταυρούμενες Ακμές που Παρέχουν Ακριβή Διάτρηση.

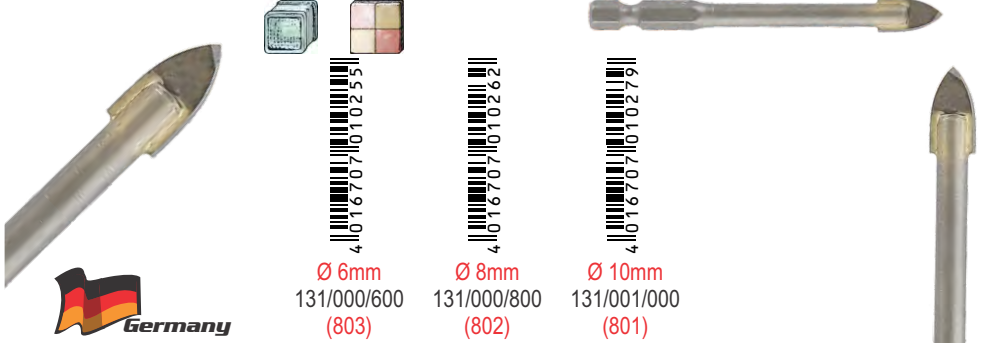

Ø 6mm 131/000/600 (803)	Ø 8mm 131/000/800 (802)	Ø 10mm 131/001/000 (801)
-------------------------------	-------------------------------	--------------------------------

KEIL Glass Drill KEILBIT 131

UNIT Τρυπάνια (αρίδες) Κεραμικών, με Διαμάντια Κολλημένα με Κενό, για Υλικά Σκληρότητας 9, ISO 5468

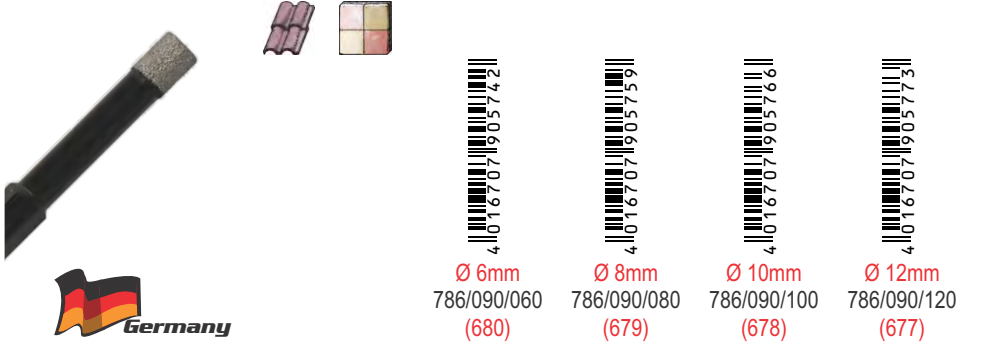

Ø 6mm 786/090/060 (680)	Ø 8mm 786/090/080 (679)	Ø 10mm 786/090/100 (678)	Ø 12mm 786/090/120 (677)
-------------------------------	-------------------------------	--------------------------------	--------------------------------

KEIL Tile Drill Bit KERAMIK Diamond For Dry Drilling 786

UNIT Τρυπάνια (αρίδες) Κεραμικών, με Διαμάντια Κολλημένα με Κενό, για Υλικά Σκληρότητας 9, ISO 5468

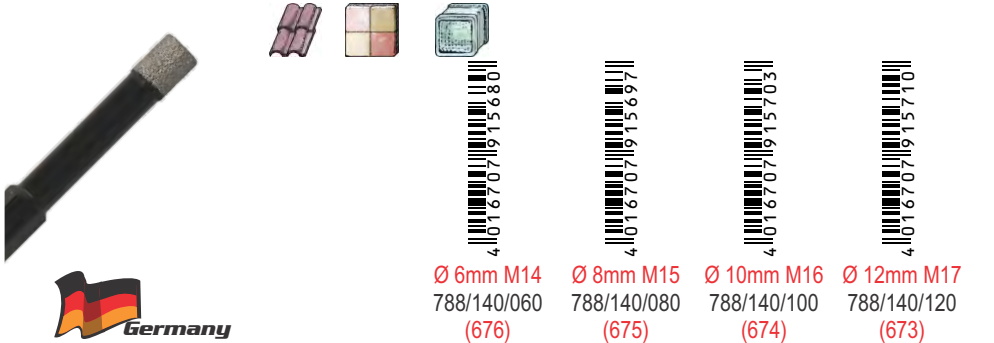

Ø 6mm M14 788/140/060 (676)	Ø 8mm M15 788/140/080 (675)	Ø 10mm M16 788/140/100 (674)	Ø 12mm M17 788/140/120 (673)
-----------------------------------	-----------------------------------	------------------------------------	------------------------------------

KEIL Tile Drill Bit KERAMIK Diamond For Dry Drilling 788



UNIT Τρυπάνια (αρίδες) Γενικής Χρήσης, Καρβίδιου, Ειδική Γεωμετρία Αιχμής για Τέλεια Κοπή, DIN 3126 - E 6.3

Germany

4 101670712200361	4 101670712200431	4 101670712200501
Ø 6mm	Ø 8mm	Ø 10mm
166/000/060 (806)	166/000/080 (805)	166/000/100 (804)

KEIL Universal Drill Bit KEILBIT 166

UNIT Τρυπάνια (αρίδες) Κεραμικών, Άκρη Καρβιδίου, Βολφραμίου, Τιτανίου TSM, με Στέλεχος ROTASTOP, για Υλικά Σκληρότητας 9, ISO 5461

Germany

4 101670715101061	4 101670715101131	4 101670715101201	4 101670715101371	4 101670715101441
Ø 4mm	Ø 5mm	Ø 6mm	Ø 8mm	Ø 10mm
151/018/040 (304)	151/018/050 (305)	151/018/060 (306)	151/018/080 (307)	151/018/100 (308)

ROTASTOP Die Kraft der Form

110°

KEIL Tile / Brick Drill Bit KERAMIK 151

SET Τρυπάνια (αρίδες) Κεραμικών 5 τεμ. Ø 4, 5, 6, 8, 10 mm

Άκρη Καρβιδίου, Βολφραμίου, Τιτανίου TSM, με Στέλεχος ROTASTOP, για Υλικά Σκληρότητας 9, ISO 5468

110°

ROTASTOP Die Kraft der Form

KEIL Tile / Brick Drill Bit KERAMIK 151.350.410 (697)

UNIT Τρυπάνια (αρίδες) Μπετού και Σκληρών Υλικών, Σφυρηλατημένος Χάλυβας, Ειδική Αιχμή Καρβιδίου με Διαμάντι, ISO 5468, 1000 rpm

Germany

4 101670719157721	4 101670719157891	4 101670719157961	4 101670719158021	4 101670719158571
Ø 4mm	Ø 5mm	Ø 6mm	Ø 8mm	Ø 10mm
168/000/040 (291)	168/000/050 (292)	168/000/060 (293)	168/000/080 (294)	168/000/100 (295)

120°

KEIL Drill Bit For Hard Stone HARDTEC 168

SET Τρυπάνια (αρίδες) Μπετού και Σκληρών Υλικών, Σφυρηλατημένος Χάλυβας, Ειδική Αιχμή Καρβιδίου με Διαμάντι, ISO 5468, 1000 rpm 4, 5, 6, 8, 10mm

Germany

4 101670719160451

KEIL Drill Bit For Hard Stone HARDTEC, 5 pcs 168.350.410 (694)

UNIT Οδηγός Τρυπήματος για Πλακάκια

Germany

KEIL Vacuum Guide Small (520)