

TOP RAIL PROFILES		MID RAIL PROFILES	
	GPT4100 Top profile for doors, 4100x56.5x27.2mm		GPM4100 Mid profile for drawers, 4100x73x26mm
			GPMIN90 Mid profile, internal corner joint 90°
			GPMEND End caps for drawer profile, pair, lh/rh
	GPCTS560SDL Curved top profile for 300x560mm curved base cabinet, left hand (can be cut down for 300x300mm applications)	WALL RAIL PROFILES	
	GPCTS560SDR Curved top profile for 300x560mm curved base cabinet, right hand (can be cut down for 300x300mm applications)		GPW3900 Profile for wall cabinets, 3900x19.6x20mm
			GPCWS300SD Wall curved profile for 300x300mm curved door
			GPCWSIC600 Wall curved profile for 600x600mm concave wall cabinet
	GPCTIC900 Curved top profile for 900x900mm concave corner base cabinet	VERTICAL PROFILES FOR LARDERS/APPLIANCES	
	GPTEX90 Top profile, external corner joint 90°		GPV4200MID Vertical profile (intermediate), 4200x71.6x41mm, trim to size
	GPTIN90 Top profile, internal corner joint 90°		GPV4200END Vertical profile (lateral), 4200x53.3x41mm trim to size
	GPTEND End caps for top profile, pair, lh/rh		GPAAPPFIL Appliance Filler 580x16x41, Set size
	GPTJOINT Mid Joint section for top profile	SECURING BRACKETS FOR TOP AND MID RAILS	
			GPFIXING Securing brackets for top and mid supports, black, pack 2 (sold in box quantities of 50)

BASE UNIT

Aluminium Top rail profile

- The top rail profile for base unit doors/drawers is available in straight lengths of 4.1m (GPT4100) and in set curved sections (see page 6).
- Single straight rail lengths are cut down to size (using a circular chop saw) to fit the requested number of cabinets.
- Securing brackets to fit rail profiles to the cabinets must be ordered separately (GPFIXING).
- A range of accessories are available for the top rail profile including end caps (GPTEND), mid joint (GPTJOINT) an internal 90° corner (GPTIN90) and an external 90° corner (GPTEX90).



TOP RAIL PROFILE CABINET DETAILS



Overall cabinet dimensions

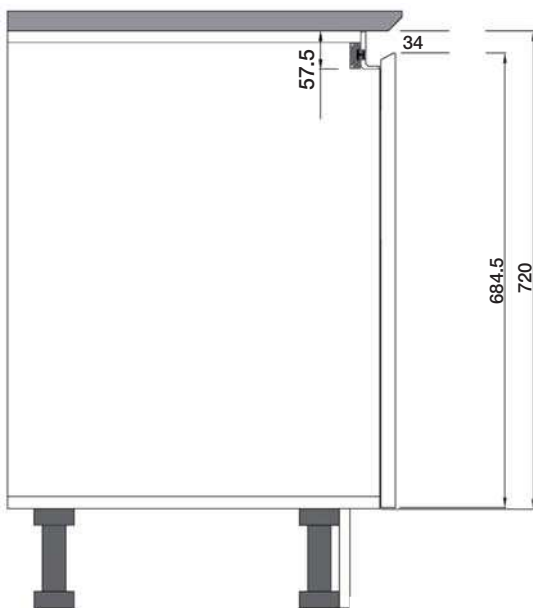

Routing cabinet detail

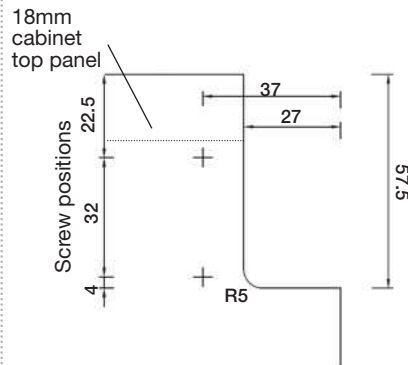

Rail profile

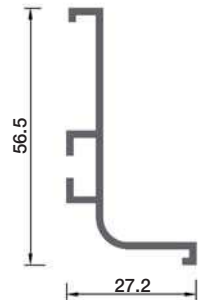

Fitted rail detail

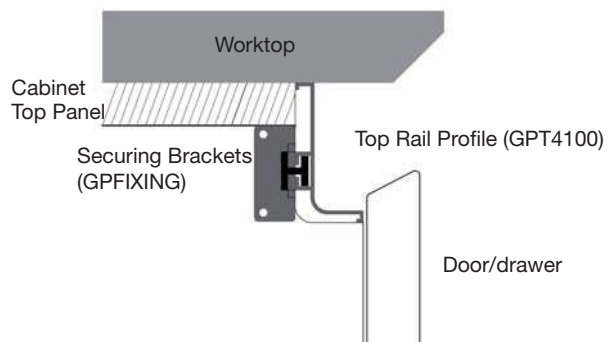

SEE PAGE 5 FOR DETAILS ON FITTING RAIL PROFILES TO CABINETS WITH SECURING BRACKETS (GPFIXING).

BASE UNIT

Mid rail profile

- The mid rail profile for base unit drawers is available in straight lengths of 4.1m (GPM4100) and in a curved section for the concave drawer pack in 1200x1200mm cabinets (GPCMSCAVE).
- Single straight rail lengths are cut down to size (using a circular chop saw) to fit the requested number of cabinets.
- Securing brackets to fit rail profiles to the cabinets must be ordered separately (GPFIXING).
- An internal corner joint (GPMIN90) and end cap (GPMEND) are available separately



MID RAIL PROFILE AND CABINET DETAILS

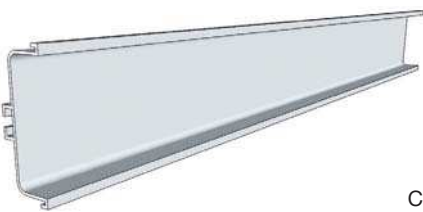

Fitted rail detail

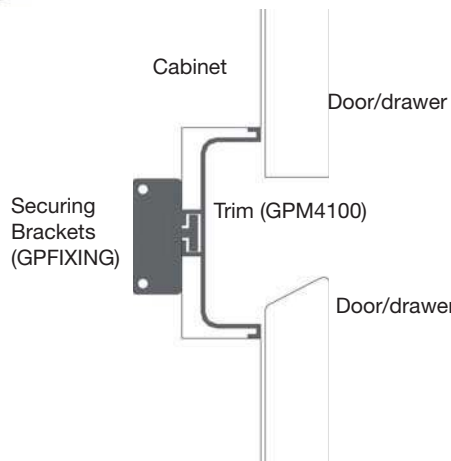

Routing cabinet detail

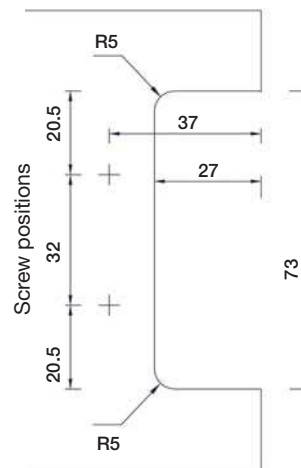

Rail profile

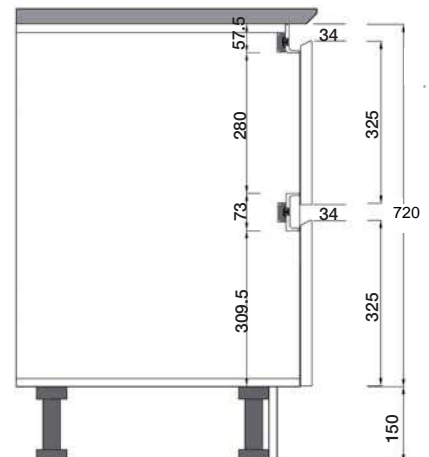
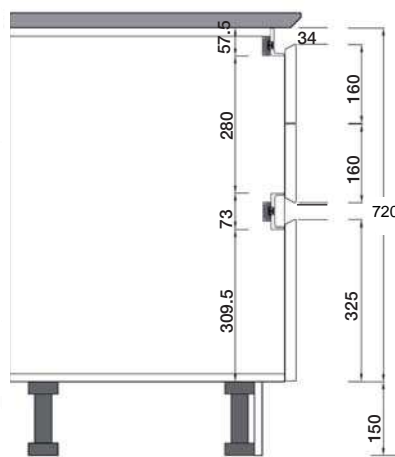
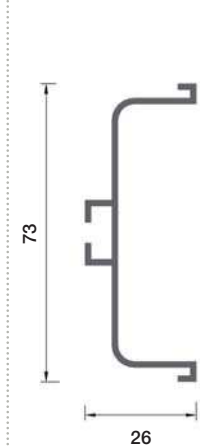

BASE UNIT

Integrating under counter appliances

- The top rail profile (GPT4100) can be used when planning a dishwasher into base cabinets.
- XXL dishwasher models can not be used with rail profiles. It is recommended to use a dishwasher with a height range adjustment between 815 - 875mm for the appliance to sit under the rail.

NOTE: We recommend setting the plinth at 155mm for extra clearance



INTERGRATED DISHWASHER DETAILS

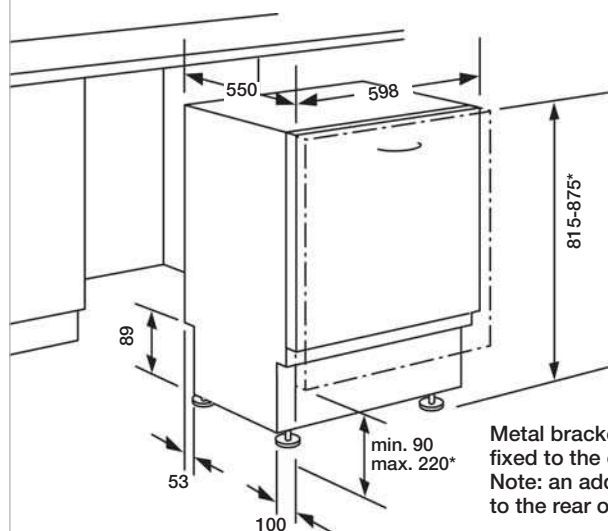

Metal brackets (supplied with dishwasher) should be fixed to the outer face of adjacent cabinets. Please Note: an additional bracing baton may be required to the rear of the machine to help reduce movement.

If a draw pack is situated beside an interated appliance, we recommend using the (GPMEND) end caps to stop any gaps.

Fitted rail detail

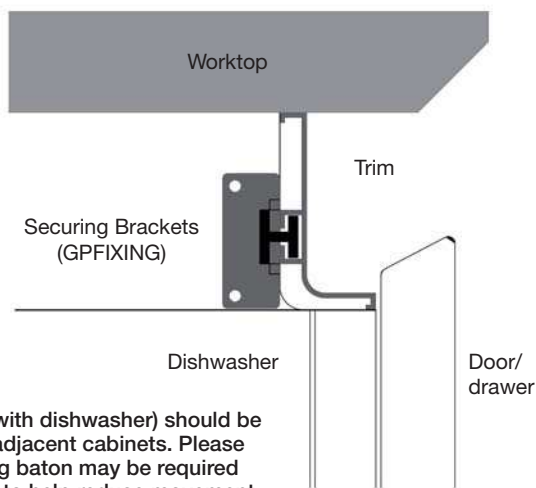

UNDERMOUNTED OVEN APPLICATIONS

A top rail profile can not be used in conjunction with an under-mounted oven. Rails must stop on each side of the appliance. They can be finished with GPTEND & GPMEND end caps.

If using a freestanding appliance, end panels will need to be fitted either side of the appliance and the rail profile terminated against the panel.

Illustration shows an example of handleless rail profiles (with end caps) terminating against an oven.



BASE UNIT

Securing brackets for top and mid rail profiles

- Securing brackets (GPFIXING) are required to fit both top and mid rail profiles to cabinets and must be ordered separately to the rail profiles.

NEW & IMPROVED

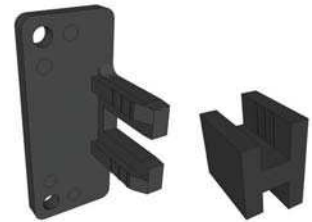

GPFIXING

FITTING TOP RAIL PROFILES

Routing cabinet detail for top profile

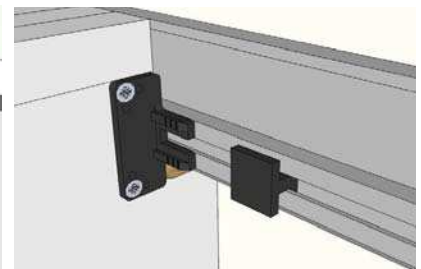
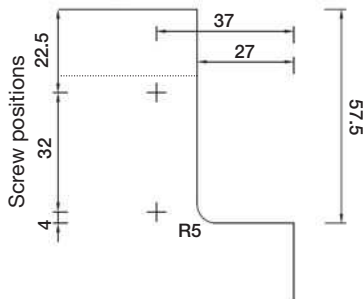

1. Router cabinet gable ends for top rail profile and mark screw positions.

2. Screw securing brackets into place.

3. Slide 'H' connector into runner on back of rail trim, sit rail on routed gable ends and slide connector to clip into the securing bracket and hold rail in place.

FITTING MID RAIL PROFILES

Routing cabinet detail for mid profile

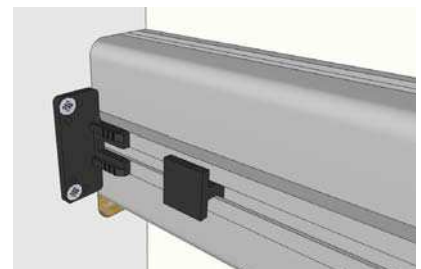
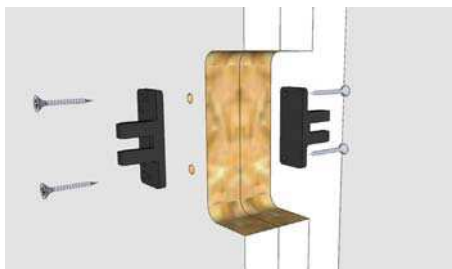
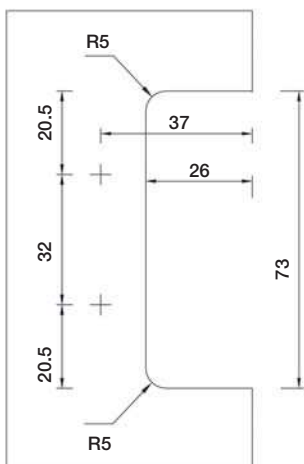

1. Router cabinet gable ends for mid rail profile and mark screw positions

2. Screw securing brackets into place

3. Slide 'H' connector into runner on back of rail trim, sit rail on routed gable ends and slide connector to clip into the securing bracket and hold rail in place.

BASE UNIT

Top profile internal corner joint 90° (for use with GPT4100)

When applying a corner post or internal corner doors, a top internal corner joint is required for two top profiles to run into. The internal corner joint section is supplied with two screws which when in position secure the joint to the rail profiles.



GPINT90

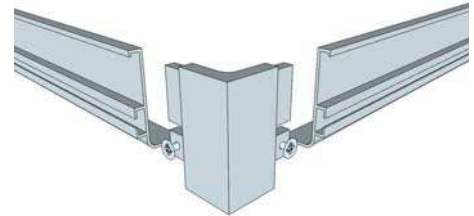
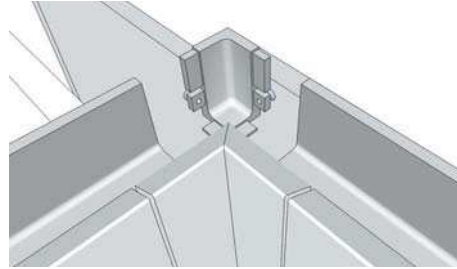

End caps top profile, pair, LH/RH (for use with GPT4100)

End caps can be used when top rail trims come to an end (e.g. against a wall, end panel next to appliances). A grub screw is supplied to attach the end cap firmly to the rail.

PLEASE NOTE:
When using end caps, a 2mm spacing must be taken in to account (when cutting down the trim).



GPTEND
(L/R pair)

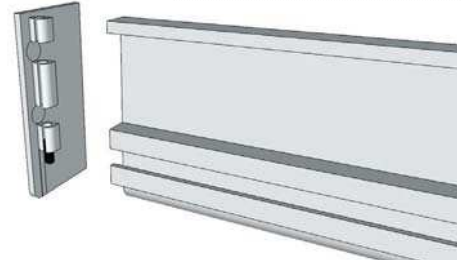
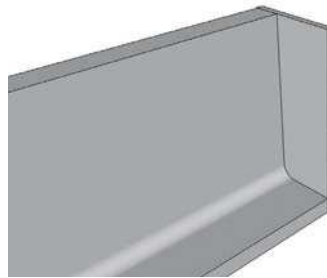

Mid joint section for top profile (for use with GPT4100)

A mid joint section is available to hide joints in certain applications where two top rail profiles meet (e.g. when a straight rail profile meets a curved rail section or when you need to join the length).



GPTJOINT

Front view

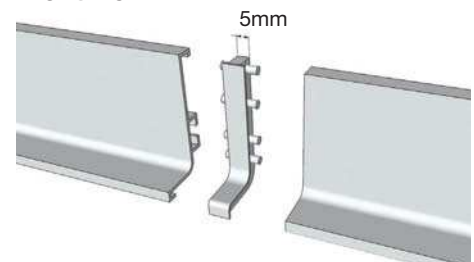

Rear view

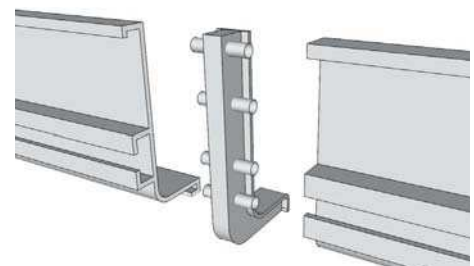

PLEASE NOTE:
When using mid joints, a 5mm spacing must be taken into account when cutting down the rail profiles that are being joined at either side.

BASE UNIT

Top profile external corner joint 90° (for use with GPT4100)

An external corner joint is available when running top rail profiles around an island or corner. The external corner joint is supplied with two screws, which when in position, secure the joint firmly to the rail profile.



GPTEX90

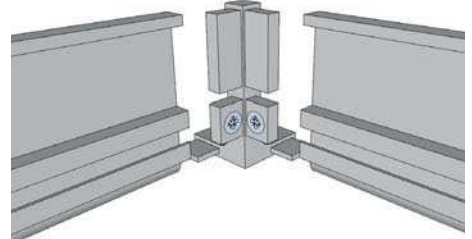
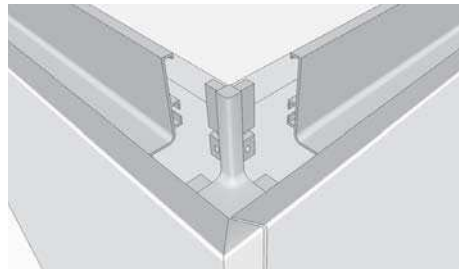

Mid profile internal corner joint 90° (for use with GPM4100)

When joining two mid rail profiles in a corner application a mid profile internal corner joint is required for two mid profiles to run in to. The internal corner joint is supplied with two screws which when in position secure the joint to the rail profiles.



GPMIN90



End caps for mid drawer profile, pair, LH/RH (for use with GPM4100)

End caps can be used when mid rail trims come to an end (e.g. against a wall next to an end panel or next to appliances). A grub screw is supplied to attach the end cap firmly to the rail.

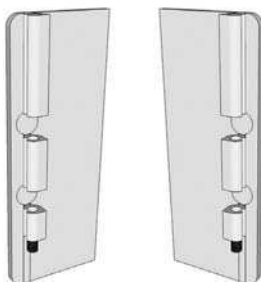

GPMEND

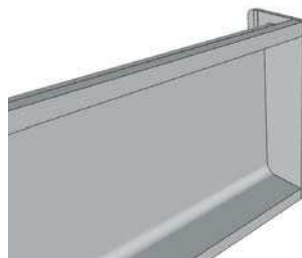

PLEASE NOTE: When using end caps, a 2mm spacing must be taken in to account.

WALL CABINETS

Profiles for wall cabinets

- Rail profiles for wall units are available in straight lengths of 3.9m (GPW3900) as well as curved rail sections.
- Single straight rail lengths are cut down to size (using a circular chop saw) to fit between gables.

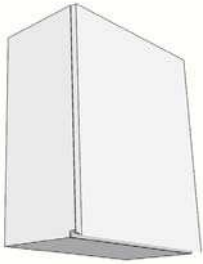

GPW3900



GPCWSIC600



GPCWS300SD

Routing cabinet detail

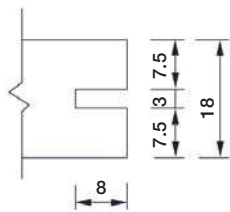

Wall rail profile

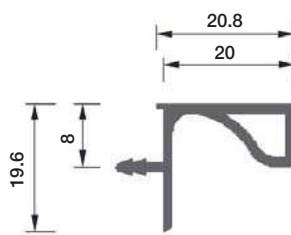

Fitted rail detail

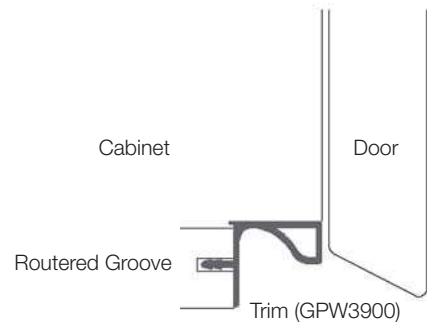

FITTING WALL RAIL PROFILES

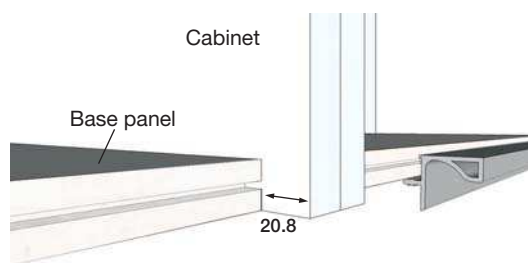

The base panel of the wall unit needs to be set back 20.8mm to accommodate the rail profile within the overall depth of the cabinet.

A groove (3.2mm high, 8mm deep) must then be routed into the base panel using a slotting cutter.

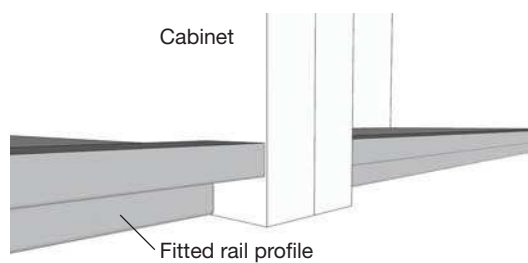

The rail profile then slots into the routed groove (clear silicone adhesive should be used to bind the rail with the panel).

APPLIANCE/LARDER UNIT

Vertical profile (intermediate)

- The vertical intermediate profile (GPV4200MID) should be used in the scenario where two opening doors meet. Due to the width and placement of the trims, a 35mm spacer is required at the back between the two cabinets to maintain the space created by the trim.
- The front of the gables on the cabinets need to be set back by 20mm for the trim to overlap behind the doors.
- The trim is securely fixed to the cabinets with 4 x 30mm countersunk screws.

NOTE: This product replaces GPV2250MID. The new specification includes a wider trim profile to allow easier opening of slab doors. Rail profiles are now supplied in lengths of 4.2m and now require a void of 35mm between adjacent cabinets.

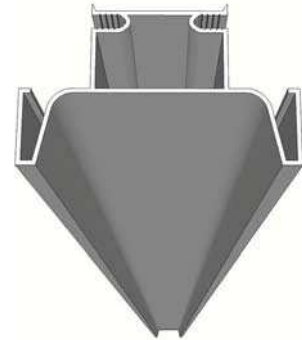

GPV4200MID

Vertical profile (intermediate),
4200x71.6x41mm, trim to size

Rail application between two opening doors

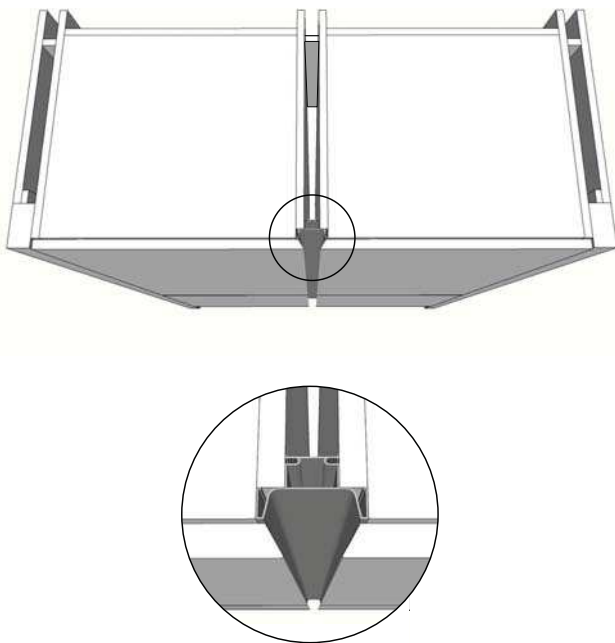

When joining cabinets in larder runs, a spacer is needed at the back to maintain the 35mm void created by the trim profile. The spacer is screw fixed to the cabinets from the inside of each cabinet.

Fitting detail

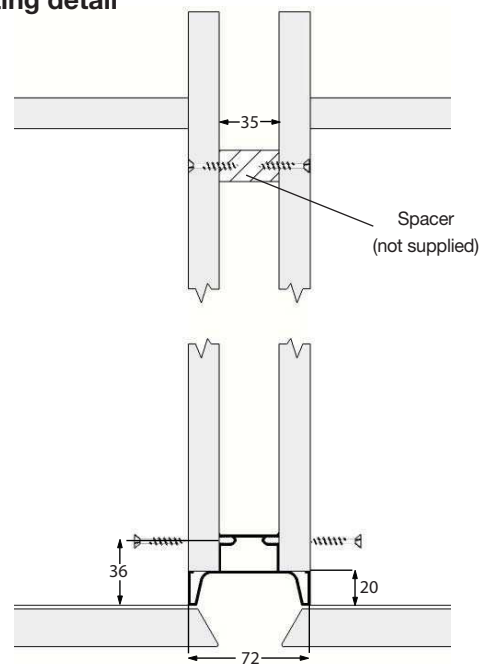

NOTE: Try to position the screw holes in the cabinet so they are concealed (such as behind hinge plates) when internal components are added. When planning appliance housings don't forget to allow 35mm between units where access to a handle is required.

TOMBA DOOR

Vertical profile (lateral)

- The vertical lateral profile (GPV4200END) should be used in the scenario where you have an opening door to one side and don't require access to a handle on the opposite side. It can also be used to end a run where an end panel or accessory is fitted.
- Due to the width and placement of the trims, a 35mm spacer is required at the back between the two cabinets and 66mm between cabinet and end panel/feature post based on 50mm post and 18mm panel.
- The front of the gable on the cabinet needs to be set back by 20mm for the trim to overlap behind the door.
- The trim is securely fixed to the cabinets with 4 x 60mm countersunk screws.

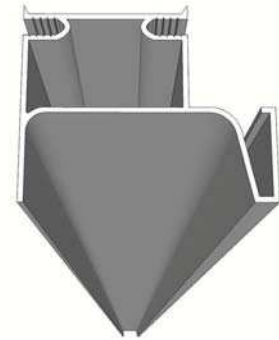

GPV4200END
Vertical profile (lateral),
4200x53.3x41mm, trim to size

Rail application between opening door and end panel/post or hinge side of adjacent door

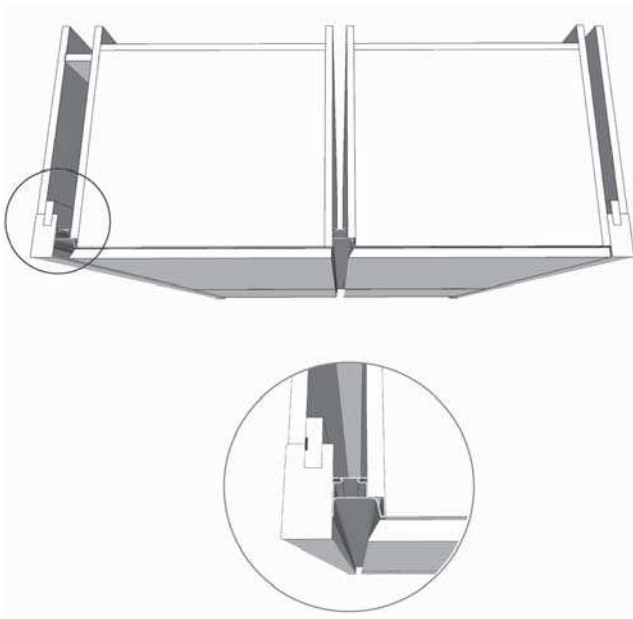

When joining cabinets in larger runs, a spacer is needed at the back to maintain the 35mm void created by the trim profile. The spacer is screw fixed to the cabinets from the inside of each cabinet.

Fitting detail

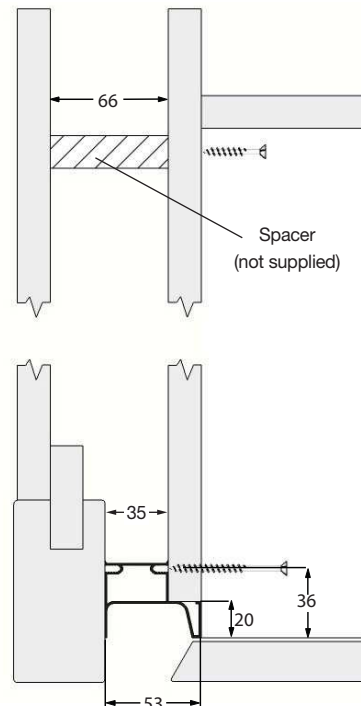

NOTE: Try to position the screw holes in the cabinet so they are concealed (such as behind hinge plates) when internal components are added.

NOTE: This product replaces GPV2250END. The new specification includes a wider trim profile to allow easier opening of slab doors. Rail profiles are now supplied in lengths of 4.2m and now require a void of 35mm between adjacent cabinets.

PLUG/FILLER FOR APPLIANCE FITTINGS ON VERTICAL RAILS

Appliance Filler

- The GPAAPPFIL is used to conceal the void behind an appliance when used in an appliance housing using vertical rail profiles
- Screw fixed into the cabinet gable
- 3No. pre-drilled, countersunk holes for ease of fitting
- Designed to fit seamlessly inside both Vertical Profiles GPV4200MID and GPV4200END
- Should the appliance require a screw fixing into the cabinet, the appliance filler can be drilled to accommodate the screws
- The trim can be cut down to suit different sized appliances and applications. When doing so, we recommend that the cut edge is treated with metal file to remove any sharp edges and is positioned out of the sight.



GPAAPPFIL
Appliance Filler
580x16x41, Set size

Appliance Plug shown set down from the top of the appliance by 10mm. When stacking appliances, we recommend leaving a 10mm gap to the top and bottom of both appliances.

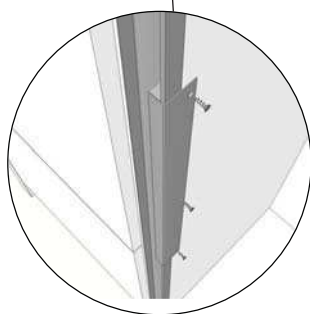

Screw-fix into cabinet gable using 3No. 4x12mm screws before installation of the appliance.

Fitting detail

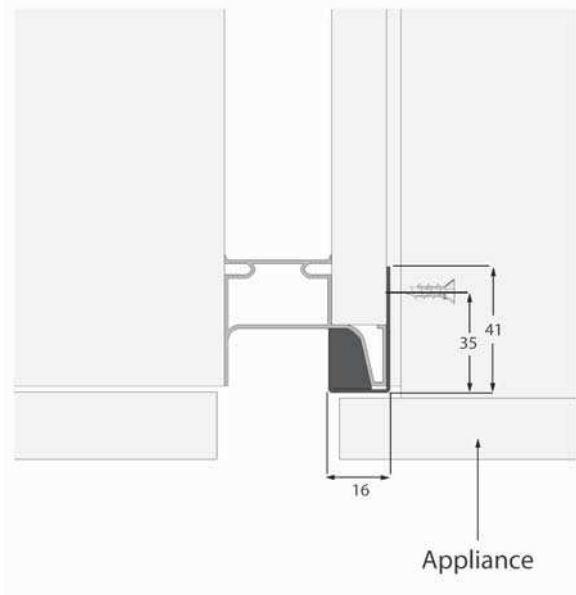

Designed to match both vertical profiles for a seamless look and screw-fixed into the cabinet.

NOTE: It is possible to drill through the trim if the appliance requires a screw-fixing into the cabinet.