

the Air Fryer Chef™ Plus

Instruction Book - Suits all LAF600 models



Breville®



Contents

- 2 Breville recommends safety first
- 7 Components
- 8 Control panel & LCD display
- 9 Functions
- 16 Hints & Tips
- 17 Care & Cleaning
- 18 Troubleshooting

BREVILLE RECOMMENDS SAFETY FIRST

At Breville we are very safety conscious. We design and manufacture consumer products with the safety of you, our valued customer, foremost in mind. In addition, we ask that you exercise a degree of care when using any electrical appliance and adhere to the following precautions.

IMPORTANT SAFEGUARDS

READ ALL INSTRUCTIONS BEFORE USE AND SAVE FOR FUTURE REFERENCE

- Remove and safely discard any packaging material and promotional labels before using the air fryer for the first time.
- To eliminate a choking hazard for young children, remove and safely discard the protective cover fitted to the power plug of this air fryer (where applicable).
- Do not place the air fryer near the edge of a bench or table during operation. Ensure the surface is level, clean and free of water and other substances.
- Do not operate the air fryer on a sink drain board.
- Do not place the air fryer on or near a hot gas or electric burner, or where it could touch a heated oven.
- Do not operate the air fryer on an inclined surface. Do not move the air fryer while it is switched on.
- Do not cover the air inlet and the air outlet openings while the air fryer is operating.

- Do not fill the pan with oil or any other liquid as the air fryer works using hot air.
- Never use the pan without the basket inside.
- Never touch the inside of the air fryer while it is operating.
- Position the air fryer at a minimum distance of 50cm away from walls, curtains, cloths and other heat sensitive materials when in use.
- Always operate the air fryer on a stable and heat resistant surface. Do not use on a cloth covered surface, near curtains or other flammable materials.
- Always put the ingredients to be cooked in the basket and prevent the ingredients from coming into contact with the heating elements.
- Never overfill the basket.
- Do not place cardboard, plastic, paper or other flammable materials into the air fryer.
- Do not cover any external part of the air fryer with metal foil. This will cause overheating of the air fryer.
- Do not touch the pan or basket for some time after use as it will be very hot. Only hold the pan by the handle.
- Always use extreme caution when removing the pan or disposing of hot grease or other hot liquids that may have accumulated in the pan during cooking.
- Do not press the basket release button while shaking. Always place the pan on a heat-resistant flat surface or the silicone mat provided. Hold the pan by the handle and press the basket release button to remove the basket from the pan.
- Do not turn the basket upside down with the pan still attached to it as any excess oil that has collected on the bottom of the pan will leak onto the ingredients.
- Be careful of hot steam and air when removing the pan from the air fryer. The pan and the ingredients are hot after operation. Depending on the type of ingredients in the air fryer, steam may escape from the pan.
- Extreme caution must be used when the air fryer contains hot food and liquids. Do not move the air fryer during cooking.

- Always ensure that the basket and the pan are thoroughly dried after cleaning and are reinserted into position before operating the air fryer.
- When using the air fryer, provide sufficient clearance (minimum 50cm) above and on all sides for air circulation.
- This air fryer is not intended to be operated by means of an external timer or separate remote-control system.
- Hot steam is released through the air outlet openings on the rear side of the air fryer during operation. Always keep your hands and face at a safe distance from the steam and air outlet openings.
- The temperature of accessible surfaces may be hot when the air fryer is operating and for some time after use.
- If dark smoke emits from the air fryer during operation, immediately turn the air fryer off by pressing the Start/Cancel button once and switch off at the power outlet. Wait for the smoke emission to stop and for the air fryer to cool down before removing the pan from the air fryer.
- Do not touch hot surfaces; use insulated oven mitts.
- Always wear protective, insulated oven mitts when inserting, removing or handling items from the air fryer.
- Allow the air fryer to cool before handling.
- Do not place hands inside the air fryer during operation.
- Do not insert over-sized foods into the air fryer as they create risk of fire or electric shock.
- Do not use metal kitchen utensils or abrasive cleaning materials to clean the pan and the basket as this may damage the non-stick coating on the pan and the basket.
- Do not clean the interior of the air fryer with metal scouring pads as pieces can break off the pad and touch electrical parts, creating risk of electric shock.
- Do not attempt to operate the air fryer by any other method than those described in this book.
- Always ensure the air fryer is properly assembled before use. Follow the instructions provided in this book.
- Do not place anything on top of the air fryer when in use and when stored.

- The air fryer should not be left unattended at any time when in use.
- Always ensure the air fryer has cooled, been turned off, switched off at the power outlet, and the cord has been unplugged from the power outlet before attempting to move, disassemble, clean, or store the air fryer.
- Do not place the air fryer in direct sunlight. Colour fading and discolouration may occur when the air fryer is consistently exposed to UV light.
- Keep the air fryer clean. Follow the cleaning instructions provided in this book.
- Do not, under any circumstances, modify the power plug or use a power plug adapter.
- Do not place this appliance on or near a heat source, such as hot plate, oven or heaters.
- Position the appliance at a minimum distance of 20cm away from walls, curtains and other heat or steam sensitive materials and provide adequate space above and on all sides for air circulation.
- Do not let the power cord hang over the edge of a bench or table, touch hot surfaces or become knotted.
- This appliance is for household use only. Do not use this appliance for anything other than its intended use. Do not use in moving vehicles or boats. Do not use outdoors.

IMPORTANT SAFEGUARDS FOR ALL ELECTRICAL APPLIANCES

- Fully unwind the power cord before use.
- Connect only to a 230V or 240V power outlet.
- The appliance must be used on a properly grounded outlet. If unsure, please consult a qualified electrician.
- **Misuse may cause injury.**
- The appliance is not intended for use by persons (including children) with reduced physical, sensory or mental capabilities, or lack of experience and knowledge, unless they have been given supervision or instruction concerning use of the appliance by a person responsible for their safety.

- Children should be supervised to ensure that they do not play with the appliance.
- Always switch the appliance off at the power outlet and unplug at the power outlet when the appliance is not in use.
- Before cleaning, always switch the appliance off at the power outlet, unplug at the power outlet and remove the power cord, if detachable, from the appliance and allow all parts to cool.
- To protect against electric shock, do not immerse the power cord, power plug or appliance in water or any other liquid or allow moisture to come in contact with the parts, unless it is recommended in the cleaning instructions.
- Any maintenance other than cleaning should be performed at an authorised Breville Service Centre.
- It is recommended to regularly inspect the appliance. To avoid a hazard, do not use the appliance if power cord, power plug or appliance becomes damaged in any way. Return the entire appliance to the nearest authorised Breville Service Centre for examination and/or repair.
- The installation of a residual current device (safety switch) is recommended to provide additional safety protection when using electrical appliances. It is advisable that a safety switch with a rated residual operating current not exceeding 30mA be installed in the electrical circuit supplying the appliance. See a qualified electrician for professional advice.
- During electrical storms, the appliance should be disconnected from the power source at the wall socket to prevent any electrical surges that may arise during the storm and which may inadvertently cause damage to the appliance and its electronic componentry.



This symbol indicates, temperature of accessible surfaces may be high when the appliance is operating and for some time after use.

**FOR HOUSEHOLD USE ONLY
SAVE THESE INSTRUCTIONS**

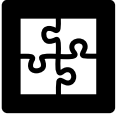

Components

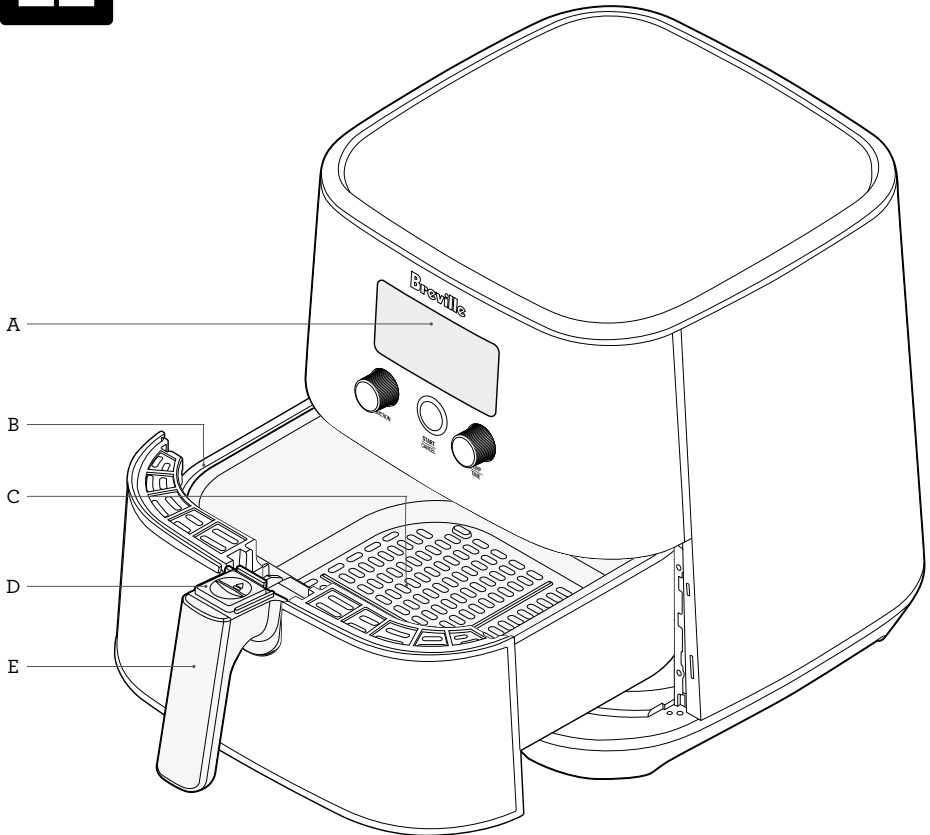

- A. Control panel & LCD display
- B. Air frying pan (holds the basket)
- C. 4.8L large basket capacity to cook up to 2.2kg
- D. Basket release button with safety cover
- E. Basket handle
- F. Heat-resistant silicone mat.

Image not to scale, actual mat size:
175mm diameter.

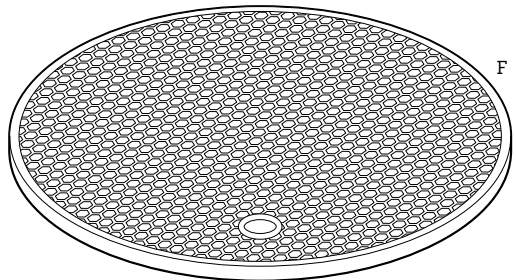

Not shown

- Air outlet opening at rear
- Cord wrap at rear

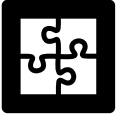

Control Panel & LCD Display

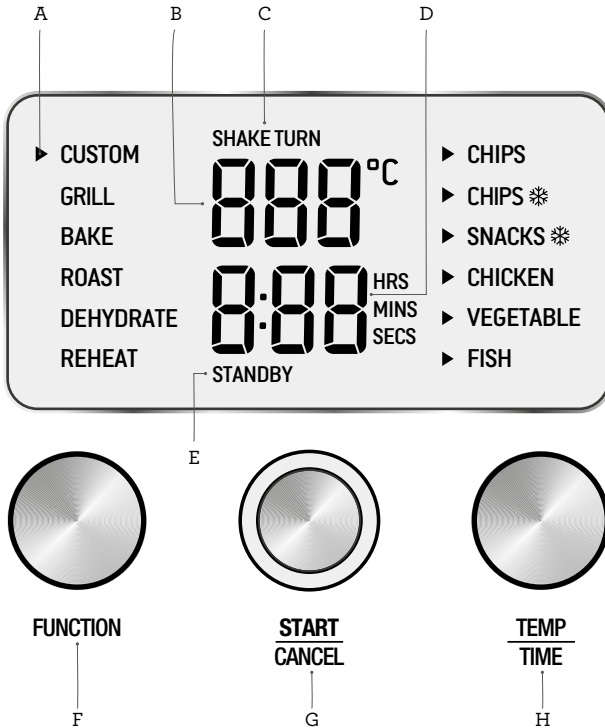

- A. Function Indicator
- B. Cooking Temperature (°C)
- C. Shake / Turn Alert
- D. Cooking Time (HRS/MINS/SECS)
- E. Standby Mode Indicator
- F. Function Dial
- G. Start/Cancel Button with Light Ring
- H. Temp/Time Dial



Functions

BEFORE FIRST USE

Remove all packaging materials and any promotional labels from your air fryer. Thoroughly clean the basket and pan with warm soapy water and a non-abrasive, soft scouring pad, rinse and dry thoroughly. Wipe the outside of the air fryer with a damp cloth.



NOTE

When turned on for the first time, the air fryer may emit vapours for up to 20 minutes. This is due to the protective substances on the heating element. It is safe, not detrimental to the performance of the air fryer and will dissipate with use.



WARNING

Hot steam is released through the air outlet openings on the rear side of the air fryer during operation. Always keep your hands and face at a safe distance from the steam and air outlet openings. Place the air fryer on a dry, flat, level surface. Ensure the air fryer is not too close to the edge of the bench top.

OPERATING YOUR BREVILLE AIR FRYER CHEF™ PLUS

1. Place the basket into the pan and lock into place, then slide the basket release safety cover over the basket release button. (See Fig. 1).

Fig. 1

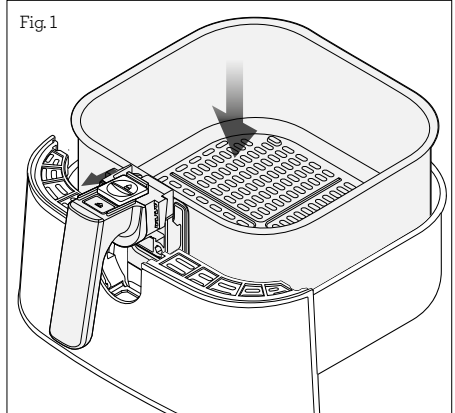

2. Place food in the basket and slide the pan into the air fryer until you hear a "click" sound. (See Fig. 2).

Fig. 2

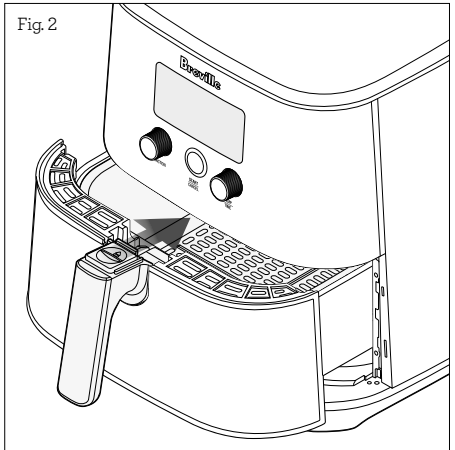

3. Plug the power cord into a 230/240 volt power outlet. Ensure cord is fully extended. Switch on at power outlet and the air fryer will beep twice; START/CANCEL light ring will flash twice and the LCD screen will illuminate white.
4. The function menu will appear with the function indicator displayed on the CUSTOM setting.



5. Turn the FUNCTION dial to scroll through the preset menu options.
6. The top digits on the LCD screen indicate the preset cooking temperature for the selected setting. The temperature digits on the LCD screen will begin to flash. Turn the TEMP/TIME dial to the left to reduce the temperature or to the right to increase the temperature or keep at the default temp, then push the TEMP/TIME dial to confirm the selection.

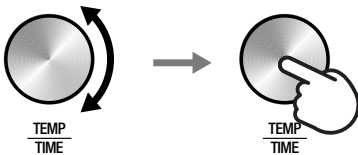
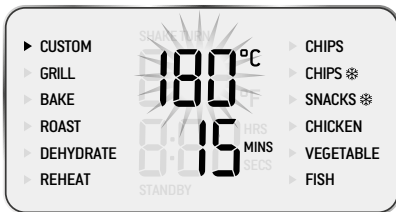

7. The bottom digits indicate the preset cooking time for the selected setting. The time digits on the LCD screen will begin to flash. Turn the TEMP/TIME dial to the left to reduce the cooking time or to the right to increase the cooking time.

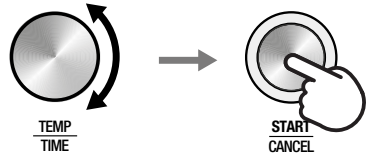
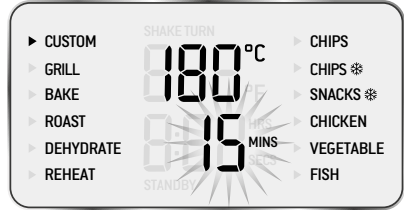

8. Press the START/CANCEL button to confirm setting. The button backlight will illuminate red and the LCD screen will illuminate orange.
9. The displayed timer will begin to count down.
10. The cooking temperature and time can be adjusted at any time during the cooking cycle by pressing and turning the TEMP/TIME dial.
11. During the cooking process, pressing the START/CANCEL button will cancel the cooking cycle, the LCD screen will return to the home screen and the button backlight will turn off.

COOKING FUNCTION	PRESET TIME	TIME RANGE	PRESET TEMP (°C)	TEMP RANGE (°C)	SHAKE/TURN FOOD ALERT: Unit to beep twice at the following timings during the preset & user set cooking cycle
Custom	15 mins	1min-60min Press and hold start/cancel button for 3 seconds to set & save new default time	180	90-200 Press and hold start/cancel button for 3 seconds to set & save new default temp	First beeping reminder at 10 mins, then every 10 mins until preset or user set cook time elapses SHAKE to display on LCD screen
Grill	5 mins	1min-30min	200	100-200	N/A
Bake	30 mins	1min-60min	150	100-200	N/A
Roast	60 mins	1min-60min	180	100-200	First beeping reminder at 30 mins, then every 20 mins until preset or user set cook time elapses TURN to display on LCD screen
Dehydrate	3 hrs	1min-12hrs	70	40-90	First beeping reminder at 30 mins, then every 30 mins until preset or user set cook time elapses SHAKE to display on LCD screen
Reheat	10 mins	1min-2hrs	165	60-180	N/A
Fresh Chips	25 mins	1min-60min	200	100-200	First beeping reminder at 10 mins, then every 5 mins until preset or user set cook time elapses SHAKE to display on LCD screen
Frozen Chips	20 mins	1min-60min	190	100-200	First beeping reminder at 10 mins, then every 5 mins until preset or user set cook time elapses SHAKE to display on LCD screen
Frozen Snacks	12 mins	1min-60min	190	100-200	First beeping reminder at 5 mins, then every 5 mins until preset or user set cook time elapses SHAKE to display on LCD screen
Chicken	18 mins	1min-60min	190	100-200	First beeping reminder at 10 mins, then every 10 mins until preset or user set cook time elapses TURN to display on LCD screen
Vegetables	25 mins	1min-60min	190	100-200	First beeping reminder at 10 mins, then every 5 mins until preset or user set cook time elapses TURN to display on LCD screen
Fish	10 mins	1min-60min	190	100-200	N/A

TIME RANGE

- Time is adjustable by 1-minute increments for each setting up to 1 hour
- Time is adjustable by 5-minute increments for each setting from 1 hour to 2 hours
- Time is adjustable by 10-minute increments for the dehydrate function

TEMP RANGE is adjustable by 5-degree increments for each setting



IMPORTANT NOTE

For the SHAKE/TURN FOOD ALERT - The unit will continue cooking during and after beeping reminder UNLESS the basket is removed to shake/turn the food (recommended), at which point the unit will pause the cooking cycle until the basket is returned to the unit and cooking will resume automatically.

SHAKE/TURN FOOD REMINDER

Some foods may require shaking or turning throughout the cooking cycle to ensure even results. As a helpful reminder, the air fryer will sound 2 beeps periodically and SHAKE/TURN will flash on the LCD screen for 1 minute during the cooking cycle. The air fryer will continue cooking during and after shake/turn beeping reminder. When the basket is removed, the air fryer will pause cooking and the time and temperature will flash on the screen. Once the basket is returned to the air fryer, the cooking will resume automatically.



CAUTION

The silicone mat included with this appliance is not a baking mat and should never be used inside the air fryer.

Always place the pan on a heat-resistant flat surface or the silicone mat provided with this unit. Hold the pan by the handle and slide the safety cover forward, then press the basket release button to remove the basket from the pan. When you take the pan out of the air fryer, be cautious of the hot steam and air. Depending on the type of food in the air fryer, steam may escape from the pan. Do not touch the pan after use as it is very hot. Only hold the pan by the handle. Returning the pan back to the air fryer will resume cooking automatically.



NOTE

To shake or turn the food in the basket, it is recommended to remove the basket from the pan.



TIP

Heavier food items may not have enough room to shift effectively by shaking. It may be helpful to also turn the food with a heat resistant utensil at least once during the cooking process for more even results.



NOTE

Use insulated oven mitts when touching hot surfaces.

12. When the cooking time has elapsed, the air fryer will beep 5 times to indicate the cooking cycle has finished. The fan will continue to run for 30 seconds after the cooking has ended to cool down the air fryer.

The air fryer will return to standby mode if not used for 10 minutes. In standby mode, the LCD screen will not illuminate and "STANDBY" will display on the screen, however all function options will still be visible. To re-activate the air fryer out of standby mode, press the START/CANCEL button, or turn any dial. The LCD screen will illuminate and STANDBY will disappear off the screen.

13. Remove the pan from the air fryer and place on a heat-resistant surface or the silicone mat provided. Slide the safety cover forward and press the basket safety release button. Lift the basket out of the pan before removing contents, unless contents are more than 1.5kg in weight. (See Fig. 3).



WARNING

When removing cooked food items with a weight greater than 1.5 kg, securely hold the pan by the handle and pull the pan out of the air fryer, placing the pan on a heat-resistant flat surface. Do not slide the basket release cover forward. Do not press the basket safety release button. Do not lift the basket out of the pan. Both the pan and basket must remain intact. Remove heavy food items from the basket using appropriate kitchen utensils.

Fig. 3

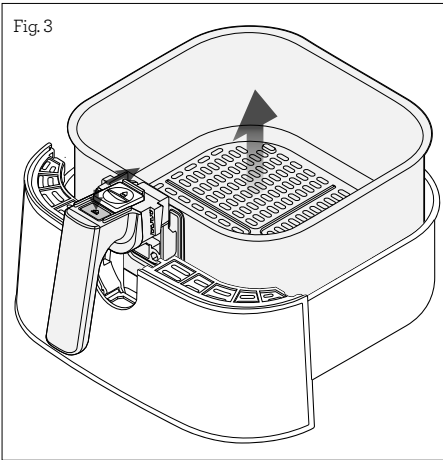

NOTE

If food is not entirely cooked, slide the pan back into the air fryer and repeat from step 4.

14. Remove food from the basket and empty the pan of excess cooking residue once it has cooled.



CAUTION

Always place the pan on a heat-resistant flat surface or on the silicone mat provided. Hold the pan by the handle and press the basket release button to remove the basket from the pan. Be careful of hot steam and air when you remove the pan from the air fryer. The pan and food are hot after operation, and depending on the type of food in the air fryer, steam may escape from the pan. Do not touch the pan after use as it is very hot. Only hold the pan by the handle.



NOTE

- Excess residue such as fats, oils, and juices from cooking will collect at the bottom of the pan, under the basket. Do not turn the basket upside down with the pan still attached as any excess oil that has collected will leak onto the food.
- An 18-20cm round baking tin (not included) can be used for baking cakes, quiche, reheating food and more. Leave adequate space on either side of the baking tin when you place it in the basket to ensure the airflow can pass around it.



WARNING

Never place baking tins or other ovenproof dishes or moulds directly in the pan. Always place the baking dish in the air frying basket. Always wear oven mitts when you handle the baking tin or other oven-proof dishes or moulds.

COOKING TABLE

The following table provides basic cooking guidelines for popular, convenience and frozen foods. Please note that due to the variations in thickness, size and the moisture content of the foods being cooked, temperature and time should be adjusted to suit. Always ensure that the food is thoroughly cooked to food-safe temperature before consuming.

FOOD	QUANTITY APPROX.	COOKING TIME APPROX.	TEMP (°C)	NOTES
GRILL				
Chicken Breast	100g-1kg	15-20mins	200	
BAKE				
Round Cake	18-20cm round cake tin	50-60mins	130	
½ cake batter	18-20cm	30mins	150	
Muffins	6 muffins	15-30mins	150	
Quiche	20cm round tin	30-60mins	150	
ROAST				
Whole Chicken**	1kg-1.5kg	1 hour	180	
Beef	500g-2kg	20mins - 1 hour	180	
DEHYDRATE***				
Fresh Fruits***	100g-500g	2-4 hours	70	Remove any blemishes, seeds, pips and stone and slice
Fresh Vegetable***	100g-500g	2-5 hours	70	Peeled, thinly sliced
Fresh Meat***	100g-500g	2-6 hours	75	
POTATOES & CHIPS				
Fresh Chips*	200g-1kg	15-25mins	200	
Frozen Chips*	200g-1kg	15-20mins	190	
FROZEN SNACKS				
Spring Rolls*	100g-500g	12 mins	190	
Sausage Rolls*	12 pieces	12-15mins	190	
Chicken Nuggets*	400g-800g	12 mins	160	
CHICKEN				
Chicken Wings/ Drumsticks	100g-800g	15-30mins	190	
VEGETABLES				
Root Vegetables	100g-800g	15-25mins		Cut into 3-5cm pieces
FISH				
Fish (fillet)	100g-600g	8-15mins	180	
Prawns (fresh)	500g-1kg	10-30mins	180	

See next page for footnotes for this Cooking Table.

Footnotes for the Cooking Table

- * Cooking results may vary depending on the brand of food used.
- ** If the cooking time takes more than 60 minutes, increase the timer to the remaining cooking time required before cooking time elapses.
- *** When dehydrating, produce drying times can vary. Drying times are affected by the quantity, thickness of the sliced produce and the moisture content of the food itself. (Therefore, broad drying times have been given in the table above).

Do not dry lighter foods like kale, parsley, herbs as the force of the fan may blow them into the fan and heating element, which could become a hazard.



CAUTION

- Never overfill the basket with ingredients. Ensure that the food inserted into the basket fits well, allowing good heat flow.
- Always wear protective, insulated oven mitts when inserting, removing or handling items from the air fryer.

REHEAT FUNCTION

The reheat function is designed for reheating pre-cooked foods. To use the REHEAT function, turn the FUNCTION dial to scroll through the preset menu options until you have reached REHEAT. Adjust the temperature and time as required. Press START/CANCEL button to start reheating.

	PRESET TIME	TIME RANGE	PRESET TEMP (°C)	TEMP RANGE (°C)
REHEAT	10mins	1min- 2hrs	165	60-180

When the reheat time has elapsed the air fryer will beep 5 times to indicate cooking cycle finished. The fan will continue to run for 30 seconds after reheating has ended to cool the air fryer.

CUSTOM FUNCTION

One of your favourite cooking settings can be saved using the CUSTOM option. Turn the FUNCTION dial on the preset menu choices until you reach CUSTOM. Adjust the time and temperature to your liking, then press and hold the START/CANCEL button for 3 seconds. The air fryer will automatically save your preferred cooking settings and sound a lengthy beep. To update and save a new custom temperature and time, repeat the above steps. Only one custom temperature and time setting may be saved at any given time.



Hints & Tips

- When the air fryer basket is open during cooking, push the START/CANCEL button once to stop the cooking process. Following that, the air fryer then enters the cooking menu and, after 10 minutes of inactivity, goes into standby mode.
- Shaking or turning ingredients at least once during cooking optimises the result and can help prevent uneven cooking.
- For a crispier result, coat fresh potatoes in oil before placing them in the basket.
- The baking tin (which is not provided) should not be filled more than 3/4 full if the baking materials contain rising agents.
- Avoid cooking high fat content foods like bacon in the air fryer as they may spit grease over the heating element and fan.
- Most snacks that can be cooked in an oven can also be cooked in an air fryer.
- Using a heat-resistant utensil such as tongs to stir food instead of shaking may be easier for some food types.
- The air fryer basket may fit baking tins up to a maximum size of either a round 20 cm in diameter or a rectangle 12 cm by 17 cm (baking tin not included).
- For baking, small baking tins that fit the air frying oven basket can be purchased from most homeware stores.

DIMENSIONS:

Square: 7.5cmx7.5cm

Heart: 10cmx10cm

Bundt: 11cm diameter



Care & Cleaning

Clean the air fryer after every use.



NOTE

Do not use metal kitchen utensils or abrasive cleaning materials to clean the pan and basket as this may damage the non-stick coating on the pan and basket.

1. Before cleaning, ensure the air fryer is turned OFF and switched off at the power outlet then unplugged from the power outlet. Allow the air fryer to cool completely.
2. Remove the pan to allow the air fryer to cool faster. Soak the pan and basket in hot soapy water for approximately 10 minutes before cleaning so it is easier to wash. Clean the pan and basket with hot soapy water and a non-abrasive, soft scouring pad or sponge.
3. Do not place any part of the air fryer in the dishwasher.
4. Wipe the inside and outside of the air fryer with a soft damp cloth.
5. Dry thoroughly before use.



NOTE

Exposure to cooking oils and cleaning chemicals may cause colour fading and discolouration to the air fryer. If the air fryer is exposed to oils or chemicals, turn off and unplug the appliance and use a damp cloth to clean the surface of the air fryer.

STORAGE

1. When storing the air fryer, switch off and then remove the power supply plug from the power outlet and then wrap the cord around the cord wrap handle at the rear of the unit. Ensure the appliance is completely cool, clean and dry.
2. Place the basket into the pan and lock into place. Slide the pan back into the air fryer until you hear a "click" sound.
3. Do not place heavy objects on top.



CAUTION

To prevent damage to the appliance, do not use alkaline cleaning agents when cleaning, use a soft cloth and a mild detergent



Troubleshooting

POSSIBLE PROBLEM	POSSIBLE REASON	SOLUTION
The air fryer does not work	<ul style="list-style-type: none">• The air fryer is not plugged in.• The timer is not set.• The pan and basket have not been placed correctly into the air fryer.	<ul style="list-style-type: none">• Insert the plug into a 230V or 240V power outlet and turn the power on.• Set the timer using the increase decrease timer buttons.• Completely slide the pan with basket locked in place back into the air fryer.
Food is not cooking properly	<ul style="list-style-type: none">• There is too much food in the basket.• The set temperature is too low.• The cooking time is too short.	<ul style="list-style-type: none">• Put less food in the basket. Smaller batches will cook more evenly.• Increase the temperature using the temperature control buttons.• Increase the cooking time by using the timer control buttons.
Food is not evenly cooked	<ul style="list-style-type: none">• Some foods need to be shaken or turned halfway through the cooking.	<ul style="list-style-type: none">• For pre-packaged food, follow instructions for cooking found on packaging.
I cannot slide the pan into the air fryer properly.	<ul style="list-style-type: none">• There is too much food in the basket.• The basket is not placed in the pan correctly.	<ul style="list-style-type: none">• Do not overfill the basket.• Push the basket down into the pan until you hear a click.
White smoke comes out of the air fryer.	<ul style="list-style-type: none">• Greasy or high fat food being cooked in air fryer.• The pan still contains grease residues from previous use.	<ul style="list-style-type: none">• When greasy food is cooked in the air fryer a large amount of oil will leak into the pan. The oil produces white smoke and the pan may heat up more than usual. Lower the temperature of the air fryer to reduce the smoke.• White smoke is caused by grease heating up in the pan. Make sure you clean the pan properly after each use.
Homemade chips are fried unevenly.	<ul style="list-style-type: none">• Potato sticks were not soaked properly before cooking.• Suboptimal potato type was used.	<ul style="list-style-type: none">• Soak the potato sticks in a bowl for at least 30 minutes, take them out and dry them with paper towel.• Floury-type potatoes are best, such as Russet and Sebago.
Homemade chips are not crispy when they come out of the air frying oven.	<ul style="list-style-type: none">• The crispiness of the chips depends on the amount of oil and water in the chips	<ul style="list-style-type: none">• Make sure you dry the potato sticks properly before you add the oil.• Cut the potato sticks smaller for a crispier result.• Add slightly more oil for a crispier result.

POSSIBLE PROBLEM	POSSIBLE REASON	SOLUTION
Packaged chips are not coming out crisp and brown.	<ul style="list-style-type: none"> • Packaged chips will give varying results depending on the brand and type of potato used. Some packaged chips do not brown well when oven cooking or even fried in oil. 	<ul style="list-style-type: none"> • Try another brand. • Cook for longer period.
E1 appears on the screen	<ul style="list-style-type: none"> • NTC open circuit. 	<ul style="list-style-type: none"> • Error message code can reset by turning off the unit at the power outlet. • If the error message code persist display on the screen, please contact the Breville Customer Service Centre.
E2 appears on the screen	<ul style="list-style-type: none"> • NTC short circuit 	<ul style="list-style-type: none"> • Error message code can reset by turning off the unit at the power outlet. • If the error message code continues to display on the screen, please contact the Breville Customer Service Centre.
E3 appears on the screen	<ul style="list-style-type: none"> • Overheat protection 	<ul style="list-style-type: none"> • Turn off unit until it cools down. If the error message code continues to display on the screen, please contact the Breville Customer Service Centre

Breville Customer Service Centre

Australian Customers

Phone: 1300 139 798

Web: www.breville.com

New Zealand Customers

Phone: 0800 273 845

Web: www.breville.com

Breville®

Breville, the Breville Logo and Air Fryer Chef are trademarks of Breville Pty Ltd ("Breville") and Breville's products are distributed in Australia and New Zealand under license.

Copyright Breville Pty. Ltd. 2023. All other brand names may be trademarks of their respective owners.

Due to continued product improvement, the products illustrated/photographed in this booklet may vary slightly from the actual product.