

DAVIS & WADDELL

essentials

2 in 1 Electric Steamboat Hotpot and Grill
F5100251

Thank you for choosing the Davis & Waddell 2 in 1 Electric Steamboat Hotpot and Grill. To ensure proper operation and to maintain the lifespan of your appliance, please read these instructions carefully before use.

Product Overview

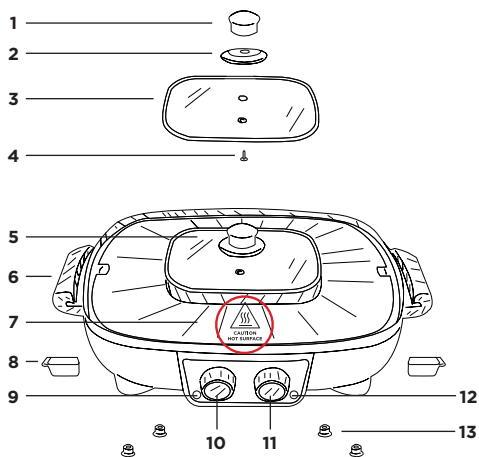

1. Glass lid handle
2. Glass lid handle washer
3. Glass lid
4. Glass lid handle screw
5. Hotpot (in middle)
6. Handles
7. Grill
8. Oil tray
9. Temperature indicator light for grill

10. Temperature control dial for grill
11. Temperature control dial for hotpot
12. Temperature indicator light for hotpot
13. Rubber grips

Safety Instructions

- Read all instructions thoroughly before first use, even if you are familiar with this type of product. Keep this manual in a safe place for future reference. If applicable pass these instructions on to the next owner of this appliance.
- This appliance is intended for private domestic use only. It is not suitable for commercial, industrial or trade use. Do not use it outdoors.
- This appliance is intended to be used in household and similar applications such as:
 - Staff kitchen areas in shops, offices and other working environments
 - Farm houses
 - By clients in hotels, motels and other residential type environments
 - Bed and breakfast type environments.
- Do not use the appliance for anything other than its intended purpose and only use it as described in this manual. Any other use is not recommended and may cause fire, electric shock, or injury.
- Do not use accessories that are not supplied with this appliance. The use of accessories that are not recommended or sold by the manufacturer can cause fire, electric shock, or injuries.
- Do not use the appliance in the close vicinity of flammable materials such as curtains, drapes, paper, wall coverings, tea towels or clothing. Do not use it under a cupboard or close to a wall as scorching may occur.
- This appliance is not intended for use by persons (including children) with

reduced physical, sensory, or mental capabilities or lack of experience and knowledge, unless they have been given supervision or instruction concerning the use of the appliance by a person responsible for their safety.

- Close supervision is necessary when any appliance is used by or near children. Ensure children do not play with the appliance. Keep the appliance and its cord out of reach of children under 8 years old.
- Ensure your outlet voltage and circuit frequency correspond to the voltage stated on the appliance rating label. If it does not match, do not use the appliance.
- Insert the plug securely into a properly earthed mains socket that is within reach so the plug can be easily removed if necessary.
- Do not connect the appliance to an external switching device such as an external timer or a separate remote-control system.
- To reduce the risk of electric shock, do NOT immerse the cord, plug or appliance in water or other liquids when cleaning. If it falls into water, immediately unplug it from the electrical outlet. Do not touch it or reach into the water.
- Do not use the appliance or touch the plug with wet or damp hands, on a damp floor or when the appliance itself is wet. Do not spill liquids on the product.
- Do not insert any objects into the appliance. Do NOT use appliance if damaged.
- Do not kink, squash, or strain the power cord and protect it from sharp edges and heat, including hot cooking surfaces when in use. Do not place anything on top of the cord.
- Do NOT wrap the cord around the appliance, and never pull the cord to lift, carry or unplug the appliance.

If winding the power cord, avoid tight bends as this could damage the cord.

- A short power cord is provided to reduce the hazards resulting from entanglement or tripping over a longer cord. If it is necessary to use an extension cord, make sure it has been approved and has the same electrical rating (voltage and power) as the appliance (check the rating label). Arrange the extended cord so that it will not drape over the table or bench-top where it can be pulled on or tripped over accidentally.
- The connector (cable) must be removed before the appliance is cleaned and the inlet must be dried before the appliance is used again.
- Check the power cord regularly for visible damage. If it is damaged, do not use the appliance. A damaged cord must be replaced by the manufacturer, its authorised service centres or similarly qualified personnel to avoid any hazards.
- Always turn the power off at the power outlet before you insert or remove a plug. Unplug the appliance before cleaning, servicing, maintenance or moving the appliance and after use. Grip the plug when disconnecting, do not pull on the cord.
- To disconnect, turn the temperature controls to the lowest setting, then turn off at the wall outlet and remove the plug from wall outlet. Always unplug the appliance after use and wait until it has completely cooled before cleaning, maintenance or moving the appliance.
- CAUTION:



Hot surfaces! The heating element surface is subject to residual heat after use. Use oven mitts or potholders when handling appliance. Do NOT place anything on top of the appliance while it is in use or still hot.

- To ensure efficient operation and avoid overturning, always place the appliance on a level, stable, heat- and flame-proof work surface. Do not use it on an inclined plane or unstable surface. Always ensure there is sufficient free space above and around all sides of the appliance for air circulation.
- Do not place the appliance on or near a hot gas or electric stove/cooktop, or near a heated oven.
- Do not move the appliance while it is in use. Do not cover it when it is in use. To prevent food from burning, ensure to monitor the cooking process when using the appliance.
- Only use wooden, silicone or heat-resistant plastic utensils to remove foods from the cooking pot of the appliance. Do not use metal utensils to avoid scratching the non-stick surfaces.
- Do not leave any cardboard, plastic, paper or similar in the appliance.
- The appliance has non-user-serviceable parts contained inside. Do not attempt to repair, disassemble, or modify it yourself.

Packaging and Recycling

The materials used for this product's packaging can be reused, recycled, and disposed of through specific waste streams.

- REUSE: Keep packaging to safely store or transport your appliance, preventing damage.
- RECYCLE: Look for recycling symbols on packaging components to identify if they are recyclable. Check with your local authority to find out what materials are accepted for recycling in your area.
- DISPOSE: Look for symbols on packaging components and dispose of materials accordingly.

Technical Information

Voltage supply	220-240V- 50/60Hz
Power consumption	1700W
Soup pot capacity	1.5L

Before First Use

- Carefully unpack the appliance and remove any packaging.
- Wipe the appliance inside and out with a soft damp cloth and dry thoroughly.
- Before use, ensure the socket plug and the steamboat hotpot & grill are suitable for use in your kitchen outlet. After plugging in the appliance, adjust it to medium heat for about 30 minutes, then turn off the switch, unplug the power supply, and check whether the temperature of the dial is too high to avoid danger caused by excessive heat.
- When the appliance is heating for the first time, it may emit a slight smoke or odour. This is normal with heating appliances. Ensure there is adequate ventilation around the appliance. This does not affect the safety of your appliance.

Assembly Instructions

- The lid for the hotpot needs to be assembled before use. Remove the screw and silicone ring from the handle and place the handle on the top of the glass lid.
- Then from the bottom of the lid, place the silicone ring and then the screw to secure the handle to the lid.
- Fasten the screw with a screwdriver in a clockwise direction ensuring not to overtighten the screw.
- Place the 4 rubber grips to the base of the appliance. Ensure they are slotted securely in place.

- Slot the oil tray in the grooves on both sides of the appliance until it is fixed into place.

Operating Instructions

- Place the appliance on a level, stable and heat-resistant surface.
- Season the cooking surface by applying a thin coat of cooking oil and rub in with a paper towel.
- Ensure the dial is set to Min before plugging in. Connect the appliance to a power outlet and turn on.
- Set the hotpot and/or grill temperature control dials to your desired temperature settings.
- Place your food on the grill or in the hotpot and cook as required/recommended.
- Once you have finished cooking your food, turn the appliance off by turning the temperature control dials to the left position and then unplug the appliance from the power socket.
- The indicator lights will cycle on and off during the cooking process. This is to show that the cooking surface is maintaining the set temperature.

For Hot Pot Boiling

- Pour the prepared soup or broth into the hotpot and cover it with the lid.
- Plug in the power and turn on the appliance, then adjust the temperature according to your need.
- After about 10–15 minutes or after the water boils, lift the lid and add your pre-prepared ingredients to the hotpot and replace the lid.
- **CAUTION:** A lot of hot steam will be emitted when the hotpot lid is lifted. Take extreme care to protect yourself from steam burns or hot splashing water or overflows.
- After the hotpot reaches a certain temperature, the grill indicator light will turn off automatically. When the temperature of the hotpot drops to

a certain level, the indicator light will automatically power on and start heating the appliance again. After use, turn the dial to the left to power off the appliance.

For Hot Grill

- Apply a little cooking oil to the grill, and carefully place the food you want to be cooked. Ensure to periodically turn food for an even grill.
- Clean any residue on the grill to prevent food from being burnt. After use, turn the dial to the left position to power off the appliance.

Care Instructions

- Clean the appliance after every use and before storage.
- There is a non-stick coating on the hot plate. Do not use metal utensils or abrasive cleaning materials to clean them, as this may damage the nonstick coating.
- Unplug the appliance from the power socket and allow the appliance to cool completely before cleaning.
- Do not let water enter the oil drip holes, power socket or electrical parts. Wipe the outside of the unit housing with a damp cloth. Do not immerse the unit housing in water or any other liquid and do not rinse under running water.
- Clean the oil drip tray after every use in warm soapy water and dry thoroughly before storing.
- To clean the hotpot and grill, wipe with a damp sponge. Take care not to let water drip over the edge of the grill. Rinse with a clean cloth to ensure there is no detergent residue remaining.
- Ensure the glass lid is cool before attempting to clean it. Trying to clean a hot or warm glass lid may shatter the glass. Wash with warm soapy water and allow to dry thoroughly.

- Do NOT place this appliance or accessories in the dishwasher.
- All parts must be completely dry before being stored. Always store the appliance in a dry and clean area. Protect the appliance from direct sunlight and keep out of reach of children.

Recipes

Vietnamese Steamboat

Serves 4.

Ingredients:

For the broth

- 1½ litres good free-range chicken stock
- 2 tbsp rice wine
- 3 lemongrass stalks, bruised
- 3 garlic cloves, crushed
- 3 cm piece ginger, thinly sliced
- 2 spring onions, thinly sliced diagonally

For the dipping sauce

- 1-2 red chillies, de-seeded and finely chopped
- 1 garlic clove, crushed
- 1 tbsp sugar
- ¼ cup freshly squeezed lemon or lime juice
- 1 tbsp rice vinegar
- 2 tbsp fish sauce

For the chicken marinade

- 1 tbsp oyster sauce
- 1 tbsp soy sauce
- 1 tbsp rice vinegar
- ½ tsp sesame oil
- 1 garlic clove crushed
- 600g free range skinless chicken breast, thinly sliced

For the steamboat additions

- 12 raw prawns, shelled
- 150g silken tofu, cubed
- Fresh Asian greens

- Sliced Chinese cabbage
- Asparagus
- Bean sprouts
- Sliced celery
- Sliced mushrooms
- Fresh coriander
- Thai basil
- Vietnamese mint
- 300g fresh egg noodles

Method:

1. To make the broth, put all ingredients in hotpot and bring to a boil. Simmer for 20 minutes.
2. To make the dipping sauce, add all ingredients to a bowl and stir with a fork until the sugar has dissolved. Set aside until required.
3. To prepare the chicken, place oyster sauce, soy sauce, rice vinegar, sesame oil and garlic in a bowl. Add sliced chicken and mix well, making sure the chicken is well coated.
4. Arrange your chosen steamboat additions onto platters.
5. Place the appliance in the centre of the table and allow guests to poach their steamboat options in the broth, ensuring any chicken or prawns are fully cooked through. Dip into dipping sauce.
6. When poaching is complete, add noodles to broth and simmer until cooked. Ladle broth and noodles into serving bowls and eat straightaway.

Tom Yum Steamboat Broth

(This flavoursome broth can be used as an alternative to the broth described in the recipe above).

Serves 4.

Ingredients:

- 1 litre water
- 1 litre good free range chicken stock
- 2 stalks lemongrass, smashed
- 2 cm ginger, peeled and chopped

- 8 pieces lime leaves
- 1 green onion, sliced
- 4 Thai red chillies, sliced
- 4 tbsp Tom Yum paste
- 4 tbsp fish sauce
- 2 tbsp milk

Method:

1. In the hotpot, combine water, chicken stock, lemongrass, ginger, lime leaves, green onion, chillies and bring to a boil.
2. Lower heat to a simmer and add Tom Yum paste, fish sauce and milk.
3. Allow to simmer until flavours develop, then serve.

Laksa Hotpot

Serves 4.

Ingredients:

For the broth

- 1.6 litres water
- 400ml coconut milk
- 2 tbsp fish sauce
- 200g laksa paste

Additions

- 16 prawns
- Packet of baby corn
- Firm tofu, sliced
- Snow peas and capsicum as desired

Garnish

- 50g beansprouts
- 1 red chilli, finely diced (remove seeds for less heat)

Method:

1. Add water, coconut milk, fish sauce and laksa paste to the hotpot and bring to a boil. Reduce heat and simmer until fragrant.
2. Grill prawns, baby corn and tofu for 3–4 minutes on high. Cook further if desired.
3. Use fresh snow peas and capsicum for extra crunch as desired.

4. Garnish with beansprouts and finely diced chilli.
5. Serve on a bed of jasmine rice.

Tofu Hotpot

Serves 4.

Ingredients:

- For the broth
- 1 litre vegetable stock
- 1 star anise
- 4 cm piece ginger, sliced
- 2 large garlic cloves, sliced
- 2 long red chillies, seeds removed, thinly sliced diagonally

Additions

- 300g dried thin rice or egg noodles
- 1 tsp sesame oil
- 1 tbsp peanut oil
- 200g firm tofu, cut into 2 cm pieces
- 100g enoki or thinly sliced shitake mushrooms
- 1 leek (pale part only), thinly sliced
- 2 bok choy, quartered
- 2 tbsp soy sauce

Garnish

- 2 spring onions, thinly sliced diagonally

Method:

1. Place stock, star anise, ginger, garlic and chilli in the hotpot. Set appliance to high heat and bring to a boil. Reduce heat to medium-low and simmer for 5 minutes to allow the flavours to infuse.
2. While broth simmers, place noodles in a bowl and cover with boiling water. Let stand for 2–3 minutes, drain, then toss with sesame and peanut oils. Set aside until needed.
3. Grill the tofu and mushrooms for extra flavour on the grill plate.
4. Add the leek and bok choy to stock. Simmer for 2–3 minutes or until vegetables are just cooked.

5. Add the soy sauce to broth.
6. Divide noodles, tofu, and vegetables among four bowls.
7. Ladle soup into bowls. Scatter the spring onion as a garnish and serve immediately.

Note: You can grill 2 x 200g sirloin steaks – trimmed and very thinly sliced. Conversely, poach the steaks, the heat from the soup will be enough to cook the beef.

Teppanyaki Beef Yakiniku

Serves 4.

Ingredients:

- 2 white onions
- 1 red capsicum
- 300g Japanese/Kent pumpkin
- 1 zucchini
- 16 mushrooms
- 2 tbsp vegetable oil
- 500g beef, thinly sliced

For the Yakiniku Sauce

- ¼ cup soy sauce
- 2 dried chilli peppers, sliced
- 2 tbsp sugar
- 2 tbsp mirin
- 1 tbsp grated garlic
- 1 tbsp grated ginger
- ½ tbsp ground sesame seeds
- 1 tsp sesame oil

To Serve

- 2 boiled eggs
- Handful coriander

Method:

1. To prepare the Yakiniku Sauce, add soy sauce, dried chilli peppers, sugar, mirin, garlic, ginger and sesame seeds to the hotpot. Bring to a boil while stirring.
2. Once boiling, add the sesame oil and cook for another 2 minutes.
3. Slice onions, capsicum, pumpkin and zucchini to 1 cm thick strips.

Cut stems off the mushrooms and slice to 1 cm thick.

4. Heat oil on the grill plate (set to high). Start grilling vegetables as these will take approximately 12 minutes to cook.
5. Add beef to the Yakiniku sauce to marinate.
6. After about 4 minutes of marinating, start cooking beef on the grill.
7. Turn vegetables and meat to ensure they cook evenly.
8. Serve on a bed of rice or noodles with half a boiled egg per bowl.
9. Garnish with coriander.

Thai Chicken Satay Skewers

Serves 4.

Ingredients:

- For the chicken skewers
- 600g skinless free-range chicken thighs, cut into 2cm pieces
- 1 tbsp curry powder
- 1 tsp white sugar
- 2 tsp red curry paste
- 1 tsp salt
- 60ml coconut milk
- Skewers

For the peanut sauce

- 2 tbsp red curry paste
- ¾ cup peanut butter
- ¼ cup white sugar
- 2 tsp dark soy sauce
- 1 tsp salt
- 2 tbsp apple cider vinegar
- ¾ cup water
- 340ml coconut milk

To Serve

- Jasmine rice
- 2 tbsp peanuts, finely chopped
- Finely sliced red chilli (de-seed for less heat)
- Lime wedges

- Handful coriander

Method

1. In a bowl, mix together chicken, curry powder, sugar, red curry paste, and 1 teaspoon of salt with ¼ cup of coconut milk. Set aside for at least 30 minutes (or overnight). Soak skewers if wooden.
2. Thread chicken onto skewers, maximum 5 pieces on each.
3. Turn on hotpot.
4. Place peanut sauce ingredients into hotpot over medium heat, stir to combine. Simmer, adjusting consistency with water if sauce gets too thick. Cover with lid and turn to low whilst chicken continues to marinate.
5. Turn on grill and wipe oil onto grill plate.
6. Cook chicken skewers on grill for approximately 3 minutes on each side until fully cooked through.
7. Serve with jasmine rice, chopped peanuts, chilli, lime and coriander.

English Breakfast

Serves 4.

Ingredients:

- Can of baked beans
- 4 rashers of bacon
- 4 eggs
- 2 large tomatoes, cut in half

Method:

1. Use the hotpot to warm your baked beans.
2. Start by cooking tomatoes on the grill. Then, place your bacon on to cook.
3. Using egg rings, fry eggs to your desired preference.
4. Serve with toast and a hot cup of coffee.

Our 12-Month Guarantee

In Australia, our goods come with guarantees that cannot be excluded under the Australian Consumer Law. You are entitled to a replacement or refund for a major failure and compensation for any other reasonably foreseeable losses or damage. You are also entitled to have the goods repaired if the goods fail to be of acceptable quality and the failure does not amount to a major failure.

We stand by this product and therefore, we offer a 12-month guarantee. The benefits of this guarantee are in addition to any rights and remedies imposed by the Australian Consumer Law. Our guarantee excludes normal wear and tear and instances where care and use instructions have not been followed.

What IsAlbi will do:

During this guarantee period, IsAlbi will repair, replace, or refund any defective product. If identical product is not available for replacement, a similar product may be offered. IsAlbi asks you to cover the cost of postage/transit if the product needs to be sent back to us for inspection. If IsAlbi deems the product is defective, we will reimburse your postage/transit expenses. IsAlbi will be responsible for the postage/transit of the repaired/replacement product back to you.

What to do:

If a fault/defect is identified, cease using the product immediately. To make a claim on this guarantee, take the product, proof of purchase, and full details of the alleged defect to the retailer from whom the product was purchased. If you cannot access the retailer or are unsatisfied with the solution offered by the retailer, contact IsAlbi via the details below.

IsAlbi

87 Chifley Drive, Preston, Victoria 3072

P: +61 (03) 9474 1300

E: enquiries@isalbi.com.au

isalbi.com.au