

DEVANTI®

FOOD DEHYDRATOR
MODEL: FD-E-383B-ST-BK



USER MANUAL

Please read this user manual carefully before using the product. Please retain this manual for future reference.

SPECIFICATIONS

Voltage:	220-240V, 50/60Hz
Power:	600W to 700W
Thermostat:	35°C to 70°C
Timer:	00:30 to 24:00 hrs

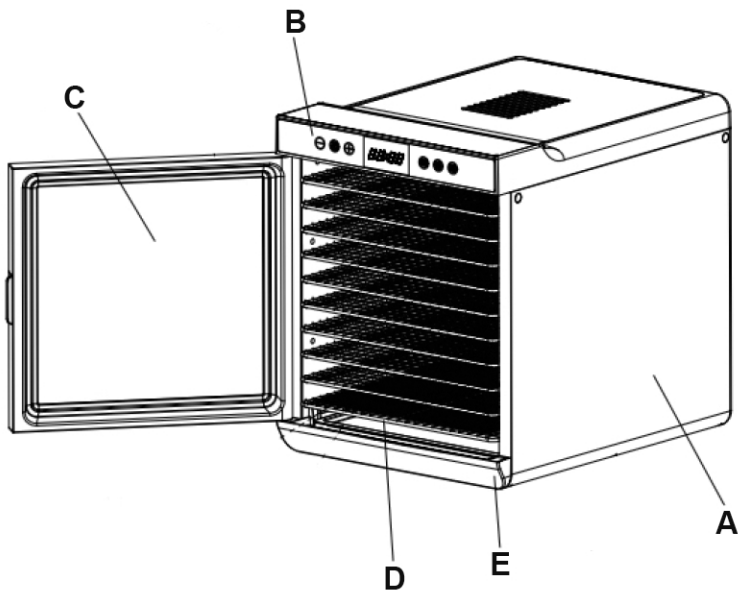

- A: Housing
- B: Control panel
- C: Transparent door
- D: Stainless steel tray
- E: Base

Illustrations may vary from actual product. Please refer to actual product for parts descriptions.

SAFETY INSTRUCTIONS

The following basic precautions should always be adhered to when using electrical appliances.

1. This appliance can be used by children aged 8 years and above and persons with reduced physical, sensory or mental capabilities or lack of experience and knowledge if they have been given supervision or instruction concerning use of the appliance in a safe way and understand the hazards involved. Children shall not play with the appliance.
2. Cleaning and user maintenance shall not be made by children unless that are older than 8 years old and supervised. Keep the appliance and its power cord out of reach of children below 8 years old.
3. This appliance is intended to be used in household and similar applications such as:
 - Staff kitchen areas in shops, offices and other working environments
 - Farm houses
 - By clients in hotels, motels and other residential-type environments
 - Bed and breakfast-type establishments
4. This food dehydrator is designed for domestic use only and is not suitable for commercial use. Do not use it outdoors.
5. When using the food dehydrator, ensure that it is on a flat, level and sturdy surface with no risk of it falling over. Consider the weight of the appliance during use.
6. Failure to follow all the instructions listed may result in electric shock, fire or serious personal injury. The warnings, cautions and instructions discussed in this user manual cannot cover all possible conditions and situations that may occur while the appliance is in use.
7. Do not leave the food dehydrator unattended during use.
8. Always keep the food dehydrator out of children as they are unable to recognise the hazards associated with incorrect handling of electrical appliances.
9. Before plugging in the food dehydrator into the mains electrical outlet, check that the voltage and power supply comply with the specifications on the rating label of the food dehydrator.

SAFETY INSTRUCTIONS

10. Make sure that the food dehydrator is switched off and the plug is removed from the mains electrical outlet when it is not in use, before cleaning and whilst it is being repaired.
11. Ensure that the power cord of the food dehydrator is not hung over sharp edges and kept away from hot objects and open flames. If not, the plastic of the power cord will melt and cause a fire.
12. Under no circumstances should the food dehydrator or power plug be immersed in water or any other liquid. Do not use the dehydrator with wet hands.
13. Check the food dehydrator and its power cord regularly for damage.
14. Do not use the food dehydrator if it or the power cord is damaged, following a malfunction, or after it has been dropped and damaged in any way.
15. If the power cord is damaged, it must be replaced by the manufacturer, its service agent or similarly qualified persons in order to avoid any potential hazard.
16. Repairs to the food dehydrator should only be performed by a qualified electrician. Improper repairs may place the user at risk.
17. None of the parts of the food dehydrator are dishwasher-safe, unless explicitly specified otherwise.
18. Always turn off the power at the mains electrical outlet before inserting or removing the power plug. Remove the power plug by grasping it. Do not pull the power cord to unplug.
19. Do not use the appliance with an extension cord unless the cord has been checked and tested by qualified service personnel.
20. Never use an unauthorised attachment.
21. Avoid contact with moving parts. Keep hands, hair, clothing, spatula and other utensils away during operation to reduce the risk of injury to persons or damage to the appliance.
22. Do not face the exhaust of the appliance towards any person. Do not place anything beside the appliance to avoid any fire hazard.

CAUTIONS

- To reduce the risk of electrical shock, do not immerse or expose the appliance, power cord or power plug to rain, moisture or any liquid.
- Do not use the appliance near baths, basins or other vessels containing water or other liquids, or when standing in or on damp or wet surfaces. Do not keep the appliance in wet or watery environments.
- Keep the appliance away from UV rays and high temperature environments.
- Do not operate the appliance with wet hands.
- In the event that the appliance is dropped in water, turn off the power at the mains electrical outlet and remove the power plug immediately.
DO NOT REACH INTO THE WATER TO RETRIEVE THE APPLIANCE.
- It is important to note that the appliance will have to be inspected by a qualified service technician before using it again.
- Do not run the appliance for more than 24 hours in one single use. After 24 hours, unplug and let the appliance cool down for at least 2 hours before operating it again.
- Do not operate the appliance near aerosol cans.
- Incorrect operation and improper handling can lead to malfunction of the appliance and injuries to the user.
- The power cord should not be subject to any pressure by heavy or sharp objects. Otherwise, it may cause a fire or electric shock.
- The temperature of the accessible surface may be high when the appliance is in operation.
- The appliances are not intended to be operated by means of an external timer or separate remote-control system.

FOOD DEHYDRATOR BENEFITS

This food dehydrator features an automatic fan that circulates warm air evenly to produce nice and thorough drying. Dried snacks are healthy because they retain almost all their nutrients and flavour.

- Perfect way to preserve fruits, vegetables, bread, flowers and more.
- Ten stainless steel trays that have a weight capacity of 500g each.
- Trays can be removed to make space for thicker foods.
- Easy cleaning and maintenance of the trays.

BEFORE USE

CLEANING

Before using the food dehydrator for the first time, wipe all parts of the appliance with a dry cloth. Clean the stainless steel trays and transparent door with a damp cloth. Use a mild detergent as needed. Do not hose or immerse the food dehydrator in water or any other liquids.

After cleaning, run the appliance for 30 minutes without placing any food inside the appliance. Smoke or smells produced during this run-in procedure is normal. Please ensure sufficient ventilation. After the run-in period, rinse the trays in water and dry all parts. This procedure is only necessary for first-time use.

Unplug the food dehydrator from the mains electrical outlet and let it cool down before storing the food dehydrator.

Do not clean the food dehydrator with harsh or abrasive chemicals in order not to damage the surface finishes.

Ensure that the food dehydrator sits steadily on a solid and level surface. Stack the drying trays and plug in the power plug. The food dehydrator is now ready for use.

OPERATING INSTRUCTIONS



1. Place the clean food in the trays. Do not overload the trays and never overlap the food. Close the door.
2. Plug in the food dehydrator to the mains electrical outlet and an alert sound will be heard. The display screen will come on and all the buttons will be lighted up. After 3 secs, the TIME/TEMP button will start to flash and the lighting with all other buttons will go off. This signals the food dehydrator is in standby mode.
3. While in standby mode, press the TIME/TEMP button. All the buttons will light up again. From here, you can set the temperature, time, keep warm and fast/raw functions. After setting the relevant functions, press the START/STOP button and the appliance will start to operate. If the settings are made and the START/STOP button is not pressed within 5 seconds, the food dehydrator will revert to standby mode.

DEFAULT SETTINGS

TEMP

The food dehydrator default temperature is 70°C and the temperature range is from 35°C to 70°C. Each temperature setting interval is 5°C.

TIME

The food dehydrator default drying time is 10 hours. The time range is from 00:30 to 24:00 hrs. Each time setting interval is 30 minutes.

TEMPERATURE SETTING

Press the TIME/TEMP button and the temperature in the display screen will begin to flash. If the time function flashes instead, press the TIME/TEMP button again.

- Press the '+' or '-' button to set the desired temperature.
- Hold down the '+' or '-' button to get to the desired temperature faster. The temperature range is from 35°C to 70°C.

OPERATING INSTRUCTIONS

TIME SETTING

Press the TIME/TEMP button and the time in the display screen will begin to flash. If the temperature function flashes instead, press the TIME/TEMP button again.

- Press the '+' or '-' button to set the desired time.
- Hold down the '+' or '-' button to get to the desired time faster. The time range is from 00:30 to 24:00 hours.

During the drying process, you can change or check the temperature. Press the TIME/TEMP button first and then the '+' or '-' button. Press the START/STOP button and all functions will be paused.

FAST/RAW SETTING

Fast mode: Temperature 70°C. Time 10 hours. Display screen shows FAST.
Raw mode: Temperature 45°C. Time 24 hours. Display screen shows RAW.

KEEP WARM SETTING

This is an optional function. Press the KEEP WARM button and the display screen will show KEEP WARM. The food dehydrator will continue to operate beyond 24 hours at 35°C after finishing drying.

If time has elapsed, the display screen will show 88:88 and the heating element will turn off. The fan will continue to run for 10 seconds and the appliance will beep for 20 times to signal that drying has been completed. The food dehydrator will revert to standby mode.

NOTE: Set lower temperature for thin/small pieces or for a small load of food. Likewise, set the temperature higher for thick/large pieces of food or larger loads. The thermostat can be used to decrease or increase the temperature as the food is near to the end of its drying cycle. This makes it easier to control the final moisture level in the dried food.

NOTE: Make sure that the fan base is always in place when operating the dehydrator. If the food cannot be dried in one day, continue drying the next day. as such, place the partially dried food in a container or polyethylene bag and place it in the freezer.

Once drying is done, unplug the appliance from the mains electrical outlet.

DRYING TIPS

- This food dehydrator includes 10 trays and an overheat protection. The appliance contains heating elements, motor, fan and thermostat.
- The air vents on the trays allow air to be circulated.
- With its controlled heat temperature, the dehydrator allows air to back flow into each tray.
- Depending on the moisture level in the food itself and the humidity in the air, the operating drying time can change. Use the dehydrator in a dust-free, well-ventilated, warm and dry room. Ample air ventilation is also important.
- Fruits and vegetables dried in a food dehydrator will be different in appearance from those sold in health food stores and supermarkets. This is because the food dehydrator does not use any preservatives or artificial colouring when drying. Only natural nutrients of the fruits and vegetables are present in the drying process.
- Keeping records of humidity and weight of food before and after drying will be helpful to improve drying temperatures for future reference.

Drying times for pre-treatment of fruits vary according to the following factors:

1. Thickness of pieces or slices.
2. Number of trays with food being dried.
3. Volume of food being dried.
4. Moisture or humidity in the environment
5. Your preferences for drying each type of dried food

It is recommended to:

- Check your food every hour.
- Label food with contents dried, date and weight before drying. It will also be helpful to note the drying time for future reference.
- Pre-treated food will give the best effects in drying.
- Correct food storage after drying will also help to keep food in good quality and save the nutrients.

STORAGE

- Store food only after they have cooled down.
- Food can be kept longer if stored in a cool, dry and dark place.
- Remove all air as much as possible from the storage container and close it tightly.
- Optimal storage temperature is 15°C or lower.
- Never store food directly in a metal container.
- Avoid containers that 'breathe' or have a weak seal.
- Check the contents of the dried food for moisture during the weeks following dehydration. If there is moisture inside, dehydrate the contents for a longer period to avoid spoiling the food.
- For best quality dried fruits, vegetables, herbs, nuts and breads, they should not be kept for more than one year if kept in a refrigerator or freezer.
- Dried meats, poultry and fish should be stored for not more than 3 months if kept in the refrigerator, or one year if kept in the freezer.

CLEANING AND MAINTENANCE

After using the food dehydrator, unplug it from the mains electrical outlet and let it cool down before cleaning.

Use a soft brush to remove any food residues sticking to the trays.

Dry all parts with a dry cloth before storing the food dehydrator.

Clean the surface with a wet cloth.

Use paper towels to remove any excess marinade.

Do not clean the appliance with aggressive chemicals or abrasives in order not to damage surface finishes.

The user manual can also be check and download from our email: compliance@newaim.com.au