

DEVANTI

Food dehydrator

Instruction Manual



PLEASE READ THIS INSTRUCTION CAREFULLY BEFORE USING THE PRODUCT

Technical specification:

Normal Voltage: 220 – 240V~50 – 60Hz

Normal Power: 600 – 700W

Thermostat: 35°C – 75°C

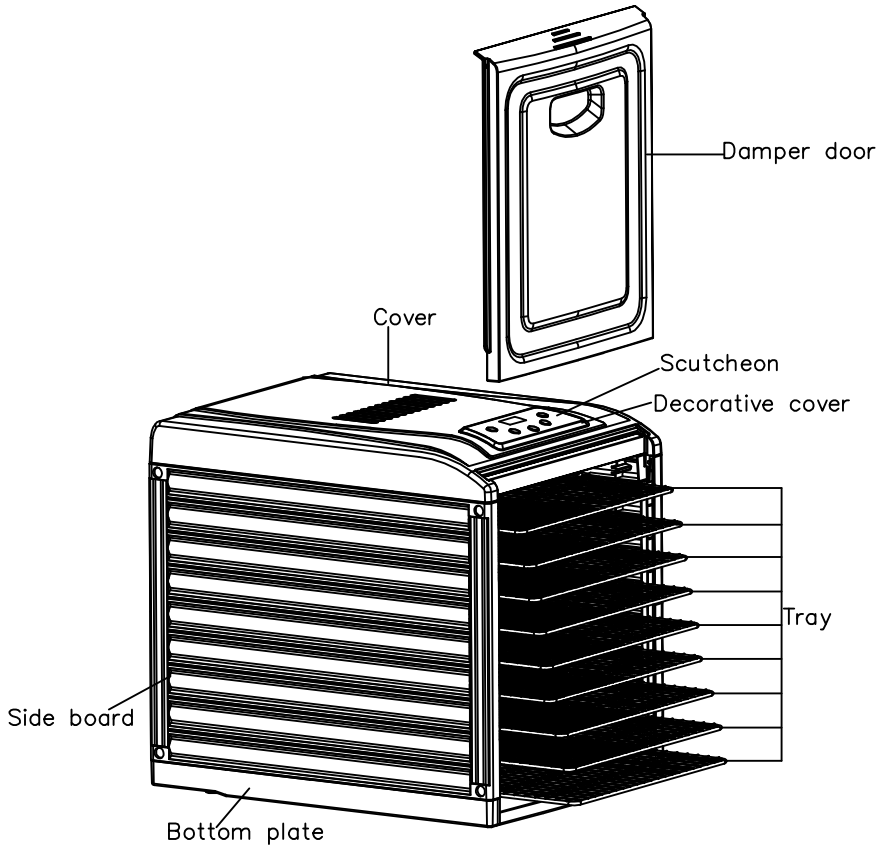

Getting started

Remove any packing from the product.

Place the packing inside the box and either store or dispose of responsibly

Safety Instruction

The following basic precautions should always be adhered to when using the electrical appliance

PLEASE READ THIS INSTRUCTION CAREFULLY BEFORE USE AND RETAIN FOR FUTURE REFERENCE

1. This appliance can be used by children aged from 8 years and above and persons with reduced physical, sensory or mental capabilities or lack of experience and knowledge if they have been given supervision or instruction concerning use of the appliance in a safe way and understand the hazards involved. Children shall not play with the appliance. Cleaning and user maintenance shall not be made by children unless they are older than 8 and supervised.
Keep the appliance and its cord out of reach of children less than 8 years. This appliance is intended to be used in household and similar applications such as:
 - staff kitchen areas in shops, offices and other working environments;
 - farm houses;
 - by clients in hotels, motels and other residential type environments;
 - bed and breakfast type environments.
3. This food dehydrator is designed for DOMESTIC USE ONLY and is not suitable for commercial use. Do not use it for outdoors.
4. When using the food dehydrator ensures that it is on a flat, level and sturdy surface, ensure no risk that it may fall. Also that it can take the weight of the unit during use.
5. Failure to follow all the instructions listed may result in electric shock, fire or serious personal injury. The warnings, cautions and instructions discussed in this instruction manual cannot cover all possible conditions and situations that may occur while the product in use
6. Do not leave the food dehydrator unattended during use.
7. Always keep the food dehydrator out of children as they are unable to recognize the hazards associated with incorrect handling of electrical appliances.
8. This appliance is not intended for use by persons (including children) with reduced physical, sensory or mental capabilities, or lack of experience and knowledge. Unless they have been given supervision or instruction concerning use of the appliances by a person responsible for their safety.
9. Before plugging the food dehydrator into the mains electrical supply, check that the voltage and power supply comply with the specifications on the food dehydrator's rating label.
10. Make sure that the food dehydrator is switched off and remove the plug from the mains electrical supply when it is not in use; before it is cleaned and whilst it is being repaired.
11. Ensure that the food dehydrator and power cord is not hung over sharp edges and keep away from hot objects and open flames; otherwise the plastic will melt and cause a fire.
12. Under no circumstances should the food dehydrator or plug be immersed in water or any other liquid. Do not use the appliance with wet hands.



13. Check the food dehydrator and power cord regularly for damage.
14. Do not use the food dehydrator should there be damage to the plug or cord, following a malfunction, or after it has been dropped or damaged in any way.
15. If the supply cord is damaged, it must be replaced by the manufacturer, its service agent or similarly qualified persons in order to avoid a hazard.
16. Repairs to the food dehydrator should only be performed by a qualified electrician .Improper repairs may place the user at risk.
17. None of the product's parts are dishwasher safe, unless explicitly specified otherwise.
18. Always turn the power off at the power outlet before you insert or remove a plug. Remove by grasping the plug; do not pull on the cord.
19. Do not use your appliance with an extension cord unless this cord has been checked and tested by a qualified technician or service person.
20. Never use an unauthorized attachment.
21. Avoid contact with moving parts. Keep hands, hair, clothing, spatulas and other utensils away during operation to reduce the risk of injury to persons and/or damage to the machine.
22. Please don't turn the draught of engine towards others or tinder.
23. Please don't keep it beside anything heating. Please keep the plug away from pressing; otherwise it will cause a fire or electric shock.
24. If you pass this appliance on to a third party, these operating instructions must also be handed over.

Caution:

- To reduce the risk of electric shock, do not immerse or expose the product, flexible cord or plug to rain, moisture or any liquid.
- Do not use the product near baths, basins or other vessels containing water or other liquids, or when standing in or on damp or wet surfaces. Don't keep the device in the watery environment.
- Keep the device away the place of high temperature、 ray and wetly.
- Don't operate the device with wet hands.
- Please turn off the power supply in the watery environment.
- In the event where the appliance is dropped into the water, turn off the power at the power outlet and remove the plug immediately. **DO NOT REACH INTO THE WATER TO RETRIEVE IT.**
- It is important to note that the appliance will have to be inspected by a qualified technician before using it again.

- **ATTENTION!** Do not run the appliance for more than **19 hours and 30 mins** in one single use. After **19 hours and 30 mins**, unplug and let it cool down for at least 2 hours before operating again.
- Do not operate near gas spray cans.
- Incorrect operation and improper handling can lead to malfunction of the appliance and injuries to the user.
- The power cord can not be squeezed by something heavy or sharp, otherwise it will cause a fire or electric shock.
- The temperature of accessible surface may be **HIGH** when the appliance is operating.

Feature of Dehydrator:

This unit features an automatic fan, which circulates warm air producing a nice evenly dried device!

Dried foods are a great treat to snack on because they hold almost all of their nutritional value and flavor.

- * Perfect way to preserve fruit, snacks, vegetables, bread, flowers and more.
- * See through safety door to view the drying process easily.
- * With nine trays, each tray can't load more than 0.5kgs of food.
- * It can remove one or more trays to increase the space for thicker food

Before Use

● Cleaning:

Before using the first time, wipe all parts of the appliance. Clean the 6 trays, damper door with a lightly moistened cloth. Use detergent as needed. Don't put the main engine into water or other liquids!

After cleaning, the unit must be run for 30 minutes without placing any food for drying during this period. **Any smoke or smells produced during this procedure are normal. Please ensure sufficient ventilation.** After the running in period, rinse the racks in water and dry all parts. This act is only necessary for the first time, but don't put the main engine into water or other liquids.

Unplug the dehydrator from the power supply and let it cool down before cleaning. Use a soft brush to remove food sticking. Dry all parts before storing the dehydrator.

Do not clean the appliance with aggressive chemicals or abrasives in order not to damage the surface.

WARNING! Do not spill or allow liquid, including marinade, to drip into the base of the unit as it may damage the product.

● Assembling the appliance:

Make sure that the dehydrator on a level surface. Stock the drying trays and connect the plug with a wall socket. The dehydrator is now ready for use.

Usage Method:

1. Put the clean food in the trays – Do not overload the trays and never overlap the food. Close the damper door.

2. Plug dehydrator into wall outlet. There is a beep sound at the beginning when it starts up.

Press the “ON/OFF” button, The LED screen will show default time setting “10:00” and temp setting “70°C”. Motor and fan start first, then heating element start working 5 seconds later. Set time begins to count down, the signal “:” on LED screen flashes.

3. Press the “TIMER” button and LED screen shows the time value. According to actual needs, press “+” or “-” button to change the drying time between “0:30” and “19:30”. Press “+” or “-” button once, the time increment or decrement is 30 minute/press. If press “+” or “-” button for long time, then it automatically increases or decreases. 3 seconds after finish setting the drying time, system automatically gets into operating mode in current time setup.

4. Press the “TEMP” button and LED screen shows the temp value. According to actual needs, press “+” or “-” button to change the drying temp between “35°C” and “70°C”. Press “+” or “-” button once, the temp increment or decrement is 5°C/press. If press “+” or “-” button for long time, then it automatically increases or decreases. 3 seconds after finish setting the drying temp system automatically confirms to work in current temp setup. LED screen operating in time mode.

Note: Set low temperature for thin/small pieces of food or for a small load of food. Set high temperature for drying thick/big pieces of food and large loads. The thermostat can also be used to decrease the temperature as the food is near the end of its drying cycle making it easier to control the final moisture level in the food.

5. During drying process, you can change or check the drying time. Press the “TIMER” button first, then press the “+” or “-” button. Press “TIMER” button, you can check the setting time.

6. During drying process, you can change or check the drying temp. Press the “TEMP” button first, then press the “+” or “-” button. 5 seconds after finish changing or checking, LED screen changes to time mode.

7. During drying process, press the “ON/OFF” button, all functions will be paused. Screen no display.

8. In standby mode, you can press the “ON/OFF” button directly to get into default mode (TIME : 10 hours TEMP: 70°C). You also can change the drying time and temp if needed.

9. Function buttons as below:



10. When the set time counts down to "0:00", the heating element stops working first. The fan will continue running for 10 seconds and the buzzer rings 20 times "beep" sound (1 time/second). The LED screen display signal "End" means finish drying..

Note: Make sure that the fan base is always in place when operating the dryer. If you do not have time to dry all the food in one day, you can dry them the next day. In this case, you should store the food in a container/polyethylene bag and put it in the freezer.

11. Unplug the unit from the power point.

Hints:

· This dehydrator includes 9 drawer trays and an overheat protection. The main engineer contains heating elements, motor, fan and thermostat.

· The air vents on the tray allow air to be circulated.

· Using a controlled heat temperature, Air from the back flow into each tray drying moisture..

· Depending on the moisture in the food itself and the humidity in the air, drying operation time can change.

Use the dryer in a dust free, well ventilated, warm and dry room. Well air ventilation is also important.

· Fruit and vegetables dried in your food dehydrator will be different in appearance from those sold in health food stores and supermarkets. This is due to your food dehydrator uses no preservatives, no artificial coloring and only natural additives.

· Records of humidity, weight of produce before and after drying times, will be helpful to improving your drying techniques for the future.

DRYING TIPS:

Drying time for pre-treatment fruit will vary according to the following factors:

- 1) thickness of pieces or slices
- 2) number of trays with food being dried
- 3) volume of food being dried
- 4) moisture or humidity in your environment
- 5) your preferences of drying for each type of dried food

It is recommended to:

- Check your food every hour.
- Label food with contents dried, date and weight before drying. It will also be helpful to note the drying time for future reference.
- Pretreated food will give the best effect in drying.
- Correct food storage after drying also will help to keep food in good quality and save the nutrients.

STORAGE

- Store food only after they have cooled down.
- Food can be kept longer if stored in a cool, dry and dark place.
- Remove all the air you possibly can from the storage container and close tightly.
- Optimal storage temperature is 15°C or lower.
- Never store food directly in a metal container.
- Avoid containers that "breathe" or have a weak seal.
- Check the contents of your dried food for moisture during the weeks following dehydration. If there is moisture inside, you should dehydrate the contents for a longer time to avoid spoiling.
- For best quality, dried fruit, vegetables, herbs, nuts, bread should not be kept for more than 1 year, if kept in the refrigerator or freezer.
- Dried meats, poultry and fish should be stored for no more than 3 months if kept in the refrigerator, or 1 year if kept in the freezer.

Maintenance/Cleaning Method:

- After using, unplug the dehydrator from the power supply and let it cool down before cleaning. Use a soft brush to remove food sticking on the trays.
- Dry all parts with a dry cloth before storing the dehydrator.
- Clean the surface of body with wet cloth.
- Use paper towels to remove any excess marinade.
- Do not clean the appliance with aggressive chemicals or abrasives in order not to damage the surface.

SAVE THIS INSTRUCTION !