

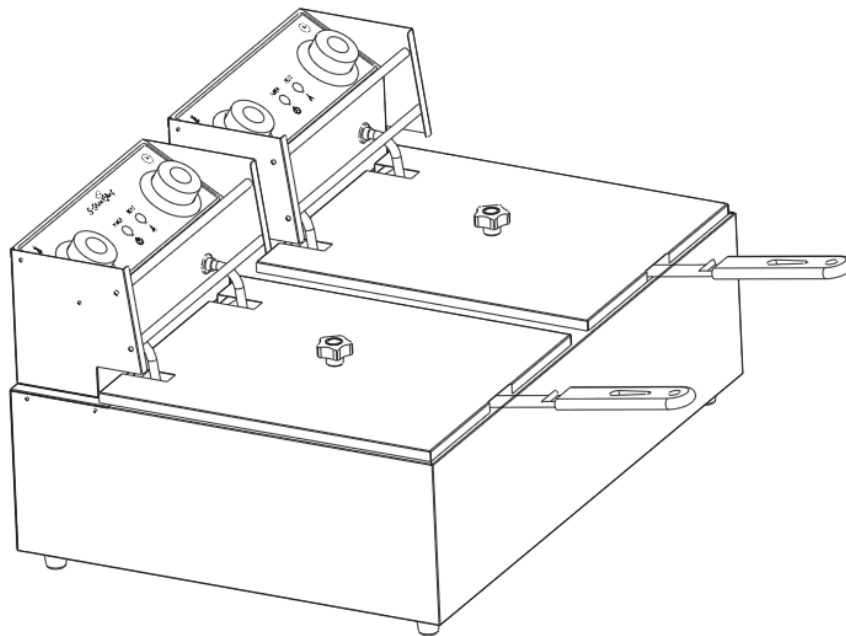

# 5-Star Chef

## Commercial Deep Fryer User Manual



- ★ All stainless steel construction
- ★ High-efficient, easy operable & safe
- ★ Durable and elegant design
- ★ C-Tick Certified  N16265

# **Index**

- I. Introduction**
- II. Technical Specification**
- III. Operating Instruction**
- IV. Maintenance & Cleaning**
- V. Cautions**
- VI. Circuit Diagram**

# 5 Star Chef Electric Deep Fryer

## I .Introduction:

Five Star Chef Electric Deep Fryer is a new kind of cooking product researched and developed lately by our company. This series of fryer adopt the internationally popular design, with high quality stainless steel body, is durable and good looking .The products are equipped with electrical elements from the quality suppliers to ensure to be energy-saving and safe .The rotating fryer head design is convenient, practical and easy for cleaning. They possess the advantages of thermostat function and is easy to operate. They are the best choice for families, take-away, café and restaurants, etc.

## II. Technical Specification:

Model	Voltage	Input Power (KW)	Capacity (L)	Capacity of Filling Oil (L)
CDF-D4C-DOUBLE	~240V,50HZ	2.5 + 2.5	10 + 10	7 + 7

## III. Operating Instruction:

Before using, please check whether the voltage of power supply is in conformity with that in the rating label, and whether your power switch and fuse are in conformity with the request of the machine's power. The body of the machine must be earthed properly.

### Operation Steps:

1. Fill edible oil into oil tank.
2. Make sure the temperature control knob and timer knob are positioned at "Zero".
3. Connect power supply and the green power indicator will be on. Turn on the power of the machine by adjusting temperature control knob clockwise to a suitable temperature. By the time being, yellow indicator is on and the heating element begins to heat. When reaching the set temperature, heating element stops heating up while the yellow indicator is off. When oil temperature decrease, the thermostat connects power supply automatically, yellow indicator will be on, and heating element begins heating again. This procedure is repeated to ensure oil temperature to keep on the set temperature range.
4. When reaching the set temperature, you can start to fry your food. You can also reset the thermostat temperature according to your needs. You can turn the timer knob to your preferred time when frying. When it reaches the set time, the fryer will ring for caution and cut off the power automatically.
5. Custom made frying basket for the fryer is provided. When you fry, please put the food into the basket then sink the basket into the oil. When you finish frying, please hang the basket on the rail of to filter the surplus oil.
6. The lid is designed to keep the tank clean and warm. Please make sure that there is no water on the lid when you cover.
7. After finish frying, lift up the electric control box backward by rotating it 90 ° to a self-locked vertical position.
8. The fryer is equipped with a safe switch. When you lift up the electric control box, the heating element is out of touch of the oil, then the safe switch will cut off the power automatically to avoid overheating.
9. After finishing frying, turn the temperature control knob anticlockwise to the Zero position, then cut off power for safety.

## IV. Maintenance & Cleaning:

Use wet cloth to clean after frying, Use neutral detergent to clean if necessary. Beware that electric

control box cannot be washed by water directly.

**V.Cautions:**

- DO NOT put explosive nearby the machine. Machine should be positioned in well-ventilated place.
- DO NOT make the heating element heating without oil.
- KEEP OUT of reach of children
- CUT OFF power supply after finishing frying.
- CUT OFF power supply before cleaning.
- DO NOT disassemble the machine unless by professional.

**Warning: Repeatedly fried oil has a lower flash point and will cause over boil easily; frying over-wet food or over frying would possibly cause accident.**

**Specifications:**

Model	Name Number	Electric Fryer	Frying Basket	Cylinder Head	User Manual
CDF-D4C-DOUBLE		2	2	2	1

**VII. Circuit Diagram:**

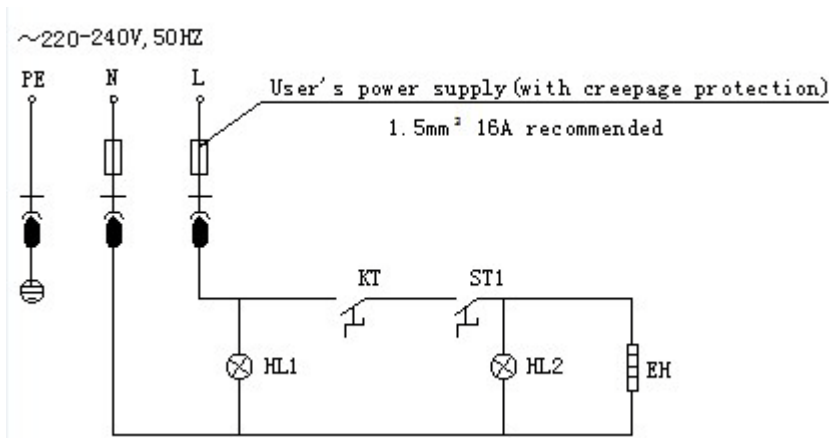

**ST1: Temperature Controller KT: Time controller HL1: Power Indicator HL2: Heating Indicator EH: Electric Heating Pipe**