

Healthy Choice[™]
AF720

DIGITAL AIR FRYER

7.1 LITRE COOKING BASKET



Model: AF720 | Batch: PR3942

This appliance is intended for household use only.

Please read and retain these instructions for future reference.

The illustrations used in the manual are to illustrate the operation method structure of the product. Where there is a small difference between the physical item and the illustrations, please take the physical as the standard.

ABOUT THE PRODUCT:

It is a beautiful summer's day – the kids are running around the backyard; the sun is beaming down on their excited faces until you hear that all-too-familiar sound: 'Mum! Dad! I'm hungry!'. You imagine throwing some frozen goodies into a magical machine, crisping and cooking them in minutes, ready to eat right away.

It's time to stop dreaming.

Our state-of-the-art multifunctional air fryer uses advanced 'turbo air' technology, mimicking what oil does to food when frying. Simply add your ingredients and wait as the air fryer circulates, 'superheated' air up to 200 degrees Celsius for a maximum time of 60 minutes. Enjoy seven convenient pre-set cooking programs including fries, chicken, prawn, cake, steak, fish ribs and keep warm.

This air fryer is easy to control – simply set the timer, set the temperature and walk away. Eliminating the extra cooking oil allows the family to enjoy healthy meals. Let the air fryer be your chef for the evening and enjoy the healthy, tasty results.

IMPORTANT SAFEGUARDS:

When using electrical appliances, basic safety precautions should always be followed, including the following.

1. Read instructions carefully before use.
2. Remove and safely disregard any packaging material and labels before using this product for the first time. Ensure children and babies do not play with plastic bags or any packaging materials.
3. Do not touch hot surfaces.
4. Before use, check that your local voltage corresponds with the specifications shown on the appliance nameplate located under the appliance.
5. Do not turn on power until this appliance and parts are in place as required. Make sure the door is closed before plugging and switching on the power.
6. To protect against electric shock, do not immerse the cord, plug, or this appliance in water or other liquid.
7. Close supervision is necessary when any appliance is used near children.

8. Unplug from outlet when not in use and before cleaning. Allow the appliance to cool down (if relevant) before putting on or taking off parts, and before cleaning the air fryer.

9. Do not operate the any appliance with a damaged cord or plug or after the appliance or is dropped or damaged in any manner, take it to the store where the appliance was purchased or call Lennox customer service for further assistance on 1300 666 848.

10. Do not use the appliance for other than intended use. It is for household use only. It is not to be used outdoors or for commercial purposes.

11. This appliance is intended to be used in household and similar applications such as:

-staff kitchen areas in shops, offices and other working environments;

-farm houses;

-by clients in hotels, motels and other residential type environments;

-bed and breakfast type environments

12. The air fryer should be operated on a separate electrical power point from other operating appliances. If the power point is overloaded with other appliances, this air fryer may not work properly.

13. Extreme caution must be used when moving an air fryer containing hot food.

14. Do not place on or near a hot gas or electric burner, or in a heated oven. Also keep away from the flammable material such as curtains, draperies when it is working.

14. Leave enough open space from other subject when in use.

15. Do not let cord hang over the edge of table or counter or touch hot surface.

16. Do not leave the cord hanging.

17. Do not unplug the air fryer by pulling on the cord.

18. Do not cover the air fryer while in use.

19. This appliance is not designed to be used by people (including children) with a physical, sensory or mental impairment, or people without knowledge or experience, unless they are supervised or given prior instructions concerning the use of the appliance by someone responsible for their safety. Children must be supervised to ensure that they do not play with the air fryer.

SHORT CORD INSTRUCTIONS:

Do not use with an extension cord. A short power supply cord is provided to reduce the risks resulting from being entangled in or tripping over a long cord.

PREPARATION FOR USE:

Before using the air fryer for the first time:

Warning: when using for the first time, the air fryer may emit slight odour which is not harmful and will disappear after a few minutes. This is because a protective oil was applied to protect parts from possible friction in transport.

Carefully unpack the air fryer and remove all the packing materials. Select a flat, heat-resistant Non-flammable surface to place the air fryer.

Use sponge and soapy water to remove any dust on the surface that may happen during packing and transport. Allow it to dry before use.

TECHNICAL SPECIFICATIONS:

Voltage :	220~240V
Power :	1700W
Frequency:	50~60Hz
Temperature Range :	80~200°C
Time setting Range :	1~60 min

CONSTRUCTION AND FEATURES:

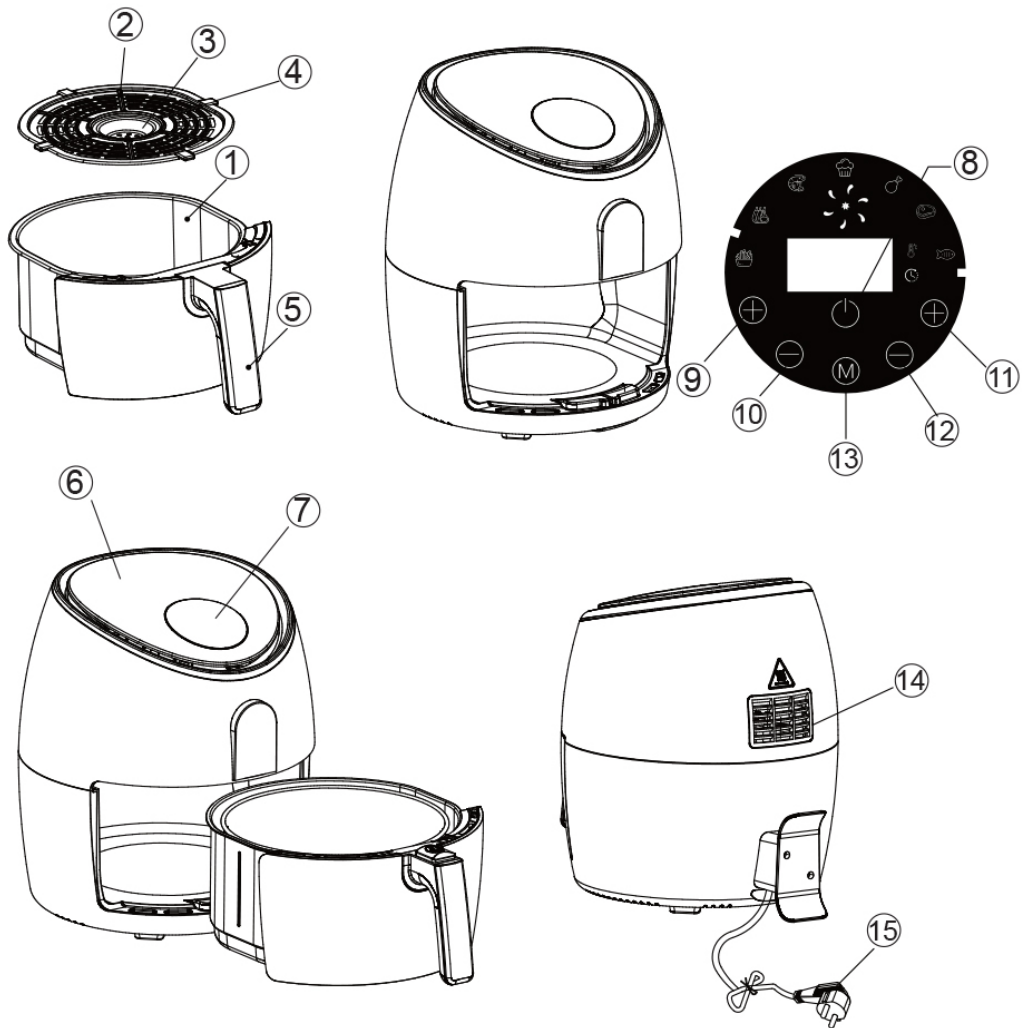

1. Frying basket
2. Grill plate
3. Grill plate grip handle
4. Silicone rubber (can stay on the grill plate during cooking)
5. Frying basket handle

6. Air inlet
7. Digital touch screen display

8. Power on button
9. Timer increase button
10. Timer decrease button
11. Temperature increase button
12. Temperature decrease button
13. Menu button

14. Air outlet
15. Power cord

USING THE AIR FRYER:

PRODUCT OPERATING INSTRUCTIONS:

1. When the power is connected, the air fryer will make a beep sound. The digital screen will light up and will then go off. The air fryer will be in sleep mode.

The POWER BUTTON  will remain illuminated.

2. Press the POWER BUTTON. The digital screen will light up and the air fryer will be in standby mode.
3. The default time is 15 minutes. The default temperature is 200 degrees.
To operate the air fryer at this time and temperature, press the POWER BUTTON.

Or

Press the MENU button  to choose a pre-set cooking function. Press the MENU button repeatedly to change between the 7 different options.

4. When your chosen selection is shown on the screen, press the POWER BUTTON.
The air fryer will start the cooking process.
5. The table below is a breakdown of the pre-set cooking times and temperatures:

		Default time (min)	Default temperature (°C)
Function	Fries	20	200°C
	Ribs	15	180°C
	Prawn	20	180°C
	Cake	40	160°C
	Chicken pieces	20	180°C
	Steak	20	180°C
	Fish	20	160°C

Note: if no button is pressed during the setting process for 60 seconds, the screen will go off and the air fryer will be in standby mode. Press the power button to turn it on.

SETTING A COOKING TIME AND TEMPERATURE:

You can manually set your own cooking time and temperature on the air fryer, when the unit is on and the screen is illuminated.

To set a cooking time:

Press the – and + positive buttons on the left-hand side of the control panel.

The time range is 1 – 60 minutes.

With every touch of the + / - buttons, the time will increase or reduce by 1-minute increments.

To set a temperature:

Press the – and + positive buttons on the right-hand side of the control panel.

The temperature control range is 80-200 ° C.

With every touch of the + / - buttons, the temperature will increase or reduce by 5 ° C increments.

When you have set your desired time and temperature, press the POWER button.

The air fryer will start the cooking process.

PAUSE FUNCTION:

To pause cooking, press the POWER button.

The power button will then blink on the screen.

Press it again to resume cooking.

During operation, you can take the frying basket out to shake ingredients/check cooking progress/add more food.

Operation will resume when the basket is added back to the air fryer.

If power is cut or the air fryer is unplugged during operation, the air fryer will be off. When power is resumed or the air fryer is plugged in again, operation will resume.

STOP COOKING:

To end cooking, press and hold the POWER button for 2 seconds.

COOKING END:

When the air fryer reaches the end of its cooking time, 00 will be shown on the screen and an audible timer alert will sound.

The fan will continue to operate for close to 30 seconds until the internal central temperature drops.

The air fryer will then enter standby mode.

OPERATION:

1. Plug the mains plug in an earthed wall socket.
2. Carefully pull the frying basket out of the air fryer. The grill pan needs to remain inside the frying basket.
3. Put the ingredients in the frying basket.

Note: *Never fill the frying basket beyond the Max amount indicated in the table shown in the section 'Settings', as this could affect the quality of the end-result.*

4. Slide the frying basket back into the air fryer.

Never use the frying basket without the grill pan in it.

Caution: *Do not touch the inside of the frying basket or grill pan during and about 30mins after use, as it gets very hot.*

Only hold the frying basket or by the handle.

5. Use one of the pre-set cooking programs or set your own time and temperature.
6. Press the POWER button to begin cooking.

·The timer starts counting down the set preparation time.

·Excess oil from the ingredients is collected at the bottom of the frying basket.

7. Some ingredients require shaking halfway through the preparation time.
(See section 'Settings'). To shake the ingredients, pull the frying basket out of the appliance by the handle and shake it. Then slide the frying basket back into the air fryer.

8. When you hear the timer, the set cooking time has come to an end. Pull the frying basket out of the air fryer and place it on a heat resistant surface. Only hold the frying basket by the handle and do not touch it directly for about 30 minutes after use as it can be very hot.

9. Check if the ingredients are ready.

If they are not ready, slide the frying basket back into the air fryer and cook them for an extra few minutes.

Do not turn the frying basket upside down with the grill plate still attached to it, as any excess oil that has collected on the bottom of the frying basket will spill out and leak onto the ingredients.

After hot air frying, the frying basket, grill plate and the ingredients are hot. Depending on the type of ingredients in the air fryer, steam may escape from the frying basket.

10. Empty the cooked food into a bowl or onto a plate.

Tip: *To remove large or fragile ingredients, use a pair of tongs (not included) to lift the ingredients out of the frying basket.*

11. When a batch of ingredients is ready, the air fryer is instantly ready for preparing another batch.

SETTINGS:

Manually setting a cooking time and temperature allows many different combinations. The following table details a range of cooking times and temperatures for a variety of foods.

Note: Keep in mind that these settings are only for reference. As ingredients differ in origin, size, shape as well as brand, we cannot guarantee the best setting for your ingredients.

	TIME (MIN)	TEMPERATURE (DEGREES CELSIUS)	SHAKE	EXTRA INFO	MIN-MAX AMOUNT (G)
POTATOES AND FRIES					
Thin frozen fries	12 - 16	200	Shake		300-700
Thick frozen fries	12 - 20	200	Shake		300-700
Home-made fries (8 x 8 mm)	18 – 25	180	Shake	Add ½ tbsp of oil	300-700
Home-made potato wedges	18 – 22	180	Shake	Add ½ tbsp of oil	300-700
Home-made potato cubes	12 - 18	200	Shake	Add ½ tbsp of oil	300-700
Rosti	15 – 18	180			250
Potato gratin	10 - 22	180			250
MEAT AND POULTRY					
Steak	8 – 12	180			100-500
Pork chops	10 – 14	180			100-500
Hamburger	7 – 14	180			100-500
Sausage roll	13 – 15	200			100-500
Drumsticks	18 – 22	180			100-500
Chicken breast	10 - 15	180			100-500
SNACKS					
Spring rolls	8 - 10	200	Turn	Use oven ready	100-400
Frozen chicken nuggets	6 – 10	200	Shake	Use oven ready	100-500
Frozen fish fingers	6 – 10	200		Use oven ready	100-500
Frozen bread crumbed cheese snacks	10	200		Use oven ready	100-500
Stuffed vegetables	10	160		Use oven ready	100-400

	TIME (MIN)	TEMPERATURE (DEGREES CELSIUS)	SHAKE	EXTRA INFO	MIN-MAX AMOUNT (G)
BAKING					
Cake	20-25	160		Use a baking tin or oven dish (not included)	300
Muffins	15-18	200			300

Note: Add 3 minutes to the preparation time before you start frying if the appliance is cold.

Tips:

- Smaller ingredients usually require a slightly shorter preparation time than larger ingredients.
- A larger amount of ingredients only requires a slightly longer preparation time; a smaller amount of ingredients only requires a slightly shorter preparation time.
- Shaking smaller ingredients halfway through the preparation time optimized the end result and can help prevent unevenly fried ingredients.
- You can coat fresh potatoes with a little oil for a crispy result. Fry your ingredients in the air fryer within a few minutes after you have added the oil.
- Do not prepare extremely greasy ingredients such as sausages in the air fryer.
- Snacks that can be prepared in an oven can also be prepared in the air fryer.
- The optimal amount for preparing crispy fries is 500 grams.
- Use pre-made dough to prepare filled snacks quickly and easily. Pre-made dough also requires a shorter preparation time than home-made dough.
- You can also use the air fryer to reheat ingredients by setting the temperature to 150°C and the timer to about 10 minutes.

MAKING HOME MADE FRIES:

For the best results, we advise to use pre-baked fries. If you want to make home-made fries, follow the steps below:

1. Peel the potatoes and cut them into sticks.
2. Soak the potato sticks in a bowl of water for at least 30 minutes, take them out and dry them with kitchen paper.
3. Pour 1/2 tablespoon of olive oil in a bowl, put the sticks on top and mix until the sticks are coated with oil.
4. Remove the sticks from the bowl with your fingers or a kitchen utensil so that excess oil stays behind in the bowl. Put the sticks in the frying basket.
Note: Do not tilt the bowl to put all the sticks in the frying basket in one go, to prevent excess oil from collecting at the bottom of the frying basket.
5. Fry the potato sticks according to the instructions in the settings page.

TROUBLESHOOTING:

Problem	Possible cause	Remedy
The appliance is not working.	The appliance has no power supply	Check the socket with another appliance.
		Plug in the mains plug correctly.
		Check the main circuit breaker.
	You have not set the cooking time.	Select a desired cooking time.
	The frying basket is not inserted correctly.	Check the correct position.
Frying pot can't slide back into the appliance	There is too much food in the frying basket.	Do not fill the frying basket beyond the Max level.
The food is not cooked to the end.	The frying basket is too full.	Reduce the amount of food. Smaller quantities are cooked evenly.
	The temperature is set too low.	Set the temperature higher with the temperature control buttons.
	The cooking time is set too low.	Set the time higher with the timer control buttons.
The food is cooked unevenly.	When foods are placed on top of each other, there is inadequate airflow.	The food must be shaken after half the cooking time.
The food is not crisp.	Foods are used, which is only suitable for a conventional fryer.	Use oven-ready food or sprinkle it with a little oil.
Homemade French fries are unevenly fried	You didn't rinse the potato properly before frying.	Rinse the potato sticks properly to remove starch from outside of them.
Homemade French fries are not crispy	The crispiness of the fries depends on the amount of oil and water in fries.	Make sure you dry the potato sticks before adding oil. Cut smaller sticks for a crispier result. Add slightly more oil for a crispier result.
Smoke comes out of the appliance.	You are preparing very fatty foods.	Fat splashes inside the unit may cause the emission of fumes. Provide adequate ventilation.
	There are still fat residues in the frying basket from previous use.	Clean the frying basket after each use.

CLEANING:

Clean the appliance after every use.

The frying basket, grill pan and the inside of the appliance have a non-stick coating.

Do not use metal kitchen utensils or abrasive cleaning materials to clean them, as this may damage the non-stick coating.

1. Remove the mains plug from the wall socket and let the appliance cool down.

Note: Remove the frying basket to let the air fryer cool down more quickly.

2. Wipe the outside of the appliance with a moist cloth.

3. Clean the frying basket and grill pan with hot water, some washing liquid soap and a non-abrasive sponge.

You can use a degreasing liquid to remove any remaining dirt.

Note: The frying basket and grill pan are dishwasher-proof.

Tip: If dirt is stuck to the grill pan, or at the bottom of the frying basket, fill the frying basket with hot water and with some washing liquid soap. Put the grill pan in the frying basket and let the frying basket and the grill pan for approximately 10 minutes.

1. Clean the inside of the appliance with hot water and a non-abrasive sponge.

2. Clean the heating element with a cleaning brush to remove any food residues.

STORING:

Allow the air fryer to cool completely before storing. Store the air fryer in a dry location. Do not place any heavy items on top of air fryer during storage as this may result in possible damage of air fryer.

LENOXX

www.lenoxx.com.au

 1300 666 848

 LenoxxElectronics

 LenoxxElectronics

 @LenoxxAustralia