

Healthy Choice

EFP120

LARGE ELECTRIC WOK

DIE-CAST ALUMINUM HOUSING



Model no: EFP120

Batch no: PR3693

**PLEASE READ AND RETAIN THESE
INSTRUCTIONS FOR FUTURE REFERENCE.**

Household use only.

Introduction:

Create authentic oriental inspired meals at home with the Healthy Choice Electric Wok. With a 4.5 litre capacity and 5 temperature settings to choose from, it is sure to cook up some family favourites at your place. With fast heating from it's unique 'butterfly' shaped element your wok is ready to cook quickly. A non-stick coating ensures that food won't stick to it's surface and less oil can be used when cooking. The glass lid with steam vent helps to retain heat when cooking foods at a slower pace such as casseroles or curries. Not just a wok– you can also use it to shallow fry and deep fry foods, or you can also steam veggies for a healthier option.

Features:

- Non-stick coating
- Adjustable temperature control
- 5 temperature settings
- Removable control unit for easy cleaning
- Glass lid with steam vent
- Cool touch handles and knobs
- 33cm (diameter) x 9cm (depth)
- 4.5 Litre capacity
- Wattage: 220 – 240V 1500W

Important safety instructions:

- Please read these operating instructions through carefully before using the wok.
- Only connect the unit to an AC power supply. The voltage listed on the rating plate must coincide with the voltage of your power supply.
- Do not use the unit with an extension lead or power board.
- Keep the electric cable away from hot surfaces and open flames or sharp edges.

- Avoid danger of tripping, do not allow the electric cable to hang down.
- Never touch the electric cable and plug with wet hands.
- Never immerse the unit, electric cable or plug into water or other liquids. Danger to life through electric shock!
- Never leave the unit unattended during use.
- Keep children away from the unit. Pay particular attention when children are in the vicinity!
- This appliance is not intended for use by person (including children) with reduced physical, sensory or mental capability has or lack of experience and knowledge, unless they have been given supervision or instruction concerning use of the appliance by a person responsible for their safety.
- Children should be supervised to ensure that they do not touch or play with the appliance.
- Do not use the unit outside.
- The unit is only intended for home use and not for commercial purposes.
- This appliance is only intended to be used in household and similar applications such as:
 - staff kitchen areas in shops, offices, and other work environments
 - farm houses
 - by clients in hotels, motels, bed and breakfast and other residential environments
- Do not use a sharp knife to cut food items on the surface of the wok.
- Only use plastic or wooden utensils when cooking to protect the non-stick surface of the wok from becoming scratched.
- Regular high heat cooking may discolour the non-stick surface, this is normal and will not affect the performance of the non-stick coating.

- Check the unit, electric cable and plug regularly for visible damage. Do not use the unit under any circumstances if you have noted any damage.
- Have damage repaired by a qualified specialist only. Never attempt to repair any damages yourself.
- Only use the unit on a steady, heat-resistance surface. Never position the unit close to hot surfaces or open flames.
- Do not use the unit on an unsteady surface or a flammable surface such as carpet or a table cloth.
- Ensure there is at least 15cm clearance space around the unit while it is in operation.
- Do not put the thermostat controller on the wok's surface.
- High temperatures are present during operation. Only touch the handles on the unit.
- Do not move the wok during operation.
- The wok is not designed to be operated with an external timer or a separate remote control system.

Packaging information:

■ **Warning of suffocation!** Keep children and animals away from the packaging material!

- The unit is packaged to protect against transport damage.
- The packaging materials are recyclable. Please dispose of the packaging materials via the appropriate recycling system in an environmentally-friendly manner.

Unit overview:

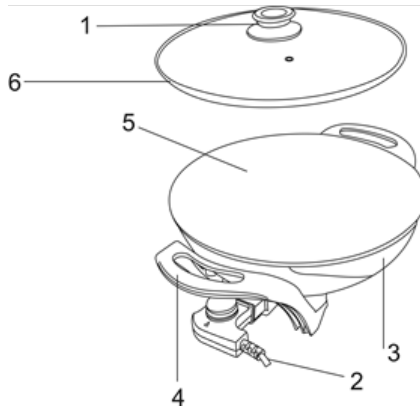

1. Glass cover handle
2. Power connection base
3. Wok
4. Handles
5. Cooking surface
6. Glass cover

Temperature sensor:

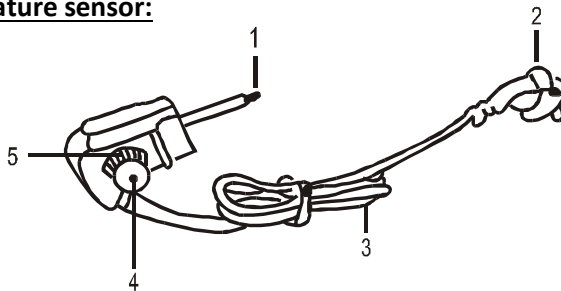

1. Temperature sensor
2. Electric plug
3. Electric cable
4. Temperature regulator
5. Control lamp

Preparing the unit:

Note:

- Before using the unit for the first time, carefully clean the unit and lid.
- Do not use any aggressive detergents, brushes with metal or nylon bristles or sharp objects such as knives or spatulas for cleaning the unit.
- Avoid damaging the non-stick coating.
- Always dry the unit thoroughly after cleaning it.

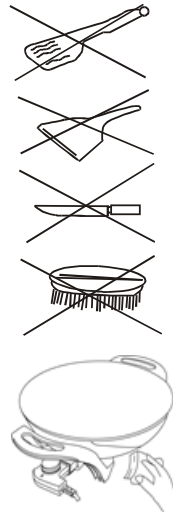

Connecting the unit:

1. Connect the temperature regulator to the base of the wok.
- Make sure that the plug is connected properly.
2. Set the temperature selector switch to heat level "0".
3. Connect the plug to a 220-240 V / 50/60 Hz power point.



ATTENTION:

Do not use a power board or an extension lead.

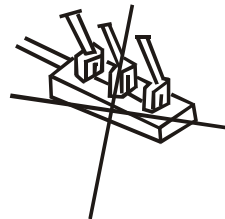

Preparing foods:

1. Brush the wok with a little cooking oil.
2. Set the temperature regulator to the required heat level.
The control lamp will light up to signal that the unit is ready for use (ON).



Heating levels	Temperature C°	Food type
1 & 2	100 C°	Roasted food, Simmering (eg: sauces)
3 & 4	150- 200 C°	Pancakes, scrambled eggs, bacon, braising, stewing (eg: curry, casseroles) rice, pasta, steaming foods (eg: vegetables)
5	240 C°	Stir frying, grilled foods, pizza, shallow frying
Thermostat		Warming function

- It takes 5-10 minutes after the unit is switched on before the control light will be on. You can then start cooking the food.
- Once cooking is complete, the unit can be kept warm. To do this, set the temperature regulator to the thermostat level.

- The control light may come on and off during your cooking process. This is not an error. The temperature regulator is automatically functioning and regulating the temperature.

Cooking tips:

Sir-fry:

- It is recommended to stir fry meat on the highest heat setting.
- The cooking method for stir-frying is to toss food continuously to expose all the ingredients to heat to ensure a quick and even cooking result.
- Do not over fill the wok, cook in smaller batches and re-heat food together at the end of stir-frying the batches. If using this method, under cook your food slightly so that when re-heating the finished meal is not tough.
- Stir-fry vegetables before meat in a little oil or sprinkling of water briefly so they retain crispness and remain vivid in colour.
- Stir-frying is best suited to tender cuts of meat as it uses a dry heat cooking method.
- Cooking times are dependent on the thickness and size of the cuts of meat.
- Thicker and larger pieces of meat will need more cooking time.
- Thin meat strips between 5 – 8 cm are recommended for stir-frying.
- Toss the stir-fry meat in a small amount of oil before cooking
- Meat should be stir-fried on small batches (up to 300g). This avoids the meat stewing in it's own juices and becoming tough. Cooking in small batches also helps the heat in the wok remain at a constant level to ensure the meat does not become tough from stewing in it's own juices.
- Stir-fry meat for between 1 – 2 minutes.
- Remove a cooked batch of meat and then wait for the wok to re-heat before stir-frying the next batch of meat.

- If you are cooking meat strips which have been marinated, drain off the marina before stir-frying to prevent meat from stewing.
- Serve your stir -fry quickly after cooking for a crisp, hot and tasty meal.

The Healthy Choice electric wok is not just for stir-frying, it can also be used to prepare curries and casseroles (stewing) when using a lower heat setting. You can steam in the wok by using a steaming rack (not included).

Stewing:

- When used on a low heat, the wok is ideal to make hearty stews and casseroles as well as curries.
- Keep the lid on when stewing and remove the lid to stir your ingredients.

Steaming:

- If using a metal rack, take care not to scratch the surface of the wok. Ideally, use a silicone steamer basket or insert.
- Check the liquid level at regular intervals and add more hot water if further steaming is required.
- Do not allow the liquid inside the wok to touch the steaming rack or food.
 1. Add 2 cups of water or liquid stock to the wok.
 2. Pace your steaming rack into the wok.
 3. Pre-heat the wok on temperature level 3 - 4 until the liquid is simmering.
 4. Place the food to be steamed into the steaming rack.
 5. Place the lid on the wok and simmer until the food is cooked as desired.
- When removing the lid, take care to lift it off away from you.

Shallow frying:

- When used on heat level 4 – 5, use approx. 1 – 1.5 cups of oil to shallow fry crispy cooked foods – such as chicken strips, mini spring rolls or dim sims, homemade chips etc.
- Cook food until golden in colour and flip food (turn over) to ensure it is cooked evenly.
- Do not cover the wok with the lid when shallow frying.

Deep frying:

- When used on heat level 4 – 5, fry your food in batches to prevent the oil temperature from decreasing and preventing food from becoming soggy.
- Food suitable for deep frying should be coated with breadcrumbs or batter.
- Before adding the food, pre-heat the oil to the desired temperature.
- Do not cover the wok with the lid when deep frying.

Using the lid:

- Use the glass lid where possible when cooking all food types.
- The lid prevents smells from escaping and reduces cooking time.

Note:

- The glass lid has a vent through which hot steam can escape.
- Avoid contact with this escaping steam.
- The lid can become extremely hot during operation therefore use oven gloves, etc. where possible when removing the lid to avoid burns.
- When removing the lid, take care to lift it off away from you.

After use:

- Set the temperature regulator to the 0 level and pull the plug out of the mains power point.
- Allow the unit to cool down thoroughly before cleaning it.

Cleaning:

- Clean the wok after use with a damp soft cloth or damp paper towel.
- If there is difficult to remove residue on the wok, put a little water in the wok and turn it on. The wok will be heated, and the residue can be rubbed away.
- Do not use any aggressive detergents, thinners, brushes with metal or nylon bristles or sharp objects such as knives or spatulas when cleaning the unit.
- To clean the thermostat controller, wipe it with a dry soft cloth or paper towel.
- To clean the lid, wipe it with a damp soft cloth or damp paper towel with a little detergent. Rinse it and dry it thoroughly after use.
- Do not put the wok or thermostat controller into water.
- Always dry the unit thoroughly after cleaning it and before storing it away.
- None of the parts for the wok are dishwasher safe.

To clean stubborn stains:

- Add ½ cup of lemon juice and 2 cups of water to the wok.
- Put the lid on the wok. Then, turn the wok on to heating level 2.
- Allow the liquid to heat up and simmer for 10 minutes.
- Then turn the wok off and disconnect it from mains power.
- Tip the liquid out and wash the wok in warm soapy water with a damp soft cloth.
- Do not submerge the wok into water.

Discolouration:

Regular high heat cooking may discolour the non-stick surface, this is normal and will not affect the performance of the non-stick coating.

Troubleshooting:

PROBLEM	POSSIBLE CAUSE/SOLUTION
The device does not work	<ul style="list-style-type: none">• Is the device plug inserted correctly in the connecting socket for the device plug?• Is the mains plug inserted in the plug socket correctly?• Is the plug socket defective? Try another one.• Check the fuse of the mains connection.
Development of odours or smoke	<ul style="list-style-type: none">• When the device is first used: Any coating residues that may remain may result in a small amount of odour or smoke development. This is normal. Allow the device to heat up for approx. 15 minutes.• The device has already been used: Is the wok pan dirty? Clean the wok pan.

LENOXX

www.lenoxx.com.au

 1300 666 848

 LenoxxElectronics

 LenoxxElectronics

 @LenoxxAustralia

Recipes to get you started:

Chicken and capsicum stir-fry with oyster sauce

Ingredients:

- 500g chicken breast strips
- 3 tablespoons oyster sauce
- 2 tablespoons sherry cooking wine
- ¼ teaspoon ground black pepper
- ¼ teaspoon salt
- ½ cup chicken stock
- ½ teaspoon cornstarch
- 1 ½ cups red capsicum, chopped and deseeded
- 3 tablespoons cooking oil

Method:

1. Combine oyster sauce, sherry cooking wine, ground black pepper, and salt in a bowl. Mix well.
2. Add the thinly sliced chicken. Marinate for 10 minutes.
3. Heat 1 tablespoon cooking oil in the wok.
4. Once the oil becomes hot, stir-fry the capsicum for 1 minute. Remove from the wok and set aside.
5. Pour the remaining cooking oil on the wok. Once the oil gets hot, put the marinated chicken in the pan. Dis-regard the remaining marinade. Stir fry for 2 minutes or until the chicken turns light to medium brown.
6. Add the cooked capsicum. Continue to stir-fry for a another 30 seconds – 1 minute.
7. Combine the chicken stock and cornstarch. Mix well and then pour into the wok.
8. Stir-fry until the texture of the sauce thickens.
9. Transfer to a serving plate. Serve with rice or noodles.

Chicken and cashew stir-fry

Ingredients:

- 500g chicken breast strips
- 1 raw egg, beaten
- 1 cup cornstarch
- 1 red onion, sliced
- ½ cup red capsicum, cut into strips and deseeded
- 1½ cups broccoli, cut into bite sized pieces
- 2 tablespoon soy sauce
- 2 tablespoon cooking rice wine
- 1 tablespoon oyster sauce
- ½ cup cashew nuts, roasted
- ½ cup spring onion, chopped
- ¼ cup cooking oil

Method:

1. Beat the egg and pour-over the chicken strips then mix well until properly distributed.
2. Heat the wok and add the cooking oil
3. Dip the chicken strips (coated with egg) in corn starch and stir fry until the color of the chicken turns golden brown. Set aside.
4. In wok, add some cooking oil and allow to heat-up.
5. Stir-fry the onion, capsicum, and broccoli.
6. Add the cooking rice wine, soy sauce, and oyster sauce then allow to cook for a few minutes.
7. Add the stir-fried chicken and cook for 2 minutes while mixing with the rest of the ingredients.
8. Add the cashew nuts, spring onion, salt, and ground black pepper.
9. Transfer to a serving plate. Serve with rice or noodles.

Beef curry

Ingredients:

- 500g beef strips
- 1 red onion, sliced
- 1 tablespoon cooking oil
- 1 red capsicum, chopped and deseeded
- 1 tbsp madras curry powder
- 2 level tbsp tomato puree
- ½ a butternut pumpkin, peeled and chopped into bite sized pieces
- 250g mushrooms, halved
- 275ml beef stock
- 150g natural yogurt
- Chopped fresh coriander, to serve

Method:

1. Heat the wok and add the cooking oil.
2. Add the onion and stir-fry until partially cooked.
3. Add the beef strips to the wok with the capsicum and stir-fry for 2 minutes.
4. Add the curry powder and tomato puree and mix well.
5. Add the pumpkin and mushrooms to the wok and mix well.
6. Pour in the stock and mix well.
7. Add the lid to the wok, reduce the heat level to 3.
8. Cook for 25 minutes. Mix well occasionally.
9. Transfer to a serving plate
10. Serve the curry drizzled with yogurt and scattered with coriander, with rice on the side.

Old fashioned beef stew

Ingredients:

- 1.5 kg diced beef pieces
- 3 tablespoon cooking oil
- 2 teaspoon salt
- 1 tablespoon freshly ground pepper
- 2 red onions, chopped
- 1/4 cup flour
- 3 garlic cloves, minced
- 1 cup red wine
- 3 cups beef stock
- 1/2 tsp dried rosemary
- 1 bay leaf
- 4 carrots, peeled, cut into 2.5cm slices
- 2 stalks celery, cut into 2.5cm slices
- 3 large potatoes, peeled, cut in eights

Method:

1. Heat the wok and add the cooking oil. Add the diced beef pieces and stir-fry until they are browned.
2. Add the salt and pepper while browning the beef. Mix well.
3. Reduce the heat level to 3 and add the flour while cooking and mixing for 2 minutes.
4. Add the garlic and mix well. Add the wine and mix well.
5. Allow the contents to simmer for 5 minutes and mix well constantly. The mixture will begin to thicken.
6. Then add the bay leaves, rosemary and beef stock. Mix well.
7. Reduce the heat level to 1. Put the lid on the wok and cook for 45 minutes, mix well every 10 minutes.
8. Remove the lid carefully and add the potatoes, carrots and celery and mix well.
9. Simmer covered for 30 minutes or until the beef and vegetables are tender.
10. Turn off the heat and allow the stew to sit before serving. Mix well and serve with mashed potatoes.

Beef black bean

Ingredients

- 500g beef strips
- 1 tablespoon grated ginger
- 2 cloves garlic, crushed
- 2 red onions, finely sliced
- 2 red capsicums, deseeded, sliced
- 300g snow peas, trimmed
- 125g baby corn, halved
- 1 handful of green beans, cut into 4cm lengths
- 1/2 cup reduced-salt chicken stock
- 2 tablespoons tinned black beans
- 2 tablespoons reduced-salt soy sauce
- 4 teaspoons cooking oil

Method

1. Combine beef, ginger, garlic and onion in a bowl and marinate for 5 minutes.
2. Heat the wok and add 2 teaspoons of cooking oil.
3. Stir-fry the capsicum, snow peas, corn and green beans until just tender. Then, remove from the wok and keep aside.
4. Combine stock, black beans and soy sauce in a small bowl.
5. Add the remaining cooking oil to the wok.
6. Add the beef mixture.
7. Stir-fry for 2 – 3 minutes.
8. Add the black bean mixture and vegetables to the wok.
9. Toss to combine and heat.
10. Transfer to a serving plate. Serve with rice or noodles.

Thai pork mince

Ingredients

- 1 tbsp oil
- 1 x 500g pork mince
- 1 red pepper, deseeded and sliced
- 250g chestnut mushrooms, quartered
- 2 tablespoons from a jar of Thai base paste
- 2 tablespoons corn flour
- 300ml chicken stock
- 1 tablespoon Thai fish sauce
- 400g pack beansprouts, rinsed
- juice of 1 lime
- 2 tablespoons chopped coriander leaves

Method

1. Heat the oil in the wok.
2. Add the pork mince and stir-fry until cooked. Ensure it is broken up and not in clumps.
3. Add the red pepper, mushrooms and Thai base paste and stir fry for a further 2 minutes
4. Mix in the corn flour and stir.
5. Add the chicken stock and Thai fish sauce.
6. Lower the heat and simmer uncovered for 10 minutes.
7. Add the bean sprouts to a serving plate.
8. Stir the lime juice into the pork mince.
9. Add the pork mince to the bean sprouts on the serving plate.
10. Serve with rice or an Asian salad.
11. Stir the lime juice into the pork mince.

Sweet and sour pork

Ingredients

- Sunflower or canola oil for deep frying
- 450g pork fillet – cut into 2.5 cm cubes
- 1 tablespoon sake
- 3 tablespoons plain flour, sifted
- 1 medium egg, lightly beaten
- 2 red capsicums, deseeded and cut into 2.5 cm pieces
- 1 bunch of spring onion, trimmed and cut into 2.5 cm pieces
- 225g can bamboo shoots, rinsed and drained
- 1 x 440g can unsweetened pineapple chunks in juice – drained but keeping the juice aside.
- 1 tablespoon corn flour
- 1 tablespoon soy sauce

Sweet and Sour Sauce:

- 2 tablespoons corn flour
- 100ml water
- 4 tablespoons soft brown sugar
- 2 tablespoons soy sauce
- 6 tablespoons rice wine vinegar or white wine vinegar
- 2 tablespoons tomato ketchup

Method

1. Place cubed pork into a bowl. Add sake and soy sauce and mix well. Set aside.
2. Make the batter for the pork. Sift the flour into a medium sized bowl. Make a well. Drop the beaten egg into the well and beat until the mixture is smooth. Set aside.
3. Make the sweet and sour sauce. Place the corn flour into a small saucepan. Mix in the water, sugar, soy sauce, vinegar and ketchup over a low heat. Simmer gently until the mixture has thickened, stir it constantly for 2 – 3 minutes.
4. Remove the cubed pork from the marinade and place it onto a plate.

5. Dust 1 tablespoon of corn flour over the pork and then mix it into the batter.
6. Heat the sunflower or canola oil in the wok on high heat.
7. When the oil is very hot, deep fry the batter coated pork in small batches. Each batch should take 2 – 3 minutes.
8. Once each batch is a deep golden colour, remove it from the oil in the wok and drain it on some paper towel.
9. Then add all the cooked pork back to the wok and deep fry for an additional minute.
10. Remove the cooked pork from the oil and set it aside.
11. Drain the used cooking oil from the wok.
12. Heat another two tablespoons of sunflower or canola oil in the wok. When the oil is sizzling hot, add the capsicum, spring onions and stir-fry for a minute.
13. Add the bamboo shoots and pineapple chunks to the wok. Mix the wok contents.
14. Add the sauce and mix well.
15. Add a little of the pineapple juice to the mix if you want a more saucy mixture.
16. When the sauce mix is bubbling, add the cooked pork and mix well so that the pork is coated with sauce.
17. As soon as the pork is coated with sauce, remove it from the wok.
18. Transfer to a serving plate. Serve with rice or noodles.

Doughnut balls

Ingredients

- 500g plain flour
- 1 teaspoon baking powder
- 70g butter
- 70g caster sugar or cinnamon sugar
- 1 Egg
- Pinch of nutmeg
- 250 ml milk
- Vegetable oil for frying

Method

1. Sift the flour, baking powder and nutmeg into a bowl.
2. Use your fingers to rub the butter into the flour, the flour and butter should be crumbly.
3. Mix in the sugar.
4. Beat the egg and milk together in a separate bowl.
5. Make a well in the flour mixture, then pour in the egg and milk mixture.
6. Mix all together to form a soft dough.
7. Roll the dough out onto a well-floured surface.
8. Roll the dough into 2cm lengths and use a knife to cut the lengths into 2 cm pieces.
9. Add the oil to the wok and heat it on the highest setting.
10. When the oil is sizzling hot, add the doughnut pieces. Cook a few at a time.
11. Fry for about 30 seconds and then turn over and fry for another 30 seconds or until golden brown.
12. Drain on some paper towel.
13. Roll the doughnut balls in the sugar or cinnamon sugar.