MASTERPRO

PREMIUM QUALITY

DELUXE MULTI CONTACT GRILL WITH TEMPERATURE PROBE

INSTRUCTION MANUAL

F5100250

Thank you for choosing the MasterPro Deluxe Multi Contact Grill with Temperature Probe. To ensure proper operation and to maintain the lifespan of your appliance, please read these instructions carefully before use.

IMPORTANT SAFETY INSTRUCTIONS

Read all the instructions before operating the appliance and retain for future use.

- This appliance is intended for indoor use only.
- This appliance is not intended for use by persons (including children) with reduced physical, sensory, or mental capabilities, or lack of experience and knowledge, unless they have been given supervision or instruction concerning use of the appliance by a person responsible for their safety.
- Children should not use this appliance unsupervised. Do not let the cord hang down where children can grab and pull.
- Children should not be allowed to play with the appliance.
- The supply cord should be regularly examined for signs of damage. If cord is damaged, it must be replaced by qualified persons to avoid hazards.
- Do not operate any appliance with a damaged cord or plug, or after the appliance malfunctions, is dropped, or has been damaged in any manner.
- The appliance should always be used on a hard and stable surface, such as a table or benchtop.
- Do not operate this appliance using an extension cord.
- To protect against fire, electric shock, or personal injury, do not immerse the cord, plug, or unit in water or other liquids.
- To reduce risk of electric shock, never operate this appliance with wet hands or spill liquid on the appliance.

- Ensure the voltage indicated on the rating plate matches your domestic power supply.
- Do not place appliance or cord on hot surfaces such as stoves, hotplates or near open gas flames.
- This appliance is intended to be used in households and similar applications such as:
 - Staff kitchen areas in shops, offices, and other working environments
 - Farmhouses
 - Bed and breakfast type environments
- Only use parts, attachments and accessories provided with this product.
- Switch off appliance and disconnect from supply when not in use and before changing accessories, fitting, approaching moving parts, and cleaning.
- Disconnect the appliance from the power outlet by grasping the plug. Do not pull on the cord.
- Do not touch the hot surface of the grill during or after operation.
- Do not place any items on top of the grill, cover or block the vents while in operation.
- Never leave appliance unattended.
- This appliance is not intended to be operated by means of an external timer or separate remote-control system.

PACKAGING AND RECYCLING

The materials used for this product's packaging can be reused, recycled and disposed of through specific waste streams.

- **REUSE:** Keep packaging to safely store or transport your appliance, preventing damage.
- **RECYCLE:** Look for recycling symbols on packaging components to identify if they are recyclable. Check with your local authority to find out what materials are accepted for recycling in your area.
- **DISPOSE:** Look for symbols on packaging components and dispose of materials accordingly.

TECHNICAL INFORMATION

| | | | |
|---|---|--------------------------|--------------------------------------|
| Power supply | 220-240V ~ 50-60Hz | Input power | 2000W |
| Function | Default time and Temperature Display | Temperature Range | Time Range |
| Dual Grill (Temperature probe inserted) | 52C Probe Rare / 230°C | 150-230°C | Probe Temperature Doneness |
| Dual Grill (Without temperature probe) | 05:00 / 230°C | 80-230°C | 30 sec-60 min (30sec per adjustment) |
| Upper Grill | 10:00 / 200°C | 80-220°C | 30 sec-60 min (30sec per adjustment) |
| Lower Grill | 10:00 / 200°C | 80-220°C | 30 sec-60 min (30sec per adjustment) |

PRODUCT OVERVIEW

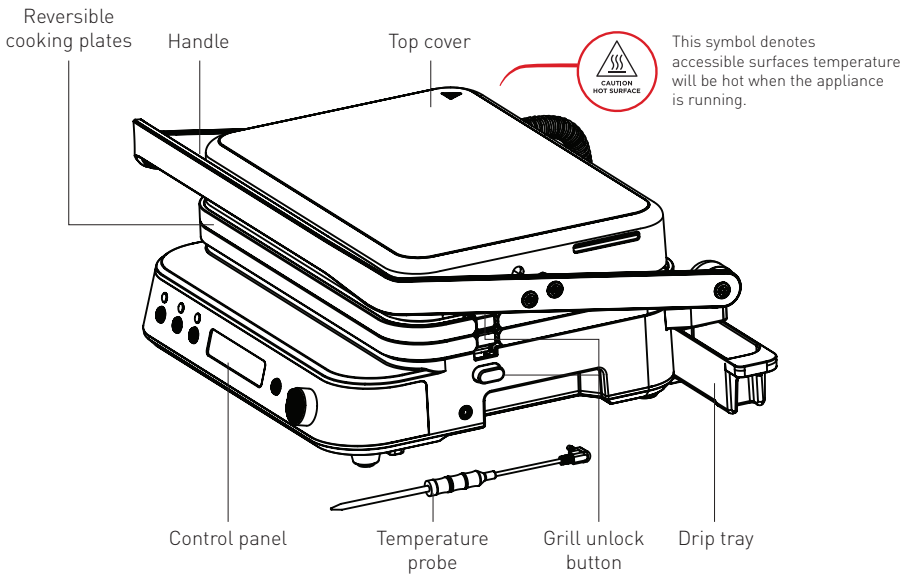

CONTROL PANEL OVERVIEW

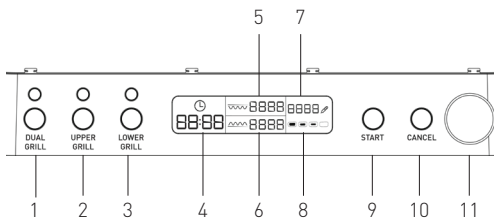

1. Dual Grill button (heats both cooking plates together)
2. Upper Grill button (heats upper cooking plate only)
3. Lower Grill button (heats lower cooking plate only)
4. Time display
5. Upper plate temperature display
6. Lower plate temperature display
7. Probe temperature display
8. Doneness display
9. Start button
10. Cancel button
11. Time and temperature dial

BEFORE FIRST USE

1. Take the appliance out of the package and remove all the packaging material. Check the appliance to ensure all necessary parts are present.
2. Press the unlock button and remove the cooking plates. (See Fig.1) You may use the unlock button to reverse the plates and switch between grill and flat griddle modes. If you wish to switch modes, reverse the plates before preheating or after grill has completely cooled down.
3. Clean cooking plates before first use. Cooking plates are dishwasher safe, or can be washed by hand with warm soapy water. Dry thoroughly with a clean cloth.
4. Fix the cooking plates back into position, making sure they are securely locked into place.
5. Slide the drip tray at the back of the appliance and make sure it is fixed in place. (See Fig.2)
6. If using the temperature probe, ensure it is correctly fixed in its slot at the side. (See Fig.3)

Fig.1

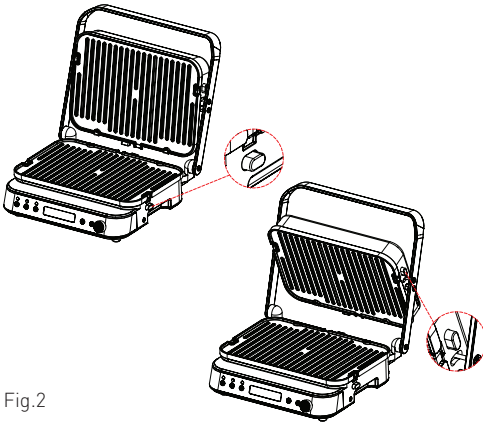

Fig.2

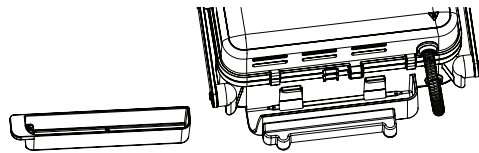
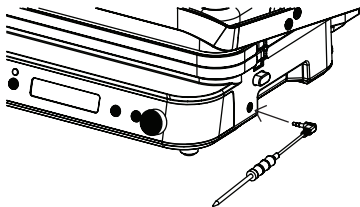

Fig.3



COOKING POSITIONS

The cooking position of the top cover can be adjusted by simply pulling the handle and adjusting the top cover to desired height and angle.

Contact grill (closed mode)



This is the default position of the contact grill with the upper plate resting over the lower plate. The cover automatically adjusts to the thickness of the food and cooks it quickly and evenly on both sides. This mode is ideal for cooking hamburgers, deboned meat and thin meat slices, vegetables and sandwiches. To cook multiple types of food at once in closed grill mode, ensure they are of similar thickness so the cover closes correctly.

Open grill

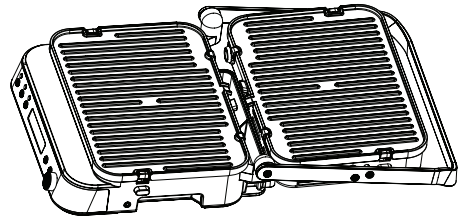

To use this position, adjust the upper plate to be level with the lower plate, doubling the cooking surface. The appliance can now be used as a grill/barbecue to prepare hamburgers, steak, chicken and fish, or create a breakfast platter of pancakes, eggs, cheese, fritters, bacon and sausages. The additional cooking surface enables you to cook more food without mixing flavours, or grill more cuts of meat of varying thicknesses. Make sure to turn the food while cooking.

Oven grill



To use this position, adjust the upper plate height so it hovers over the lower plate without contact. The oven grill is suitable for grilling thicker foods that need to be roasted slowly and uniformly, or soft sandwiches which cannot be pressed. The radiating upper plate enables water content to evaporate faster when grilling vegetables or other moist foods.

MANUAL OPERATION

1. Before switching on the appliance, choose the cooking plate mode you would like to use by using the unlock button to switch the reversible cooking plates to either grill or flat griddle mode. We also recommend adjusting the cooking position of the top cover to suit your desired cooking mode before preheating. The top cover will become hot as the cooking plates heat and will need to be adjusted with care using heat proof oven mitt.
Note: Make sure to switch modes either before preheating or after the cooking plates have completely cooled down.
2. The control panel interface will light up with all display screen indicators briefly, followed by displaying OFF before deactivating.
3. Select the desired cooking function by pressing the corresponding button.
 - Dual Grill (activates both cooking plates to the same set temperature)
 - Upper Grill (activates only upper cooking plate to set temperature)
 - Lower Grill (activates only lower cooking plate to set temperature)**Note:** Top and bottom cooking plates cannot be set to separate temperatures. They will run at the same set temperature.
4. The display screen will flash with the default time. Turn the time and temperature dial to adjust the time in increments of 30 seconds and press dial to set.
5. The display screen will flash with the default temperature. Turn the time and temperature dial to adjust the temperature in increments of 5°C and press dial to set.
Note: If temperature probe is connected and dual grill is selected to select the doneness, the probe function will flash after pressing dial in to set the temperature. Refer to next section for operating the grill with the temperature probe.

6. Press Start button to start preheating. As the unit begins to warm up, the control panel displays PRE indicating it is preheating.
7. After the preheating is completed, the appliance will beep 3 times. PRE will flash on the display screen to indicate preheating is over and the plate/plates have reached their desired temperature.
8. Add your ingredients to the cooking plate and press the Start button again.
9. The time display will begin to count down from your specified time.
Note: If the Start button is not pressed within 30 minutes, the unit will go into standby mode and display OFF.
10. When cooking is finished, the appliance will beep 5 times and the screen will display DONE.
11. Press the Cancel button to enter standby mode. The screen will display OFF.
12. Lift the top cover with the handle, taking care not to touch the top cover as it will be hot, and remove the food with care. Do not use sharp-edged metal tongs or knives as these may damage the non-stick coating of the cooking plates.

TEMPERATURE PROBE OPERATION

The temperature probe is ideal for controlling internal temperature when you require food such as steak to be cooked at a certain doneness. You can either insert the probe any time during cooking to check the temperature or leave it in the food while cooking to set the target temperature with the following steps.

1. Switch on the appliance and prepare the cooking plates as in the previous section and connect the temperature probe in its proper slot.
2. Select desired setting on reversible cooking plates and adjust to desired cooking position before setting temperature on appliance.
Note: Dual Grill mode must be selected for use with the temperature probe. Upper grill and Lower grill settings are not suitable for this cooking method and therefore cannot be selected for use with the temperature probe.
3. Turn the time and temperature dial to adjust the temperature and press the dial in to set.
Note: Time is not adjustable when using the temperature probe as different cuts of meat will take different amounts of time to cook as desired.
4. Turn the time and temperature dial again to select the desired time to cook to desired doneness; Rare, Medium, Medium Rare, Well Done.
5. Once the desired doneness has been selected, the display screen will show the temperature of the probe.
6. Press Start button to start preheating. As the unit begins to warm up, the control panel displays PRE indicating it is preheating.

7. After the preheating is completed, the appliance will beep 3 times. PRE will flash on the display screen to indicate preheating is over and the plate/plates have reached their desired temperature.
8. Add your ingredients to the cooking plate and insert the probe into the meat, then press the Start button again.

Note: To get the most accurate reading, probe tip must be inserted into the centre of the thickest part of the meat.
9. Once the food has reached the temperature corresponding to the selected doneness, the grill will turn off automatically and the screen will display DONE.
10. Press the Cancel button to enter standby mode. The screen will display OFF.
11. Lift the top cover using the handle and remove the food with care. Do not use sharp-edged metal tongs or knives as these may damage the non-stick coating of the cooking plates.

Note: If the probe is connected and the desired level of doneness is selected, removing the probe during the cooking process will cause the appliance to enter standby mode, with OFF displayed on the screen.

FLAT GRILL OPERATION

1. Allow cooking plates to heat up while appliance is closed; this will allow it to preheat quicker.
2. When preheating finishes, use the handle to lift and open the top cover (See Fig. 4).
3. Using a protective mitt, press the top cover back to align with the handle (See Fig. 5), then press both the handle and top cover to a flat position (See Fig. 6). Please exercise caution when opening the top cover as it will be hot after preheating.

Fig.4

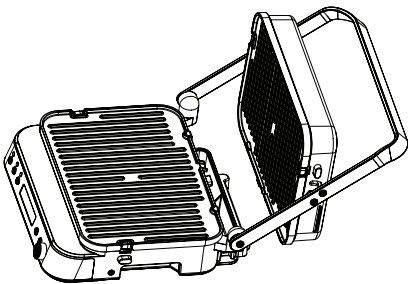

Fig.5

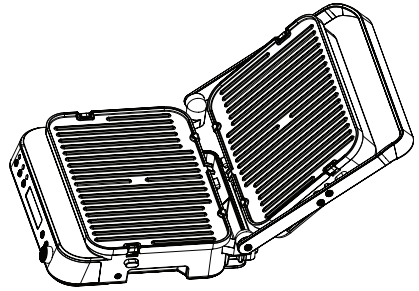
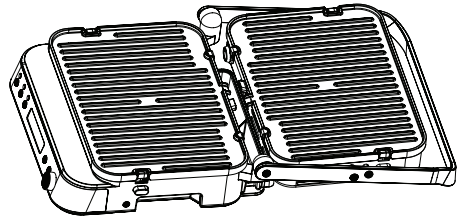

Fig 6.







TIPS

- While cooking, press the Cancel button to exit the current mode and choose your preferred function.
- While cooking, rotate the dial to adjust the time or temperature; to switch between time and temperature, press the dial down. The unit will begin cooking at the newly set time or temperature within 3 seconds.
- The appliance can recall the temperature and time settings from the previous cook. When the grill is switched on and the desired cook selected, the display will show the temperature and time from the last use.
- For optimal results, apply a small amount of cooking oil or cooking spray to the cooking plates.
- To shorten preheating time, keep the cooking plates closed during preheating.
- Use only the handle to open or close the top cover.
- If you need to adjust the angle of the top cover to utilise the open grill function, use a protective mitt as the top cover will be very hot.

STEAK GRILLING TIPS FOR TEMPERATURE PROBE

Below table describes ideal temperatures for grilling steak.

| Cook Type | Colour Description | Ideal Temperature | Recommended Temperature Range for Doneness | Icon |
|-------------|----------------------|-------------------|--|---|
| Custom | N/A | 45-95°C | N/A | No icon on display, only temperature displayed. |
| Rare | Cool red centre | 52°C | 49-54°C |  |
| Medium | Warm pink centre | 63°C | 57-63°C |  |
| Medium rare | Slightly pink centre | 66°C | 63-68°C |  |
| Well done | Little or no pink | 71°C | 68+°C |  |

HOW TO TEMP A STEAK

1. Push the temperature probe past where you think the centre of the steak is.



2. Pull the probe back until the temperature drops. It will keep dropping until it reaches the thermal centre.



Refer table below for internal probe temperature for various other types of meat.

| Meat | Temperature |
|----------------|-------------|
| Ribs (beef) | 93°C |
| Hamburger | 72°C |
| Lamb cutlet | 65°C |
| Pork chop | 72°C |
| Sausages | 80°C |
| Chicken breast | 75°C |
| Chicken wings | 80°C |
| Fish (whole) | 63°C |
| Salmon | 62°C |

All temperatures are approximate and based on an average sized portion of meat.

CLEANING

1. Disconnect the plug from the socket when the appliance is not in use and before cleaning the unit or its individual parts.

2. Allow the appliance to cool down completely.

Caution: The cooking plates will remain very hot and requires time to cool.

3. Press the unlock button to detach the cooking plate from the appliance.

4. After removing the cooking plate, clean it in warm soapy water or place it in the dishwasher.

Note: Avoid placing hot cooking plates directly into cold water. Doing so will cause thermal shock which reduces longevity of the non-stick coating and can warp the cooking plates.

5. Wear gloves to extract the drip tray from the back of the appliance. Empty drip tray into heat resistant receptacle to dispose of oil, and wash in warm soapy water, ensuring thorough drying.

Note: Before removing the drip tray, ensure the temperature of the oil or residue is below 40°C to prevent burns.

TROUBLESHOOTING

If the control panel displays any of the following error codes, follow the instructions as directed.

| Error Code | Fault Description | Solution |
|------------|---|-----------------------------|
| E1 | The upper plate temperature sensor has an open circuit. | Return product to retailer. |
| E2 | The upper plate temperature sensor has short-circuited. | |
| E3 | The lower plate temperature sensor has an open circuit. | |
| E4 | The lower plate temperature sensor has short-circuited. | |
| E5 | The temperature probe has short-circuited. | |

RECIPES

INGREDIENT COOKING GUIDE

| Meat Type | No. of Pieces | Cooking Level | Plate Mode | Temperature | Minimum Time | Tips |
|----------------|---------------|---------------|----------------------------|-------------|--------------|---|
| Beef | | | | | | |
| Steak | 2 | Rare | Contact grill (Dual grill) | 230°C | 4-5min | Apply small amount of cooking oil or spray. |
| Steak | 2 | Medium | Contact grill (Dual grill) | 230°C | 7-8min | Apply small amount of cooking oil or spray. |
| Steak | 2 | Well done | Contact grill (Dual grill) | 230°C | 13-15min | Apply small amount of cooking oil or spray. |
| Steak | 2 | Rare | Flat grill | 230°C | 5-6min | Apply small amount of cooking oil or spray. Turn steaks halfway through cooking. |
| Steak | 2 | Medium | Flat grill | 230°C | 7-8min | Apply small amount of cooking oil or spray. Turn steaks halfway through cooking. |
| Steak | 2 | Well done | Flat grill | 230°C | 14-16min | Apply small amount of cooking oil or spray. Turn steaks halfway through cooking. |
| Lamb | | | | | | |
| Cutlet | 2 | Medium | Contact grill (Dual grill) | 230°C | 10-12min | Apply small amount of cooking oil or spray. |
| Cutlet | 2 | Well done | Contact grill (Dual grill) | 230°C | 12-14min | Apply small amount of cooking oil or spray. |
| Cutlet | 2 | Medium | Flat grill | 230°C | 10-12min | Apply small amount of cooking oil or spray. Turn cutlets halfway through cooking. |
| Cutlet | 2 | Well done | Flat grill | 230°C | 12-14min | Apply small amount of cooking oil or spray. Turn cutlets halfway through cooking. |
| Chicken | | | | | | |
| Breast | 2 | - | Contact grill (Dual grill) | 230°C | 8-10min | Apply small amount of cooking oil or spray. |
| Wing | 8 | - | Flat grill | 200°C | 14-16min | Turn pieces once or twice while cooking. |
| Chicken kebab | 2 | - | Flat grill | 230°C | 11-13min | Turn pieces once or twice while cooking. |
| Pork | | | | | | |
| Chop | 2 | - | Contact grill (Dual grill) | 230°C | 9-11min | Apply small amount of cooking oil or spray. |
| Chop | 2 | - | Flat grill | 230°C | 11-13min | Apply small amount of cooking oil or spray. Turn chops halfway through cooking. |
| Spare rib | 6 | - | Flat grill | 200°C | 20-25min | Turn two or three times while cooking. |

| Meat Type | No. of Pieces | Cooking Level | Plate Mode | Temperature | Minimum Time | Tips |
|-----------|---------------|---------------|----------------------------|-------------|--------------|--|
| Bacon | 6 | - | Flat grill | 230°C | 2-3min | Turn two or three times while cooking. |
| Sausage | 4 | - | Contact grill (Dual grill) | 200°C | 12-14min | Pierce sausages with a fork and turn two or three times while cooking. |

| Food Type | No. of Pieces | Plate Mode | Temperature | Minimum Time | Tips |
|------------------------|---------------|----------------------------|-------------|--------------|---|
| Seafood | | | | | |
| Whole fish | 2 | Flat grill | 200°C | 8-10min | Apply small amount of cooking oil or spray. Turn once or twice while cooking. |
| Fish fillet | 2 | Flat grill | 200°C | 8-10min | Apply small amount of cooking oil or spray. Turn once or twice while cooking. |
| Fish slice | 2 | Flat grill | 200°C | 8-10min | Apply small amount of cooking oil or spray. Turn once or twice while cooking. |
| Squid | 6 | Flat grill | 200°C | 10-12min | Apply small amount of cooking oil or spray. Turn once or twice while cooking. |
| Prawns | 6 | Flat grill | 200°C | 4-6min | Apply small amount of cooking oil or spray. Turn once or twice while cooking. |
| Desserts | | | | | |
| Pancakes | 2 | Flat grill | 200°C | 4-5min | Butter cooking plates. Turn pancakes halfway through cooking. |
| Sliced pineapple | 2 | Contact grill (Dual grill) | 200°C | 5-6min | Butter cooking plates. |
| Vegetables | | | | | |
| Sliced eggplant | 2 | Contact grill (Dual grill) | 230°C | 4-6min | Apply small amount of cooking oil or spray. |
| Sliced zucchini | 2 | Contact grill (Dual grill) | 230°C | 6-8min | Apply small amount of cooking oil or spray. |
| Quartered sweet pepper | 2 | Contact grill (Dual grill) | 230°C | 8-10min | Apply small amount of cooking oil or spray. |
| Sliced tomato | 2 | Flat grill | 230°C | 5-7min | Apply small amount of cooking oil or spray. Turn halfway through cooking. |
| Sliced onion | 2 | Flat grill | 230°C | 5-7min | Apply small amount of cooking oil or spray. Mix often with a spatula. |
| Bread | | | | | |
| Bread roll | 2 | Contact grill (Dual grill) | 230°C | 2-3min | |
| Bread slices | 4 | Flat grill | 230°C | 4-5min | Turn halfway through toasting. |

HERB PESTO STUFFED GRILLED FLATBREAD

Serves 4

Cooking plate: Flat griddle

Ingredients

- 1 tsp dried instant yeast
- 1 tsp raw sugar
- $\frac{3}{4}$ cup warm water
- $1\frac{1}{2}$ cups strong white flour
- $\frac{1}{4}$ cup polenta
- $\frac{1}{2}$ tsp salt
- $1\frac{1}{2}$ tbsp olive oil, plus extra for greasing
- Extra flour for dusting
- 3 tbsp herb pesto (see end of recipe)
- Handful shredded mozzarella cheese
- 12 olives
- Handful fresh rosemary leaves
- Olive oil spray

Method

1. Place yeast, sugar, and water in a small bowl. Stir and set aside for 10 minutes until the mixture is frothy with bubbles.
2. Place flour, polenta, salt, and olive oil in a large bowl. Mix lightly with a fork. Make a well in the centre and pour in the yeast mixture.
3. Mix lightly with your hand and bring together to form a dough.
4. Using a mix of extra flour and olive oil, knead the dough for 5 minutes until it is smooth and elastic.
5. Cover with a tea towel and set aside to rise in a warm spot for 30 minutes.
6. Turn on your MasterPro Deluxe Multi Contact Grill, set for 230°C and allow to preheat.
7. Spray both surfaces with olive oil.
8. Stretch the dough into a rectangular shape.
9. Along the shorter edge, spread the pesto and sprinkle some cheese.
10. Fold the dough over and shape the dough into a rectangle roughly measuring 20cm x 15cm.
11. Press down the edges to seal.
12. Place on the flat grill surface. Scatter the top of the dough with fresh rosemary leaves.
13. Make 12 indents on the dough surface by pressing lightly with your finger.
14. Place an olive in each indent.
15. Drizzle some extra olive oil on top, pull the top of the grill down and grill covered for 10 minutes.
16. Open the top cover and using a wooden spatula, gently turn the bread back to front and grill for another 10 minutes until evenly cooked and browned. Serve hot.

To make the pesto: Into a food processor, add a large handful of fresh basil leaves, few sprigs of thyme, handful of pine nuts, one garlic clove, $\frac{1}{4}$ cup shredded parmesan, a pinch of salt and generous splashes of olive oil. Grind together to a coarse paste. Use this fresh pesto in your flatbread or for a variety of Mediterranean-inspired dishes.

FISH TACOS

Serves 4

Cooking plate: Grill

Ingredients

Fish marinade

- 600g barramundi (or any firm white fish) thawed
- Zest of 1 lime
- 3 tbsp lime juice
- 1 tbsp chipotle powder
- 1 tbsp pickled jalapeno, finely chopped
- $\frac{1}{4}$ cup coriander, finely chopped
- 2 garlic cloves, minced
- 3 tbsp olive oil
- Salt and pepper

Pickled cabbage

- 4 cups red cabbage, finely shredded
- 3 green onion stems, finely diagonally sliced
- 2 tbsp red wine vinegar (or white wine vinegar, or apple cider vinegar)
- $\frac{1}{2}$ tsp salt

Taco Sauce

- $\frac{3}{4}$ cup sour cream (or yoghurt)
- 2–3 tbsp sriracha, adjusted to taste

To cook and serve

- 1 tbsp olive oil
- 12 small tortillas (corn or flour), warmed
- Lime wedges
- Coriander

Method

To marinate the fish

- Combine the marinade ingredients and the fish in a food grade bag. Set aside for 20 minutes to marinate (no longer than 1 hour).

To prepare the pickled cabbage

- Place all the pickled cabbage ingredients in a bowl. Toss to combine and set aside for 30 minutes. Drain excess liquid and scrunch cabbage with your hands to help soften. Set aside.

To make the taco sauce

- Mix all ingredients to combine.

To cook the fish

1. Switch on your MasterPro Deluxe Multi Contact Grill.
2. Spray or rub on a small amount of olive oil.
3. Set the temperature on dual grills to 200°C, or if using probe until temperature is around 63°C.
4. Once grills have heated to desired temperature cook fish for 4 minutes on each side, or until golden and cooked.
5. Remove fish onto a plate then flake into large pieces.

To assemble tacos

- Top each tortilla with cabbage then fish, a dollop of sauce and a squeeze of lime juice. Fold tortilla over and enjoy!

GRILLED HALLOUMI SALAD

Serves 2–4

Cooking plate: Grill

Ingredients

- 225g halloumi cheese, sliced into ¼-inch slabs
- 2 tbsp olive oil, divided
- 3 small cucumbers, sliced into coins
- 1 punnet cherry tomatoes, halved
- 28oz (800g) baby greens mix
- 3 tbsp fresh mint, chopped
- 1 tbsp freshly squeezed lemon juice
- 1 tsp sea salt
- ½ tsp ground black pepper

Method

1. Switch on your MasterPro Deluxe Multi Contact Grill.
2. Set the temperature on dual grills to 230°C.
3. Brush each halloumi slice with 1 tablespoon of olive oil, coating both sides of the cheese.
4. Place the halloumi on the grill and close the top cover.
5. Cook for 2–4 minutes or until grill lines form and the cheese is melting.
6. While the halloumi is grilling, toss the sliced cucumbers, halved tomatoes, greens, and mint together. Spread them across a large, low bowl or large plate.
7. Mix the remaining olive oil, lemon juice, sea salt, and pepper together to create a dressing. Drizzle across the salad.
8. When the halloumi is done cooking, add it to the salad and serve immediately.

GRILLED BONE-IN PORK CHOPS WITH GARLIC BUTTER

Serves 2

Cooking plate: Grill

Ingredients

- 3 tsp salt
- ½ tsp freshly cracked black pepper
- 2 thick cut pork chops with bone, about 1½ inches thick (weighing about 255–283g)
- 2 tbsp butter
- 2 garlic cloves, thinly sliced
- Fresh parsley, minced

Method

1. Pat pork chops dry with paper towel.
2. Mix the salt and cracked black pepper and rub into each pork chop, seasoning both sides.
3. Lay pork chops on a wire rack inside a sheet pan and refrigerate for 2 to 24 hours.
4. When ready to cook, preheat your MasterPro Deluxe Multi Contact Grill to 230°C and place meat on the grill plate, closing the top cover to cook.
5. Allow to cook for 9–11 minutes, or if using probe until temperature is around 72°C.
6. Remove from heat and let rest for 5 minutes to let the juices distribute throughout.
7. While the pork chops are resting, put a cast iron skillet on the grill over medium heat.
8. Add butter and let melt, then add garlic and handful of minced parsley.
9. Let sauté for a few minutes until fragrant to create a garlic butter. (You can also do this while the pork chops are searing.)
10. Drizzle garlic butter over rested pork chops and enjoy!

GRILLED FRUIT SKEWERS WITH LEMON DIP

Serves 6

Cooking plate: Grill

Ingredients

- 1 cup plain Greek yoghurt
- 3 tbsp lemon curd
- 2 small bananas, cut into 2-inch chunks
- 1 mango, cut into 1-inch cubes
- 12 whole strawberries, trimmed
- ¼ fresh pineapple, cut into 1-inch cubes
- ½ small watermelon, cut into 1-inch cubes
- 1 small pound cake, cut into 1-inch cubes (optional)
- 2 tbsp honey
- 6 (10-inch) metal or wooden skewers
- 1 tsp melted coconut oil or vegetable oil

Method

1. In a small bowl, combine Greek yogurt and lemon curd. Set aside.
2. Thread fruit and cake, if using, onto skewers, alternating as desired.
3. Preheat your MasterPro Deluxe Multi Contact Grill to 230°C.
4. In a small microwave-safe bowl, warm honey in microwave for about 10 seconds. Brush honey over fruit.
5. Lightly brush oil on grill.
6. Grill skewers for 5-6 minutes, turning at halfway point, until fruit has grill marks all over.
7. Transfer to a platter and serve with lemon dip.

Tip: Soak the wooden skewers in cold water for 10 minutes to keep from burning.

SCRAMBLED EGGS & BACON

Serves 2

Cooking plate: 1 side flat griddle, 1 side grill

Ingredients

- ½ tbsp butter
- 4 large eggs
- 2 slices bacon
- Salt to taste

Method

1. Preheat your MasterPro Deluxe Multi Contact Grill to 230°C, closing the top cover until it reaches desired temperature.
2. Once temperature is reached carefully open the Contact Grill ensuring that both plates are firmly and evenly laid out in flat grill mode.
3. Add your bacon and grill to your desired crispiness on one plate. After 2–3 minutes turn over and allow to finish cooking while you scramble your eggs.
4. Crack eggs into a bowl, add a pinch of salt and whisk until well blended.
5. Add butter to the flat grill. When the butter begins to bubble, pour on the eggs, and immediately use a silicone spatula to swirl in small circles around the pan, without stopping, until the eggs look slightly thickened and very small curds begin to form. This takes about 30 seconds.
6. Change from making circles to making long sweeps across the pan until you see larger, creamy curds. This takes about 20 seconds.
7. When the eggs are softly set and slightly runny in places, remove the pan from the heat and leave for a few seconds to finish cooking. Give a final stir and serve immediately.
8. Remove the bacon from the grill as well.
9. Serve eggs with an extra sprinkle of salt, a grind of black pepper and a few fresh chopped herbs (if desired).

Tip: Scrambled eggs should be soft, creamy, and gently scrambled. Use low heat and monitor the eggs constantly to avoid them overcooking. Eggs are delicate and cook very quickly. It is recommended to turn off the grill before the scrambled eggs are finished cooking. Give the eggs a few seconds on the grill (with the heat off) and the eggs will turn out to be perfectly cooked — not dry, and not too wet.

OUR 12 MONTH GUARANTEE

In Australia, our goods come with guarantees that cannot be excluded under the Australian Consumer Law. You are entitled to a replacement or refund for a major failure and compensation for any other reasonably foreseeable loss or damage. You are also entitled to have the goods repaired if the goods fail to be of acceptable quality and the failure does not amount to a major failure.

We stand by this product. Therefore we offer a 12 month guarantee on the heating element. The benefits of this guarantee are in addition to any rights and remedies imposed by Australian Consumer Law. Our guarantee excludes normal wear and tear and instances where care and use instructions have not been followed.

What IsAlbi will do: During this guarantee period IsAlbi will repair, replace or refund any defective product. If identical product is not available for replacement, a similar product may be offered. IsAlbi asks you to cover the cost of postage/transit if the product needs to be sent back to us for inspection. If IsAlbi deems the product is defective, we will reimburse your postage/transit expenses. IsAlbi will be responsible for the postage/transit of the repaired/replacement product back to you.

What to do: If a fault/defect is identified cease using the product immediately. To make a claim on this guarantee, take the product, proof of purchase and full details of the alleged defect to the retailer from whom the product was purchased. If you cannot access the retailer or are unsatisfied with the solution offered by the retailer contact IsAlbi via the details below.

IsAlbi

87 Chifley Drive, Preston, Victoria 3072

P: +61 (03) 9474 1300

E: enquiries@isalbi.com.au

isalbi.com.au