

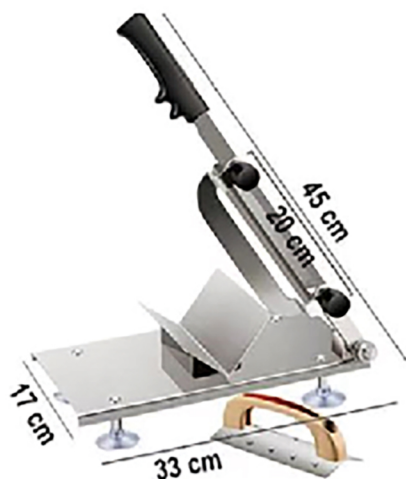

## CUSTOMIZED FOR HOME KITCHEN

MEAT CAN BE CUT THEN DEFROSTING ALL KINDS OF VEGETABLES MELONS AND FRUITS CAN BE SLICED EASILY



## PRODUCT DIAGRAM

### Operation precautions

Frozen meat temperature requirement: -2 degrees ~ 15 degrees (normal freezing storage about 12 hours)

Cut the meat into pieces and it will slip: if the meat is too hard, freeze it outdoors for 3-5 minutes (refer to the first point for freezing temperature) so that the cut meat will not curl and cannot be cut; if the meat is too soft, freeze it again (refer to the first point for freezing temperature)

Operation Note: Wipe the blade clean after each use, and then apply cooking oil for maintenance to keep it sharp; When adjusting the stainless steel frame, leave enough safety distance from the blade. When using it, remember not to shake the handle left and right to avoid damaging the blade.

The blade is sharp, be careful not to get cut

## INSTALLATION INSTRUCTIONS

### Installation

Install the V-shaped loading platform: ① Loosen the butterfly screw on the V-shaped loading platform (Figure 1), ② Install the loading platform on the machine as shown in the figure, paying attention to the high and low sides and the front and back reference directions (Figure 2). ③ Use the butterfly nut just removed to tighten the screw at the bottom of the machine

interfere with the tool handle up and down, which will cause damage to the blade).

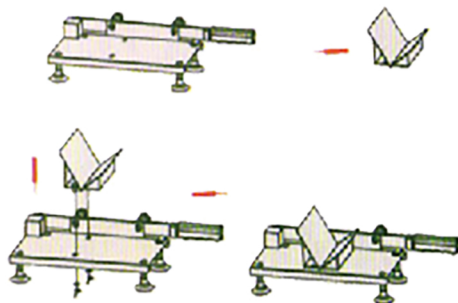

## PRODUCT PARAMETERS

Slicing speed: 65 slices/minute

Cleaning conditions: full body wash

## OPERATING INSTRUCTIONS

1. Place the machine on the workbench, let the suction cup stick to the table to fix the machine body, and place the standard meat roll or homemade meat roll on the V-shaped loading table;

2. Use your left hand to hold the meat press to press the frozen meat roll so that the meat roll is close to the knife rod. Use your right hand to hold the knife handle and press it down to complete a slicing action. Pick it up with your right hand, let the blade gently separate from the meat roll, use your left hand to gently move the meat roll close to the knife rod, use your right hand to hold the knife handle and cut down again, and repeat this process.

## THICKNESS ADJUSTMENT OPERATING INSTRUCTIONS

When you need to slice thin slices, first loosen the thickness "adjustment inner nut" clockwise to the desired thickness, then tighten the "adjustment outer nut" clockwise to tighten the "thickness adjustment plate" and "adjustment inner nut" and lock them. (Note: When adjusting the thickness, make sure that the two thickness adjustment knobs have the same adjustment number and the same scale, otherwise the thickness of the meat slices will be uneven. One turn of the adjustment nut is one millimeter, and the number of turns can be adjusted according to needs.)



## THINGS TO NOTE

1. Machine maintenance

1. Clean the machine parts that come into contact with food after use. Wash the machine body with water. Do not allow water to enter the handle bearing part. After washing, wipe off the water marks on the machine body with a dry cloth, and apply oil to the bearing part, blade and spring part to prevent rust.

2. When not in use for a long time, the blade should be wiped clean and dried. It is best to store the oiled blade separately in a dry place after oiling it.

2. Knife sharpening method

1. When the blade needs to be sharpened, please use a hexagonal wrench to loosen the screws on the blade, remove the blade, and sharpen it.

2. Blade edge angle: The blade edge is a bevel edge surface, and the reverse side is a straight edge surface. The angle between the bevel edge surface and the cutting edge surface is 1-8 degrees.

3. Place the roller sharpener on a flat and rough table. Hold the blade in your right hand with the bevel facing the grinding wheel. When sharpening the bevel, keep it as close to the side of the grinding wheel as possible and roll it on the table. The number of sharpening times depends on how blunt the blade is. Generally, 10 times is enough.

Focus on a better slicer for ten years

Pursue excellence and high quality to create a leading brand of food machinery