

Shark

Clean & Empty PowerDetect Cordless Vacuum

IP1000ANZ Series

IP3000ANZ Series

OWNER'S GUIDE



IMPORTANT SAFETY INSTRUCTIONS

FOR HOUSEHOLD USE ONLY • PLEASE READ ALL INSTRUCTIONS BEFORE USING THIS VACUUM.

To reduce the risk of shock and unintended operation, turn off power and remove the ION Power Pack battery before servicing.

NOTE: If you have delicate or wool carpets, particularly loop pile, please try the vacuum on a hidden area first to ensure the spinning brush-rolls do not damage or unpick carpet fibres.



⚠ WARNING

REDUCE THE RISK OF FIRE, ELECTRIC SHOCK, INJURY, OR PROPERTY DAMAGE:

1. This vacuum consists of a motorised nozzle, wand, and handheld vacuum. These components contain electrical connections, electrical wiring, and moving parts that potentially present risk to the user.
 2. Before each use, carefully inspect all parts for any damage. If a part is damaged, discontinue use.
 3. Use only identical replacement parts.
 4. This vacuum contains no serviceable parts.
 5. Use only as described in this manual. **DO NOT** use the vacuum for any purpose other than those described in this manual.
 6. With the exception of the filters and dust cup, **DO NOT** expose any parts of the vacuum to water or other liquids.
 - 7 **DO NOT** allow the appliance to be used by children. Keep the appliance and its cord out of reach of children. **DO NOT** allow to be used as a toy. Close supervision is necessary when used near children.
- ### GENERAL USE
8. This appliance can be used by persons with reduced physical, sensory or mental capabilities or lack of experience and knowledge if they have been given supervision or instruction concerning use of the appliance in a safe way and understand the hazards involved. Cleaning and user maintenance should not be done by children.
 9. Always turn off the vacuum before connecting or disconnecting any current carrying hoses, motorised nozzles, chargers, batteries, or other electrical or mechanical parts.
 10. **DO NOT** handle plug or vacuum with wet hands.
 11. **DO NOT** use without dust cup, filters, and brush-roll in place.
 12. Only use Shark branded filters and accessories. Damage caused by non-Shark filters and accessories may not be covered by the guarantee.
 13. **DO NOT** put any objects into nozzle or accessory openings. **DO NOT** use with any opening blocked; keep free of dust, lint, hair, and anything that may reduce airflow.
 14. **DO NOT** use if nozzle or accessory airflow is restricted. If the air paths or the motorised floor nozzle become blocked, turn the vacuum off. Remove all obstructions before you turn on the unit again.
 15. Keep nozzle and all vacuum openings away from hair, face, fingers, uncovered feet, or loose clothing.
 16. **DO NOT** use if vacuum is not working as it should, or has been dropped, damaged, left outdoors, or dropped into water.
 17. Use extra care when cleaning on stairs.
 18. **DO NOT** leave the vacuum unattended while powered on.
 19. When powered on, keep the vacuum moving over the carpet surface at all times to avoid damaging the carpet fibres.
 20. If you have delicate or wool carpets, particularly loop pile, please try the vacuum on a hidden area first to ensure the spinning brush-rolls **DO NOT** damage or unpick carpet fibres.
 21. **DO NOT** use to pick up:
 - a) Liquids
 - b) Large objects
 - c) Hard or sharp objects (glass, nails, screws, or coins)
 - d) Large quantities of dust (including Gyprock, fireplace ash, or embers). **DO NOT** use as an attachment to power tools for dust collection.
 - e) Smoking or burning objects (hot coals, cigarette butts, or matches)
 - f) Flammable or combustible materials (lighter fluid, petrol, or kerosene)
 - g) Toxic materials (chlorine bleach, ammonia, or drain cleaner)

22. **DO NOT** use in the following areas:
 - a) Wet or damp surfaces
 - b) Outdoor areas
 - c) Spaces that are enclosed and may contain explosive or toxic fumes or vapours (lighter fluid, petrol, kerosene, paint, paint thinners, mothproofing substances, or flammable dust)
23. Turn off the vacuum before plugging in or unplugging the charger.
24. Turn off the vacuum before any adjustment, cleaning, maintenance or troubleshooting.
25. During cleaning or routine maintenance, **DO NOT** cut anything other than hair, fibres, or string wrapped around the brush-roll.
26. Allow all filters to air-dry completely before replacing in the vacuum to prevent liquid from being drawn into electric parts.
27. **DO NOT** modify or attempt to repair the vacuum or the battery yourself, except as indicated in this manual. **DO NOT** use the battery or vacuum if it has been modified or damaged. Damaged or modified batteries may exhibit unpredictable behavior resulting in fire, explosion or risk of injury.
28. Turn off all controls before unplugging.
29. Always turn off this appliance before connecting or disconnecting motorised nozzle or hand tool.
30. If the supply cord is damaged, it must be replaced by the manufacturer, its service agent or similarly qualified persons in order to avoid a hazard.

BATTERY PACK

31. The battery is the power source for the vacuum. Carefully read and follow all charging instructions.
32. To prevent unintentional starting, ensure the vacuum is powered off before picking up or carrying the vacuum. **DO NOT** carry the appliance with your finger on the power switch.
33. For IP3000 Series, use only the XDCKIP3000ANZ charging dock (One battery can be charged). For IP1000 and IP3000 Series, use only with YLJX2I-A260100 charger.
34. Keep the battery away from all metal objects such as paper clips, coins, keys, nails, or screws. Shorting the battery terminals increases the risk of fire or burns.
35. Under abusive conditions, liquid may be ejected from the battery. Avoid contact with this liquid, as it may cause irritation or burns. If contact occurs, flush with water. If liquid contacts eyes, seek medical help.

36. Battery should not be stored at temperatures below 3°C or above 40°C to maintain long-term battery life.
37. **DO NOT** charge battery at temperatures below 5°C or above 40°C. Charging improperly or at temperatures outside of the specified range may damage the battery and increase the risk of fire.
38. Store the appliance indoors.
39. **DO NOT** expose the battery to fire or temperatures above 130°C as it may explode.
40. Use appliances only with specifically designated battery packs. Use of any other battery packs may create a risk of injury and fire.
41. Disconnect the battery pack from the appliance before making any adjustments, changing accessories, or storing appliance. Such preventive safety measures reduce the risk of starting the appliance accidentally.
42. Always ensure that the rechargeable battery is removed from the appliance before inserting into the battery charging sleeve. For IP1000 and IP3000 Series, use only Shark battery pack XBATR640EU (21.6V 3750mAh 8lwh).

ODOUR (IP3000 SERIES ONLY)

43. Observe the following when interacting with the Odour Neutraliser Technology cartridge:
 - a) **DO NOT** attempt to disassemble Anti-Odour Technology cartridge.
 - b) Avoid direct contact with the fragrance pod in the cartridge
 - c) **DO NOT** directly inhale from the Anti-Odour Technology cartridge.
 - d) Keep away from children and pets.
 - e) Keep away from heat, sparks, and open flame.

DO NOT place in direct sunlight.

FRAGRANCE CARTRIDGE FIRST AID

44. Observe the following when interacting with the Odour Neutraliser Technology cartridge:
 - a) Avoid contact with fabrics and finished surfaces.
 - b) Eye contact: Remove contact lenses if present. Rinse continuously with water or several minutes.
 - c) Skin contact: Wash hands thoroughly after handling. If irritation or rash develops, seek medical advice/attention.
 - d) Inhalation: Move person to fresh air if they are experiencing any respiratory symptoms. If symptoms persist, seek medical advice/attention.
 - d) Ingestion: **DO NOT** induce vomiting. Seek medical advice/attention.

AUTO-EMPTY ASSEMBLY (IP3000 SERIES)

1. Slide the **Wand** onto the neck of the **Floor Nozzle** until it clicks into place.
2. Align the **Hand Vacuum** nozzle opening with the top of the wand and slide it on until it clicks into place.
3. Make sure the **Dock Base** is facing upright. Slide the **Charging Post** into the slot on front of dock until it clicks.
4. Place the dock on the floor near a wall outlet. Plug the **Power Cord** into the outlet.
5. Store the crevice tool using **Accessory Storage** on the dock.
6. Refer to pages 8 and 9 for Odour Neutraliser Installation and Replacement instructions.

For proper operation, ensure all components are completely connected and clicked into place.

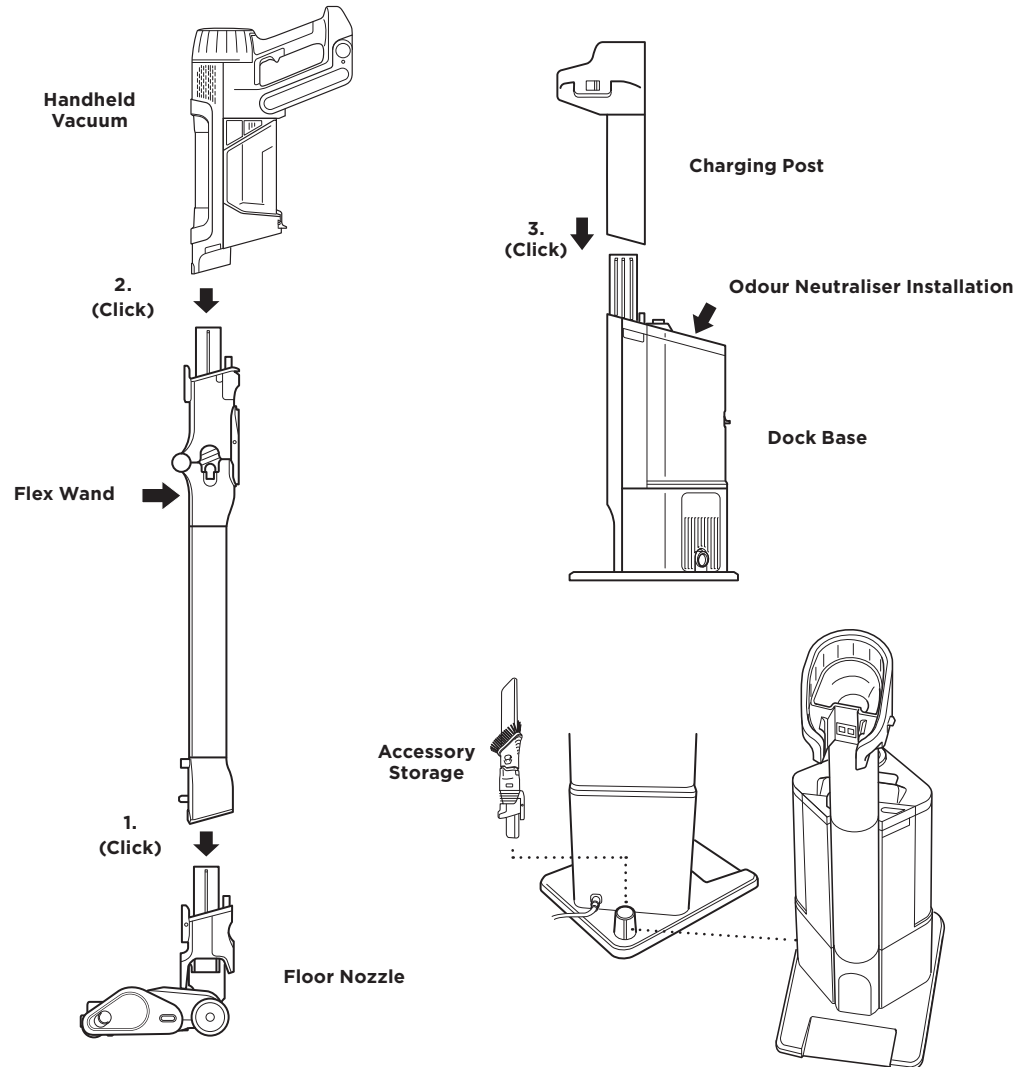

NOTE: Once the charging post is installed, it cannot be removed.

NON-AUTO-EMPTY ASSEMBLY (IP1000 SERIES)

1. Slide the **Wand** onto the neck of the **Floor Nozzle** until it clicks into place.
 2. Align the **Hand Vacuum** nozzle opening with the top of the wand and slide it on until it clicks into place.
- For proper operation, ensure all components are completely connected and clicked into place.

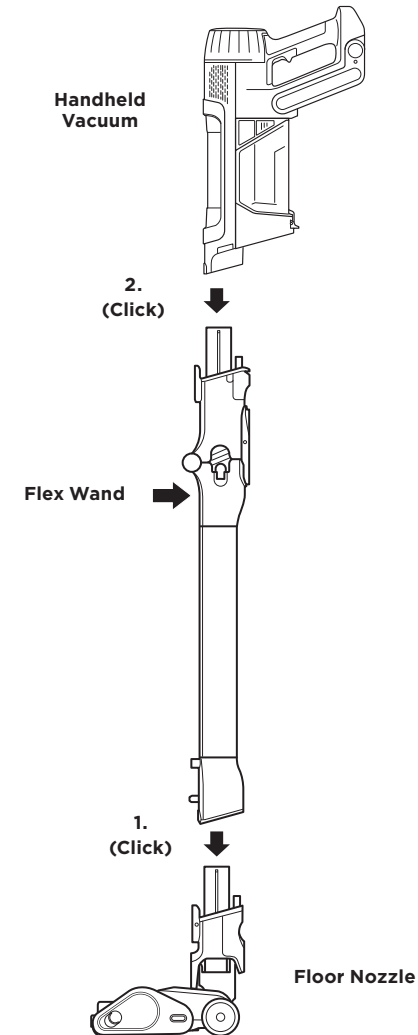

ODOUR NEUTRALISER TECHNOLOGY (IP3000 SERIES)

ADJUSTING THE ODOUR NEUTRALISER TECHNOLOGY INTENSITY

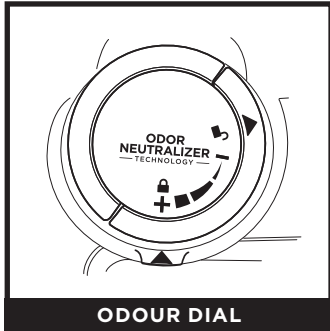

Flip up the dial handle and rotate the odour dial to adjust odour neutraliser technology intensity or to unlock the dial for cartridge access.

Insertion/Removal: Rotate the odour dial to align the teal arrows. Remove the dial to access the odour cartridge for removal or replacement.

Low: Rotate the dial toward the Low position to decrease the intensity to the lowest level when the vacuum is in use.

High: Rotate the dial toward the High position for the highest intensity level when the vacuum is in use. This position is the recommended setting for optimal performance.

ODOUR NEUTRALISER TECHNOLOGY TIPS (IP3000 SERIES)

The Odour Neutraliser Technology Dial Must be Installed for Vacuum to Function Properly

- Remove Odour Neutraliser cartridge from dial if you don't want the benefits of the Odour Neutraliser Technology.

Maintenance Required

- Clean all filters as recommended under Cleaning Filters.
- Empty the dust cup before storing your vacuum.
- Replace the cartridge as recommended under Odour Cartridge Replacement.
- Visit sharkclean.co.uk to learn more and purchase replacements.

Fragrance Strength Over Time

- The intensity of the Odour Neutraliser Technology's fragrance may diminish over time. It may also have no noticeable fragrance at all. This is natural and does not indicate the technology isn't working. Follow replacement instructions to ensure continued performance.

NOTES: • The odour dial needs to be installed for the vacuum to function properly, with or without the odour cartridge.

ODOUR NEUTRALISER TECHNOLOGY (IP3000 SERIES)

ODOUR CARTRIDGE REPLACEMENT



Flip up the handle and rotate the dial clockwise until the two arrows are aligned. Pull the handle to remove the dial from the auto-empty dock.

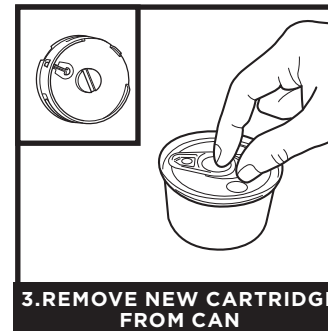

Remove the new Odour Neutraliser cartridge from the can. To maintain the life of the cartridge, keep it in the can until you are ready to install it.



Align the teal arrow on the dial cover with the arrow on the auto-empty dock, then reinsert the dial into the auto-empty dock. Rotate the dial counterclockwise until it clicks into an intensity setting to engage. Rotate further to change the intensity setting.

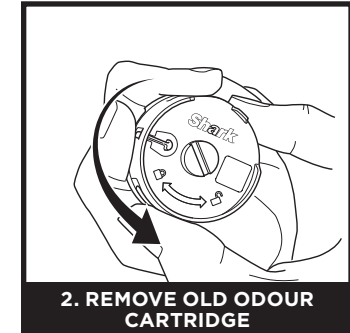

Rotate the cartridge counterclockwise in the dial housing and pull out the cartridge to remove it.

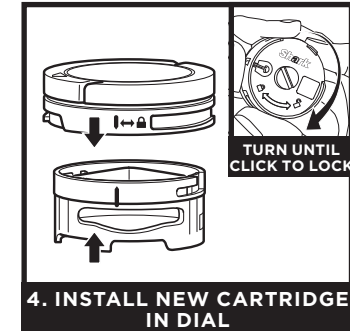

Align the yellow arrow on the side of the cartridge with the yellow arrow on the side of the dial cover, then insert the cartridge into the dial. Rotate the cartridge clockwise to lock it in place.



Dispose of the old cartridge by dropping it into the bin.

NOTE: Odour cartridges should be replaced every 6 months for optimal odour neutraliser technology performance.

CHARGING YOUR LI-ION BATTERY

Prior to first use, charge the battery completely. A full charge takes approximately 5 hours.

RUNTIMES PER FULLY CHARGED BATTERY

With a full charge, the unit will have up to a 70-minute runtime. Visit sharkclean.com.au or sharkclean.co.nz online for more information.

LED BATTERY POWER AND CHARGING INDICATORS

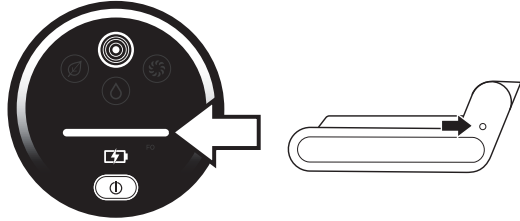

NOTE: Battery consumption will vary depending on the mode being used:

ECO - Maximum Runtime, saves battery power

DETECT - Optimises suction and power for maximum cleaning

BOOST - Maximises suction. Uses the most battery power

Charging

 LED on the battery pack will pulse yellow when reaching 0-75% charge.

 LED on the battery pack will pulse green from 75% - 100% charge.

 White LED the battery pack is fully charged.

NOTE: Full charge takes approximately 6 hours.

Additional Notes

1. LEDs turn off once the battery is fully charged.
2. Unit will not power on when charger is connected.

BATTERY CHARGING INFORMATION



RECYCLING THE LI-ION BATTERY

When the Shark Li-ion battery needs to be replaced, dispose of it or recycle it in accordance with local ordinances or regulations. In some areas, it is illegal to place spent lithium-ion batteries in the standard rubbish bin. Return spent batteries to an authorised recycling centre or to the retailer for recycling. Contact your local recycling centre for information on where to drop off the spent battery.

NOTE: The Shark battery, like all lithium-ion batteries, will naturally decrease in capacity over time from the 100% capacity of a new battery.

CHARGING YOUR LI-ION BATTERY

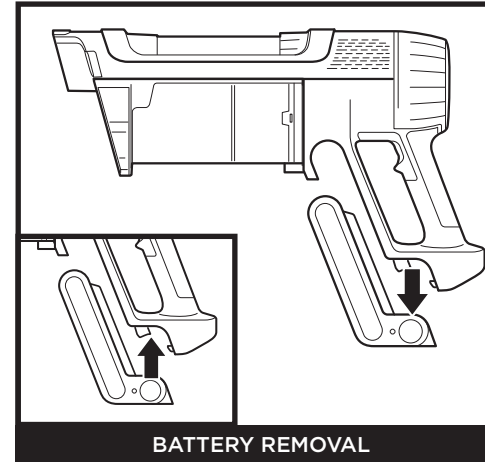

BATTERY REMOVAL

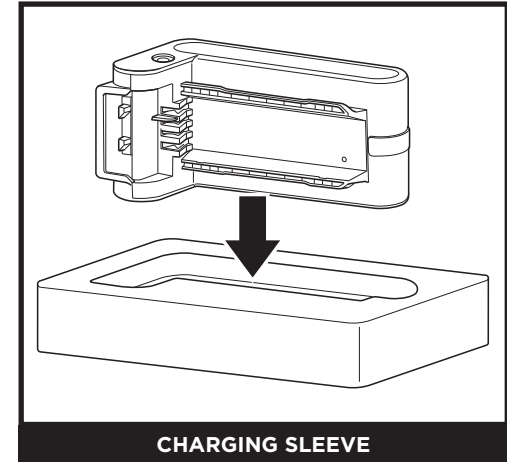

CHARGING SLEEVE

To remove the battery from the vacuum, press the release button on the battery and slide out of the handle compartment. To reinstall, slide the battery back into the compartment until it clicks into place.

To charge the battery, remove it from the vacuum and insert into the charging sleeve. Once the battery is showing as fully charged reinsert into the handle compartment on the vacuum (see charging indicators on previous page)

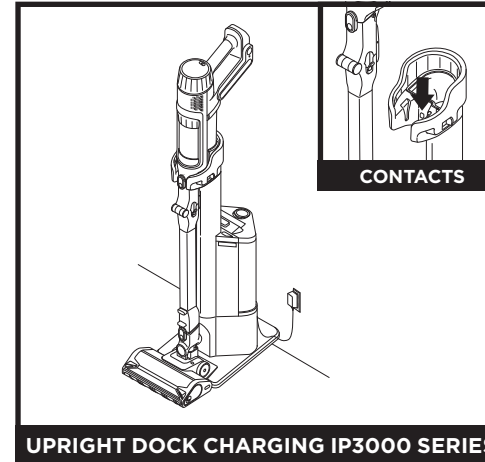

UPRIGHT DOCK CHARGING IP3000 SERIES

Charge the unit by placing it on the dock. Make sure the contacts on the wand are aligned with the contacts on the charging post. When charging is complete and you need to use the unit again, lift it off the dock.

NOTE: When the unit is docked properly, the charging lights on the battery will blink, indicating that charging has begun.

NOTE: The main unit comes with a partial charge. For maximum runtime, charge fully before first use (approximately 5 hours). Leaving the unit plugged in will not damage battery life.

USING YOUR VACUUM

CONTROLS AND CLEANING MODES

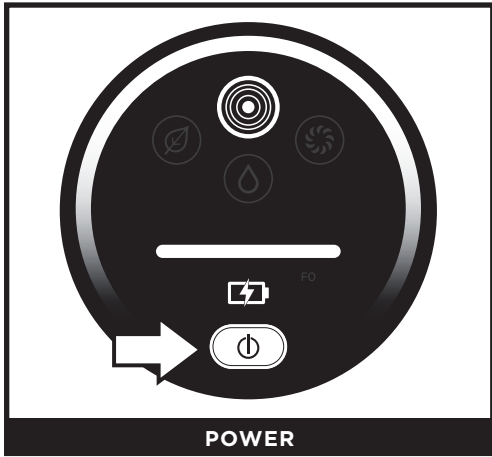

POWER

Press the $\text{\textcircled{P}}$ button on the UI Screen to turn on power. To turn off power, press the button again.

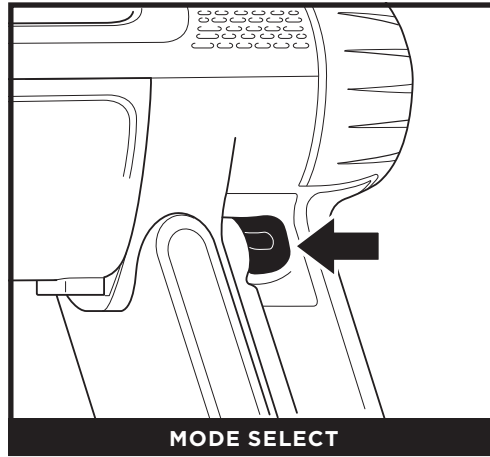

MODE SELECT

To toggle between ECO, DETECT, and BOOST modes, press the mode selection trigger on the handle (shown above). In DETECT mode, Detect Technology automatically adjusts vacuum and nozzle power to maximise cleaning performance and optimise runtime.

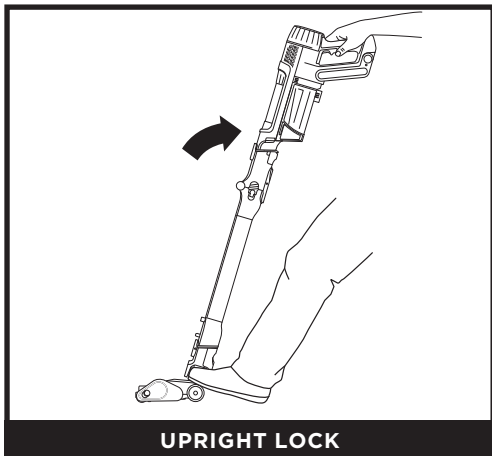

UPRIGHT LOCK

To begin cleaning with the floor nozzle, disengage the lock by stepping on the nozzle and tilting the hand vac down.

NOTE: For - Best Cleaning on ASTM and IEC Cleaning Tests, Use **Boost** Mode.

USING YOUR VACUUM

DETECT TECHNOLOGY EXPLAINED

NOTE: Detect Technology is ONLY operational in Detect Mode and is activated automatically when the unit is in use.

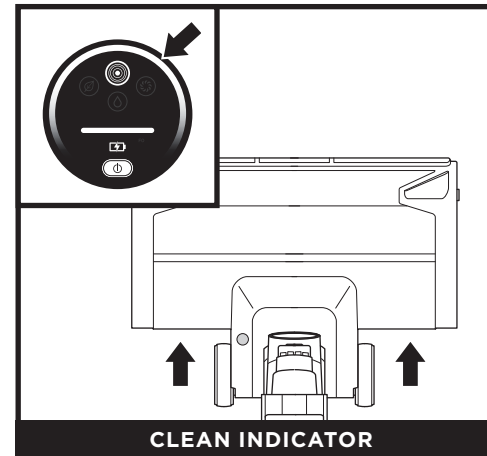

CLEAN INDICATOR

Vacuum identifies dirtier areas and automatically boosts suction power to pull in hidden dirt.

White LED = No heavy debris detected, low suction
Light Purple LED = Debris is being cleaned, medium suction
Deep Purple LED = Heavy debris detected, high suction

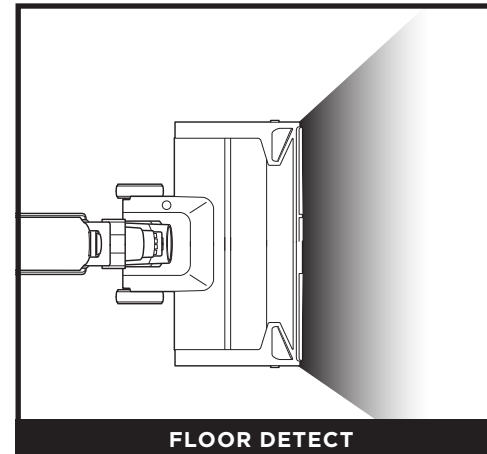

FLOOR DETECT

Brushroll and vacuum responds to surface changes and automatically adjusts to optimise your clean.

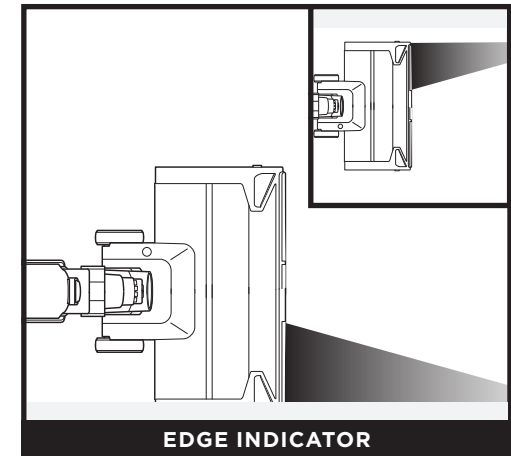

EDGE INDICATOR

Vacuum floor nozzle detects edges and corners and maximises suction and power to remove stubborn dirt.

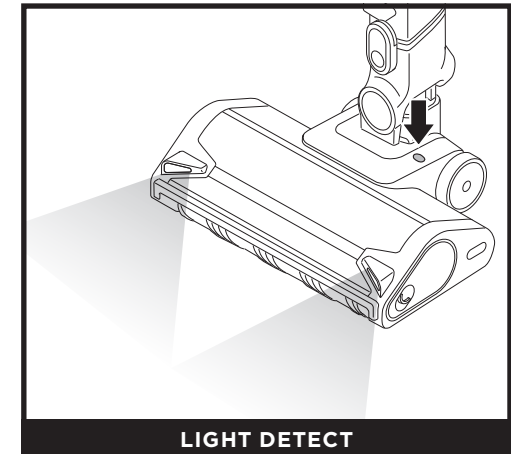

LIGHT DETECT

Senses low-light situations and automatically illuminates dark areas to help you spot debris.

USING YOUR VACUUM

MULTI-FLEX WAND

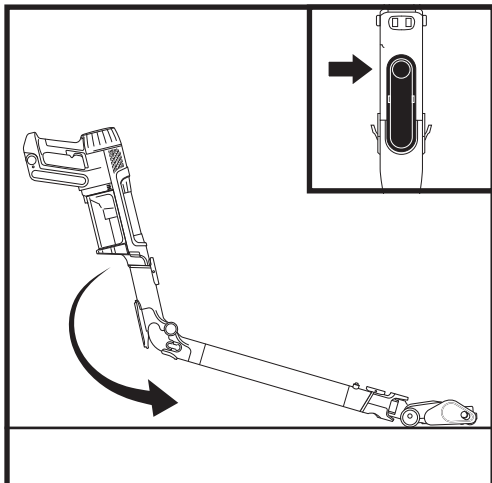

Multi-Flex Wand allows you to flex the wand to reach under furniture and clean debris in hard-to-reach areas.

To engage the Multi-Flex Wand feature, press the unlock button on the back of your Flex Wand.

For straight wand cleaning, return the wand to its original angle. You will hear a click when it is securely back in place.

STORAGE

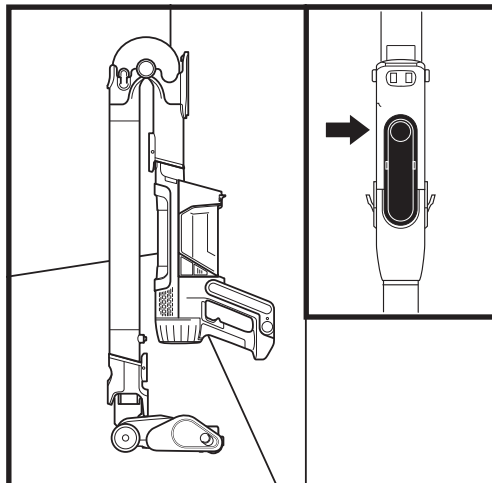

To put the vacuum into storage mode, press the Multi-Flex Wand wand unlock button while folding the handheld vacuum forward until it is resting against the wand.

To release vacuum from storage mode, unfold the vacuum until the wand straightens and clicks securely back in place.

USING YOUR VACUUM

ABOVE-FLOOR CLEANING

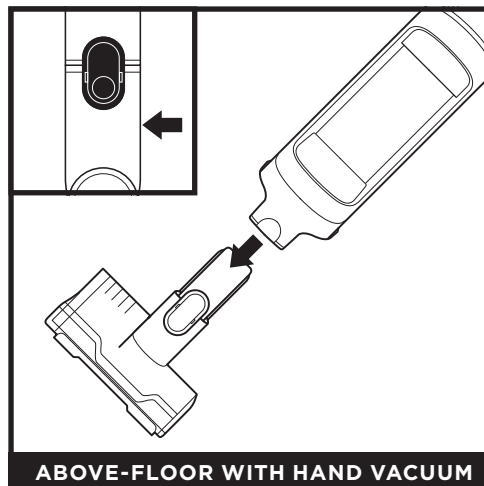

ABOVE-FLOOR WITH HAND VACUUM

Detach the hand vacuum to clean above-floor areas. Press the front latch release button on the hand vac where it meets the wand, then lift off the hand vacuum. To attach an accessory to the hand vacuum, slide it into the opening in the nozzle. To remove, press the front latch release button on the hand vac where it meets the wand, and slide out the accessory.

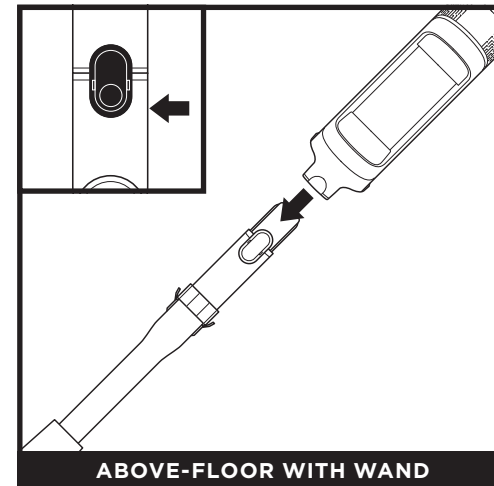

ABOVE-FLOOR WITH WAND

To detach the floor nozzle from the wand, step on the nozzle while pressing the nozzle release button at the bottom of the wand. Lift the wand to remove it. To reattach the wand, align it over the neck of the floor nozzle, then slide it on until it clicks into place.

USING YOUR VACUUM

USING THE AUTO-EMPTY DOCK (IP3000 SERIES)

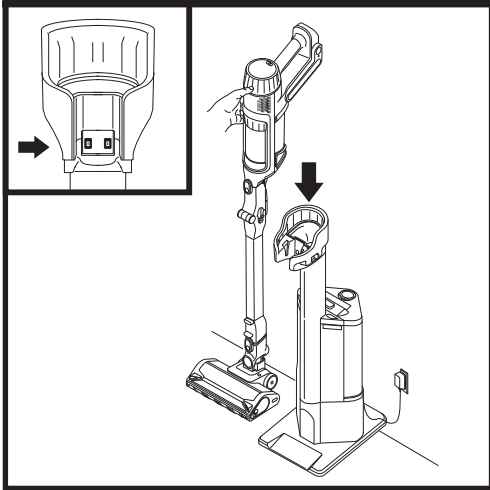

Place the vacuum on the dock in a downward motion. Once properly attached, the auto evacuation process will begin. The evacuation cycle will last for 15 seconds.

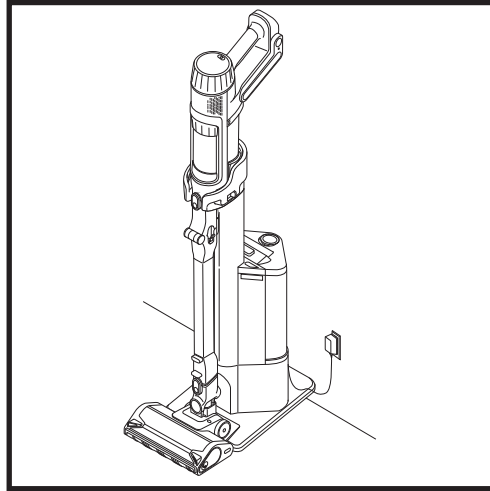

Once evacuation is complete, the vacuum will continue charging until it is removed from the dock.

MAINTAINING YOUR VACUUM

EMPTYING THE DOCK DUST BIN (IP3000 SERIES)

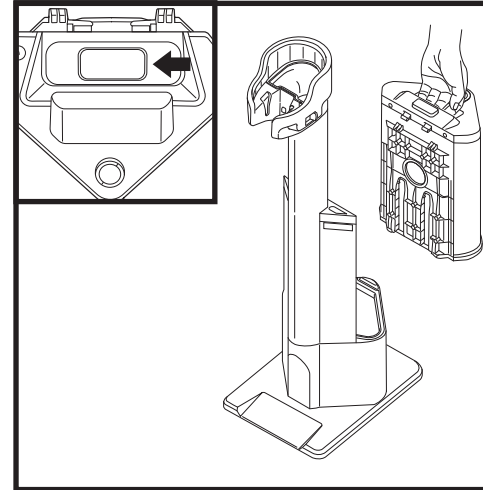

The dock dust bin holds up to 45 days' worth of dust and debris. Empty the dock dust bin when the dust bin full indicator light comes on. To remove the bin, lift it out by the handle.

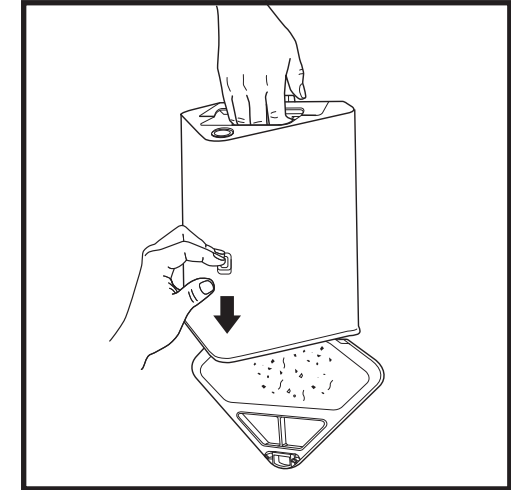

To empty the bin, hold it over the rubbish bin and press the release button on the side. The bottom will open to release the debris.

CLEANING THE AUTO-EMPTY DOCK FILTER

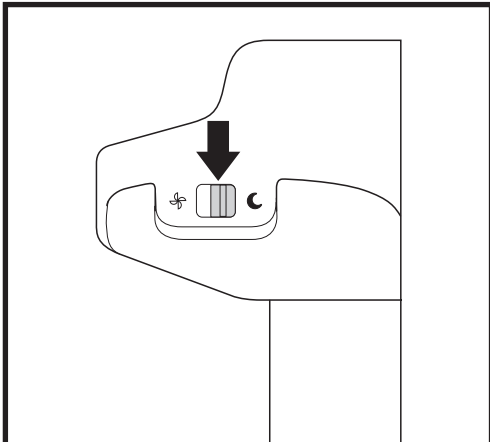

QUIET MODE

Use Quiet Mode to dock and charge the vacuum without automatic evacuation. To activate Quiet mode, press the moon switch on top of the charging post.

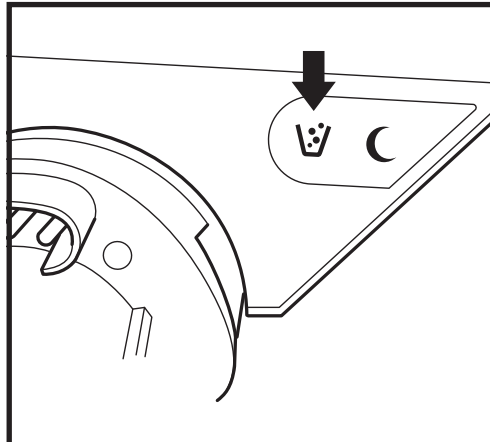

DUST BIN FULL INDICATOR

The Dust Bin Full indicator will illuminate when the dust bin is full of debris and needs to be emptied. To reset the indicator, remove the dust bin and empty it.

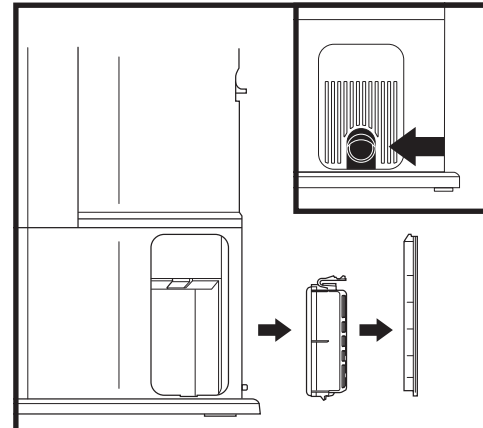

To access the filter in the dock, Press the button at the bottom of the door, then tilt the door and lift it off. Remove the filter from the dock. After the filter has been cleaned, reinstall it by reinserting back into the dock and replacing the filter door.

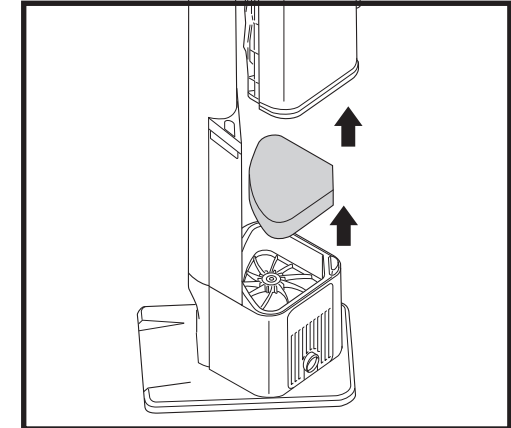

Filter, remove the dust bin. Before removing the Exhaust Foam Filter, remove any fine debris from the surface using the hand vacuum. Lift the Exhaust Foam Filter out of the dock to clean and then reinstall.

Note: Do not remove the vacuum while the evacuation cycle is taking place.

CLEANING THE HEPA FILTER (IP1000 SERIES)

NOTE: Rinse the HEPA filter at least once a month to maintain suction power. More frequent cleaning may be necessary with heavy use. To clean the filter, rinse it with water only and allow it to air-dry completely for up to 48 hours before reinstalling. Tap off loose dirt between washes when needed.

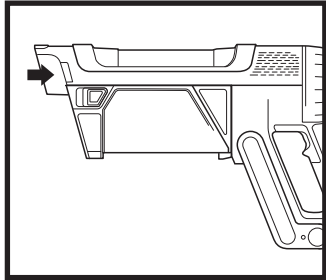

1. To access HEPA filter, first press the dust cup empty button to open the dust cup. Then press the dust cup release button and slide the dust cup off the hand vac.

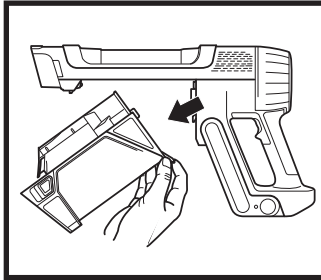

2. Press the filter release button and gently pull the HEPA filter out of the hand vac.
3. After the filter has been rinsed and air-dried completely, slide it back into the hand vacuum.

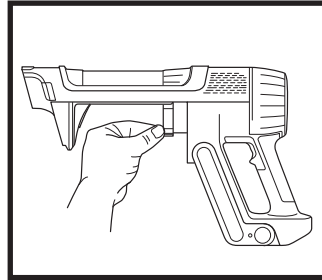

4. For IP1000 Series only: to release dust and debris into the trash, pull the lever on the bottom of the dust cup and the bottom lid will open.

CLEANING THE HEPA FILTER (IP3000 SERIES)

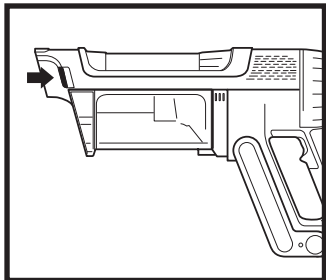

1. To access the HEPA filter, press the Dust Cup Empty button to open the dust cup, then press the release button and slide the dust cup off the hand vac.

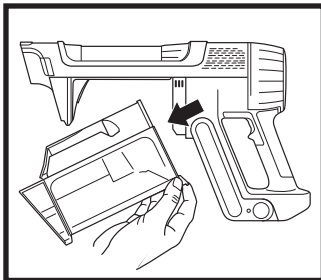

2. Press the filter release button and gently pull the HEPA filter out of the hand vac.
3. After the filter has been rinsed and air-dried completely, slide it back into the hand vacuum.

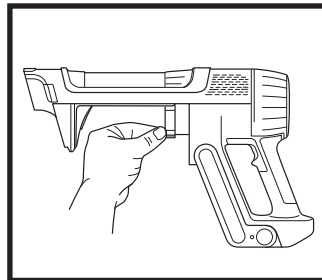

4. For IP3000 Series only: to release dust and debris into the trash, pull the lever on the bottom of the dust cup and the bottom lid will open.

IMPORTANT: DO NOT use soap when cleaning the filters. Use water only. The vacuum will not have suction if the post-motor filter is not installed. Ensure that all filters are installed before using.

EMPTYING THE HANDHELD VACUUM DUST CUP (IP1000 SERIES)



To empty the handheld vacuum dust cup, turn off the power and hold the vacuum directly over the rubbish bin. Press the release button and the dust cup lid will drop open, releasing debris.

MAINTAINING YOUR VACUUM

NOZZLE MAINTENANCE

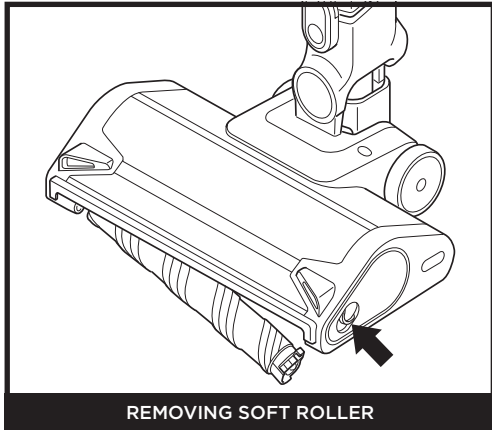

1. Turn off the vacuum.
2. Press the nozzle release button to detach the nozzle from the wand.
3. Press the soft roller release button and slide the soft roller out of the nozzle.
4. Clear any blockages and remove any debris from the soft roller and floor nozzle.
5. Tap off loose debris and wipe the soft roller clean with a dry towel. Hand wash the soft roller if needed, using only water, and then let it air dry completely before reinstalling.
6. When the soft roller is completely dry, reinstall it into the nozzle by inserting it into the nozzle until it clicks.

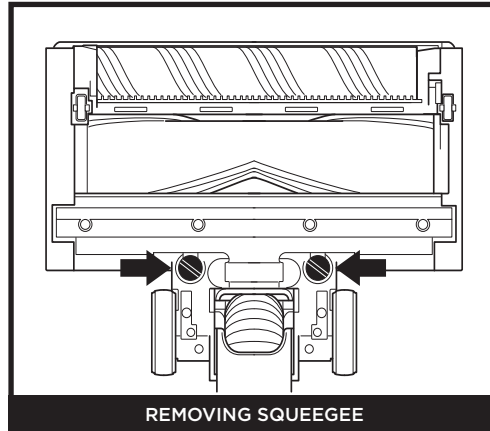

1. Turn off the vacuum.
2. Press the nozzle release button to detach the nozzle from the wand.
3. Remove rear squeegee by turning screws.
4. Clear out any blockages and debris from behind the squeegee.
5. Reinstall squeegee and turn screws until they lock into place.

MAINTAINING YOUR VACUUM

CLEANING THE SENSORS

Make sure to clean the Detect sensors regularly, as hair and other debris may build up and obstruct them. If the sensors are partially obstructed, Clean Sense Detect mode will not function as expected.

To clean the sensors:

1. Turn off power and remove the floor nozzle.
2. Locate the Dirt Detect Sensor in the nozzle of the hand vac (Fig. 1), the Light Detect Sensor on the top of the nozzle (Fig. 2), the Edge Detect sensor on the side of the nozzle (Fig. 3), and the Floor Detect Sensor (Fig 4) on the bottom of the nozzle.
3. Gently wipe the sensors with a microfibre cloth and remove all hair and debris.
4. Reattach the floor nozzle to the rest of the unit and turn on power. Verify that the unit is functioning normally.

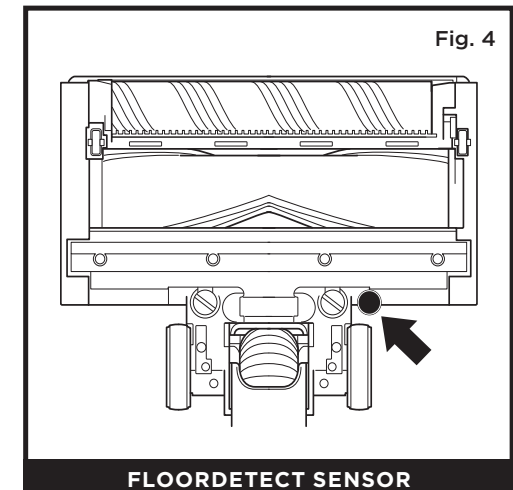
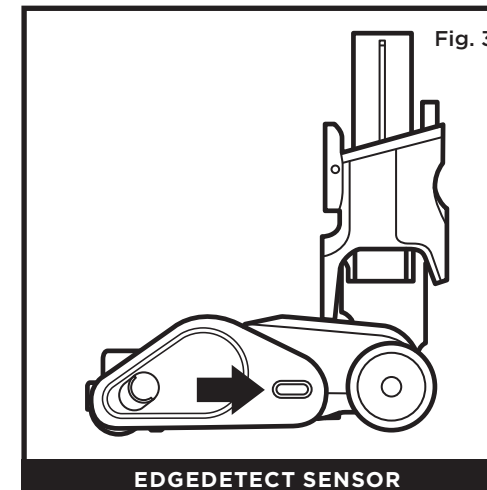
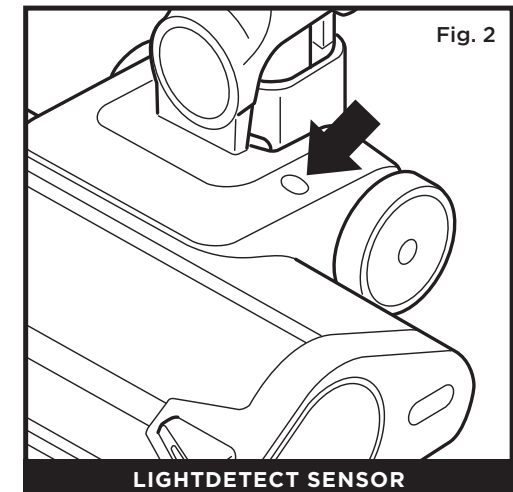
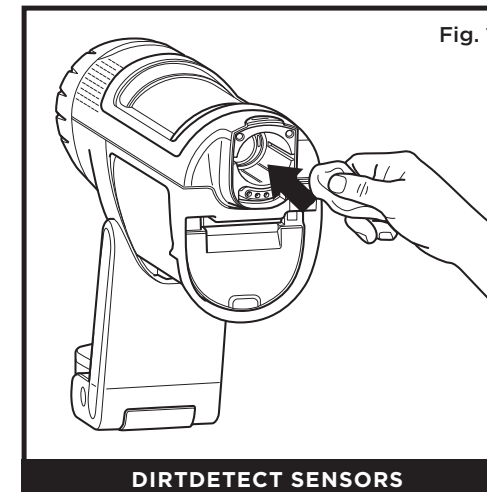

CHECKING FOR BLOCKAGES IN THE VACUUM

If you run over a hard or sharp object or notice a noise change while vacuuming, check for blockages or objects caught in the brushroll.

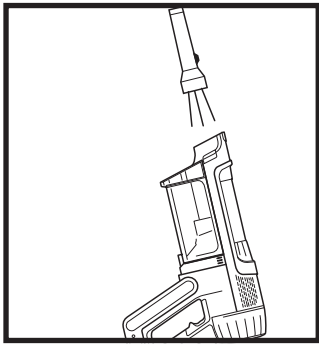

Checking for Blockages in the Hand Vacuum:

1. Turn off the vacuum.
2. Remove the hand vacuum from the wand.
3. Check all intake openings to the dust cup and remove any debris or blockages.

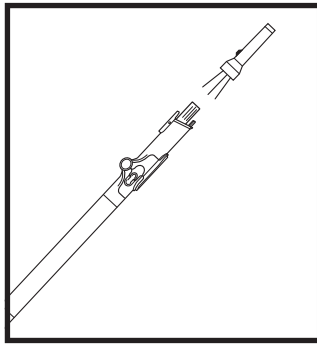

Checking for Blockages in the Wand:

1. Turn off the vacuum.
2. Detach the hand vacuum and floor nozzle from the wand.
3. Check both ends of the wand for blockages and debris.
4. Clear away any debris or blockages.

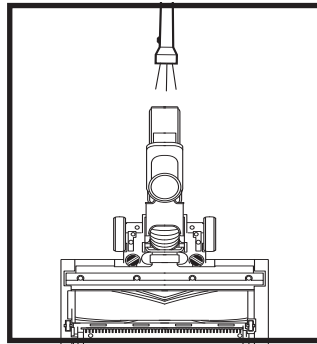

Checking for Blockages in the Floor Nozzle:

1. Turn off the vacuum.
2. Detach the wand from the floor nozzle.
3. Press the soft roller release button and slide the brushroll out of the nozzle.
4. Clear any blockages and release any debris from the brushroll and floor nozzle.
5. Slide the soft roller back into the nozzle, ensuring everything is lined up and in place.

CHECKING FOR BLOCKAGES IN THE AUTO-EMPTY DOCK (IP3000 SERIES)

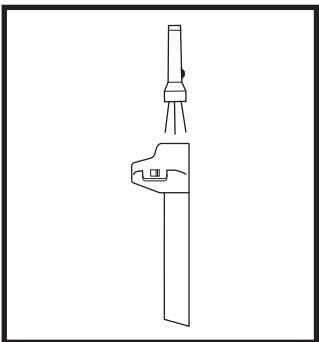

Checking for Blockages in the Charging Post:

1. Unplug the dock.
2. Remove the vacuum from the dock.
3. Press the latch on the back of the charging post and lift the post away from the dock.
4. Check the end of the charging post and top of the dock for any debris or blockages.

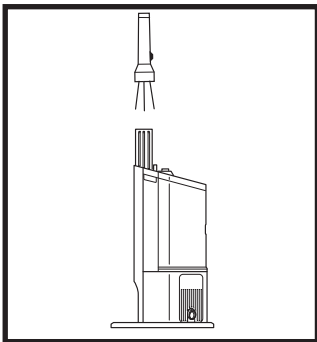

Checking for Blockages in the Dock:

1. Unplug the dock.
2. Remove the vacuum from the dock.
3. Remove the dust bin from the dock.
4. Check the exit for any debris or blockages.

TROUBLESHOOTING

WARNING: To reduce the risk of shock and unintended operation, turn off power and remove the battery before servicing.

Vacuum is not picking up debris. No suction or light suction. Third indicator light on hand vacuum is solid yellow. (Refer to Checking for Blockages section for more information.)

1. Dust cup may be full; empty dust cup.
2. Check floor nozzle for blockages; clear blockages if required.
3. Remove any string, carpet fibers, or hair that may be wrapped around the brushroll.
4. Check connection between hand vacuum and wand for blockages; clear blockages if required.
5. Check filters to see if they need cleaning. Follow instructions for rinsing and completely air-drying the filters before reinstalling them.

Vacuum lifts area rugs.

1. Make sure you are not engaging Boost mode. Take care when vacuuming area rugs or rugs with delicately sewn edges.
2. Turn off the unit to disengage from the carpet, then restart.

The brushroll in the floor nozzle doesn't spin.

1. Immediately turn off the vacuum. Remove any blockages before turning the vacuum back on. Make sure the hand vacuum is tilted back far enough for the brushroll to engage while in use.
2. If the floor nozzle has headlights and they are not illuminated, there is a connection issue between the hand vacuum, wand, and nozzle. Try detaching the parts, then reconnecting them.

Vacuum turns off on its own.

There are several possible reasons for the vacuum turning off on its own, including blockages, battery issues, and overheating. If vacuum turns off on its own, perform the following steps:

1. Turn on the vacuum and check the battery indicator lights on the hand vacuum. If recharging is needed, make sure vacuum power is off placing it on the charging dock.
2. Empty dust cup and clean filters (See the Cleaning the Dust Cup and Filter section).
3. Check wand, accessories, and inlet openings and remove any blockages.
4. Allow unit and battery to cool for at least 45 minutes, until they return to room temperature.
5. Press the On/Off switch to restart the vacuum.

Error Message Codes

Malfunction	Component	Error icons phase 1	Error icons phase 2	LED Icons
Nozzle Clog or Stalling	Nozzle	LED Ring is Flashing Purple ↔	No LEDs	
Motor Failure During Startup	Hand Vacuum	ECO, BOOST LEDs on ↔	ECO, DETECT LEDs on	
Over-Temperature Protection	Hand Vacuum	ECO, DETECT, BOOST LEDs on ↔	BOOST, DETECT LEDs on	
Over Current protection	Hand Vacuum	ECO, DETECT, BOOST LEDs on ↔	No LEDs	
Short Protection	Hand Vacuum	ECO, DETECT LEDs on ↔	No LEDs	
Overspeed Protection	Hand Vacuum	DETECT LEDs on ↔	ECO, BOOST LEDs on	
Communication Failure	Hand Vacuum	ECO, DETECT LEDs on ↔	DETECT, BOOST LEDs on	
Over-Temperature Protection	Nozzle	ECO, BOOST LEDs ↔	No LEDs	
Short Protection	Nozzle	DETECT, BOOST LEDs on ↔	No LEDs	
Debris Detection Failure	Hand Vacuum	FO LED & LED Ring on ↔	No LEDs	
Edge Detect Error	Nozzle	FO LED on, LED Ring on & Headlight LEDs on ↔	No LEDs	

NOTE: Error icons will blink for 0.5 seconds

NOTE: If vacuum still does not operate properly, contact Customer Service on **AU: +61 2 8801 7666 | NZ: +64 800 112 660**

ADDITIONAL ACCESSORIES AVAILABLE

- A** Crevice Tool
- B** Duster Crevice Tool
- C** Flexible Crevice Tool
- D** Anti-Allergen Brush
- E** Multi-Surface Tool
- F** Motorised Hand Tool
- G** Wide Upholstery Tool
- H** Car Detail Kit
- I** Replacement Battery
- J** Hand Vacuum Pre-Motor Filter
- K** Hand Vacuum Post-Motor Anti-Allergen Filter
- L** Auto-Empty Dock Post-Motor Filter
- M** Auto-Empty Exhaust Foam Filter
- N** Battery Charging Sleeve
- O** Accessory Dock

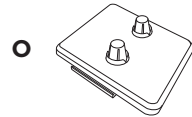
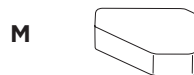
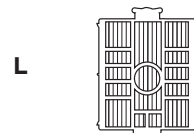
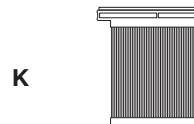
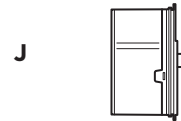
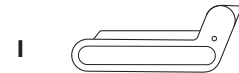
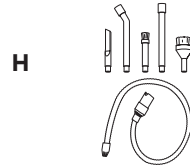
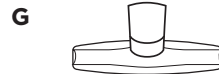
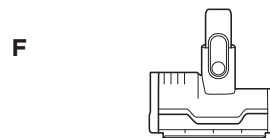
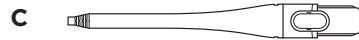

Shark | NINJA

TWO (2) YEAR LIMITED REPLACEMENT WARRANTY

For guarantee claims, you will need to submit a proof of purchase in the form of a valid receipt that displays date and place of purchase. This warranty does not replace but is in addition to your statutory rights.

If your product becomes defective due to faulty material or workmanship within a period of 2 years from the date of purchase, we warrant to do the following:

- **For New Zealand Consumers:** We will replace the defective/faulty part with a new product, free of charge or if the unit is deemed defective/faulty we replace the unit with an equivalent or upgraded model, at our discretion.
- **For Australian Consumers:** Our goods come with guarantees that cannot be excluded under the Australian Consumer Law. You are entitled to a replacement or refund for a major failure and for compensation for any other reasonably foreseeable loss or damage. You are also entitled to have the goods repaired or replaced if the goods fail to be of acceptable quality and the failure does not amount to a major failure.

Replacement items will be covered by the limited warranty for the balance of the warranty period from the date of the original purchase. **Please note: Your warranty is subject to the following conditions:**

- **DO NOT** operate the appliance with a damaged plug or cord or if the unit has been dropped, damaged or dropped in water.
- To avoid the risk of electric shock, do not disassemble or attempt to repair the appliance on your own. If the supply cord is damaged, it must be replaced by a qualified electrician to avoid a hazard. Incorrect re-assembly or repair can cause a risk of electric shock or injury to persons when the appliance is used.
- The item has not been misused, abused, neglected, altered, modified or repaired by anyone. The item has been subjected to fair wear and tear.
- The item has not been used for trade, professional or hire purposes.
- The item has not sustained damage through foreign objects, substances or accident

What is not covered?

- Accessories supplied with the item.
- Components that are subject to natural wear and tear caused by normal use in accordance with operating instructions.
- Unauthorised/improper maintenance/handling or overload is excluded from this warranty.

NOTE: Not all accessories come with all units. Please see the Quick Start Guide on the packaging box for your unit's configuration. To order additional accessories, visit sharkclean.com.au | sharkclean.co.nz.

THANK YOU

for purchasing the Shark Power Detect Cordless Vacuum.



TIP: You can find the model and serial numbers on the QR code label located on the back of your unit.



TIP: You can locate the date code on one of the prongs of the power cord plug.

Odour Neutraliser Technology



DANGER

If in direct contact with contents of cartridge:
May cause an allergic reaction to skin.

Wear protective gloves if directly coming into the contact with the cartridge. Wash skin thoroughly after handling. Harmful if swallowed. Avoid breathing in mist or vapours, intentional misuse and directly inhaling contents may be dangerous. Avoid release to the environment. Very toxic to aquatic life with long lasting effects, ensure cartridge is disposed of correctly as general waste.

2-(4-tert-butylbenzyl) propionaldehyde

May damage fertility and suspected of damaging the unborn child. Do not handle until all safety precautions have been read and understood. Use personal protective equipment, such as protective gloves, as required.

REGISTER YOUR PURCHASE

TO BENEFIT FROM YOUR PRODUCT'S EXTENDED GUARANTEE, SIMPLY REGISTER YOUR PURCHASE AT:

 registeryourshark.com

 AU 02 8801 7666
NZ 0800 112 660

 Scan QR code using mobile device

Please note, products purchased directly from Shark are automatically registered.

Benefits of registering your product and creating an account:

- Get easier, faster product support and access to guarantee information
- Access troubleshooting and product care instructions
- Be among the first to know about exclusive product promotions

RECORD THIS INFORMATION

Model Number: _____

Serial Number: _____

Date Code: _____

Date of Purchase (Keep Receipt): _____

Store of Purchase: _____

TECHNICAL SPECIFICATIONS

Voltage: 21.6V

Body Motor Watts: 850W

Nozzle Watts: 120W

PLEASE READ CAREFULLY AND KEEP FOR FUTURE REFERENCE.

This instruction manual is designed to help you get a complete understanding of your new Shark Power Detect Cordless Vacuum.

If you have any questions, please contact Customer Service at **AU 02 8801 7666 | NZ 0800 112 660**

AU sharkclean.com.au | **NZ** sharkclean.co.nz

NOTES

NOTES

ODOUR NEUTRALISER SPECIFICATIONS

1. Product Name: Odour Neutraliser Cartridge
2. Manufacturer: Shark Ninja 89 A Street, Needham, MA 02494
3. Weight: 17.4g / 0.61oz
4. Ingredients: Solid SM composite polymer C17 + fragrance SE 446676



SHARKNINJA PTY. LTD.

Suite 2, Level 23
45 Clarence St
Sydney NSW 2000

sharkclean.com.au | sharkclean.co.nz

Illustrations may differ from actual product. We are constantly striving to improve our products; therefore the specifications contained herein are subject to change without notice.

© 2025 SharkNinja Operating LLC. SHARK and MULTIFLEX are registered trademarks of SharkNinja Operating LLC. FLOOR DETECT, LIGHT DETECT, and POWERDETECT are trademarks of SharkNinja Operating LLC.

RBRC is a trademark of Rechargeable Battery Recycling Corporation.

SCF_IP1000-3000ANZ Series_IB_REV_Mv2



@sharkhomeau
@sharkhomenz