

MANUALE D'USO

MONTALATTE

INSTRUCTION MANUAL

MILK FROTHER

MANUEL D'UTILISATION

MOUSSEUR À LAIT

BEDIENUNGSHANDBUCH

MILCHAUFSCÄUMER

GEBRUIKSAANWIJZING

MELKOPSCHUIMER

MANUAL DE USO

ESPUMADOR DE LECHE

MANUAL DE UTILIZAÇÃO

BATEDOR DE LEITE

BRUKSANVISNING

MJÖLKSUMMARE

РУКОВОДСТВО ПО ЭКСПЛУАТАЦИИ

ВСПЕНИВАТЕЛЬ МОЛОКА

BRUGERVEJLEDNING

MÆLKESKUMMER

INSTRUKCJA OBSŁUGI

SPIENIACZ DO MLEKA

KÄYTTÖOPAS

MAIDONVAAHDOTIN

BRUKSANVISNING

MELKESKUMMER

دليل التعليمات

صانعة رغوة الحليب

 smeg

IT

EN

FR

DE

NL

ES

PT

SV

RU

DA

PL

FI

NO

AR

Informazioni importanti per l'utente  
Important information for the user  
Informations importantes pour l'utilisateur  
Wichtige Informationen für den Benutzer  
Belangrijke informatie voor de gebruiker  
Información importante para el usuario  
Informações importantes para o utilizador  
Viktig information för användaren  
Важная информация для пользователя  
Viktig information til brukeren  
Ważne informacje dla użytkownika  
Tärkeittä tietoja käyttäjälle  
Viktig informasjon for brukere  
معلومات هامة للمستخدم



Avvertenze / Recommendations / Avertissements / Hinweise /  
Waarschuwingen / Advertencias / Advertências / Varningar /  
Меры предосторожности / Advarsler / Ostrzeżenia / Varoituset /  
Advarsler / تحذيرات



Descrizione / Description / Description / Beschreibung / Beschrijving /  
Descripción / Descrição / Beskrivning / Описание / Beskrivelse /  
Opis / Kuvaus / Beksrivelse / الوصف



Uso / Use / Utilisation / Gebrauch / Gebruik / Uso / Utilização /  
Användning / Использование / Anvendelse / Użytkowanie /  
Käyttö / Bruk / الإستعمال



Pulizia e manutenzione / Cleaning and care / Nettoyage et entretien /  
Reinigung und Wartung / Reiniging en onderhoud /  
Limpieza y mantenimiento / Limpeza e manutenção /  
Rengöring och underhåll / Чистка и техническое обслуживание /  
Rengøring og vedligeholdelse / Czyszczenie i konserwacja /  
Puhdistus ja hoito / Rengjøring og vedlikehold / التنظيف و الصيانة



Avvertenza di sicurezza / Safety instructions / Consignes de sécurité /  
Sicherheitshinweise / Veiligheidswaarschuwingen /  
Advertencia de seguridad / Advertências de segurança /  
Säkerhetsvarning / Предупреждение о безопасности /  
Sikkerhedsanvisninger / Ostrzeżenie dotyczące bezpieczeństwa /  
Turvallisuuteen liittyvät varoitukset / Sikkerhedsadvarsler / تحذير للسلامة



Informazione / Information / Information / Information / Informatie /  
Información / Informação / Information / Информация / Information /  
Informacja / Tietoa / Informasjon / معلومات



Suggerimento / Advice / Conseil / Empfehlungen / Aanbeveling /  
Sugerencia / Sugestões / Råd / Рекомендация / Forslag / Porada /  
Neuvo / Forslag / اقتراحات

Gentile Cliente, La ringraziamo vivamente per il Suo acquisto. I nostri prodotti sono unici perché uniscono una spiccata ricerca estetica alla progettazione tecnica innovativa. Essi sono coordinati con altri prodotti in gamma e possono costituire elementi d'arredo e di design. Augurandole di apprezzare appieno le funzionalità del Suo elettrodomestico, Le porgiamo i nostri più cordiali saluti.

Dear Customer, Thank you for purchasing one of our appliances. Our products are unique because they combine iconic style with innovative technical solutions. They match perfectly with other products in our range and work equally well as a standalone design objects in your kitchen. We hope you enjoy using your new appliance! Best regards.

Cher client, merci beaucoup pour votre achat. Nos produits sont uniques car ils combinent une forte recherche esthétique avec une conception technique innovante. Ils sont coordonnés avec d'autres produits de la gamme et peuvent constituer des éléments d'ameublement et de design. En espérant que vous pourriez apprécier pleinement votre nouvel appareil électroménager, nous vous adressons nos meilleures salutations.

Sehr geehrter Kunde, wir danken Ihnen herzlichst für den Kauf. Unsere Produkte sind einzigartig, da sich in ihnen eine gewissenhafte Designforschung und eine innovative technische Planung vereinen. Sie sind mit anderen Produkten des Sortiments kombinierbar und stellen ausgefallene Einrichtungs- und Designgegenstände dar. Wir hoffen, dass Sie Ihr neues Haushaltsgerät voll und ganz schätzen werden und verbleiben mit freundlichen Grüßen.

Beste klant, hartelijk dank voor uw aankoop. Onze producten zijn uniek omdat ze esthetiek combineren met innovatief technisch ontwerp. De producten zijn uitstekend te combineren andere producten van het assortiment en kunnen worden gebruikt als meubel- en designelementen. We hopen dat u volop van uw nieuwe huishoudelijke apparaat zult genieten. Met vriendelijke groet

Estimado cliente, le damos las gracias por su compra. Nuestros productos son únicos porque combinan una notable búsqueda estética con un diseño técnico innovador. Se combinan con otros productos de la gama y se pueden utilizar como elementos de decoración y diseño. Le deseamos que pueda apreciar plenamente su nuevo electrodoméstico. Le enviamos nuestros saludos más cordiales.

Prezado cliente, Muito obrigado pela sua compra. Os nossos produtos são únicos porque combinam uma forte busca estética com um desenho técnico inovador. São coordenados com outros produtos da linha e podem constituir elementos de decoração e design. Esperando que possa desfrutar totalmente das funcionalidades do seu eletrodoméstico, enviamos-lhe os nossos melhores cumprimentos.

Bäste kund, vi vill tacka dig för ditt köp. Våra produkter är unika eftersom de kombinerar ett estetiskt nytänkande med innovativ teknik. Våra produkter passar med de andra i samma serie och kan användas som föremål inom heminredningen för att ge en särskild känsla av stil i ditt hem. Vi hoppas att du till fullo kommer att uppskatta funktionerna hos din hushållsmaskin. Med bästa hälsningar.

Уважаемый покупатель! Благодарим Вас за покупку. Наши изделия уникальны, поскольку они сочетают в себе великолепный дизайн и передовые технические решения. Кроме того, они комбинируются с другими изделиями из этой линейки и могут стать стильными элементами интерьера и дизайна. Надеемся, что Вы в полной мере оцените функциональные возможности Вашего бытового прибора. С наилучшими пожеланиями.

Kære Kunde, mange tak for dit køb. Vores produkter er unikke, da de forener æstetisk research og innovativt teknisk design. De passer perfekt sammen med de andre produkter i serien, og kan stå som et enkeltstående møbel af design. Vi håber, at du vil værdsætte din hårde hvidevars funktionalitet, og sender de bedste hilsener.

Szanowny Kliencie, Dziękujemy za Twój zakup. Nasze produkty są wyjątkowe, ponieważ łączą intensywne badania estetyczne z innowacyjnym projektem technicznym. Są one skoordynowane z innymi produktami z asortymentu i mogą stanowić elementy wyposażenia i wystroju. Mamy nadzieję, że będą Państwo mogli w pełni korzystać z funkcjonalności tego urządzenia. Serdecznie pozdrawiamy.

Arvoisa Asiakas, kiitämme sinua hankintasi johdosta. Tuotteemme ovat ainutlaatuisia, koska yhdistyvät esteettisyyss ja innovatiivinen tekninen suunnittelu. Ne sopivat yhteen muiden valikoimaan kuuluvien tuotteiden kanssa toimien samalla sisustus- ja design-tuotteina. Toivomme, että voit nauttia täysin siemauksin kodinkoneesi toiminnoista. Sydämellisin terveisin.

Kjære kunde. Vi takker for at dere valgte å kjøpe et av våre produkter. Våre produkter er unike fordi de forener søken etter estetikk med en nyskapende teknisk design. De koordineres med andre produkter i vårt sortiment og kan ha funksjon som både møbel- og designvare. Vi håper du får fullt utbytte av ditt husholdningsapparat, og sender deg våre beste hilsener.

تحتفظ جهة التصنيع بحقها في إجراء أية تغييرات تراها ضرورية لتحسين منتجاتها دون إخطار مسبق. لذا، تعتبر الرسوم التوضيحية والأوصاف الواردة في هذا الدليل غير ملزمة ولكنها إرشادية فقط.

A

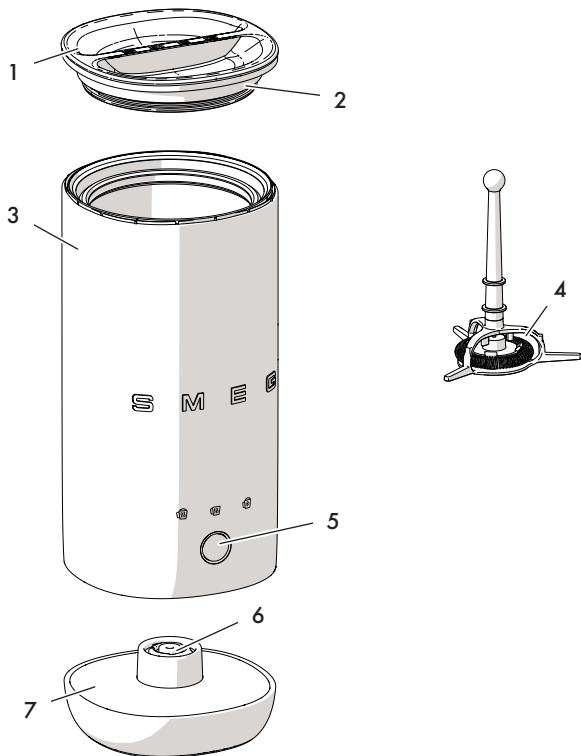

B

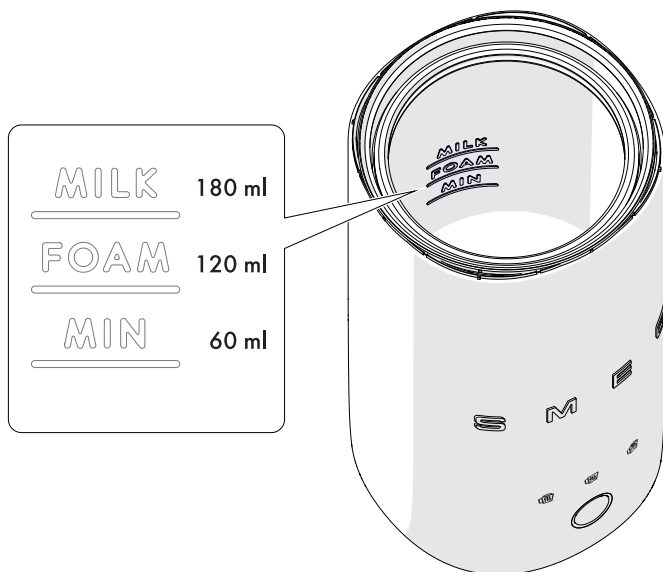

C

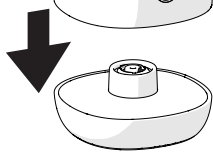
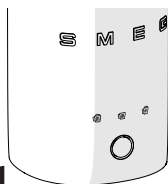
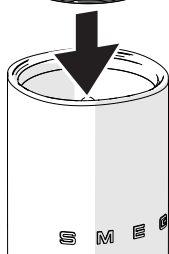
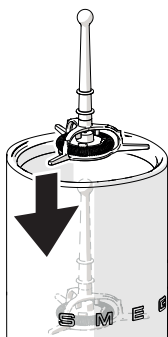
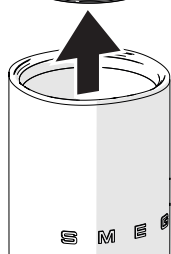

D

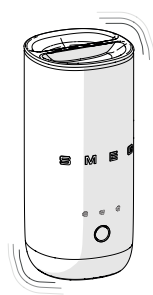
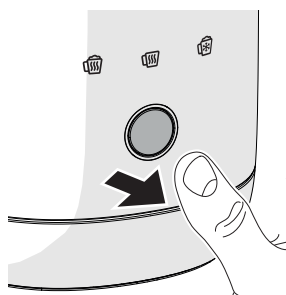



## 1 Instructions

This user manual is an integral part of the appliance and must therefore be kept in its entirety and within the user's reach for the whole working life of the appliance.

### 1.1 Intended use

Failure to respect the safety warnings and read the instruction booklet may result in improper use of the appliance and personal injury.

- Only use the appliance indoors and at a maximum altitude of 2000 metres.
- This appliance is intended for household use and similar applications such as:
  - staff kitchen areas in shops, offices and other working environments
  - bed and breakfast facilities/farm accommodation
  - by guests in hotels, motels and other residential accommodations;
- The appliance is not designed to operate with external timers or with remote-control systems.
- Use the appliance indoors and protected from atmospheric agents.

- This appliance is not intended for use by persons with reduced physical, sensory or mental abilities (including children under the age of 8) unless they are supervised or have been properly instructed on how to use the appliance safely.

### 1.2 General safety instructions

Follow all safety instructions in order to use the appliance safely:

- Read this user manual carefully before using the appliance.
- Do not place the appliance on or near gas burners or electric hot plates that are switched on, inside an oven, or near any heat sources.
- Do not leave the appliance unattended when it is switched on.
- Avoid contact with moving parts during operation.
- Keep hands, hair, clothing and tools away from moving parts during operation to avoid personal injury and/or damage to the appliance.
- Switch off the appliance immediately after use.



## Instructions

- Do not immerse the appliance, power cable or plug in water or any other liquid.
- This appliance has an earth connection for functional purposes only.
- Never attempt to extinguish a fire/flames with water: switch off the appliance, remove the plug from the socket, smother the flames with a fire blanket or other suitable cover.
- Always disconnect the appliance from the power supply before assembling or disassembling components.
- Always unplug the appliance and allow it to cool before cleaning.
- Use only genuine spare parts. The use of spare parts not approved by the manufacturer may result in fire, electric shock or personal injury.
- Do not attempt to modify or repair the appliance: in the event of a malfunction, it must be repaired by a qualified technician or by the technical support.
- The cable is intentionally short to prevent accidents. Do not use an extension cord.
- Do not allow the power cable to come into contact with sharp edges.
- Do not pull the cable to remove the plug from the wall socket.
- Do not use the appliance when the power cord or the plug is damaged or when the appliance has been dropped or is damaged in any manner.
- If the power cable is damaged, contact technical support for replacement.
- Children must never play with the appliance. Keep the appliance and its power cable out of the reach of children.
- The appliance must only be used with the power base provided.
- To avoid damage, do not allow liquids to enter the socket.
- The surface of the heating element may remain hot after use.
- Do not allow children to clean or maintain the appliance without supervision



## 1.3 Caution

- Do not use the milk frother without the lid.
- Check that the lid is properly closed before switching on the milk frother.
- Do not overfill the milk frother.
- Do not use the milk frother with parts or accessories from other manufacturers.
- Only place the milk frother on flat, dry surfaces.
- Do not use the milk frother when empty to avoid permanent damage to the whisk.
- Do not use the milk frother as a storage container. Keep the milk frother empty before and after use.
- Do not place metal objects such as knives, forks and spoons on the appliance during use.
- For instructions on how to clean the appliance properly, please refer to section "4 Cleaning and maintenance".

## 1.4 Connecting the appliance

Make sure that the mains voltage and frequency match those specified on the data plate on the underside of the appliance.

In case of incompatibility between the socket and the plug of the appliance, contact the technical support service for replacement.

## 1.5 Manufacturer liability

The manufacturer declines any liability for damage to persons or property caused by:

- Use of the appliance other than the one envisaged.
- Not having read the user manual.
- Tampering with any part of the appliance.
- Use of non-original spare parts
- Failure to comply with the safety instructions



**Please keep this instruction booklet in a safe place. If the appliance is passed on to another person, please also give them this instruction booklet.**

These instructions can be downloaded from the Smeg website "[www.smeg.com](http://www.smeg.com)".



## 1.6 Disposal



Appliances marked with this symbol are subject to the requirements of European Directive 2012/19/EU.

- All waste electrical and electronic appliances must be disposed of separately from household waste and taken to an authorised waste disposal facility. Correct disposal of this appliance will help protect the environment and human health. For further information on how to dispose of the used appliance, please contact your local authority waste disposal department or the shop where you purchased it.

## 2 Appliance description (Fig. A)

- 1) Lid
- 2) Seal
- 3) Milk frother
- 4) Whisk
- 5) Function selection and start button
- 6) Connector
- 7) Base



The accessories intended to come into contact with foodstuffs are made of materials that comply with the provisions of current legislation.

### 2.1 Identification plate

The identification plate bears the technical data, serial number and brand name of the appliance.

Do not remove the identification plate for any reason.



## 2.2 Level indicators (Fig. B)

The level indicators are located inside the container and in the notches on the whisk.

NE

Symbol	Description
	<p>Maximum milk level for "hot milk function".</p>
	<p>Maximum milk level for "hot/cold frothing function".</p>
	<p>Minimum milk level.</p>



## Use

### 3 Use

#### 3.1 Before first use



##### **Danger of electrocution**

Plug the appliance into a suitable earthed socket.

- Do not remove the earth prong.
- Do not use an adapter.
- Do not use an extension cord.
- Failure to follow these instructions could result in death, fire, or electric shock.

Carry out a pre-cleaning cycle before using the appliance:

- 1) Remove the lid (1) from the milk frother (3).
- 2) Insert the whisk (4) into the milk frother (3).
- 3) Fill the milk frother (3) with fresh, still drinking water up to the level mark (FOAM=120ml).
- 4) Place the lid (1) on the milk frother (3).
- 5) Place the milk frother (3) correctly on its base (7).
- 6) Press the button (5) and wait 3 seconds for the cleaning cycle to start.
- 7) The appliance will beep three times to signal the end of the cleaning cycle.
- 8) Remove the milk frother (3) from the base (7) and empty it.
- 9) Wash and dry thoroughly (see "4.1 Cleaning the components").



##### **Risk of accidental start**

Make sure the milk frother is unplugged before fitting or removing the whisk.



### 3.2 Heat or froth the milk (Fig. C and D)



Do not use the appliance without liquid. Starting the appliance without liquid can damage the jug.

Always fill to the MIN level and never higher than the MILK level, both of which are indicated inside the milk frother.



For an ideal hot milk froth, use cold (4-8°C) whole milk (pasteurised or UHT) from the fridge. Avoid using milk at ambient temperature.

- 1) Remove the lid (1) from the milk frother (3).
- 2) Insert the whisk (4) into the milk frother (3).



Do not use the milk frother without the whisk attached.

- 3) Pour cold milk into the milk frother (3). Observe the level indicators inside the milk frother.
- 4) Place the lid (1) on the milk frother (3).
- 5) Place the milk frother (3) correctly on its base (7).



The appliance is now switched on and ready for use.

- 6) Press the button (5) to select one of the three functions available:



## Use

- **Hot foam function (8)**

Press the button (5) once; the "hot foam function" LED lights up.

- **Hot milk function (9)**

Press the button (5) twice; the "hot milk function" LED lights up.

- **Cold foam function (10)**

Press the button (5) three times; the "cold foam function" LED lights up.



Press the button (5) again to switch off all LEDs.

- 7) To activate the required function, select the mode and wait 3 seconds. The function will start automatically.



You can stop the cycle before the set time by pressing the button (5).

- 8) The end of the cycle is indicated by three beeps and the LED of the selected function goes out.
- 9) Remove the milk frother (3) from the base (7).
- 10) Remove the lid (1) and pour the hot or frothed milk into the cup.



After use, the appliance automatically switches to standby mode after 1 minute of inactivity.  
Standby power consumption: 0.1 W (in accordance with the ERP directive).



## 4 Cleaning and maintenance



### Improper use. Danger of electrocution

- Unplug the milk frother before cleaning it.
- Never immerse the base in water or other liquids.



### Improper use. Risk of damage to surfaces.

- Do not use steam jets to clean the appliance.
- Do not use detergents containing chlorine, ammonia or bleach on parts with metal surfaces (e.g. anodised, nickel-plated, chrome-plated).
- Do not use abrasive or corrosive detergents (e.g. powder products, stain removers and metallic scourers).
- Do not use rough or abrasive materials or sharp metal scrapers.

## 4.1 Cleaning the components

To make cleaning easier, it is recommended that the components are cleaned regularly after each use after they have cooled down.

		
Lid	✓	✓
Milk frother	✓	x
Whisk	✓	✓
Base	✓	x



Make sure that the components are completely dry before putting them back into the milk frother.



## What to do if...

Problem	Cause	Solution
	Appliance not connected to the mains.	Make sure that the power cable is properly plugged into the wall socket.
	The appliance is connected to multiple sockets or a power strip.	Plug the appliance directly into a power socket.
<b>The milk frother does not start</b>	No power.	Make sure that the main circuit breaker is switched on.
	Milk frother not inserted properly.	Check that the milk frother is correctly placed on the base and that there are no foreign objects between the base and the milk frother that could prevent it from working correctly.
<b>Milk frother does not froth milk</b>	There is no whisk in the milk frother or it is not correctly assembled/installed.	Check that the whisk is present, assembled and correctly fitted in the milk frother.

# What to do if...



2

Problem	Cause	Solution
<b>Poor quality milk froth</b>	Dirty milk frother or whisk.	Make sure the milk frother and whisk are clean.
	Incorrect amount of milk.	Check that the correct amount of milk has been inserted and that it is at the correct level.
	Unsuitable milk.	It is recommended to use cold milk from the fridge (4-8°C) to obtain an optimal hot froth.
	Too long a period between the end of preparation and consumption.	Pour the preparation into the cup as soon as it is ready and consume it immediately.
<b>Milk leaks from the frother during use</b>	There may be too much milk.	Respect the level indicator.
<b>Milk too hot or burnt</b>	Incorrect amount of milk.	Make sure you have not used less than the minimum amount of milk (60 ml).



## What to do if...

Problem	Cause	Solution
<b>The milk frother is noisy</b>		Make sure you have inserted the whisk correctly.
	Components are not installed correctly.	Make sure the lid is correctly fitted.
		Make sure the appliance is on a stable surface.
	Foreign objects present.	Check that there are no foreign objects inside the milk frother and between the base and the milk frother that could prevent it from working properly.
<b>Milk frother stops during operation</b>	The milk frother is too hot.	Rinse the milk frother with cold water and refill with cold milk.
	Milk is too hot.	Do not reuse pre-heated milk. Use cold milk.



If the problem persists, or for other faults, contact your local service centre.



Il costruttore si riserva di apportare senza preavviso tutte le modifiche che riterrà utili al miglioramento dei propri prodotti. Le illustrazioni e le descrizioni contenute in questo manuale non sono quindi impegnative ed hanno solo valore indicativo.

The manufacturer reserves the right to make any changes deemed necessary for the improvement of its products without prior notice. The illustrations and descriptions contained in this manual are therefore not binding and are merely indicative.

Le fabricant se réserve la faculté d'apporter, sans préavis, toutes les modifications qu'il jugera utiles pour l'amélioration de ses produits. Les illustrations et les descriptions figurant dans ce manuel ne sont pas contraignantes et n'ont qu'une valeur indicative.

Der Hersteller behält sich vor, ohne vorherige Benachrichtigung alle Änderungen vorzunehmen, die er zur Verbesserung seiner Produkte für nützlich erachtet. Die in diesem Handbuch enthaltenen Illustrationen und Beschreibungen sind daher unverbindlich und dienen nur zur Veranschaulichung.

De fabrikant behoudt zich het recht voor zonder waarschuwing alle wijzigingen aan te brengen die hij nodig acht om zijn producten te verbeteren. De afbeeldingen en de beschrijvingen die aanwezig zijn in deze handleiding zijn niet bindend, en hebben enkel een aanduidende waarde.

El fabricante se reserva el derecho a aportar sin aviso previo todas las modificaciones que considere útiles para la mejora de sus propios productos. Las ilustraciones y las descripciones contenidas en este manual no son vinculantes y tienen solo valor indicativo.

O fabricante reserva-se o direito de efetuar, sem aviso prévio, qualquer modificação que vise o melhoramento dos respetivos produtos. As ilustrações e descrições contidas neste manual não são, por isso, vinculativas e possuem apenas valor indicativo.

Tillverkaren förbehåller sig rätten att genomföra alla de ändringar som anses nödvändiga för att förbättra de egna produkterna utan att meddela detta i förväg. De illustrationer och beskrivningar som finns i aktuell manual är därmed inte bindande utan endast indikativa.

Для улучшения выпускаемой продукции изготовитель оставляет за собой право вносить без предварительного предупреждения любые изменения, которые он сочтет целесообразными. Рисунки и описания, содержащиеся в данном руководстве, не являются обязывающими и носят ознакомительный характер.

Fabrikanten forbeholder sig retten til, uden varsel, at udføre alle de ændringer, der vurderes nyttige for at forbedre egne produkter. Tegningerne og beskrivelserne i denne manual er derfor kun vejledende og ikke bindende.

Producent zastrzega sobie prawo do nanoszenia, bez uprzedniego powiadomienia, wszelkich zmian, które uzna za stosowne w celu ulepszenia swoich produktów. Rysunki i opisy zawarte w niniejszej instrukcji nie są zobowiązujące i mają jedynie charakter orientacyjny.

Valmistaja pidättää itsellään oikeuden tehdä ohjeisiin mielestään tarpeellisia muutoksia ilman ennakoilmoitusta. Tässä oppaassa olevat kuvat ja piirrookset eivät näin ollen ole sitovia, vaan ne annetaan vain viitteellisessä mielessä.

Produsenten forbeholder seg rett til å foreta endringer på sine produkter grunnet tekniske fremskritt, uten forutgående varsel. Illustrasjonene og beskrivelsene i denne bruksanvisningen er derfor ikke bindende og skal kun betraktes som retningsgivende.

عميلنا العزيز، شكراً لك على شراء أحد أجهزةتنا. تعد منتجاتنا فريدة لأنها تجمع بين الأسلوب المميز والحلول التقنية المبتكرة. وهي تتناسب تماماً مع المنتجات الأخرى في مجموعتنا وتعمل بنفس القدر كتصميمات قائمة بذاتها في مطبخك. نأمل أن تستمتع باستخدام هذا الجهاز الجديد! وتفضلوا بقبول وافر الاحترام والتقدير.