

WOLSTEAD

Dulce

Ice Cream Machine with Compressor 2L

Owner's Manual



IMPORTANT:

This instruction manual contains important information necessary for the proper assembly and safe use of the appliance.

Read and follow all warnings and instructions before assembling and using the appliance. Keep this manual for future reference.

SPECIFICATIONS

Model: 620826

Capacity: 2 Litres

Voltage: AC 220 to 240V/50Hz

Power consumption: 180W

Max overall dimensions: 425mm (L) X 285mm (W) X262mm (H)

PRODUCT FEATURES

1. Makes ice cream in 60 minutes
2. Fully automatic ice cream maker with a built-in compressor
3. Detachable stainless steel two litre bowl
4. Customise your own flavours and make ice cream, gelato, sorbet and yoghurt
5. Easy to use LCD touchscreen display
6. Strong stirring force for creamier ice cream
7. Monitor status through the transparent cover
8. No pre-freezing required
9. Parts are detachable and easy to clean

SAFETY PRECAUTIONS

When using this electrical appliance, basic safety precautions should always be followed to reduce the risk of fire, electric shock, and/or injury, including the following:

1. Read all instructions before using.
2. Ensure the voltage is compliant with the voltage range stated on the rating label, and ensure the earthing of the socket is in good condition.
3. If the supply cord is damaged, it must be replaced by the manufacturer or its service agent or a similarly qualified person in order to avoid a hazard.
4. This appliance is not intended for use by persons (including children) with reduced physical, sensory or mental capabilities, or lack of experience and knowledge, unless they have been given supervision or instruction concerning use of the appliance by a person responsible for their safety.
5. Children should be supervised to ensure that they do not play with the appliance.
6. This appliance is intended to be used in household and similar applications such as:
 - Staff kitchen areas in shops, offices and other working environments.
 - Farmhouses.
 - By clients in hotels, motels and other residential type environments.
 - By bed and breakfast type environments.
7. Unplug the appliance after using and before cleaning.
8. Do not upend this product or incline it over a 45° angle.

9. To protect against risk of electric shock, do not place cord, plug or the base of the appliance in water or any other liquid.
10. Avoid contact with moving parts. Keep hands, hair, clothing, as well as spatulas and other utensils away from the unit during operation to reduce the risk of injury and/or damage to the appliance.
11. Keep the appliance 8cm from other objects to ensure heat is easily released.
12. Do not use accessories which are not recommended by the manufacturer.
13. Do not use the appliance close to flames, hot plates or stoves.
14. Do not turn the power on and off again repeatedly (ensure five minute intervals between switching on and off) to avoid damaging the compressor.
15. When taking out the ice cream, avoid knocking the bowl or edge of the barrel to protect it from damage.
16. Do not switch on the power before installing the bowl or mixing paddle.
17. Do not pre-freeze ingredients as it can cause the mixing paddle to block.
18. Do not remove the mixing paddle when the appliance is on and churning.
19. Do not use outdoors.
20. Never clean with scouring powders or hard implements.

Warning

- Do not obstruct ventilation openings.
- Do not use mechanical devices or other means to accelerate the defrosting process, other than those recommended by the manufacturer.
- Do not damage the refrigerant circuit.
- When positioning the appliance, ensure the cord is not trapped or damaged.
- Do not locate multiple portable socket outlets or portable power supplies at the rear of the appliance.
- When disposing of the appliance, do so only at an authorised waste disposal centre.
- Do not expose yourself to flame.

Before first use

Avoid tilting the machine more than 45°. If the machine has been tilted more than 45° during transport, allow it to stand upright for at least four hours before it is connected to the power.

Caution: Risk of fire



The refrigerant isobutene (R600a) is contained within the refrigerant circuit of the appliance, a natural gas with a high level of environmental compatibility, which is nevertheless flammable. During transportation and installation of the appliance, ensure that none of the components of the refrigerant circuit become damaged. The refrigerant (R600a) is flammable.

If the refrigerant circuit is damaged:

- Avoid open flames and sources of ignition.
- Thoroughly ventilate the room in which the appliance is situated.

GET TO KNOW THE WOLSTEAD DULCE ICE CREAM MAKER WITH COMPRESSOR

1. Structure

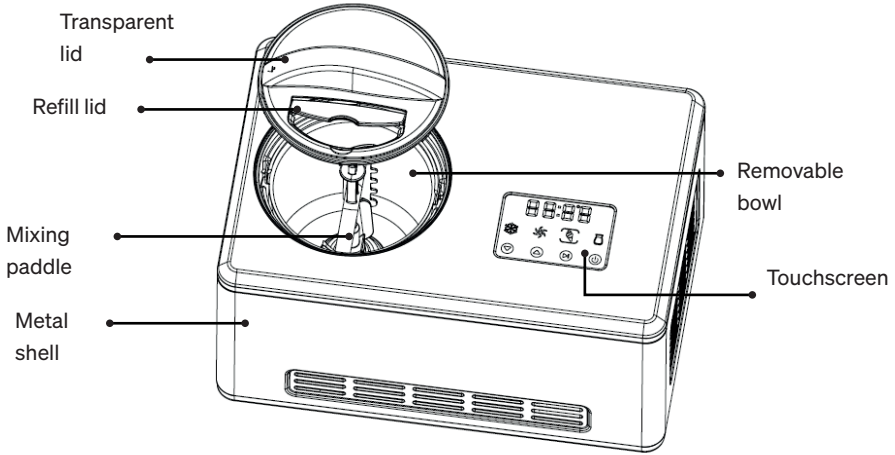

2. Control panel

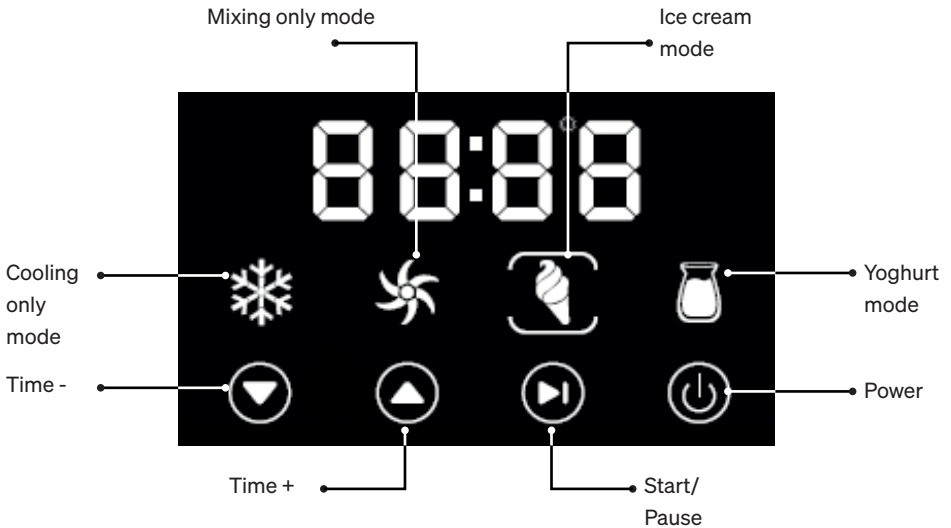

OPERATING INSTRUCTIONS

1. **Connect the power supply** and plug the power cord into a suitable powerpoint. The system will beep once and the POWER button will light up and flash. This is the power-on state.

2. Using the touchscreen

Power button: Press the POWER button to enter the mode selection interface where you can choose between the four available modes by pressing one of the four icons (cooling only mode, mixing only mode, ice cream mode, or yoghurt mode). The machine defaults to ice cream mode at 60 minutes when it is first turned on. The upper and lower brackets will appear around the icon you've chosen to indicate that it's been selected as shown in the image above (ice cream mode). To turn the appliance off, press the POWER button again.



To select your desired mode, touch the relevant icon on the screen and then adjust the time accordingly. Once you've selected the desired mode, tap the START/PAUSE button, production will start and the icon of the chosen mode will turn green.

Time: To set the desired production time, press the up and down arrows to add and subtract time.

TIME+ button: Touch the up arrow TIME+ once and the time will increase by one minute. If you hold the button TIME+ for over two seconds, the time will set to mode and a maximum of 24 hours in the yoghurt mode.

TIME- button: Touch button TIME- once and the time will decrease by one minute. If you hold the button TIME- for over two seconds, the time will decrease rapidly.

Ice cream button: The default time is 60 minutes.

Yoghurt button: The default time is eight hours.

START/PAUSE button: After choosing the mode and time, touch this button to start the working mode. The function has started once the START/PAUSE button has stopped flashing. Touching START/PAUSE again will pause the machine and the button will flash.

Caution: Once you have selected your desired mode and pressed START/PAUSE, the display will be locked. To unlock it, press START/PAUSE again.

Note: If you want to switch to a different mode or change the time after you've pressed START, simply tap the START/PAUSE button once, then tap it again and hold it for more than two seconds. You can then choose the mode and time you want to change to and then press START/PAUSE again to start the new mode.

3. Ice cream mode (for making ice cream)

- a. The default production mode is 60 minutes. If you need to adjust the working time, press the up and down arrow TIME buttons. Press the buttons once to change by one minute, and long press for two seconds to change quickly, up to a maximum of 60 minutes.
- b. After setting the time, press the START/PAUSE button to start making ice cream. The ice cream icon will turn green and the timer will start counting down. In this mode, if you press the START/PAUSE button, the machine will pause and the START/PAUSE button will flash continuously. Press START/PAUSE again to restart.

4. Cooling only mode (used for pre-cooling ingredients)

- a. In the cooling only mode, the default working time is 30 minutes. If you need to adjust the working time, press the up and down arrow TIME buttons. Press the button once to change by one minute, and long press it for two seconds to change quickly, up to 60 minutes.
- b. After setting the time, press the START/PAUSE button to start refrigeration. The cooling only icon will turn green and the timer will start counting down. In this mode, if you press the START/PAUSE button, the machine will pause and the START/PAUSE button will flash continuously. Press START/PAUSE again to restart.

5. Mixing only mode (for mixing in additional ingredients such as choc chips)

- a. In the mixing only mode, the default working time is 10 minutes. If you need to adjust the working time, press the up and down arrow TIME buttons. Press the button once to change for one minute, and long press it for two seconds to change quickly, up to 60 minutes.
- b. After setting the time, press the START/PAUSE button to start mixing only mode. The mixing only icon will turn green and the timer will start counting down. In this mode, if you press the START/PAUSE button, the machine will pause and the START/PAUSE button will flash continuously. Press START/PAUSE again to restart.

6. Yoghurt mode (for making yoghurt):

- a. In the yoghurt mode, the initial default working time is eight hours. You can increase the time to a maximum of 24 hours and decrease to a minimum of four hours.
Note: The yoghurt mode has a memory function. After first use, the machine will then default to the same working time that was chosen the last time you ran the yoghurt mode.
- b. If you need to adjust the working time, press the up and down arrow TIME buttons. Press the button once to change for one hour, and long press it for two seconds to change quickly, up to 24 hours and down to four hours.
- c. After setting the time, press the START/PAUSE button to start refrigeration. The yoghurt icon will turn green and the timer will continue to flash. In this mode, if you press the START/PAUSE button, the machine will pause and the START/PAUSE button will flash continuously. Press START/PAUSE again to restart.
- d. After the machine completes the yoghurt mode production, the machine automatically enters the refrigerating mode, the screen displays 'COOL' and the compressor and fan motor start to work for 15 minutes. After 15 minutes, when the temperature sensor detects that the temperature is higher than 9°C, the compressor and fan motor will start running for four minutes. If there is no other operation selected, the machine will remain in the refrigerated mode without shutting down.
- e. NOTE: In the yoghurt mode, the appliance heats up to a maximum of 45°C.

ADDITIONAL FUNCTIONS

1. Keep cool function

When the ice cream function has completed, it will automatically enter the keep cool function. The keep cool time is one hour. After one hour, the machine will enter the standby state.

2. Heat preservation function

After the machine finishes the ice cream mode, it will automatically enter 'heat preservation function' for 60 minutes, during which the motor cools down. At the end of 60 minutes, the appliance will beep three times to signal the end of heat preservation mode and the power will return to the power-on state. To skip this function and continue making ice cream, turn the appliance off, then back on again.

Warning: It is only recommended that you ever run the ice cream function for two cycles in a row, running it repeatedly for more than two cycles risks overheating the motor.

3. Motor self-protection function

The motor self-protection safety feature may activate under heavy loads or if the unit has been running for an excessively long period of time. As the production time becomes longer and the ice cream becomes harder, the stirring motor can become blocked. At this time, the temperature controller of the motor will monitor the temperature and automatically stop the motor to protect it from damage.

4. Compressor self-protection function

The Wolstead Dulce Ice Cream Maker with Compressor is equipped with a safety feature called 'compressor self-protection mode' that automatically activates for three minutes after the compressor finishes ice cream mode or cooling only mode. Once the three minutes have passed, you can select ice cream or cooling only mode again. Unplugging the appliance and plugging it back in will bypass the three minute safety feature, but to preserve the longevity of the product, this is not recommended.

GETTING STARTED

Clean the machine

Before first use, thoroughly clean all parts of the appliance that will make contact with ingredients, including the bowl, mixing paddle and transparent lid. Before cleaning, ensure the plug is disconnected from the powerpoint. When in use, keep the machine flat on a level surface to ensure that the compressor of the machine is working properly.

Controlling the volume of ingredients

To avoid overflow and waste, please ensure the bowl is filled to no less than 500ml and no more than 1.2 litres (60% of the capacity of the removable bowl). Refer to the measurement markings on the bowl.

Step 1. Pour the recipe ingredients into the bowl, then mix to combine.

Note: This machine has a built-in compressor that freezes ingredients as you go, so you don't need to freeze the bowl for hours in a freezer in advance, but we have found it can help. You can also pre-chill the bowl by running the machine for five to 10 minutes before pouring in the ingredients.

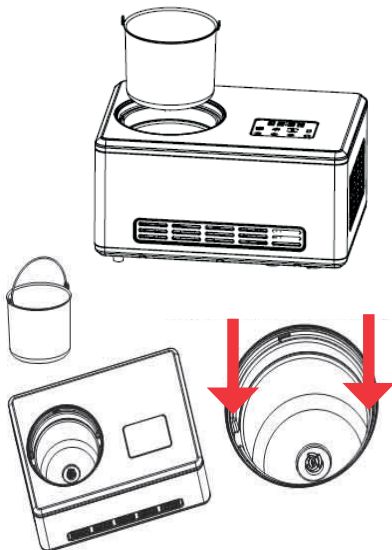
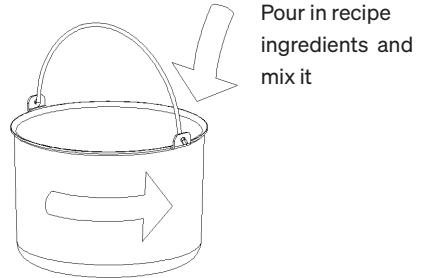

Step 2. Insert the bowl into the ice cream machine. Both ends of the bowl handle should be aligned with the groove of the upper cover.

The two ears of the loading bucket should face the two notches on the top cover, as indicated by the arrow.

Step 3. If using the ice cream mode, install the mixing paddle, if using the yoghurt mode, then remove the mixing paddle. Then put the transparent lid onto the machine and lock it anticlockwise (see right picture).

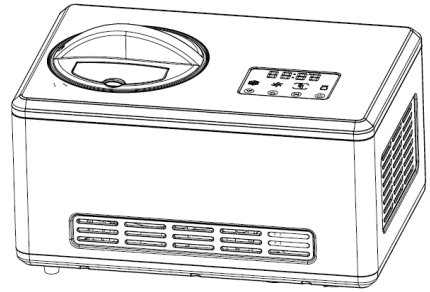

Step 4. Touch the POWER button to turn the machine on.

Step 5. To select your desired mode, touch the relevant icon on the screen and then adjust the time accordingly. Once you've selected the desired mode, tap the START/PAUSE button and production will start.

Step 6. You can add ingredients by opening the refill cover (see below picture).

Open the refilling lid, and add the ingredients

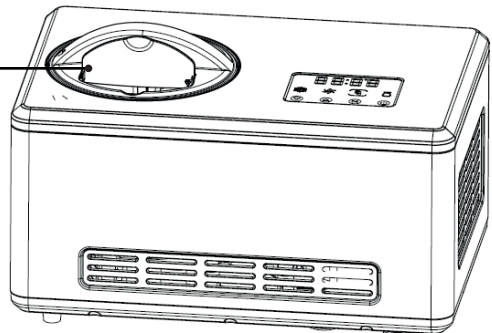

Step 7. After operation is complete, turn off the machine, then pull the removable bowl out.

HOW TO STORE ICE CREAM

Remove finished ice cream and store it in an airtight container. Use a plastic scoop or a wooden spoon to scoop the ice cream out of the stainless steel bowl, don't use a metal scoop as you will scratch the inside of the bowl.

MAINTENANCE

Caution: The plug must be removed before cleaning to avoid electric shock.

1. Take out the mixing paddle, wipe it with a damp cloth.
2. Take out the bowl, clean it with a damp soft cloth.
3. Wipe the transparent lid with a damp cloth.
4. Remove the dirt on the body or other places with a damp cloth
5. Do not immerse the appliance in water or any other liquid
6. Dry thoroughly with a dry cloth, then return the component to the home position.

TROUBLESHOOTING

No.	Problem	Reason	Resolution
1	The loading bowl is hard to remove when the ice cream mode finishes.	There are water drops between the refrigeration barrel and the loading bowl that are not wiped clean, resulting in freezing.	Wait three to eight minutes before taking out the loading bowl.
2	The transparent lid is lifted to the mixing paddle, and it cannot be closed properly.	The mixing paddle is not in place. Pay attention to the alignment of the convex hull at the bottom.	Put the mixing paddle in place and rotate the transparent cover closed.
3	The loading bowl cannot be placed in the cooling compartment.	Deformation caused by improper use of the loading bowl.	Contact Kitchen Warehouse Customer Service to purchase a new loading bowl.
4	At the beginning of making ice cream, the mixing paddle seriously scratched or jammed.	Deformation caused by improper use of the loading bowl.	Contact Kitchen Warehouse Customer Service to purchase a new loading bowl.

RECIPE TIPS

The following recipes and tips are designed to help you get started with your Wolstead Pro Dulce Ice Cream Maker.

- For optimum consistency, chill all mixtures for a minimum of two hours, or up to three days. Always whisk the mixture after chilling to be sure all ingredients are well combined. While chilling the mixture is not required, this step will prevent any ice or fat crystals from forming during the freezing process as resting it in a chilled environment helps bind the ingredients together.
- Some recipes use cooked ingredients. For best results, the mixture should be chilled overnight before using. Or chill the recipe over an ice bath, until it is completely cooled, before using. To make an ice bath, fill a large container with ice and water. Place a saucepan or other container into the ice bath. Cool the cooked ingredients completely.
- You can substitute low fat creams and/or milk (reduced fat or low fat) for heavy cream and whole milk used in many recipes. However, keep in mind that the higher the fat content, the richer and creamier the result. Using low fat substitutes may change the taste, consistency, and texture of the dessert. When substituting, be sure to use the same volume of the substitute as you would have used of the original item. For example, if the recipe calls for two cups of cream, use a total of two cups of the substitute (such as one cup cream, one cup whole milk).
- When making sorbet, be sure to test the ripeness and sweetness of the fruit before you use it. The freezing process reduces the sweetness of the fruit so that it will taste less sweet than the recipe mixture. If the fruit tastes tart, add additional sugar to the recipe. If the fruit is very ripe or sweet, reduce the amount of sugar in the recipe.
- When adding ingredients such as chips and nuts, add them roughly five minutes before the freezing process is complete. You want it to still be soft enough to fully incorporate into the frozen mixture.

RECIPES

Vanilla Ice Cream

Serves: 8 people

Prep time: 20 minutes

Cooking time: 60 minutes

Ingredients

- 600 ml whole milk
- 300 ml single cream
- 2 tsp good quality vanilla bean paste
- 8 egg yolks
- 200g caster sugar

Method

1. Pour the milk and the cream into a saucepan. Add the vanilla paste into the milk and bring to a slow boil. Do not over boil.
2. In a separate bowl, whisk the yolks and the sugar to a pale and smooth consistency. Gradually pour in 100ml of the warmed milk mixture, whisking continuously so the mixture doesn't curdle. Return everything to the saucepan.
3. Cook gently until the liquid thickens to a custard. This will take approx 15 minutes. Keep stirring so the bottom doesn't burn.
4. Pour the custard into a bowl, cover and refrigerate for at least an hour and up to 12 hours (makes 800 ml of custard).
5. Set the ice cream machine to cooling only mode 10 minutes before you are ready to pour the mixture into the ice cream machine bowl, then add the mixture to the bowl, select the ice cream mode and set the timer to 60 minutes.
6. When the ice cream is complete it will be smooth but still a little soft. It's best to place ice cream in a storage container in the freezer for an hour or so before use.

Raspberry Sorbet

Serves: 6 people

Prep time: 10 minutes

Cooking time: 40 minutes

Ingredients

- 3 cups water
- 1 ½ cup caster sugar
- 1 pinch of salt
- 6 cups frozen raspberries, thawed
- 2 limes, juiced

Method

1. Prepare a simple syrup with the water and sugar by combining both in a medium saucepan set over medium to low heat. Heat mixture until the sugar is fully dissolved. Once the simple syrup is ready, add the salt, lime juice and the raspberries.
2. Using a blender, blend the mixture until smooth. Strain half of the mixture through a fine mesh strainer to remove the seeds. Use a spatula to aid in passing the purée through the strainer. Remove seeds and repeat with the second half. Cover and refrigerate for 2 to 3 hours, or overnight.
3. Set the ice cream machine to cooling only mode 10 minutes before you are ready to pour the mixture into the ice cream machine bowl, then add the mixture to the bowl, select the ice cream mode and set the timer to 60 minutes. If a firmer consistency is desired, transfer the sorbet to a container and place in the freezer for about 2 hours. Remove from the freezer about 15 minutes before serving.

Fresh Homemade Yoghurt

Serves: 12 servings

Prep time: 30 minutes

Cooking time: 8 to 10 hours

Ingredients

- 75g natural yoghurt (not sweetened with sugar or fruit)
- 1.5L full fat milk

Method

1. In a saucepan, heat milk to 90°C and then cool to 40°C. Add yoghurt to the milk and stir thoroughly to mix.
2. Press the POWER button to start the machine then select the YOGHURT MODE.
3. The timer will automatically default to 8 hours. This is a good amount of time to process a smooth yoghurt. Add on an hour or two for a firmer set yoghurt.
4. Add the warm milk mixture to the bowl and press the START button to start the cooking process.
5. Once the cooking process is complete the machine will beep.
6. Place in yoghurt jars and refrigerate or use to make frozen yoghurt in the machine.

WARRANTY

Get in touch with Customer Service

If you experience any issues with your Wolstead Dulce Ice Cream Maker with Compressor 2L, get in touch with our Customer Service team by email at customerservice@kitchenwarehouse.com, au or by phone on 1800 332 934 between the hours of 9am and 7pm (AEST) Monday to Friday. Alternatively you can use the Live Chat function on our website by visiting www.kitchenwarehouse.com.au/contact-us

90 day money back guarantee

We promise you a full refund within 90 days if your Wolstead product does not fulfil your expectations. This guarantee applies to qualified purchases of all Wolstead branded products from participating stockists online and in-store from eligible delivery locations. The qualified product must be returned within 90 days from the date of purchase. We shall issue a full refund when the customer presents proof of purchase. We shall issue a store credit when proof of purchase is unavailable. The product packaging is not required to avail of the refund. The amount refunded will be the price of the products in the currency shown on the proof of purchase.

Exclusions

This warranty does not apply if proper care and/or usage instructions are not followed. This warranty does not cover scratches, stains, discoloration or damage caused by misuse.

How to claim

If a fault/defect is identified cease using the Product immediately. To make a claim on this guarantee, take the Product, proof of purchase and full details of the alleged defect to any Kitchen Warehouse store.

Limitations

We make no express warranties or representations other than as set out in this guarantee. The replacement of the Product or the refund of the purchase price is the absolute limit of our liability under this guarantee.

Warranty

Our goods come with guarantees that cannot be excluded under the Australian Consumer Law. You are entitled to a replacement or refund for a major failure and for compensation for any other reasonably foreseeable loss or damage. You are also entitled to have the goods repaired or replaced if the goods fail to be of acceptable quality and the failure does not amount to a major failure.

The benefits of this warranty are in addition to any rights and remedies imposed by Australian State and Federal legislation that cannot be excluded. Nothing in this warranty excludes, restricts or modifies any State or Federal legislation applicable to the supply of goods which cannot be so excluded, restricted or modified.

Guarantee

We warrant that, subject to the exclusions and limitations below, the Product will be free from defects in materials and workmanship under normal domestic household use for the 12 month warranty period. The warranty period commences on the date of sale by the original retailer to the original purchaser. The warranty applies only while the Product is owned by the original purchaser.

Use of the Product in a commercial capacity will void this warranty. If a defect appears in the Product before the end of the warranty period and we find the Product to be defective in materials or workmanship, we will replace the Product with a product comparable in quality and value.

We reserve the right to change or discontinue our product ranges at any time without notice and without liability.

WOLSTEAD

Distributed by Kitchen Warehouse.

Wolstead is a registered trademark of Kitchen Warehouse Pty Ltd. The printed material appearing in this document and related packaging is protected by copyright.

Kitchen Warehouse Pty Ltd
1 Pensioner Guard Road
North Fremantle, WA, 6159
www.kitchenwarehouse.com.au
1800 332 934
customerservice@kitchenwarehouse.com.au