

# WOLSTEAD

## Instant Hot Water Dispenser 2.5L

Owner's Manual



### **IMPORTANT:**

Read and follow all warnings and instructions before assembly and use.  
Keep this manual for future reference.

## SPECIFICATIONS

- Model: KT3288-E7 / 678894
- Volume: 2.5 litres
- Rated: 220-240V, 2000-2400W
- Frequency: 50/60Hz

## PRODUCT FEATURES

The Wolstead Instant Hot Water Dispenser delivers boiling water in under 10 seconds, no kettle, no waiting! Plus, it only heats and dispenses the amount you need, saving time and energy, making it an efficient, eco-friendly choice.

- Seven adjustable temperatures
- Choose from five water volume settings: Continuous flow, 100mL, 200mL, 300mL, or 400mL, for precise pouring every time
- Includes a child safety lock
- Large capacity 2.5 litre water tank
- Removable water tank and drip tray for easy cleaning
- LCD touchscreen for quick and easy operation

## SAFETY PRECAUTIONS

When using this electrical appliance, basic safety precautions should always be followed to reduce the risk of fire, electric shock, and/or injury, including the following:

1. Read all instructions before using.
2. Ensure the voltage is compliant with the voltage range stated on the rating label.
3. If the electrical cord is damaged, it must be replaced by the manufacturer or its service agent or a similarly qualified person in order to avoid a hazard.
4. This appliance is not intended for use by persons (including children) with reduced physical, sensory or mental capabilities, or lack of experience and knowledge, unless they have been given supervision or instruction concerning use of the appliance by a person responsible for their safety.
5. Children should be supervised to ensure that they do not play with the appliance.
6. This appliance is intended to be used in household and similar applications such as:
  - a. Staff kitchen areas in shops, offices and other working environments.
  - b. Farmhouses.
  - c. By clients in hotels, motels and other residential type environments.
  - d. By bed and breakfast type environments.
7. To protect against risk of electric shock, do not place cord, plug or the base of the appliance in water or any other liquid.

8. Unplug the appliance after using, before cleaning and storing.
9. Keep the appliance 30cm from other objects and the wall to ensure heat is easily released.
10. Do not use attachments or accessories which are not recommended by the manufacturer.
11. To avoid danger, the product is only suitable for the purpose indicated in this manual. Do not use this product or any part for other purposes. If it is operated incorrectly, it may cause injury.
12. Always use the appliance on a firm and stable surface.
13. Do not use the appliance outdoors.
14. Do not touch the water spout when the appliance is operating as it may be hot.
15. To avoid scalding or other injuries, do not touch or block the steam outlet and do not open the water tank lid in a rush while the appliance is in operation.
16. Do not use the appliance to heat anything other than water. Do not fill above the maximum fill line. Do not operate if water is below the minimum fill line as this can damage the heating element.
17. Always unplug the appliance and allow it to cool before cleaning.
18. Note that the heating element surface is subject to residual heat after use.

## GET TO KNOW THE WOLSTEAD INSTANT HOT WATER DISPENSER

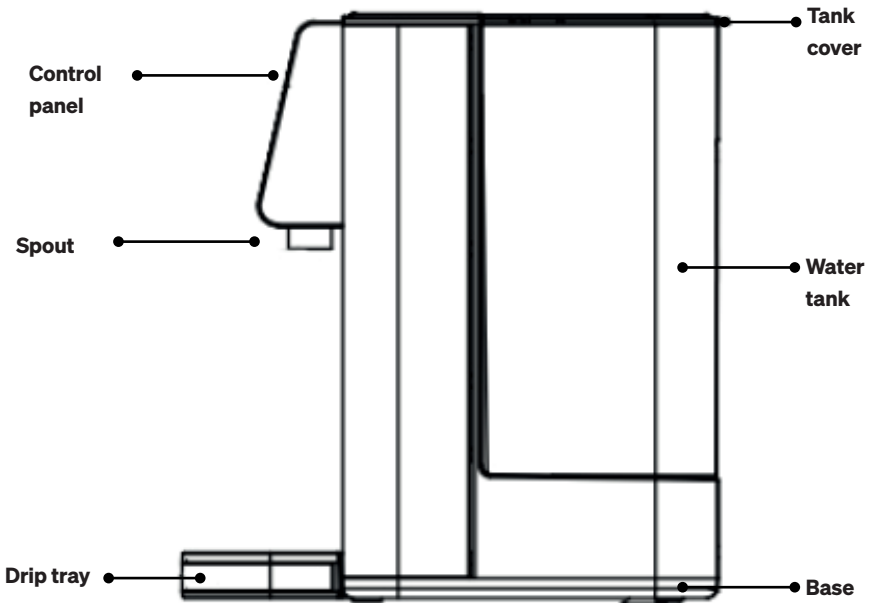

## INTRODUCTION TO THE CONTROL PANEL

**Descaling:** This appliance is programmed to indicate a descale is required when cumulative use has reached 10 hours. The descaling light will flash to remind you that a descale is required. Press the volume button for three seconds to enter the descaling mode. For best results, add some citric acid or vinegar into the water, fill the water tank to the maximum fill line and let the water dispense out until empty. The descaling light will then turn off.

**Temp button:** Set the desired temperature from room temp, 45°C, 55°C, 65°C, 75°C, 85°C, 100°C

**Lock button:** Press for three to five seconds to unlock.

**Lack of water:** When the water in the tank drops below the minimum level, the lack of water indicator will flash to remind you to refill the water tank. Refill the tank before continuing to operate.

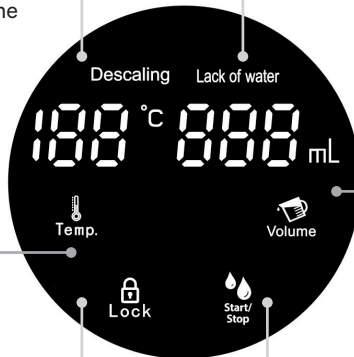

**Volume button:** Choose from five water volume settings: Continuous flow, 100mL, 200mL, 300mL, or 400mL, for precise pouring every time

**Start/Stop button:** Start and stop function setting.

# OPERATING INSTRUCTIONS

## Before first use

Before first use, clean the appliance by wiping the exterior with a damp cloth. Fill the water tank to its maximum capacity, switch the appliance on, and run it until all the water has been dispensed. Repeat this process two to three times for optimal cleanliness.

1. Ensure the plug is connected to a suitable wall outlet, then open the water tank lid and fill with water up to the maximum level, then securely close the lid. Place your cup on the removable drip tray, making sure it's properly aligned with the spout. Hold the lock button for three to five seconds to unlock the appliance.  
Note: Ensure the water level stays between the minimum and maximum markings on the tank, do not underfill or overfill.
2. Select your preferred temperature and volume, then press the Start/Stop button to begin operation. After approximately five to 10 seconds, water will start flowing continuously. To stop the appliance at any time, press the Start/Stop button again to stop the flow. To dispense more water, simply repeat the process.
3. If you notice the temperature is inaccurate, you can recalibrate it using the following steps:
  - a. Fill the water tank to the maximum level. Press and hold the temp button for three seconds until the temperature display shows 'AUT' and the volume display shows '000'. Then press the Start/Stop button to begin calibration. The appliance will enter adjustment mode and automatically exit after approximately four to five minutes. During this process, water will dispense from the nozzle, so be sure to place a large container underneath to catch the flow.

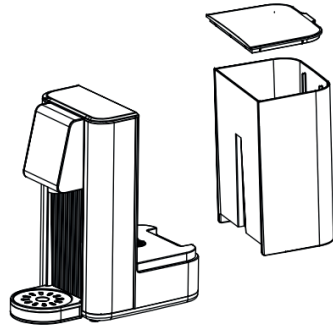

## Tips and usage notes

- Avoid contact with hot water or steam to prevent burns.
- If the appliance stops operating and the lack of water indicator starts flashing, refill the water tank with water immediately.
- The appliance will remember the last settings used, as long as it remains plugged in.
- Due to daily changes in ambient temperature, water output may vary by  $\pm 15\%$ .
- After cleaning the appliance, remove the water tank and empty any remaining water and dry thoroughly before storing.
- If water appears to be leaking from the bottom of the appliance, tighten the drainage stopper.
- When the water tray is full, hold the appliance steady with one hand and gently lift the tray with the other to remove it. Empty the drip tray, then slide it back into place with a firm but gentle push.

The appliance is equipped with a manual thermostat to restore heating in the event of abnormal operation. If the appliance loses power, stops working, or fails to boil water, allow it to cool down completely. Once cooled, unplug the appliance and use a pointed object to press the reset button located on the back of the unit several times. Then plug it back in and resume normal operation.

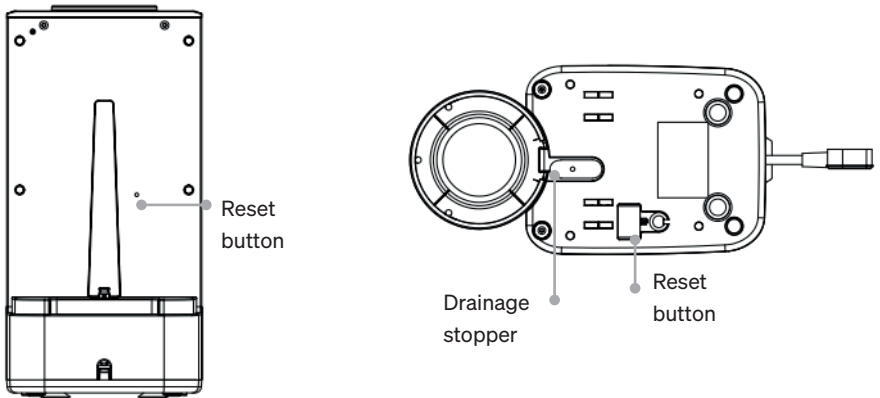

## CLEANING AND MAINTENANCE

1. Always switch off and unplug the water dispenser before cleaning, and allow it to cool completely.
2. To maintain optimal performance, it's recommended to descale the appliance when the descaling indicator flashes. This appliance is programmed to indicate a descale is required when cumulative use has reached 10 hours. The descaling light will flash to remind you that a descale is required. Press the volume button for three seconds to enter the descaling mode. For best results, add some citric acid or vinegar into the water, fill the water tank to the maximum fill line and let the water dispense out until empty. The descaling light will then turn off.
3. Use only a damp cloth to clean the appliance housing. Avoid any chemicals, abrasive cleaners, metal, or wooden tools.

## TROUBLESHOOTING GUIDE

Here are some possible issues with your hot water dispenser and solutions for troubleshooting. If problems persist or the machine is seriously damaged, please contact Kitchen Warehouse Customer Service for assistance.

Error message	Problem	Solution
Lack of water indicator flashing	Lack of water	Refill or top up the water tank to the maximum fill line
Display showing E5	Issue with the temperature sensor of water inlet	Contact Kitchen Warehouse Customer Service
Display showing E4	Issue with the temperature sensor of water outlet	Contact Kitchen Warehouse Customer Service
Display showing E0	PC board has problem	Contact Kitchen Warehouse Customer Service

# WARRANTY

## Get in touch with Customer Service

If you experience any issues with your Wolstead Instant Hot Water Dispenser, get in touch with our Customer Service team by email at [customerservice@kitchenwarehouse.com](mailto:customerservice@kitchenwarehouse.com), au or by phone on 1800 332 934 between the hours of 9am and 7pm (AEST) Monday to Friday. Alternatively you can use the Live Chat function on our website by visiting [www.kitchenwarehouse.com.au/contact-us](http://www.kitchenwarehouse.com.au/contact-us)

## 90 day money back guarantee

We promise you a full refund within 90 days if your Wolstead product does not fulfil your expectations. This guarantee applies to qualified purchases of all Wolstead branded products from participating stockists online and in-store from eligible delivery locations. The qualified product must be returned within 90 days from the date of purchase. We shall issue a full refund when the customer presents proof of purchase. We shall issue a store credit when proof of purchase is unavailable. The product packaging is not required to avail of the refund. The amount refunded will be the price of the products in the currency shown on the proof of purchase.

## Exclusions

This warranty does not apply if proper care and/or usage instructions are not followed. This warranty does not cover scratches, stains, discoloration or damage caused by misuse.

## How to claim

If a fault/defect is identified cease using the Product immediately. To make a claim on this guarantee, take the Product, proof of purchase and full details of the alleged defect to any Kitchen Warehouse store.

## Limitations

We make no express warranties or representations other than as set out in this guarantee. The replacement of the Product or the refund of the purchase price is the absolute limit of our liability under this guarantee.

## Warranty

Our goods come with guarantees that cannot be excluded under the Australian Consumer Law. You are entitled to a replacement or refund for a major failure and for compensation for any other reasonably foreseeable loss or damage. You are also entitled to have the goods repaired or replaced if the goods fail to be of acceptable quality and the failure does not amount to a major failure.

The benefits of this warranty are in addition to any rights and remedies imposed by Australian State and Federal legislation that cannot be excluded. Nothing in this warranty excludes, restricts or modifies any State or Federal legislation applicable to the supply of goods which cannot be so excluded, restricted or modified.

## Guarantee

We warrant that, subject to the exclusions and limitations below, the Product will be free from defects in materials and workmanship under normal domestic household use for the 12 month warranty period. The warranty period commences on the date of sale by the original retailer to the original purchaser. The warranty applies only while the Product is owned by the original purchaser.

Use of the Product in a commercial capacity will void this warranty. If a defect appears in the Product before the end of the warranty period and we find the Product to be defective in materials or workmanship, we will replace the Product with a product comparable in quality and value.

We reserve the right to change or discontinue our product ranges at any time without notice and without liability.



# WOLSTEAD

Distributed by Kitchen Warehouse.

Wolstead is a registered trademark of Kitchen Warehouse Pty Ltd. The printed material appearing in this document and related packaging is protected by copyright.

Kitchen Warehouse Pty Ltd  
1 Pensioner Guard Road  
North Fremantle, WA, 6159  
[www.kitchenwarehouse.com.au](http://www.kitchenwarehouse.com.au)  
1800 332 934  
[customerservice@kitchenwarehouse.com.au](mailto:customerservice@kitchenwarehouse.com.au)