

WOLSTEAD

Swift

French Door Digital Air Fryer Oven 28L

Owner's Manual



IMPORTANT:

This instruction manual contains important information necessary for the proper assembly and safe use of the appliance.

Read and follow all warnings and instructions before assembling and using the appliance. Keep this manual for future reference.

SPECIFICATIONS

- Voltage: 220-240V
- Frequency: 50/60Hz
- Capacity: 28L
- Wattage: 2400W
- Product size: 45.39 × 42.29 × 37.18cm
- Inside the cavity: 36.80 × 33.19 × 24.99cm
- Temperature: 30°C to 230°C
- Time control: up to 72 hours

Electrical power: If the electrical circuit/plug is overloaded with other appliances, your appliance may not operate properly. It should be used on a separate electrical circuit from other appliances.

KEY FEATURES AND BENEFITS

- French door opening with a large 28 litre cooking capacity.
- Dual zone air fryer allows synchronised cooking of two foods at the same time, or remove the divider for single zone, large scale cooking.
- French double door design means the left and right sides can be heated and opened separately.
- Seven toasting settings and 10 preset cooking programs.
- Easy to read digital screen.
- 30°C to 230°C temperature range.
- 12 handy accessories including three Ceramax non-stick baking pans, a rotisserie set, and wire racks and baskets so you can cook multiple foods at the same time.
- Ability to fry, grill, bake or roast.
- 360 degree rapid hot air circulation for fast heating.
- Ceramax ceramic non-stick coating which is free from PFAS or PTFE.

What's in the box?

- 2 x air fry baskets small
- 1 x air fry basket large
- 1 x wire rack small
- 1 x wire rack large
- 2 x Ceramax non-stick baking pan small
- 1 x Ceramax non-stick baking pan large
- 1 x crumb tray
- 1 x divider
- 1 x rotisserie set
- 1 x rotisserie fetch tool
- 1 x owner's manual



NON-STICK COATING

The three baking pans feature a hard, durable, ceramic non-stick coating called Ceramax which is more environmentally friendly than traditional non-stick. Ceramax is thermo-resistant, oven safe to 285°C, easy to clean, and free from lead, cadmium, PFOA and PFAS.

SAFETY PRECAUTIONS

When using this product, the following safety measures must be observed:

- This appliance is not intended for use by persons (including children) with reduced physical, sensory or mental capabilities, or lack of experience and knowledge, unless they have been given supervision or instruction concerning use of the appliance by a person responsible for their safety.
- Children should be supervised to ensure that they do not play with the appliance.
- If the supply cord is damaged, it must be replaced by the manufacturer, its service agent or similarly qualified persons in order to avoid a hazard.
- The appliance is not intended to be operated by means of an external timer or separate remote control system.
- This appliance is intended to be used in household and similar applications such as:
 - Staff kitchen areas in shops, offices and other working environments.
 - Farmhouses.
 - By clients in hotels, motels and other residential type environments.
 - By bed and breakfast type environments.

Read all instructions prior to first use and retain this instruction manual for future use.

1. Do not use the appliance for anything other than the intended use.
2. Remove all packaging materials and any stickers or labels from your appliance prior to first use.
3. The temperature of the appliance's outer surfaces may be high when the appliance is in use and for some time after use. The use of gloves is recommended when opening the air fryer.
4. To protect against electrical shock, do not immerse the cord, plugs or appliance in water or other liquids.
5. Unplug when not in use and before cleaning. Allow to cool before handling parts and cleaning the appliance.
6. Do not operate the appliance with a damaged cord or plug. Do not operate if the appliance malfunctions or has been damaged in any manner. Return the appliance to your nearest Kitchen Warehouse store for assistance. Do not use or attempt to repair the malfunctioning appliance.
7. Do not leave the appliance unattended during use.
8. Do not let the power cord hang over the edge of the table or counter, or touch hot surfaces.
9. Do not place the appliance on or near a hot gas or electric burner, or in a heated oven.
10. Do not use outdoors.
11. Always use the appliance on a flat, stable, heat resistant surface away from water.
12. Always leave at least 20cm of free space at the back, sides and top of the appliance while in use.
13. Do not cover or obstruct the air outlets or inlets on the back and sides of the air fryer with any objects, or block the outlets by positioning the air fryer against a wall.
14. Oversized foods and metal utensils must not be inserted into the air fryer oven as this may create a fire or risk of electric shock.
15. Do not place paper, cardboard or plastic inside the air fryer while in use.
16. Do not clean with metal scouring pads. Pieces can break off the pad and touch electrical parts, creating a risk of electric shock.
17. If you see dark smoke coming from the air fryer, immediately switch off and unplug the appliance. Wait for the smoke to clear before you open the appliance.

SAFEGUARDS FOR OPERATION AND USE

1. To avoid danger, the product is only suitable for the purpose indicated in this manual. Do not use this product or any part for other purposes. If it is operated incorrectly, it may cause injury.
2. Do not put flammable materials around the product or in the furnace chamber.
3. When baking food that will drip fat, oil or other liquids, we recommend you place the baking pan/s below the crisper tray, rotisserie or oven rack to prevent food from dripping onto the lower heating elements. This will protect the element from damage and reduce the risk of fire.
4. Do not use the furnace chamber for storage.
5. During use, the product will become hot. Avoid touching the furnace cavity.
6. When cooking, avoid opening the door, otherwise it will cause steam loss and affect cooking.
7. Be careful when opening the furnace door. Avoid damage to the furnace door glass or door handle.
8. Always check that any cookware you are using in the air fryer oven is heat resistant to the temperature which you are using.
9. In the event of the appliance catching fire, immediately unplug the power plug or turn off the main power switch. Do not use water to extinguish the fire, lest the glass door burst.
10. To prevent glass cracking, do not wipe the wet glass with a cold, wet cloth while the appliance is in use.
11. We recommend you place food in the air fryer basket to facilitate air flow for a crispier result, rather than directly on the baking pans.

SETTING UP YOUR AIR FRYER

Wash all accessories in hot, soapy water, then rinse and dry thoroughly.

A test run will help you become familiar with your oven, make sure it's working correctly, and clean it of possible residues.

1. Make sure there is no food or packaging in the oven and plug it in.
2. Press ROAST, then press START to begin heating.
3. The button will light up, and the display will show the timer counting down.
4. The oven will stop heating and beep several times when finished.

GETTING TO KNOW YOUR WOLSTEAD SWIFT FRENCH DOOR DIGITAL AIR FRYER OVEN

1. Control panel
2. Control knob
3. Housing
4. Door
5. Handle
6. Heating elements
7. Divider
8. Air fry basket
9. Wire rack
10. Baking pan
11. Crumb tray
12. XL Air fry basket
13. XL Wire rack
14. XL Baking pan
15. Rotisserie set
16. Rotisserie fetch tool

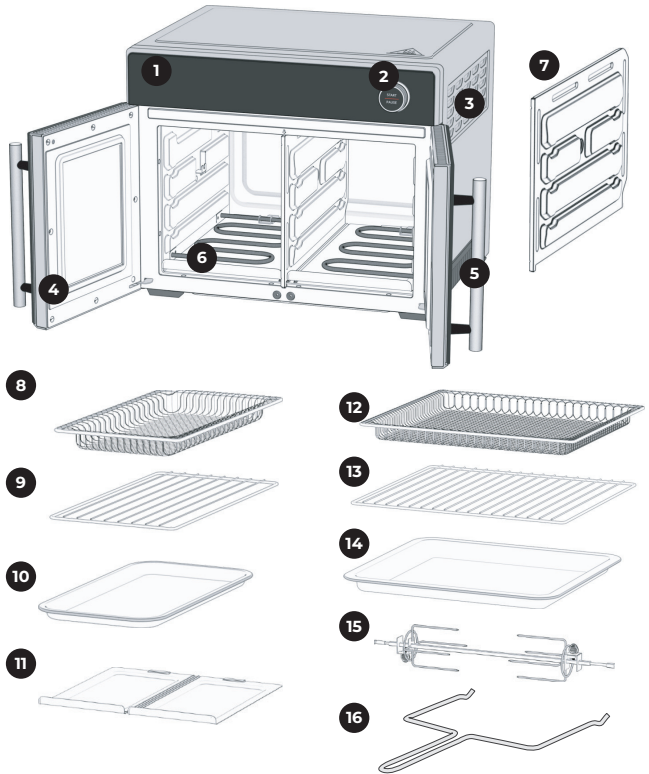

USE OF OVEN ACCESSORIES

Using the crumb tray

- Slide the crumb tray into the bottom of the inside of the appliance (below the heating elements; see Figure 1).
- Never operate the appliance without the crumb tray in place.
- If the crumb tray becomes more than half full, pause the cooking process and clean the crumb tray before continuing.
- To remove, use oven mitts and pull the crumb tray straight out of the appliance.

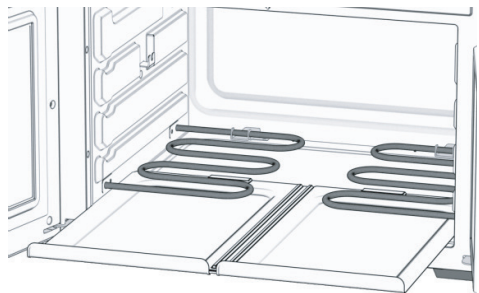

Figure 1

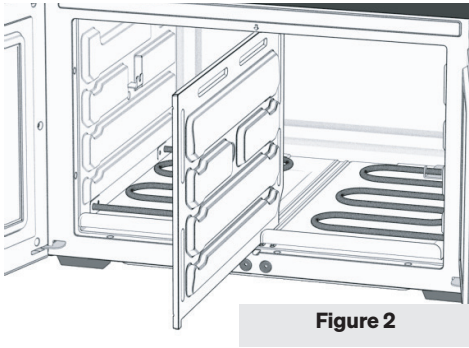

Figure 2

Using the divider

- To insert the divider into the appliance, slide the divider onto the rail inside the appliance (see Figure 2). Ensure that the indentation in the divider is facing upward. Push the divider all the way into the appliance.
- The divider must be inserted into the appliance to use the dual zone cooking mode. Remove the divider to use the appliance's single zone cooking mode.
- To remove, use oven mitts and pull the divider straight out of the appliance.

Using the air fry baskets, wire racks and baking pans

- The divider must be in place when using the small air fry basket, wire rack and baking pan (see Figure 3).
- Remove the divider when using the XL air fryer basket, wire rack and baking pan (see Figure 4).
- Select a shelf for your chosen accessory and cooking mode.
- When cooking food that drips, we recommend you place the baking pan below the crisper tray, rotisserie or oven rack to prevent food from dripping onto the lower heating elements.

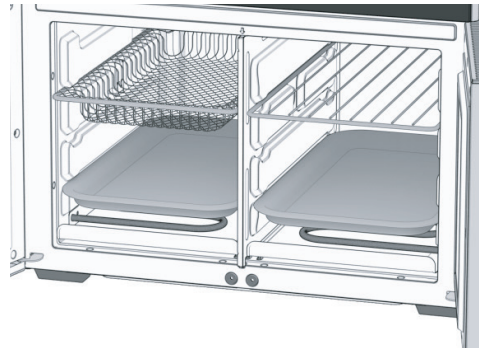

Figure 3

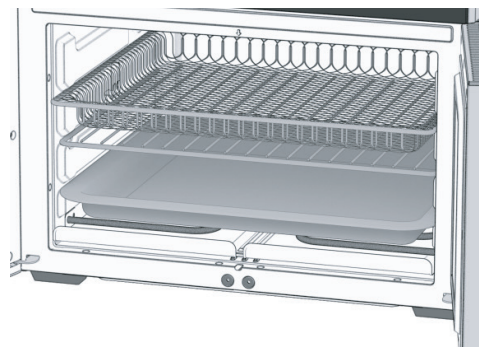

Figure 4

Using the rotisserie set

- When using the rotisserie, we recommend you place the baking pan on the bottom shelf to prevent oil dripping onto the lower heating element.
- Place the whole chicken (or other food item) on the rotisserie shaft. Place the rotisserie forks on either side of the shaft and insert them into the chicken to secure it on the shaft. Tighten the knobs on the forks to secure them (see Figure 1-3).
- Use the rotisserie handle to place the chicken inside the oven, securing both ends of the rotisserie shaft into the rotisserie slots (see Figure 4).
- If cooking a rotisserie chicken, we recommend you use cooking string to tie the legs and the wings to the body of the chicken to prevent them from dropping or catching as they rotate.



Rotisserie set



Rotisserie fetch tool

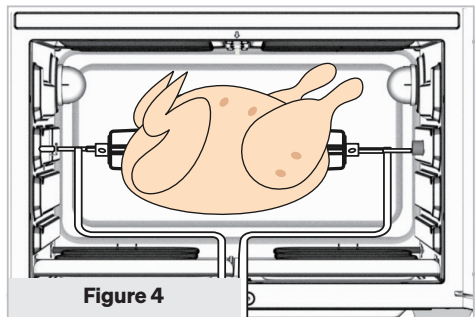
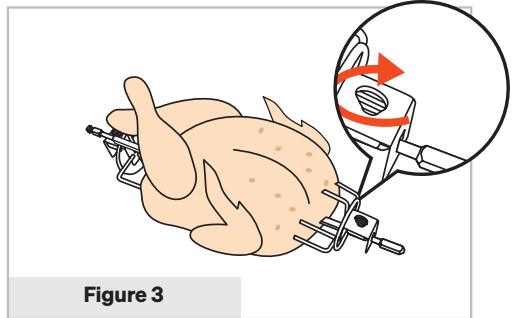
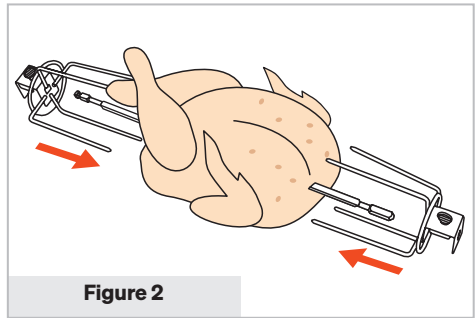
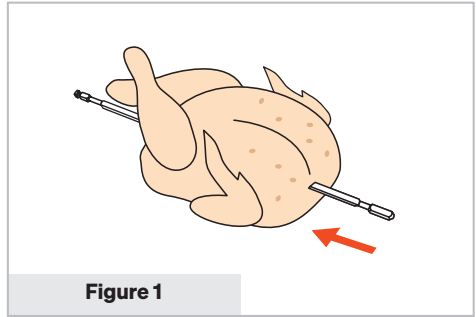

CONTROL PANEL

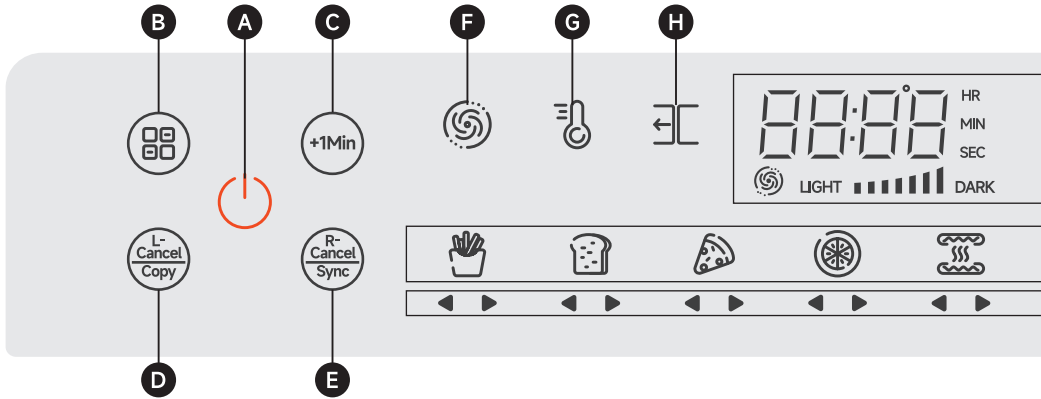

A. POWER button:

- Press to turn the oven on/off.
- Mute function: Press and hold for five seconds to mute the sounds. When the appliance is muted, press and hold for five seconds to unmute the appliance.

B. Multi-cook button:

- Advanced multi-step function cooking technology allows you to program your oven to start cooking with one preset, then automatically transition to the next preset for a perfect cook on any meal (this function can only be used in single zone).

C. +1 Min. button:

- Quickly add time during the cycle, or within two minutes after finishing the cycle, to continue cooking. Each press increases one minute.

D. L-Cancel button:

- Press to cancel an active cooking process for the left zone or single zone.

Copy button:

- Press and hold for three seconds to automatically copy left or right settings; and the other side to cook a larger amount of the same food, or cook different foods using the same function, temperature, and time.

E. R-Cancel button:

- Press to cancel an active cooking process for the right zone or single zone.

Sync button:

- Press and hold for three seconds to automatically sync the cook times to ensure both zones finish at the same time, even if there are different cook times.

F. Conv. button:

- Press to turn the fan on/off. The fan is automatically set when using the air fry or dehydrate functions.

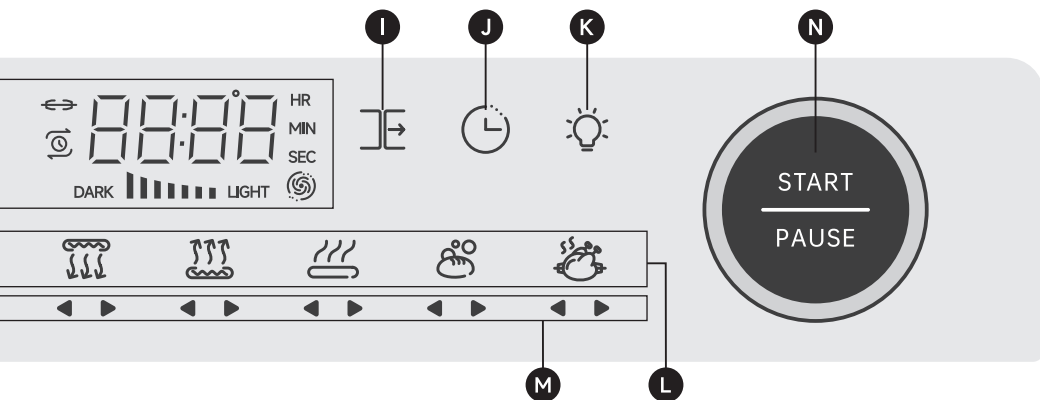

G. Temp button:

- Press once to adjust temperature. Turn the control knob clockwise to increase the setting and counterclockwise to decrease the setting.
- Temperature will adjust in increments of +/- 5°C (+/- 5°F).
- Press and hold to switch temperature units between Celsius and Fahrenheit.

H. Left button:

- Controls the output of the left zone in dual zone mode.

I. Right button:

- Controls the output of the right zone in dual zone mode.

J. Time button:

- Press once to adjust time. Turn the control knob clockwise to increase the setting and counterclockwise to decrease the setting.

K. Light button:

- Press to turn the interior light on/off.

L. Cooking functions display:

- Shows the function setting.

M. Dual zone mode:

- Left cavity and right cavity indicators.

N. Control knob:

- Turn the knob to change cooking functions. The current function will blink on the display.
- After pressing the Temp button/ Time button, turn the knob to change temperature/time. Turn clockwise to increase and counterclockwise to decrease.
- START/PAUSE function: Press to start or pause the cooking process.

Time Increment Chart	
Below 30 minutes	+/- 1-minute increments
30 minutes-2hours	+/- 5-minute increments
2hours-12hours	+/- 10-minute increments
12hours-72hours	+/- 30-minute increments

COOKING MODES

Single zone mode

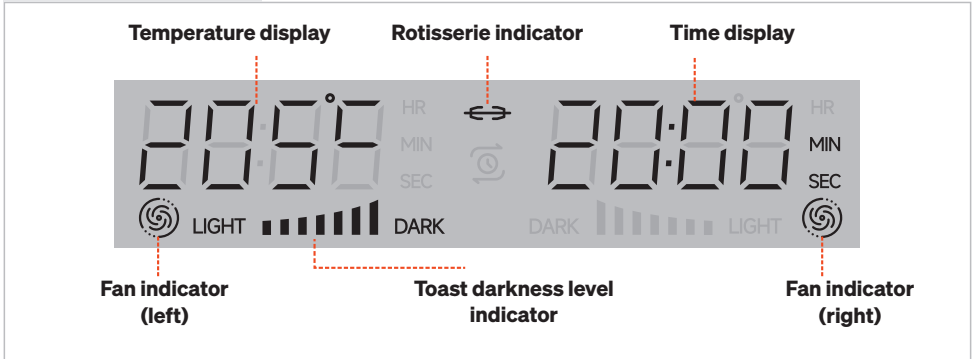

Dual zone mode

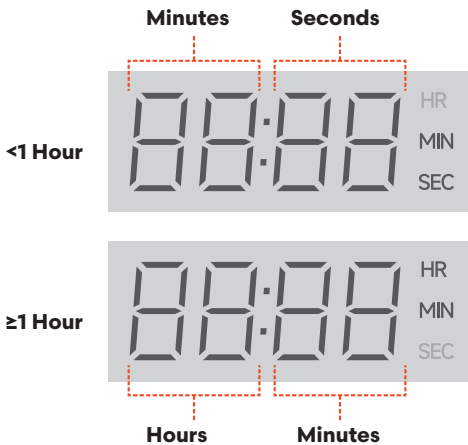
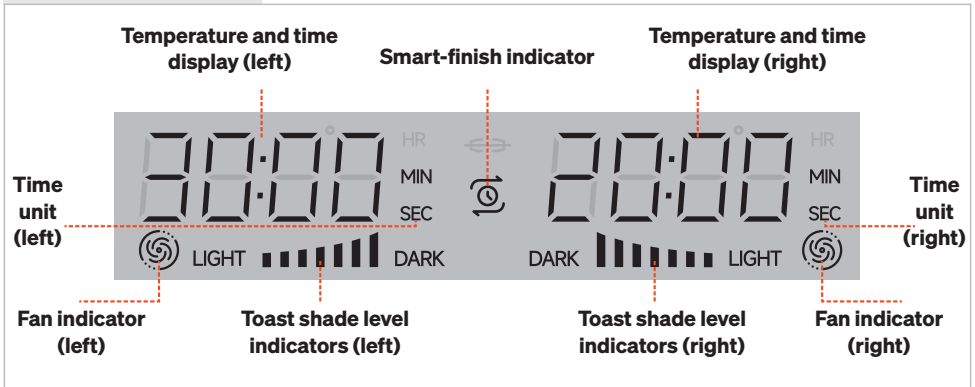

Cook time remaining	Display format
<1 Hour	Minutes: Seconds
≥1 Hour	Hours: Minutes

NOTE: When you're setting cook times, the oven display will use the Hours:Minutes format

COOKING WITH YOUR WOLSTEAD SWIFT FRENCH DOOR DIGITAL AIR FRYER OVEN

Caution

The outer surface of the oven, including the oven door, is hot during and after use. Temperature may be over 100°C. To prevent burns or personal injury, ALWAYS use protective hot pads or insulated oven mitts, use the available handles and never place anything on top of the appliance when it is in use.

NOTE: Always make sure the crumb tray is properly in place at the bottom of the oven when cooking. To prevent fat, oil or other mess dripping onto the lower heating element, use the baking pans on the lowest shelf directly above the element when cooking.

Cooking functions

Cooking functions are programmed with an ideal time and temperature for cooking certain foods. For more information on each cooking function, see the Cooking Functions Quick Reference Chart.





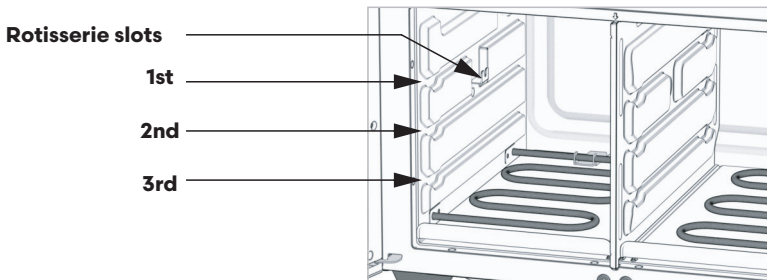





Positioning the racks

Each cook function corresponds to a specific oven and rack level. See the chart below to determine the recommended accessory and rack level for each cook function. For best results, use only the recommended accessories for each function and remove others from the oven.



SUGGESTED POSITION										
	Air fry	Toast	Pizza	Dehydrate	Roast	Broil	Bake	Reheat	Ferment	Rotisserie
1st	✓			✓						Rotisserie slots
2nd			✓	✓		✓				
3rd		✓			✓		✓	✓	✓	

COOKING FUNCTIONS QUICK REFERENCE CHART

Function	Use	Suggested Accessory	Range
 Air fry	<ul style="list-style-type: none"> Cooks using intense heat and maximised airflow Cooks food such as French fries and chicken wings 	Air fry basket	<ul style="list-style-type: none"> 100 - 230°C (210 - 450°F) 1 min - 1 hr
 Toast	<ul style="list-style-type: none"> Toast or brown bread Up to 9 slices (single zone) or 3 slices (dual zone) 	Wire rack	<ul style="list-style-type: none"> Toast shade level 1-7 Time and temperature are automatic
 Pizza	<ul style="list-style-type: none"> Melt and brown cheese and toppings while crisping crust Includes automatic preheat Up to 13 inches (single zone) or 6 slices (dual zone) 	Wire rack	<ul style="list-style-type: none"> 100 - 230°C (210 - 450°F) 1 min - 1 hr
 Dehydrate	<ul style="list-style-type: none"> Evenly dry out food without cooking Dry fruit or vegetable chips 	Wire rack	<ul style="list-style-type: none"> 35 - 95°C (95 - 205°F) 1 min - 72 hr
 Roast	<ul style="list-style-type: none"> Cook a variety of meats and poultry Food will be tender and juicy on the inside and well roasted on the outside 	Baking pan	<ul style="list-style-type: none"> 100 - 230°C (210 - 450°F) 1 min - 1 hr
 Broil	<ul style="list-style-type: none"> Cook open sandwiches, thin cuts of meat (such as bacon), poultry, fish, sausages and vegetables Brown the tops of casseroles, gratins and desserts 	Baking pan	<ul style="list-style-type: none"> 100 - 210°C (210 - 410°F) 1 min - 1 hr
 Bake	<ul style="list-style-type: none"> Cook food evenly throughout Bake cakes, muffins, pastries 	Wire rack	<ul style="list-style-type: none"> 100 - 180°C (210 - 360°F) 1 min - 1 hr
 Reheat	<ul style="list-style-type: none"> Heat leftovers without over cooking 	Wire rack	<ul style="list-style-type: none"> 100 - 230°C (210 - 450°F) 1 min - 1 hr
 Ferment	<ul style="list-style-type: none"> Precisely hold low temperatures Proof bread, rolls, pizza and dough Make yoghurt 	Baking pan	<ul style="list-style-type: none"> 30 - 45°C (90 - 110°F) 1 min - 9 hr
 Rotisserie	<ul style="list-style-type: none"> Cook rotating roast, such as a whole chicken Up to 2.3kg <p>Note: Also requires baking pan at low position to collect drippings.</p>	Rotisserie assembly	<ul style="list-style-type: none"> 100 - 210°C (210 - 410°F) 1 min - 1 hr

SPECIAL FUNCTION USE

Multi-cook

Single zone mode



In the multi-cook single zone function, you can set the air fryer oven to automatically complete one preset function, followed immediately by another preset function. For example, you might choose to set it to roast first and then immediately switch over to air fry to finish crisping meats.

Note: The Toast preset cannot be used for the multi-cook function.

1. After turning on the air fryer oven, select the first preset function you want to use, for example, air fry, and adjust the time and temperature.

2. Then press the multi-cook button.

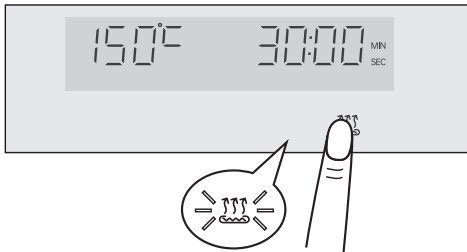
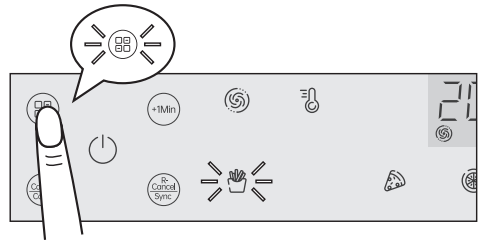

3. Then choose the second preset function and adjust the time and temperature.

4. Once you've chosen the second preset, press multi-cook button again, followed by the START/PAUSE knob to commence cooking.

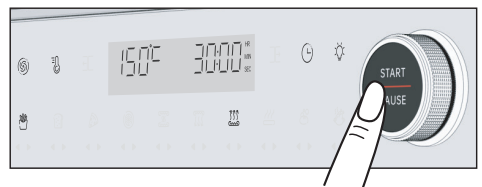

4.1. The first preset function will start and the display will show the temp and time of the first preset (see picture below on the left). Every few seconds, the screen will switch between displaying this and showing the total time of both presets and counting down (see picture below on the right).



(Temperature and time of the preset)

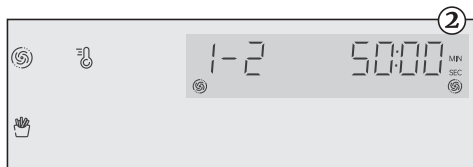

(Step and total time)

4.2. Once the first preset has completed, the second preset will display.

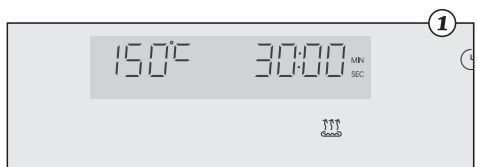

(Temperature and time of the preset)

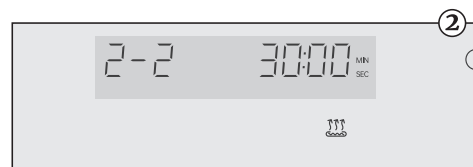

(Step and total time)

4.3. Once the second preset has completed, the appliance will beep and END will appear on the display.

+1 Minute

Single zone mode



You can easily add additional time to cooked foods.

While cooking, touch the +1 Min. button to increase cooking time, up to 10 minutes.

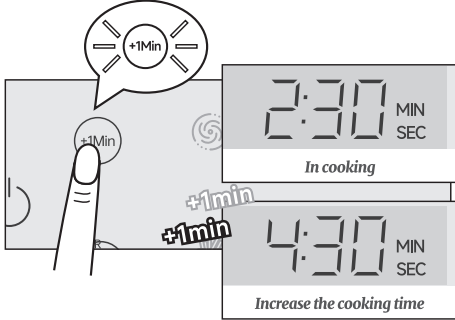

Within two minutes after the cooking ends, touch the +1 Min. button to easily restart and add additional cooking time to 30 minutes.

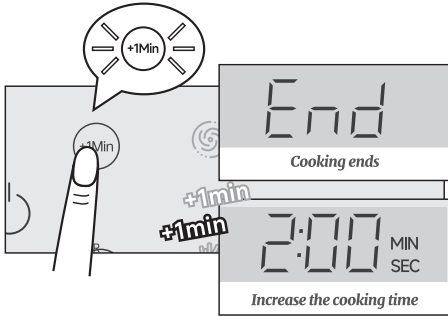

+1 Minute

Dual zone mode



You can easily add additional time to cooked foods.

1. You need to select the Left or Right button before operating this function.

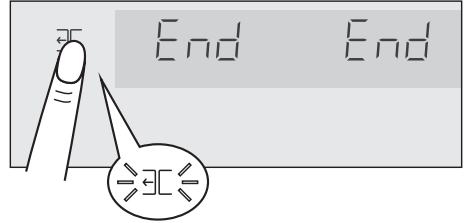

2. Within two minutes after the cooking ends, touch the +1 Min. button to easily restart and add additional cooking time to 30 minutes.

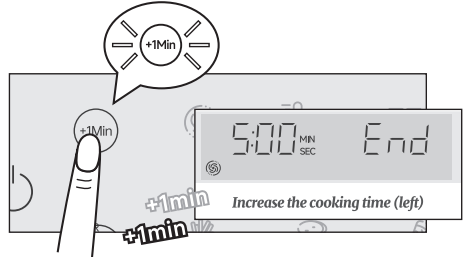

NOTE: This function is not operational during single zone multi-cook.

COPY-COOK

Dual zone cooking

To cook a larger amount of the same food, or cook different foods using the same function, temperature, and time.

1. Press the left button and it will blink. Select the desired cooking function. Use the Temp button and control knob to set the temperature, and then use the Time button and control knob to set the time.

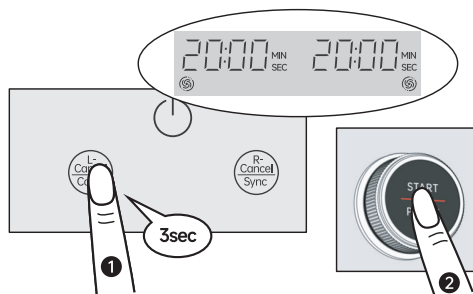
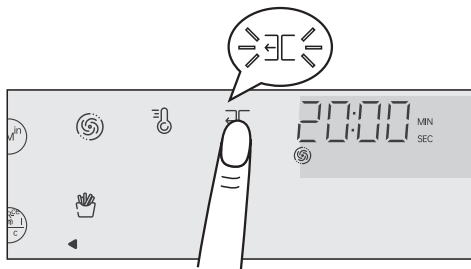

2. Press and hold the Copy-cook button for three seconds to copy the left zone settings to right zone. Then Press START/PAUSE to begin cooking in the dual zone.

3. 'End' will appear on both screens when cooking ends at the same time.

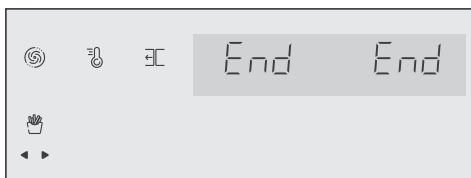

*You can also copy the 'Right' cavity setting to 'Left'

SYNC

Dual zone cooking

To finish cooking at the same time when foods have different cook times, temps, or even functions.

1. Touch the Left function and it will blink. Select the desired cooking function. Use the Temp button and control knob to set the temperature, and then use the Time button and control knob to set the time.

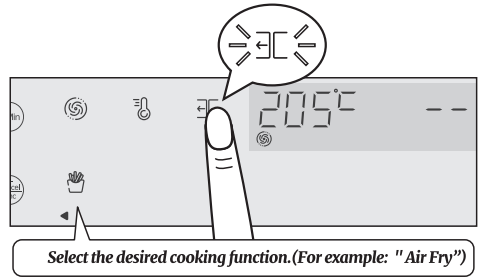
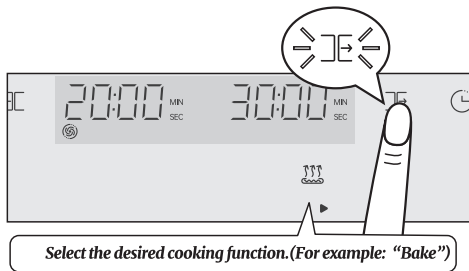

2. Touch the Right function and it will blink. Select the desired cooking function. Use the Temp button and control knob to set the temperature, and then use the Time button and control knob to set the time.

3. Press and hold the Sync button for three seconds. Then press the START/PAUSE knob to begin cooking in the cavity with the longest time. The other cavity will display Hold. The unit will beep and activate the second cavity when both cavities have the same time remaining.

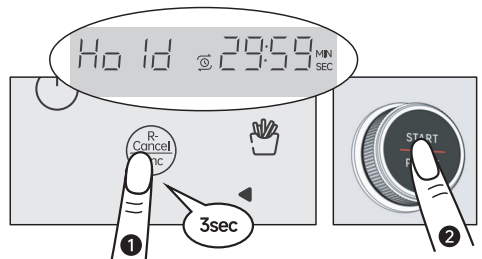

NOTE: It is recommended to shake your food during cooking. To keep the time at a synchronised finish, press the START/PAUSE knob to pause both cavities.

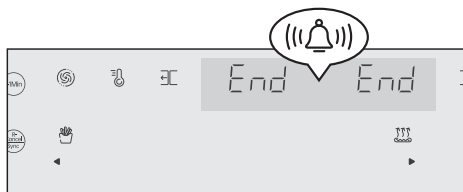

4. When cooking is complete, the unit will beep and 'End' will appear on the display.

NOTE: If you decide the food in one of the cavities is done cooking before the cook time is up, you can stop a cavity. Select that cavity, then press START/PAUSE knob to pause the cavity.

CARE AND MAINTENANCE

1. Clean oven accessories and oven interior after every use.
2. Do not use abrasive cleaners, metal scouring pads, or metal utensils on any part of the oven, including pans and other accessories. These will scratch or damage their surfaces.
3. Before cleaning, turn off and unplug the oven, allowing it to cool completely. Open the door for faster cooling.
4. Empty crumb tray by sliding it out of the oven.

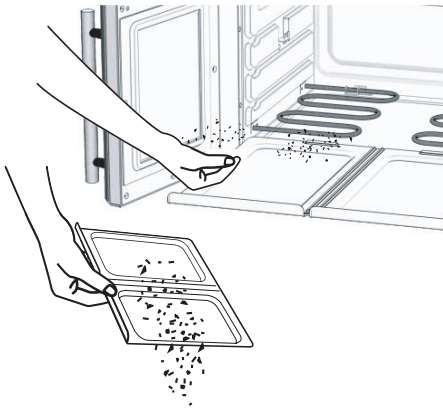

5. Apply non-abrasive liquid cleanser or a mild spray solution to a soft, damp cloth or sponge (not the oven surface) and wipe all parts of the oven.
6. To clean the glass door, use a glass cleaner or mild detergent and a soft, damp sponge or soft, plastic scouring pad.
7. Let all surfaces dry completely before plugging in or turning on the oven.
8. Keep the furnace cavity clean. After each use, the furnace chamber must be cleaned with warm water. If the spilled food residue or liquid remains in the furnace cavity, wipe it with a wet cloth first, and then wipe it dry. If the furnace chamber is very dirty, wipe it with a soft cotton cloth dipped with mild detergent.
9. After each use, the grill, steaming tray and baking tray must be cleaned to avoid oil smoke, fire or corrosion and rust caused by the accumulation of grease or food residue stains.
10. When cleaning the product surface, furnace door and furnace cavity, wipe it with a slightly wet soft cloth, and then wipe it dry. In order to prevent damage to the internal parts of the product, do not let water penetrate into the exhaust port.
11. Salt is an aggressive substance, which will form rust once accumulated in the furnace cavity. Some acidic sauces, such as tomato juice, mustard and pickled foods, contain chlorine and acid chemicals. These components will affect the surface of stainless steel. Therefore, it is recommended to clean the oven after each use.
12. Do not wet the control panel. If the control panel is wet, wipe it dry with a soft cloth. Before cleaning the control panel, unplug the power plug to avoid accidental operation. Never use detergent, abrasive or spray cleaners to clean the control panel.

CLEANING THE ACCESSORIES

1. Apply a non-abrasive liquid cleanser or a mild spray solution to a soft, damp sponge or soft, plastic scouring pad (not the accessory surface). Wipe accessories and soak in warm, soapy water if necessary.
2. For stubborn grease:
 - In a small bowl, mix two tablespoons of baking soda with one tablespoon of water to form a spreadable paste.
 - Use a sponge to spread the paste on the trays and scrub. Let the trays sit for 15 minutes before rinsing.
 - Wash trays with soap and water.
 - When washing the Ceramax non-stick baking pans, use warm soapy water and dishwashing detergent with a non-abrasive sponge to prevent damage to the non-stick surface.

Note: After each use, slide out the crumb tray and discard crumbs.

3. Thoroughly dry all parts before placing them back in the oven.

STORAGE

1. Clean and dry the oven and all accessories before storing.
2. Store the oven in an upright position. Do not store anything on top.

TROUBLESHOOTING

PROBLEM	POSSIBLE SOLUTION
<p>The oven will not turn on.</p>	<ul style="list-style-type: none"> • Make sure the power cord is securely plugged into the outlet. • Insert the power cord into a different outlet. • Reset the circuit breaker if necessary. • Press the power button.
<p>Food is not completely cooked.</p>	<p>Increase cooking temperature or time.</p>
<p>Food is overcooked or burned.</p>	<ul style="list-style-type: none"> • Decrease cooking temperature or time. • Make sure food is not too large and is not touching the heating elements.
<p>Food is cooked unevenly.</p>	<ul style="list-style-type: none"> • Make sure food is not too closely packed into a tray, rack, or other container. • Preheat the oven manually before cooking.
<p>White smoke or steam is coming out of the oven.</p>	<ul style="list-style-type: none"> • The oven may produce some white smoke or steam during cooking. This is normal. • During first use, dust from the packing process may cause white smoke. This is normal for toaster ovens and many other kitchen appliances. To eliminate any dust, see page 4, Setting Up Your Air Fryer. • Excess oil or fatty foods may produce white smoke. Make sure the inside of the oven is cleaned properly and free of grease.
<p>Dark smoke is coming out of the oven.</p>	<p>Immediately press “START/PAUSE” knob and unplug your oven. Food is burning. Wait for smoke to clear before opening the oven door.</p>

PROBLEM	POSSIBLE SOLUTION
A thermometer shows that the oven temperature is different from the oven setting.	Commonly used thermometers may have low sensitivity and take over 10 minutes to measure the correct temperature. This will not affect cooking.
Left cavity display shows error code “E1”.	<ul style="list-style-type: none"> • There is an open circuit in the temperature monitor of the left zone. • Contact Kitchen Warehouse Customer Service.
Left cavity display shows Error Code “E2”	<ul style="list-style-type: none"> • There is a short circuit in the temperature monitor of the left zone. • Contact Kitchen Warehouse Customer Service.
Right cavity display shows Error Code “E1”.	<ul style="list-style-type: none"> • There is an open circuit in the temperature monitor of the right cavity. • Contact Kitchen Warehouse Customer Service.
Why did a circuit breaker trip while using the unit?	The unit uses 1800 watts of power, so it must be plugged into an outlet on a 15-amp circuit breaker. It is also important that the unit be the only appliance plugged into an outlet when in use. To avoid tripping a breaker, make sure the unit is the only appliance plugged into an outlet on a 15-amp breaker.
Why is water dripping onto the counter from under the door?	This is normal. The condensation created by foods with a high moisture content (such as frozen breads) may run down the inside of the door and drip onto the counter.
Why is steam coming out from the oven door?	This is normal. Foods with a high moisture content may release steam around the door.
Why do the heating elements appear to be turning on and off?	This is normal. The oven is designed to control temperature precisely for every function by adjusting the heating elements’ power levels.

WARRANTY

90 day money back guarantee

We promise you a full refund within 90 days if your Wolstead product does not fulfil your expectations. This guarantee applies to qualified purchases of all Wolstead branded products from participating stockists online and in-store from eligible delivery locations. The qualified product must be returned within 90 days from the date of purchase. We shall issue a full refund when the customer presents proof of purchase. We shall issue a store credit when proof of purchase is unavailable. The product packaging is not required to avail of the refund. The amount refunded will be the price of the products in the currency shown on the proof of purchase.

Warranty

Our goods come with guarantees that cannot be excluded under the Australian Consumer Law. You are entitled to a replacement or refund for a major failure and for compensation for any other reasonably foreseeable loss or damage. You are also entitled to have the goods repaired or replaced if the goods fail to be of acceptable quality and the failure does not amount to a major failure.

The benefits of this warranty are in addition to any rights and remedies imposed by Australian State and Federal legislation that cannot be excluded. Nothing in this warranty excludes, restricts or modifies any State or Federal legislation applicable to the supply of goods which cannot be so excluded, restricted or modified.

Guarantee

We warrant that, subject to the exclusions and limitations below, the Product will be free from defects in materials and workmanship under normal domestic household use for the 12 month warranty period. The warranty period commences on the date of sale by the original retailer to the original purchaser. The warranty applies only while the Product is owned by the original purchaser. Use of the Product in a commercial capacity will void this warranty. If a defect appears in the Product before the end of the warranty period and we find the Product to be defective in materials or workmanship, we will replace the Product with a product comparable in quality and value. We reserve the right to change or discontinue our product ranges at any time without notice and without liability.

Exclusions

This warranty does not apply if proper care and/or usage instructions are not followed. This warranty does not cover scratches, stains, discoloration or damage caused by misuse.

How to claim

If a fault/defect is identified cease using the Product immediately. To make a claim on this guarantee, take the Product, proof of purchase and full details of the alleged defect to a Kitchen Warehouse store.

Limitations

We make no express warranties or representations other than as set out in this guarantee. The replacement of the Product or the refund of the purchase price is the absolute limit of our liability under this guarantee.