

DAVIS & WADDELL

essentials

Electric Fondue Set

DESECO4/DES0336

Thank you for choosing the Davis & Waddell Fondue 11 piece Set. To ensure proper operation and to maintain the lifespan of your appliance, please read these instructions carefully before use.

Features and parts

1. Colour Coded Forks x 8
2. Fondue pot
3. Resting plate
4. Heating base with hotplate
5. Adjustable thermostat
6. Luminated control dial

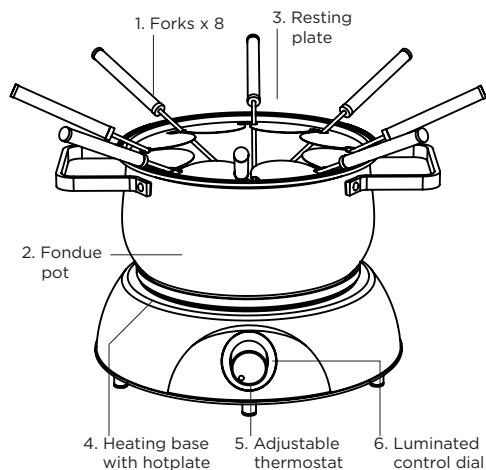

Safety First

Appliance is not intended to be used by individuals (including children) who have restricted physical, sensory or mental abilities and/or insufficient

knowledge and/or experience, unless they are supervised by an individual who is responsible for their safety or have received instructions on how to use the appliance.

- Keep away from sources of heat, direct sunlight and humidity.
- Never submerge into liquid.
- Do not use appliance with wet hands.
- Do not leave appliance running unattended. If you leave the room, switch it off and unplug.
- Check appliance and supply cord regularly for signs of damage. If damage is found, do not operate.
- If supply cord is damaged, it must be replaced by the manufacturer, its service agent or similarly qualified persons in order to avoid a hazard.
- This appliance is not intended to be operated by means of an external timer or a separate remote control system.
- Appliance is intended to be used in households and is not for commercial use.
- Supervise children to ensure they do not play with appliance.
- During operation surfaces of appliance will become hot. Avoid contact to reduce risk of burns.
- Leave a sufficient safety gap of 30cm around appliance.
- Switch off appliance after use.
- If appliance catches fire, never try to extinguish flames with water. Smother flames with fire blanket or wet towel.
- Do not move or carry appliance when hot. Hot liquids, steam and/or splattering may escape.
- Parts will remain hot after use, allow to cool.
- To ensure children's safety, keep all packaging out of reach.

Packaging and Recycling

The materials used for this product's packaging can be reused, recycled and disposed of through specific waste streams.

- **REUSE:** Keep packaging to safely store or transport your product, preventing damage.
- **RECYCLE:** Look for recycling symbols on packaging components to identify if they are recyclable. Check with your local authority to find out what materials are accepted for recycling in your area.
- **DISPOSE:** Look for symbols on packaging components and dispose of materials accordingly.

Operating Your Fondue Maker

Before First Use

Clean appliance and accessories as described under "Cleaning".

Making Fondue

Appliance must be used on a kitchen benchtop.

Place fondue pot on heating base and add ingredients as per a recipe. Do not fill past MAX level.

Place resting plate in fondue pot.

Turn thermostat to MIN.

Connect supply cord to a properly installed 240V - 50Hz safety socket.

Increase thermostat temperature and allow ingredients to heat.

When contents of fondue pot are ready, place pieces of food onto the fondue forks and dip into fondue pot.

Adjust thermostat so that fondue is kept at a simmer.

Switching off

To stop the cooking process, turn temperature control dial to the MIN setting and remove supply cord from outlet. Allow contents a considerable time to cool down.

NOTE: Control dial light indicates heating base is warming up. During use, control dial light will switch on and off. This is normal and indicates that the temperature in the fondue pot is being controlled and maintained.

Tips

- Classic cheese fondues are the most well-known, but you can also make chocolate fondue, wine fondue, or fondue bourguignonne in which food is cooked in oil (see recipes).
- When making fondue bourguignonne (in cooking oil), it is best to use liquid cooking oil with a very high smoke point. Do not fill past MAX.

Cleaning

- Turn thermostat to MIN and unplug. Allow appliance to completely cool.
- Wipe heating base with a damp cloth and dry with a dry cloth.
- Hand wash fondue pot and all accessories. Rinse and dry thoroughly. Do not wash in the dishwasher or surfaces may become dull.
- Never immerse heating base in water. This could lead to fire or electric shock/electrocution. Do not use any acidic or abrasive detergents or a wire brush.

Storage

- When cleaning or storing, switch off appliance and always pull our plug from outlet by the plug itself. Remove attachments.
- Allow appliance to cool before storing.

Our 12 month Guarantee

Our goods come with guarantees that cannot be excluded under the Australian Consumer Law. You are entitled to a replacement or refund for a major failure and compensation for any other reasonably foreseeable loss or damage. You are also entitled to have the goods repaired if the goods fail to be of acceptable quality and the failure does not amount to a major failure.

We stand by this product. Therefore we offer a 12 month guarantee on the heating element. The benefits of this guarantee are in addition to any rights and remedies imposed by Australian Consumer Law. Our guarantee excludes normal wear and tear and instances where care and use instructions have not been followed.

What IsAlbi will do: During this guarantee period IsAlbi will repair, replace or refund any defective product. If identical product is not available for replacement, a similar product may be offered. IsAlbi asks you to cover the cost of postage/transit if the product needs to be sent back to us for inspection. If IsAlbi deems the product is defective, we will reimburse your postage/transit expenses. IsAlbi will be responsible for the postage/transit of the repaired/replacement product back to you.

What to do: If a fault/defect is identified cease using the product immediately.

To make a claim on this guarantee, take the product, proof of purchase and full details of the alleged defect to the retailer from whom the product was purchased. If you cannot access the retailer or are unsatisfied with the solution offered by the retailer contact IsAlbi via the details below.

IsAlbi

87 Chifley Drive, Preston, Victoria 3072
P: +61 (03) 9474 1300
E: enquiries@isalbi.com.au
www.isalbi.com.au

Recipes

Classic Cheese Fondue (Serves 6)

Ingredients

- 375mL dry white wine
- 1 clove garlic
- 800g Gruyere cheese, grated
- 1 tbsp cornflour
- 4 tbsp cherry liqueur
- White pepper to taste
- French stick or bread sticks

Method

1. Cut bread into 2cm cubes and set aside.
2. Peel garlic, cut in half and rub on the inside of the fondue pot.
3. Mix cornflour and cherry liqueur together to form a paste.
4. Pour wine into fondue pot and heat till simmering.
5. Add grated cheese and stir until the mixture is smooth.
6. Add cornflour paste to cheese mixture and simmer for a further 2 minutes, stirring constantly.
7. Reduce heat to serve, skewer a piece of bread on fondue fork and dip into cheese

Cheese Fondue (Serves 6)

Ingredients

- 250mL dry white wine
- 250g Swiss cheese, grated
- 250g Gruyere cheese, grated
- ¼ tsp ground nutmeg
- French stick or bread sticks

Method

1. Cut bread into 2cm cubes and set aside.
2. Simmer wine in fondue pot. Add one cup of grated cheese at a time, stir after each addition of cheese has melted.

3. When all cheese has melted stir in nutmeg, turn down to low heat.

4. To eat, skewer a piece bread on fondue fork and dip into cheese

Chocolate Fondue (Serves 6)

Ingredients

- 4 tbsp icing sugar
- 4 tbsp cocoa powder
- Pinch cinnamon
- 2 tsp vanilla sugar
- 1kg dark or milk chocolate
- 2 bananas, sliced
- 2 oranges, segmented
- 2 pears, sliced
- 250g cherries pitted
- Any other seasonal fruit

Method

1. In a bowl, sift together the icing sugar, cocoa, cinnamon and vanilla sugar, combine and set aside.
2. Turn onto a low heat. Place chocolate in fondue pot and melt. Do not let the chocolate boil.
3. To eat, skewer a piece of fruit on fondue fork, turn in the sugar mixture and dip in the melted chocolate.

Traditional Chocolate Fondue (Serves 6)

Ingredients

- 500g dark chocolate, chopped
- 300mL thickened cream
- ½ cup condensed milk
- Seasonal fruits

Method

1. Pour condensed milk and thickened cream into fondue pot. Heat on low until mixture comes to the boil.
2. Remove pot from heat and add chocolate. Stir until chocolate has completely melted.
3. Return fondue pot to base and turn on low heat. Do not let contents boil.

4. To eat, skewer a piece of fruit on fondue fork and dip into chocolate.

Oil Fondue (Serves 6)

Ingredients

- 1.2kg beef tenderloin or 6 rump steaks, cut into 2.5/3cm cubes
- 1L good quality vegetable oil (use oil with a high smoke point)
- Crusty baguette, sliced
- Fresh green salad

Method

1. Season meat with salt and pepper.
2. Add oil to fondue pot and turn onto medium/high heat until oil is hot but not smoking.
3. Place meat onto fork and hold in oil for approximately 25-30 seconds for rare, 30-35 seconds for medium and 45-60 seconds for well done.
4. Pile onto sliced baguette and serve with a green salad, and condiments such as salsa verde, aioli and chilli vinegar.

Flavour variations

Try raw king or tiger prawns as well as or instead of beef.