

ACTA.PRO

AT LAST THERE'S A SYSTEM FOR CHANGE



Shelve your preconceptions about shelving.

At first glance, a static piece of furniture like a shelf seems to be the polar opposite of transformation in the workplace. We're asking you to Think again!

With ACTA.PRO we bring you a shelf system that bears little resemblance to the office bookcases and filing cabinets of days gone by. In fact it's groundbreaking – redefining the way we structure space thanks to its countless design options, lots of extras and the most diverse application possibilities.

ACTA.PRO will accompany you through the work transition. Get started!

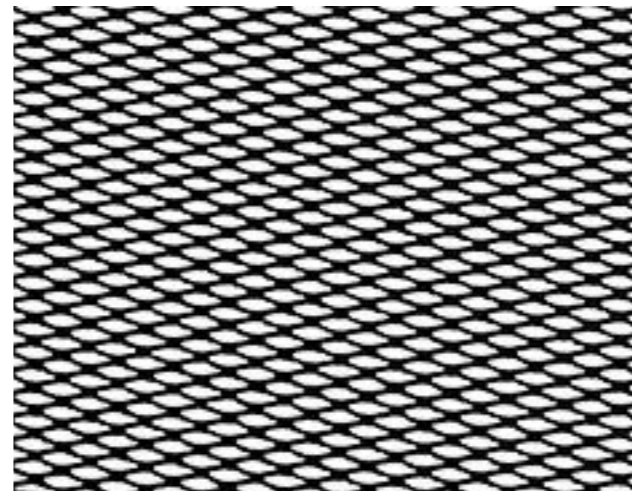

100 % MADE IN KARBEN AT OUR FACTORY

We use a material optimisation strategy to manufacture ACTA.PRO.

Just like all of our outfitting solutions, our new shelf system also has Blue Angel certification – and of course it's entirely made by us here in Germany.

WELCOME TO AN ORDERED WORLD

First impressions count. The principles of social interaction apply equally to offices. **In this scenario, ACTA.PRO gives visitors the sense that everything is well-organised, with secure locker modules, a wardrobe section, acoustic fleece elements and decorative planters** – and the same would be true for alternative configurations. Furthermore the shelf system acts as a visual and acoustic partition between the reception area and the rest of the office.

The HALO EFFECT, whereby we form an opinion about someone within milliseconds, is also true for spaces. Regardless of style preference, we perceive an atmosphere to be inviting if it's tidy, clean and aesthetically appealing.



Here, ACTA.PRO has been configured with lockers, corner modules and wardrobe elements. Sliding metal rear panels with flexible positioning options and fleece-covered acoustic sliding fronts are also used. Other products: NET.WORK.PLACE Wave and side tables

By the way – if your requirements change or you need some fresh ideas, you can reconfigure ACTA.PRO quickly and easily. Our patent-pending click connection technology helps to make this possible (more information on page 23).



DESIGN THINKING INFLUENCING THINKING WITH FURNITURE

With ACTA.PRO, you can create agile working islands in the middle of an open space office – a strategy that actively influences the way teams think. To achieve this, choose bench seating, acoustic fleece screens, cupboard modules and flexible sliding whiteboards for the individual system components. Have it just the way you want. You have absolute freedom with regard to layout and colour scheme.

Products:
ACTA.PRO, NET.WORK.PLACE stools, side tables, PUBLICA bar stool, meeting tables

A BACKGROUND PICTURE WITH ADDITIONAL FUNCTIONS

A modular shelf system offers maximum flexibility for your space concepts.

Because the shelf can be configured both as a free-standing solution and against the wall, its appeal will remain as strong in the future as it is now. In a classy black finish with wooden inserts, locker modules and planters, ACTA.PRO combines elegant looks with exceptional functionality. It creates a stylish backdrop for good dialogue – face to face or via video link.



A GOOD LOOK FOR VIDEO MEETINGS

A wall in an intense colour such as dark blue, photo wallpaper or an attractive interior decor make ideal backgrounds for a video meeting. Avoid busy environments (for instance passers-by or untidiness) or a plain light- coloured wall. It makes delegates look pale and looks less professional.

IS ORDER ESSENTIAL FOR CREATIVITY?

The idea of creative chaos has been refuted time and time again. **In actual fact, order promotes creativity:** Tidying up, in other words establishing systematic order, is the crucial step towards creative problem-solving. Give your brain some help with clearing up and treat yourself – and your team – to a structured, inspiring environment.



THERE'S MORE THAN ONE VARIETY OF ORDER

Monotonous order: rigid, uniform, closed, controlling, fixed, sterile

Creative order: playful, open, with plenty of scope and variety – this can easily become reality with ACTA.PRO



Products:
ACTA.PRO, TALO.YOU One, QUICK.III, CUBIX.A and NET.WORK.PLACE Wave armchair



Products:
ACTA.PRO, ASTRA, NET.WORK.PLACE Wave armchairs

WORKPLACES CHANGE. SO DOES OUR SHELF.

The most sustainable office outfitting is one that stays with you in the long term. **For temporary work, lobbies or coworking spaces, you can use features like allocated lockers, desk modules, pinnable PET felt and planters to create ACTA.PRO configurations** – which can be reconfigured again and again as required. ACTA.PRO is easy to put together, frames come in the classic colours of black and white – as well as accent colours yellow gold, ant red, quartz green and dull turquoise.

FANCY A COFFEE OR TEA – OR A NEW IDEA?

Office work thrives on casual, informal encounters, spontaneous dialogue and social interaction. And that's most likely to happen here: right where the action is. **Use ACTA.PRO to zone your open space. It ensures seclusion and privacy.** And you can add your own home comforts.



ACTA.PRO feels even homelier in the round tube design with fleece elements, wooden inserts and planters. Furniture in the **NET.WORK.PLACE** Wave series takes up the organic, biophilic theme in both form and materials.

Products:
ACTA.PRO, NET.WORK.PLACE Wave armchairs and sofa,
NET.WORK.PLACE stools, side tables and MOVE.MIX bar stools

YOU CAN BROADEN YOUR HORIZONS HERE – AND MORE!

Libraries serve as an inspiration to many people. Maybe because they're jam-packed with knowledge – and full of opportunities too. We've borrowed a few ideas from here for ACTA.PRO. **The shelf system allows unlimited expansion and extension.** There are planters, seating islands and fleece surfaces to give you almost infinite design potential – plus some fantastic additional features like the catering trolley.



Products:
ACTA.PRO, NET.WORK.PLACE Wave armchairs and side tables

**Do we need new people
for New Work?
We don't think so.
We need new opportunities.
And new ways to express
the traditional areas
of expertise.**

ACTA.PRO

ONE SYSTEM – COUNTLESS OPTIONS

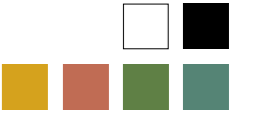

DESIGNER PLANTER
In various sizes in an organic design, to improve the indoor climate.

FLEECE
Made from recycled PET in a choice of light grey or dark grey.



ACRYLIC GLASS
Available in transparent white, green and orange.



SHELF CONNECTION
In various designs.

SHELVES AND CARCASSES
Choose from standard wood-effect designs and colours to match the frame.



SLIDING FRONTS
Felt made from recycled PET, pinnable and used for visual screening, expanded metal or whiteboard for workshops and agile working scenarios.



FRAME
The shelf frame comes in a square or round tube design, as well as a variety of colours.

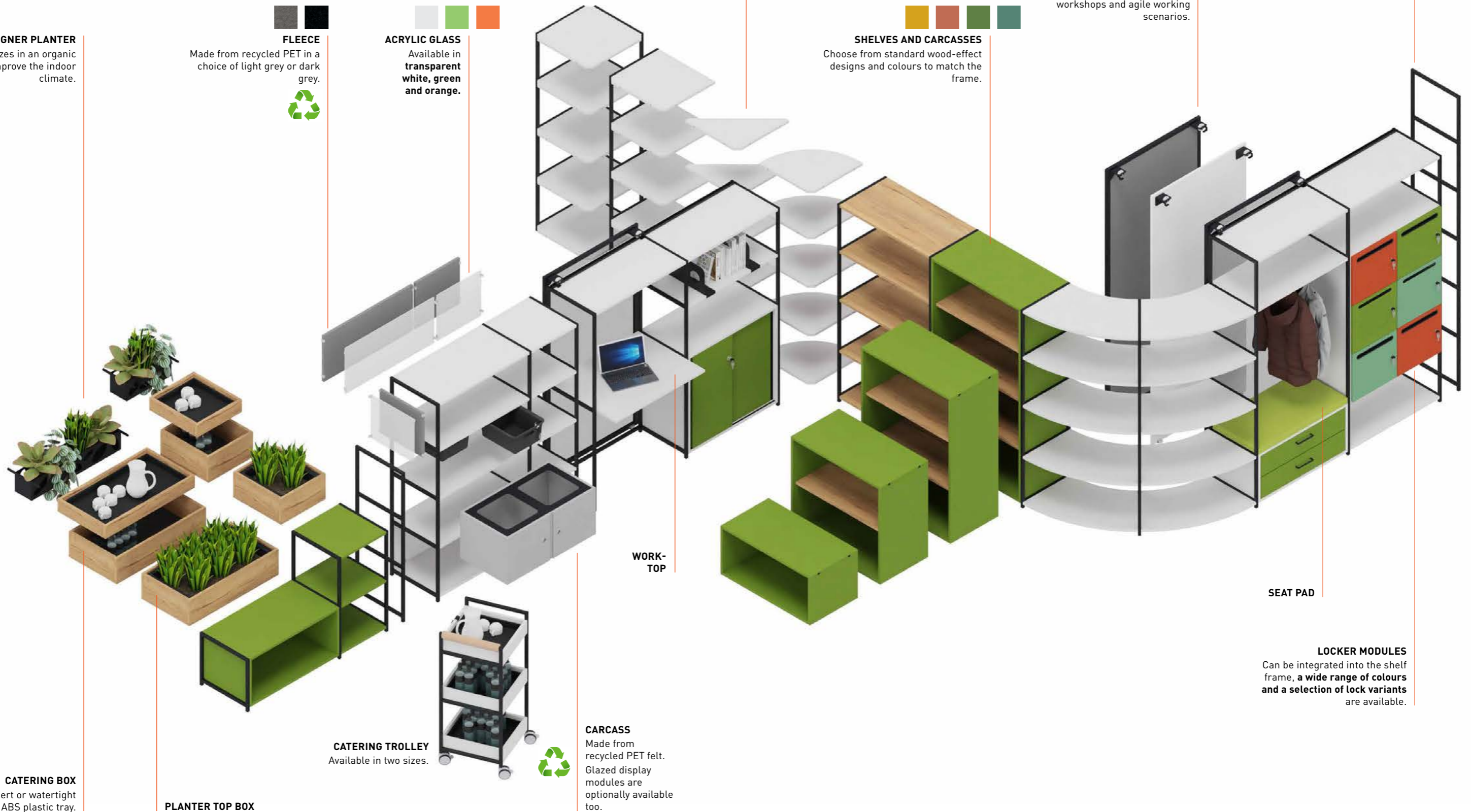

CATERING BOX
With felt insert or watertight ABS plastic tray.

PLANTER TOP BOX

CATERING TROLLEY
Available in two sizes.



CARCASS
Made from recycled PET felt. Glazed display modules are optionally available too.



WORK-TOP

SEAT PAD

LOCKER MODULES
Can be integrated into the shelf frame, a wide range of colours and a selection of lock variants are available.

DETAILS

1 | FRAMES

With square or round tube frame for flexible space zoning.



2 | BOOKEND

Made from steel plate, slots onto shelves or reinforcement modules, with variable width depending on requirement.



3 | INFILLS

Made from recycled PET felt or coloured acrylic glass, tool-free clip-in fitting in variable configurations. Mix and match materials according to preference.



4 | CLOSED HINGED DOOR ELEMENT

Made from PET fleece, practical single-part design that can be fitted between two ladders. Openings facilitate handling.



5 | STORAGE BOX

Made from PET felt, with variable positioning options, can either be fitted under a shelf or alternatively placed directly on the shelf. Optionally lockable.



6 | PLANTER

With integral plastic tray.



7

7 | CLICK-CONNECTION TECHNOLOGY

To connect ladders and crosspieces.

THE SYSTEM THAT CLICKS TOGETHER

The straightforward click system makes assembly and dismantling quick and easy. Shelves and cupboard carcasses are simply bolted onto the crosspieces.

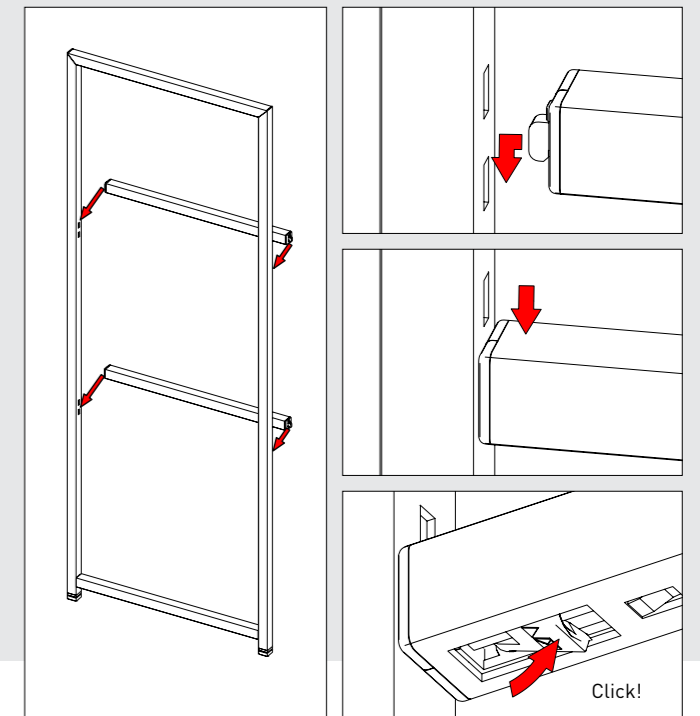

8



8

8 | SUPPLEMENTARY ADD-ONS

Variable position sliding front with whiteboard surface, with expanded metal for a transparent look, or with clip-on PET felt (not shown).



9

9 | CATERING TROLLEY

Mobile and versatile. The shelf elements have a felt insert, or alternatively plastic trays can be used. A cork-covered handle makes the trolley easy to move around on its braked castors.

DETAILS AND MATERIALS



The free-standing shelving combination provides storage, partitioning and structure. It can be supplied with **coloured acrylic glass** or **sustainable PET felt**. Other features include a **lockable bar cabinet** with downward opening flipper door and a smoothly **sliding rear panel made from powder-coated expanded metal**.



Our **shelving combination with lockers** provides flexible storage. The melamine-faced carcasses are easy to fit between the ladder frames, and can be removed and repositioned again as required. The locker modules are available in various heights: 1 FH, 2 FH, 3 FH and 4 FH.



















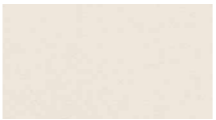



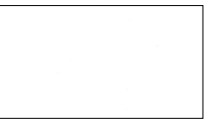











Whether you need **height transitions, space zoning for a corner configuration, or versatile outfitting options with cupboard modules**, with ACTA.PRO you have unlimited flexible planning and configuration potential.

FINISHES

COLOUR MFC (LACQUERED) FOR FRONTS

	
RAL0909030 Wax yellow	RAL0806070 Yellow gold
	
RAL2408005 Misty blue	RAL2303020 Teal dark blue
	
RAL0109005 Rose cream	RAL0203030 Crystal dark red
	
RAL1409005 Rosemary white	RAL1404020 Acacia green
	
RAL1008080 March green	RAL0858085 Decor yellow
	
RAL2804045 Hyacinth blue	RAL1805015 Dull turquoise
	
RAL3504050 Madder red	RAL0405040 Ant red
	
RAL1607045 Garish green	RAL1205030 Quartz green
	
	RAL2004 Pure orange

SURFACE FINISHES

MFC SOLID COLOUR	MFC WOOD EFFECT	TREND COLLECTION	FENIX	POW-DER-COATED METAL	TEXTURED FINISH
					
GK Grey	AA Acacia	9L Oak Halifax	7V Fenix black	AL Aluminium coloured	KSS Black
					
GW Off-white	AO Maple	9T Beige	7M Fenix white	AM Anthracite metallic	WIS Pure white
					
KH Light grey	ET Oak natural	9R Medium grey	7J Fenix dark grey	KS Black RAL 9011	TREND COLLECTION
					
KT Aluminium coloured	MB Beech	GX Yellow gold	7I Fenix dark beige	PK Metal clear varnish	RAL0806070 Yellow gold
					
MA Anthracite		AR Ant red		WI Pure white	RAL0405040 Ant red
					
WI Pure white		QG Quartz green			RAL1205030 Quartz green
					
SC Black		SF Dull turquoise			RAL1805015 Dull turquoise

Subject to technical and programme alterations, printing and other errors. Printed colours may vary from actual colours.

SYSTEM OVERVIEW

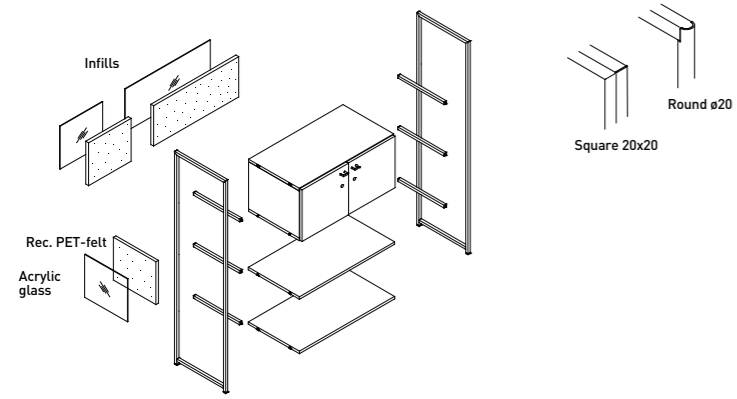

Types of shelves



Types of corner shelf

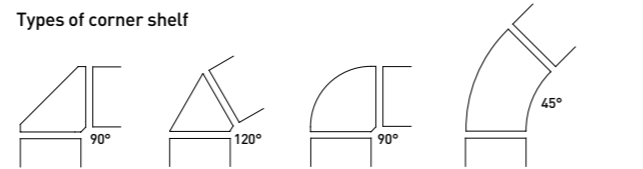

L-configuration T-configuration X-configuration Y-configuration

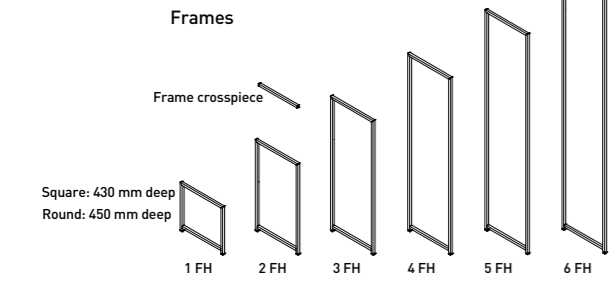
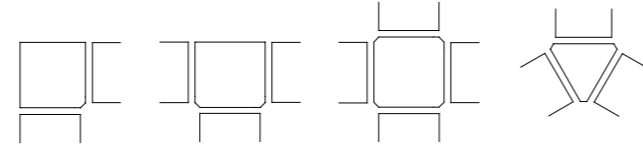

Sliding fronts

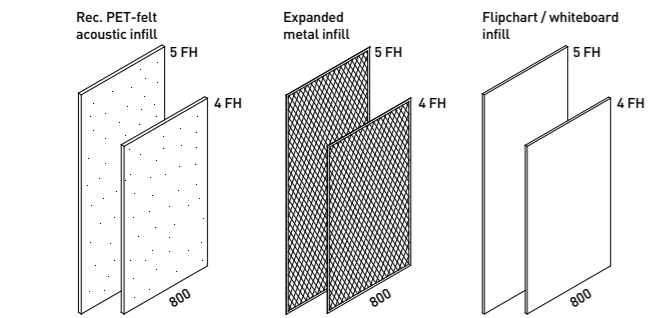

Types of carcass

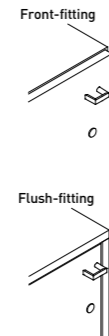
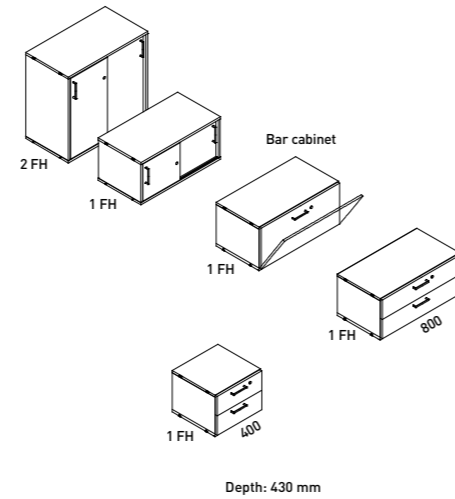

Accessories

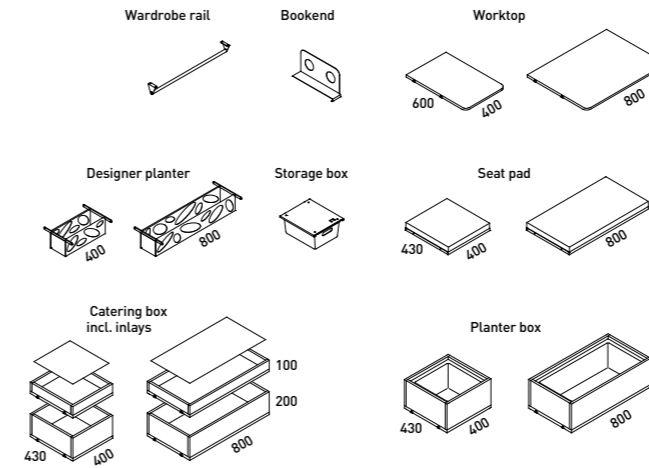

MODULARITY
Multifunctional elements can be configured individually and are easy to rearrange.

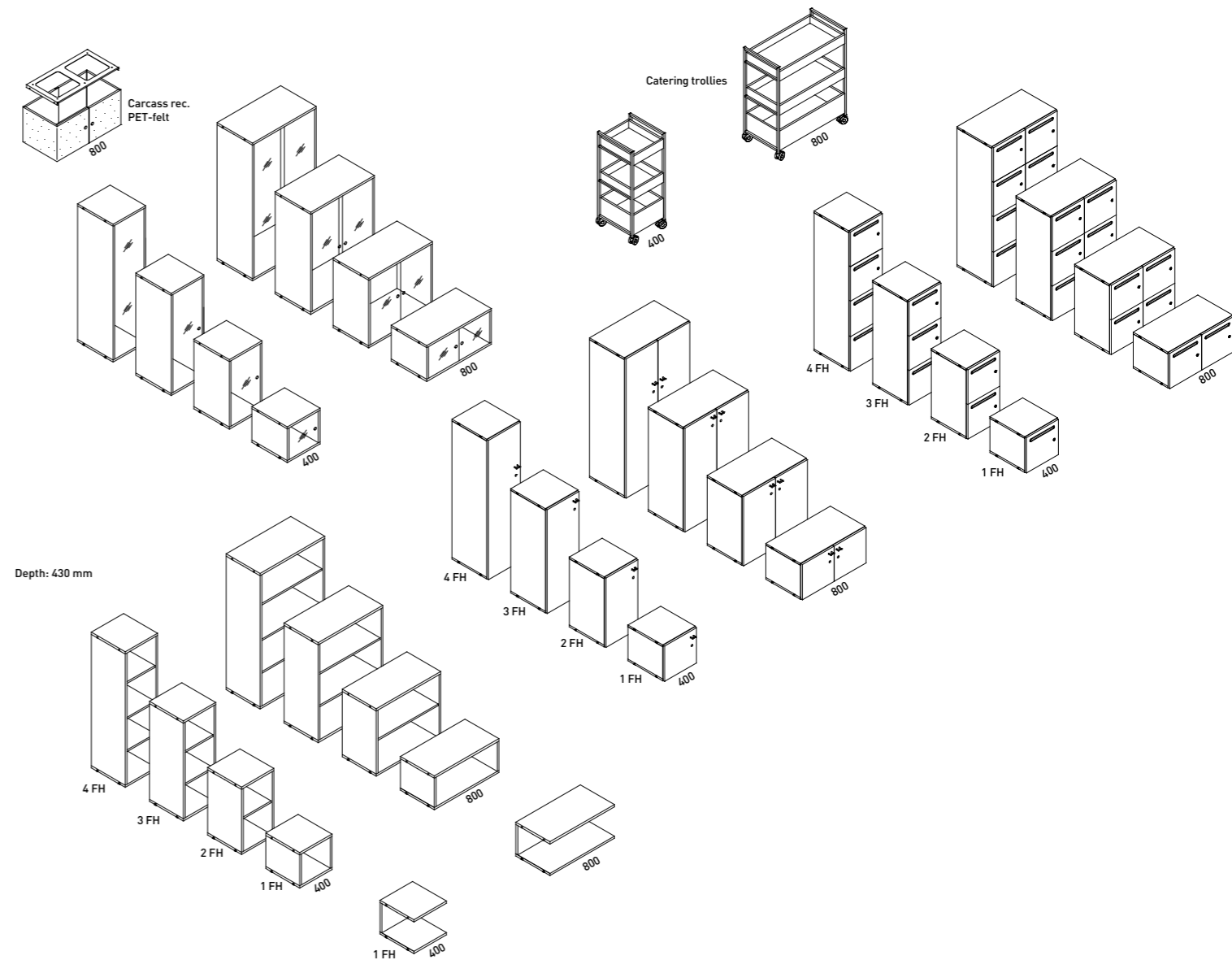

PRODUCT OVERVIEW

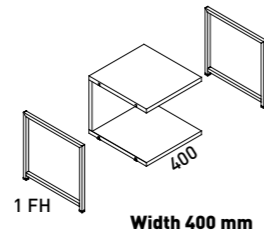

Width 400 mm

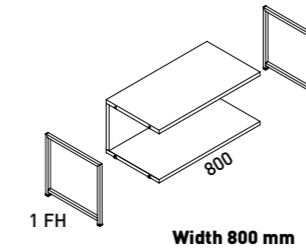

Width 800 mm

Description

Frames/Metal / Design square/round Welded steel frame with square or round cross-section on adjustable glides, with crosspieces

Dimensions

Height incl. adjustable feet	1 FH – 405 mm	2 FH – 780 mm	3 FH – 1,155 mm
	4 FH – 1,530 mm	5 FH – 1,905 mm	6 FH – 2,280 mm
Width	400 mm		
System depths:	Square design 430 mm	Round design 450 mm	

Modules

Reinforcement back panel	■
Shelf	19 mm, depth 430 mm
Worktop depth 600 mm	
Catering box incl. inlays	■
Shelf module for seat cushion	■
Planter shelf	■

Shelf types for changing direction

90° rounded shelf	465 x 465 mm
Shelf for L-configuration	465 x 465 mm
Shelf for T-configuration	500 x 465 mm
Shelf for X-configuration	500 x 500 mm
Shelf for Y-configuration	60° trilateral insert

Infills:

Felt sides and back panel	■
Plexiglass sides and back panel	■
PET sides and back panel	■

Cupboard module / carcass types

Shelf	1 FH – 4 FH
Hinged door cupboard	1 FH – 4 FH
Locker	1 FH – 4 FH
Glass cabinet	1 FH – 4 FH
Sliding door cupboard	
Double drawer	1 FH
Bar cabinet (with flipper door)	

Add-on sections, sliding front

Expanded metal	
Whiteboard	

Accessories

Seat pad	■
Wardrobe rail	■
Designer planter	■
Bookend	□
Planter box	■
Storage box	■
Bar cabinet (with flipper door)	□

Catering trolley

Mobile on castors, with cork handle, Height 1,009 mm	■
--	---

Welded steel frame with square or round cross-section on adjustable glides, with crosspieces

1 FH – 405 mm	2 FH – 780 mm	3 FH – 1,155 mm
4 FH – 1,530 mm	5 FH – 1,905 mm	6 FH – 2,280 mm
800 mm		
Square design 430 mm	Round design 450 mm	

■
19 mm, depth 430 mm
■
■
■
■

465 x 465 mm
465 x 465 mm
500 x 465 mm
500 x 500 mm
60° trilateral insert

■
■
■

1 FH – 4 FH
1 FH – 4 FH
1 FH – 4 FH
1 FH – 4 FH
1 FH, 2 FH
1 FH
1 FH

■
■

■
■
■
□
■
■
□

■

■ Standard □ Optional



As a leading brand for office furniture and room systems, König + Neurath develops solutions for individual work cultures



NET.WORK.PLACE Wave
Homely soft seating programme with endless possibilities –
The new art of sitting!



CUBIX.A
Wooden modules for creative working environments.



QUICK.III
Stand in style.



INSIDE.30
Optimising spaces acoustically. With a system.



TALO.YOU One
Single-column workstation –
small, flexible, mobile!



Together with specialist retailers, König + Neurath supports its customers throughout the entire process of outfitting offices. With differentiated style collections, design-conscious furniture and digital solutions, the family-owned company, established in 1925, helps its customers to adapt successfully to the changing nature of the workplace.

Deutschland

König + Neurath AG
Industriestraße 1-3
61184 Karben
T +49 6039 483-0
info@koenig-neurath.de

Great Britain

König + Neurath (UK) Ltd.
Ground and Lower Ground Floor
75 Farringdon Road
London EC1M 3JY
T +44 20 74909340
info@koenig-neurath.co.uk

Nederland

König + Neurath Nederland
Beethovenstraat 530
1082 PR Amsterdam
T +31 20 4109410
info@konig-neurath.nl

France

König + Neurath AG
53, rue de Châteaudun
75009 Paris
T +33 1 44632393
info@koenig-neurath.fr

Schweiz

König + Neurath (Schweiz) GmbH
St. Gallerstrasse 106 d
CH-9032 Engelburg / St. Gallen
T +41 52 7702242
info@koenig-neurath.de

Österreich

König + Neurath AG
Gonzagagasse 1 / Morzinplatz
1010 Wien
T +43 676 4117512
info@koenig-neurath.de

