

# TABLE.H + ACTA.MODUL

**A HOMELIER FEEL –  
WORKING WITH ALL THE SENSES**



interior  
innovation  
award  
2015

Winner

FOR TABLE.H

IC 0 2  
N I C 0  
A W A 1  
R D S 6

INTERIOR  
INNOVATION

winner

FOR ACTA.MODUL

KÖNIG +  
NEURATH

# Wood creates a natural homely feel – not just at home

Wood is a prized natural product with a character all of its own. Colour and structure are different every time – each piece is unique. We are fascinated by its natural diversity and durability. That's why we only use veneers from sustainably-managed forests for our products. Crafting the hand-selected veneers is a challenging task for which the wood technicians must apply expertise in fine detail. The combination of skilled craftsmanship and state-of-the-art production technology is the perfect starting point for office furniture with true character. Wood looks good anywhere, bringing warmth into a room – be it the management office or a space in which the working style is open, creative and goal-driven. The thing is, you need more than a desk, chair and shelf to create a working environment that inspires.



Cornelius Müller-Schellhorn



STORAGE SYSTEM  
IDEAL FOR ANY  
ROOM SCENARIO



Use colour highlights  
to introduce your own  
individual office style.



“K+N Design is characterised by  
its outstanding serviceability –  
good design is usage-oriented.”  
  
C. Müller-Schellhorn  
Head of K+N Design



# EVERYONE HAS A DIFFERENT WORKING STYLE – *EFFECTIVE IS THE BEST*

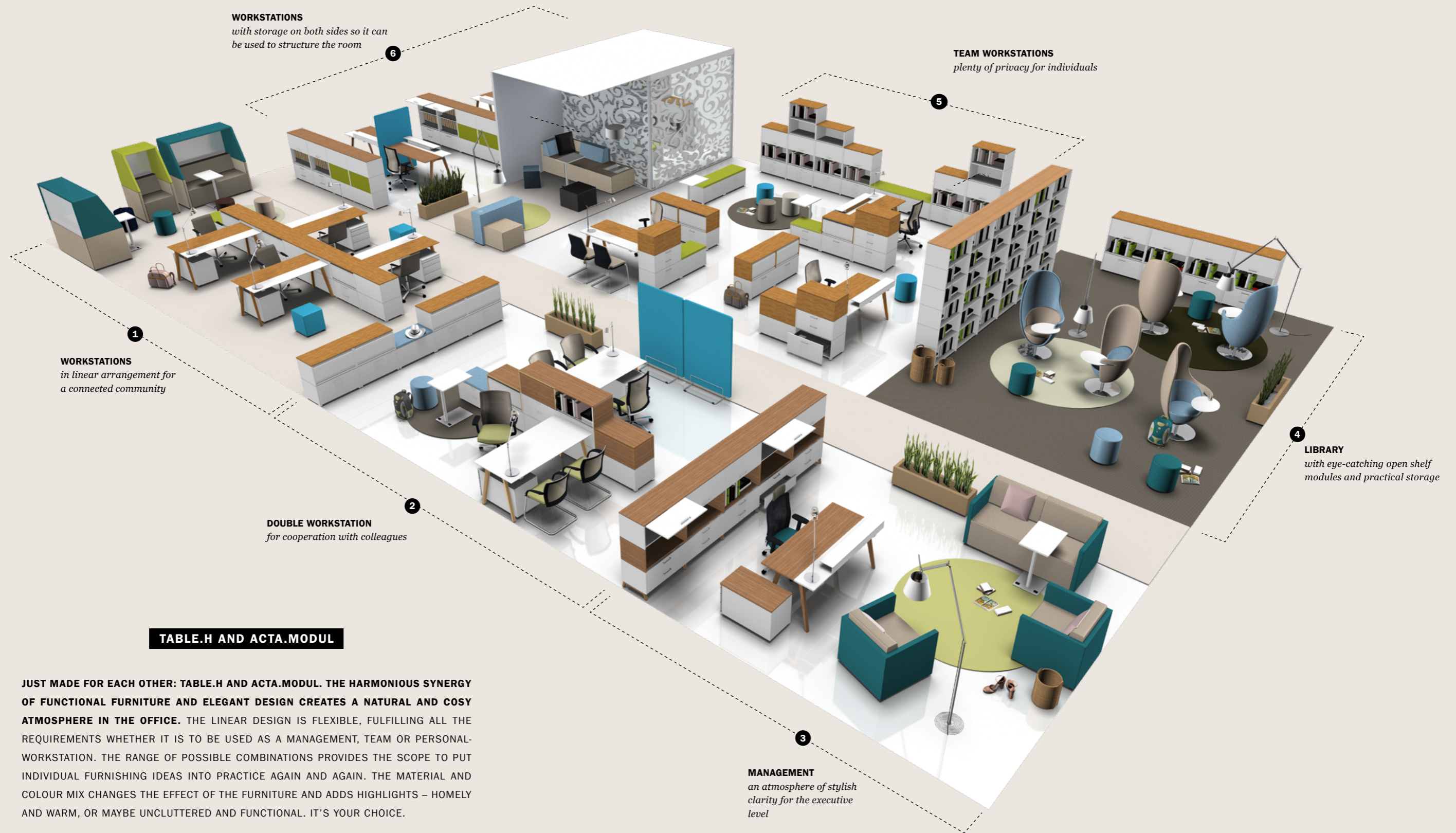

**WORKSTATIONS**  
with storage on both sides so it can  
be used to structure the room

**TEAM WORKSTATIONS**  
plenty of privacy for individuals

**WORKSTATIONS**  
in linear arrangement for  
a connected community

**DOUBLE WORKSTATION**  
for cooperation with colleagues

**LIBRARY**  
with eye-catching open shelf  
modules and practical storage

## TABLE.H AND ACTA.MODUL

JUST MADE FOR EACH OTHER: TABLE.H AND ACTA.MODUL. THE HARMONIOUS SYNERGY OF FUNCTIONAL FURNITURE AND ELEGANT DESIGN CREATES A NATURAL AND COSY ATMOSPHERE IN THE OFFICE. THE LINEAR DESIGN IS FLEXIBLE, FULFILLING ALL THE REQUIREMENTS WHETHER IT IS TO BE USED AS A MANAGEMENT, TEAM OR PERSONAL-WORKSTATION. THE RANGE OF POSSIBLE COMBINATIONS PROVIDES THE SCOPE TO PUT INDIVIDUAL FURNISHING IDEAS INTO PRACTICE AGAIN AND AGAIN. THE MATERIAL AND COLOUR MIX CHANGES THE EFFECT OF THE FURNITURE AND ADDS HIGHLIGHTS – HOMEY AND WARM, OR MAYBE UNCLUTTERED AND FUNCTIONAL. IT'S YOUR CHOICE.

**MANAGEMENT**  
an atmosphere of stylish  
clarity for the executive  
level



# REPRESENTATIVE *WORKING*

---

**TABLE.H IS DESIGNED AS AN ELEGANT EYE-CATCHER IN WALNUT, AND IT FORMS A REPRESENTATIVE WORKSTATION FOR THE MANAGEMENT LEVEL YET DOES NOT COMPROMISE ON LIGHTNESS AND ELEGANCE. THE MINIMALIST DESIGN FOCUSES ON ESSENTIALS, SINCE ALL SUPERFLUOUS DETAILS ARE ELIMINATED WITH THIS CONCEPT. IT'S JUST THE JOB FOR PLANNING STRATEGY, TAKING RESPONSIBILITY, REACHING CRITICAL DECISIONS OR DELEGATING TASKS.**

---

**PRODUCTS:**  
TABLE.H, ACTA.MODUL with wooden feet,  
OKAY.II, pedestal, NET.WORK.PLACE single-seater

# DISCOVER YOUR *FAVOURITE DESK*



---

**TABLE.H'S PURIST, MINIMALIST STYLE CREATES A COSY ATMOSPHERE IN THE OFFICE, WHICH PROMOTES THE CREATIVITY OF EMPLOYEES. IT COMBINES WELL WITH THE MODULAR STORAGE COMPONENTS TO PROVIDE OPTIMUM CONDITIONS FOR CONCENTRATED SOLITARY WORK OR TEAM SITUATIONS. EVEN TEDIOUS TASKS CAN BE COMPLETED FASTER IN AN INSPIRING WORK ENVIRONMENT. TABLE.H IS A STATEMENT ABOUT INDIVIDUALITY AND PERSONAL STYLE.**

---

**PRODUCTS:**  
TABLE.H, ACTA.MODUL with chrome feet, NET.WORK.PLACE stool and side tables, JET.II task chair and visitor chairs

# IRRESISTIBLY NATURAL

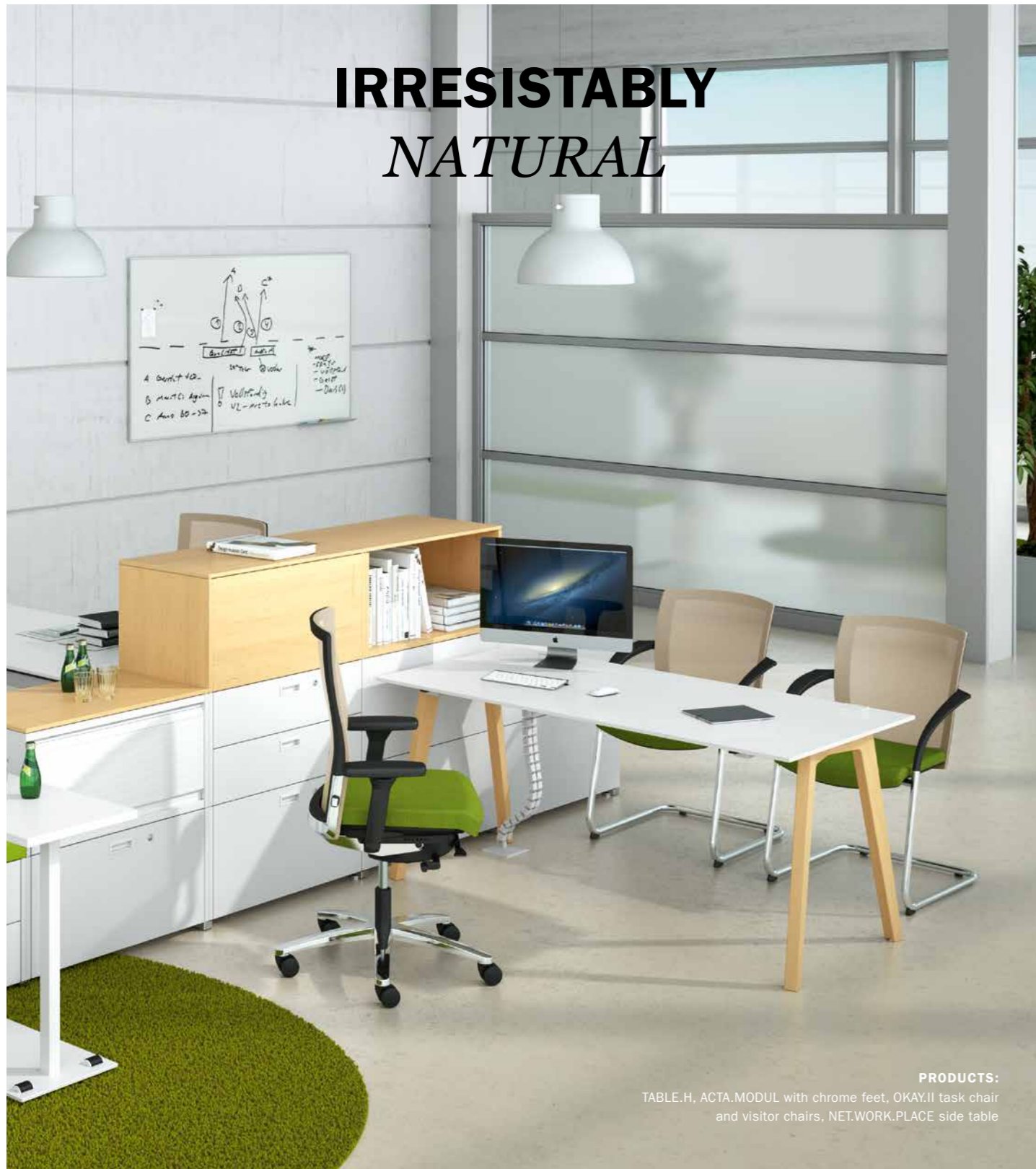

PRODUCTS:  
TABLE.H, ACTA.MODUL with chrome feet, OKAY.II task chair  
and visitor chairs, NETWORK.PLACE side table

WE HAVE SELECTED THREE TYPES OF WOOD TO REALLY BRING OUT THE NATURAL BEAUTY IN THE NEW TABLE.H PROGRAMME: MAPLE FOR A MODERN NORDIC LOOK, OAK FOR NATURAL DURABILITY AND WALNUT RADIATING PURE ELEGANCE FOR REPRESENTATIVE AREAS. ALTERNATIVELY THERE ARE CLEAR MELAMINE FINISHES IN PURE WHITE, LIGHT GREY OR UNI MELANGE.

## ALL OPTIONS ARE TOP QUALITY

Three veneers, elegant looks



# OPEN FOR NEW RELEASES *AND ADDITIONS*



## STABILITY

Two modules are linked with one foot using the patented connection technology.



REFRESHINGLY MINIMALIST AND WITH CLEAR-LINED FUNCTIONALITY, THIS SHELF UNIT CONSISTS OF OPEN ACTA.MODUL ELEMENTS TO MEET EVERY REQUIREMENT OF A MODERN AND PRACTICAL BOOKSHELF. COFFEE-TABLE BOOKS, DICTIONARIES, LITERATURE CLASSICS OR DECORATIVE HOME ACCESSORIES ARE ALL EQUALLY AT HOME HERE. RELAX IN A NET.WORK.PLACE LOUNGE CHAIR AND ACHIEVE THAT IN-FLIGHT EXPERIENCE BY ENJOYING A BOOK IN THE READING CORNER OR FOYER.

PRODUCTS:  
NET.WORK.PLACE LOUNGE CHAIR, ACTA.MODUL with chrome feet

# INDIVIDUAL STORAGE FOR *ALL NEEDS*



**PRODUCTS:**  
TABLE.H, ACTA.MODUL with chrome feet, OKAY.II task chair,  
TEAM.WORK.SPACE screens

---

**MINIMAL DESIGN: MAXIMUM MODULAR-DIVERSITY STORAGE IS CHILD'S PLAY THANKS TO FLIPPER DOORS AND VERTICAL TAMBOUR FRONTS FOR A CLOSED STORAGE UNIT, DRAWERS FOR RAPID ACCESS, OR OPEN SHELVES FOR EASY ORGANISATION. THE MODULES CAN BE ROTATED TO PROVIDE THE REQUIRED WORKSTATION-BASED STORAGE WHILST BRINGING STRUCTURE INTO THE ROOM. THANKS TO THE PATENTED, TOOL-FREE CONNECTION TECHNOLOGY THE MODULES ARE EASY TO STACK, CAN BE COMBINED IN MANY DIFFERENT WAYS AND ASSEMBLED QUICKLY. ALL THESE FEATURES HELP TO ALLOW PLANNERS EXTRAORDINARY DESIGN FLEXIBILITY.**

---



**FLIPPER DOOR**  
*for efficient use of space and clear gangways*



**LOCKABLE DRAWER**  
*for storing important personal documents*



# MODULAR AND DIVERSE – ACTA.MODUL

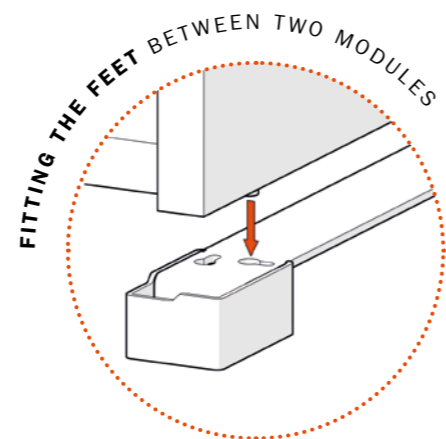
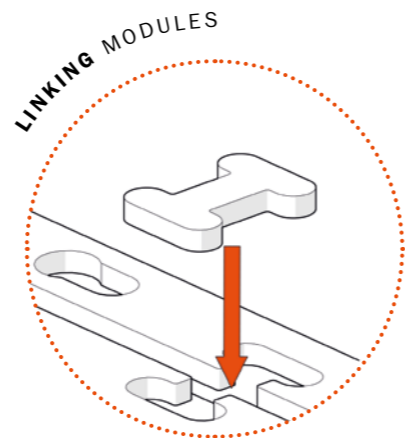
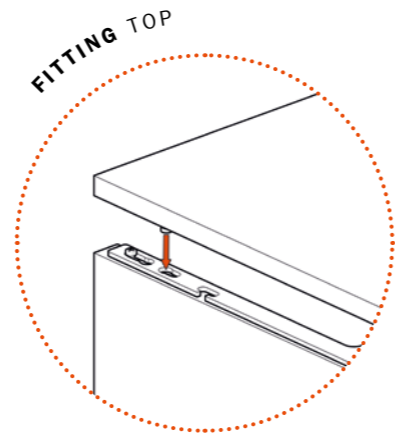

**SHELF UNIT** rotates through 180°, ideal workstation storage with access from either side; can also be used as a room divider

# INSPIRATIONAL FRONT AND HANDLE STYLES

Combine to suit your mood



Wall fixings are needed if module exceeds 5 FL in height



FLAT BAR HANDLE



D HANDLE  
rectangular section



BOW HANDLE  
round section



ROUND HANDLE  
rectangular section



RECESSED HANDLE

# Pure elegance for individual requirements



### PERSONAL UTENSILS

The stacking module provides space for your favourite pen, personal documents and other bits and pieces.



**SPLIT SLIDING TOP**  
The electric unit is accessible for easy cabling.

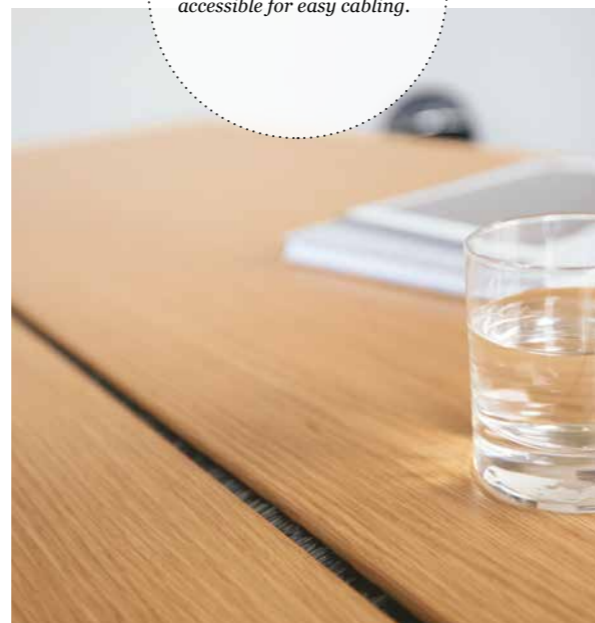

K+N FABRIC VARIETY FOR MORE ATMOSPHERE

**LITTLE DETAILS MAKE THE DIFFERENCE, GIVING THE OFFICE A CONTEMPORARY LOOK.** OUR FABRIC COLLECTIONS AND FINISHES CAN BE MIXED AND MATCHED IN COUNTLESS WAYS, SO YOU CAN CREATE DIFFERENT EFFECTS WITH YOUR OFFICE FURNITURE AND PRODUCE CUSTOMISED COLOUR SCHEMES.

# Choose your finish

MELAMINE SOLID COLOUR	MELAMINE PATTERNED	veneER	COLOUR	POWDER-COATED METAL
GK Grey	AA Acacia	AH Canadian maple natural	3B Blue RAL Design 2803040	AL Alu coloured
GW Off-white	AO Maple	BB Pear	3C Green RAL Design 1604040	AM Anthracite metallic
KH Light grey	ET Oak natural	BH Beech natural	3D Light blue RAL Design 2405020	GC Chrome
KT Alu coloured	MB Beech	BO Beech chocolate stained	3E Orange RAL Design 0505070	GK Grey
MA Anthracite	NK Walnut	BU Beech light stained	3F Light green RAL Design 0956060	GW Off-white
UM Melange	UL Elm	BZ Beech anthracite stained	3G Yellow RAL Design 0708060	KH Light grey
WI Pure white	CK American cherry	SN American walnut natural	3R Red RAL Design 0304050	KS Black
	EH Oak light stained	WS Ash white stained	YB Basalt grey RAL 7012	MA Anthracite
				WI Pure white

### Finishes for the TABLE.H top

We cannot be held liable for technical modifications, printing errors and changes to the product range.

# Outstanding aesthetics

## TABLE.H

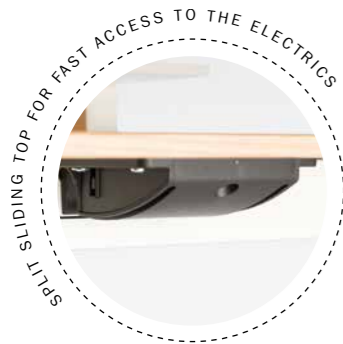

- 1 | HIGH-QUALITY**  
Based on a professional and functional construction platform.
- 2 | ELEGANT**  
Slim wooden legs complement the classy, linear design.
- 3 | CONNECTABLE**  
Pre-installed sockets provide power.
- 4 | PRACTICAL**  
The drawer insert offers storage space for office utensils.

# Little details, big effect

## ACTA.MODUL

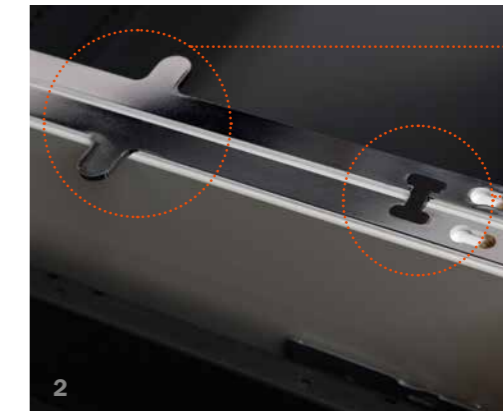

FOR VERTICAL CONNECTIONS

FOR HORIZONTAL CONNECTIONS



- 1 | WELL-DESIGNED**  
The flipper door opens into the shelf unit saving space.
- 2 | PATENTED**  
Tool-free horizontal and vertical connection technology for straight-forward module linking.
- 3 | FUNCTIONAL**  
Modular construction means it can be positioned and used either way round as well as allowing flexible and free-standing configurations.
- 4 | COMFORTABLE**  
Cushioned seat is tempting for a quick chat.
- 5 | CONNECTING**  
The feet can be fitted centrally to link two modules. Ideal in combination with the TABLE.H desking system.
- 6 | STURDY**  
High-quality glides in chrome or solid wood ensure stability.

# Overview of elements

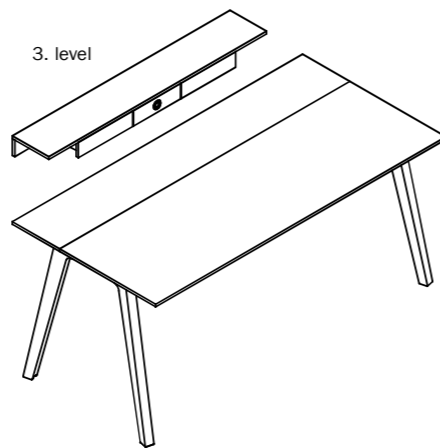
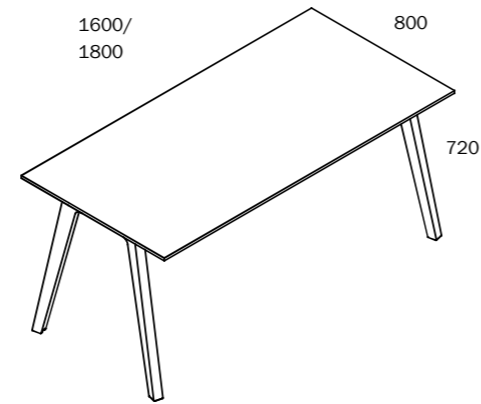
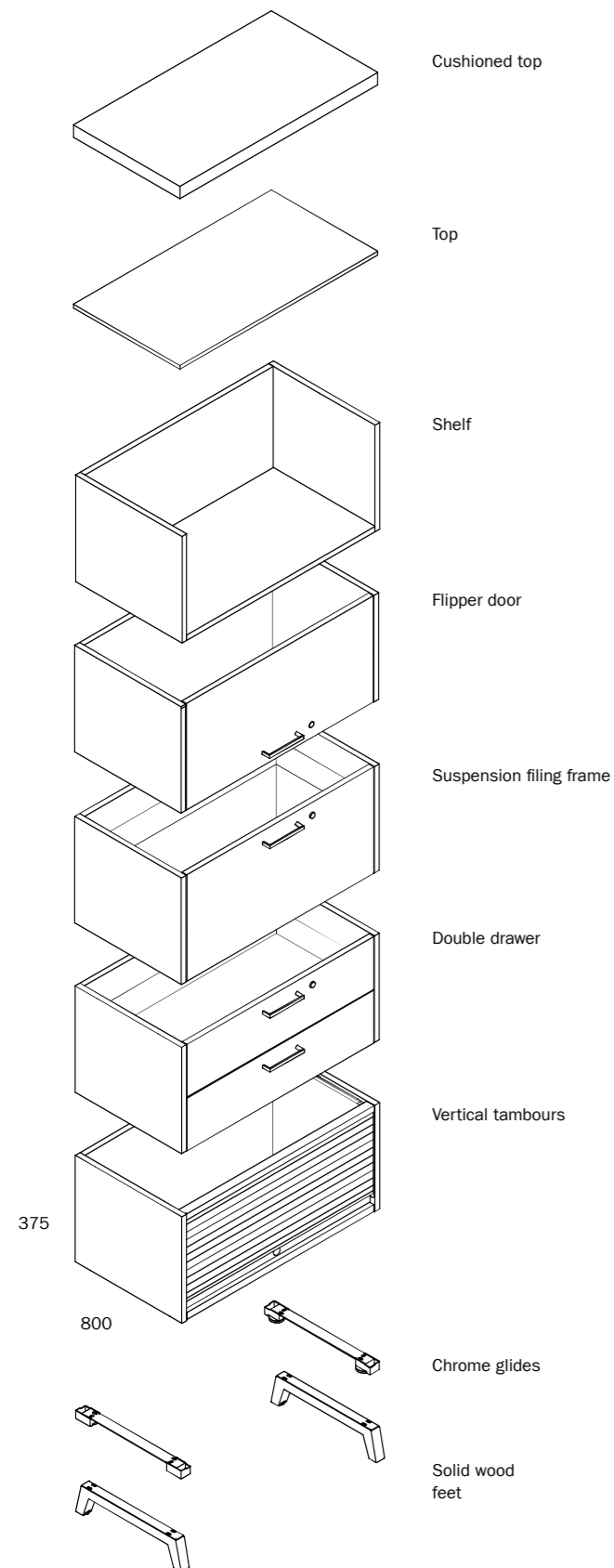

# ACTA.MODUL

## Cabinet modules

Modular elements without top shelf	•
Top	•
Vertical module connector chrome	•
Horizontal module connector	○

## Dimensions

Height: 1 FL<sup>1</sup> (375 mm)  
**Height grid without glides or solid wood feet:**  
 375 mm (1 FL<sup>1</sup>), 750 mm (2 FL<sup>1</sup>), 1125 mm (3 FL<sup>1</sup>),  
 1500 mm (4 FL<sup>1</sup>), 1875 mm (5 FL<sup>1</sup>), 2250 mm (6 FL<sup>1</sup>)  
**Height grid with glides or solid wood feet:**  
 405 mm (1 FL<sup>1</sup>), 780 mm (2 FL<sup>1</sup>), 1155 mm (3 FL<sup>1</sup>),  
 1530 mm (4 FL<sup>1</sup>), 1905 mm (5 FL<sup>1</sup>), 2280 mm (6 FL<sup>1</sup>)  
 Width: 800 mm, inside width 759 mm  
 Depth: 430 mm

## Models

Shelf	•
Flipper door	•
Pull-out with suspension filing frame	•
Double drawer	•
Vertical tambour with profile handle	•

## Finishes

Melamine - plastic	•
Colour	•
Veneer	•

## Handles

D handle, rectangular section	•
Bow handle, round section	○
Round handle, rectangular section	○
Flat bar handle	○
Recessed handle	○

## Locking

Locking front	•
---------------	---

## Accessories

Cushioned top	○
Pedestal set-glides	○
Pedestal set-wooden feet	○
Dividers for double drawers	○

• Standard ○ Option <sup>1</sup> FL = filing level

# TABLE.H

## Frame

A-frame solid wood	•
--------------------	---

## Dimensions

Widths	1600 mm, 1800 mm	•
Depths	800 mm	•

## Height adjustment

Fixed	720 mm (13 mm top)	•
-------	--------------------	---

## Worktops

Wooden composite top with décor finish	13 mm fixed (across whole top)	•
	13 mm split sliding top (basic top and extension can be selected separately)	○
Wooden composite top with veneer finish	13 mm fixed (across whole top)	○
	13 mm split sliding top (basic top and extension can be selected separately)	○

## Add-ons

3rd level	Drawer add-on	○
-----------	---------------	---

## Side sections

	Solid wood maple, oak	•
	Solid wood, walnut	○

## Electrics

Horizontal	Cable tray central + 3-gang socket + mains lead 3500 mm	○
Vertical	Cable chain	○

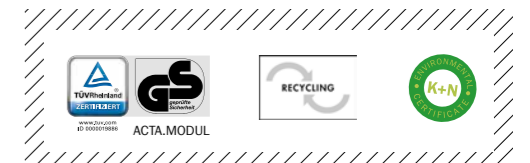

**Deutschland**

König + Neurath AG  
Büromöbel-Systeme  
Industriestraße 1-3  
61184 Karben  
Tel.: +49 (0)6039 483-0  
Fax: +49 (0)6039 483-214  
e-mail: [info@koenig-neurath.de](mailto:info@koenig-neurath.de)  
[www.koenig-neurath.de](http://www.koenig-neurath.de)

**Great Britain**

K + N International  
(Office Systems) Ltd  
52 Britton Street  
London EC1M 5UQ  
Tel.: +44 (0)20 74909340  
Fax: +44 (0)20 74909349  
e-mail: [info@koenig-neurath.co.uk](mailto:info@koenig-neurath.co.uk)  
[www.koenig-neurath.co.uk](http://www.koenig-neurath.co.uk)

**Nederland**

König + Neurath Nederland  
Office Furniture  
Airport Business Park Lijnden  
Frankfurtstraat 18+22  
1175 RH Lijnden  
Tel.: +31 (0)20 4109410  
Fax: +31 (0)20 4109419  
e-mail: [info@konig-neurath.nl](mailto:info@konig-neurath.nl)  
[www.konig-neurath.nl](http://www.konig-neurath.nl)

**France**

König + Neurath AG  
Showroom Paris  
66, rue de la Victoire  
75009 Paris  
Tel.: +33 (0)1 44 63 23 93  
Fax: +33 (0)1 44 63 23 97  
e-mail: [info@koenig-neurath.fr](mailto:info@koenig-neurath.fr)  
[www.koenig-neurath.fr](http://www.koenig-neurath.fr)

**Schweiz**

König + Neurath (Schweiz) GmbH  
Büromöbel-Systeme  
St. Gallerstrasse 106 d  
9032 Engelburg / St. Gallen  
Tel.: +41 (0)52 770 22 42  
e-mail: [info@koenig-neurath.de](mailto:info@koenig-neurath.de)  
[www.koenig-neurath.de](http://www.koenig-neurath.de)