

OMNI MES

Macro ES Homogenizer USER MANUAL



OMNI
INTERNATIONAL

The Homogenizer Company™

REV. B
03-216

WARRANTY INFORMATION

This manual is a guide for the use of the Omni Macro ES Homogenizer and accessories.

Data herein has been verified and validated. It is believed adequate for the intended use of the instrument. If the instrument or procedures are used for purposes over and above the capabilities specified herein, confirmation of the validity and suitability should be obtained, otherwise Omni International does not guarantee results and assumes no obligation or liability. This publication is not a license to operate under, or a recommendation to infringe upon, any process patents.

Notes, cautions, and warnings within the text of this manual are used to emphasize important and critical instructions.

This Omni International product is warranted to be free from defects in material and workmanship for a period of ONE YEAR from the date of delivery. Omni International will repair or replace and return free of charge any part which is returned to its factory within said period, transportation prepaid by user, and which is found upon inspection to have been defective in materials or workmanship. For the first 90 days, both parts and service are without charge. For the balance of the period, parts will be provided but service will be charged at established labor rates. This warranty does not include normal wear from use; it does not apply to any instrument or parts which have been altered by anyone other than an employee of Omni International nor to any instrument which has been damaged through accident, negligence, failure to follow operating instructions, the use of electric currents or circuits other than those specified on the plate affixed to the instrument, misuse, or abuse. Omni International reserves the right to change, alter, modify, or improve any of its instruments without any obligation whatever to make corresponding changes to any instrument previously sold or shipped.

THE FORGOING OBLIGATION IS IN LIEU OF ALL OBLIGATIONS AND LIABILITIES INCLUDING NEGLIGENCE AND ALL WARRANTIES OF MERCHANTABILITY OR OTHERWISE, EXPRESSED OR IMPLIED IN FACT OR BY LAW, AND STATE OUR ENTIRE AND EXCLUSIVE LIABILITY AND BUYERS EXCLUSIVE REMEDY FOR ANY CLAIM OF DAMAGES IN CONNECTION WITH THE SALE OR FURNISHING OF GOODS OR PARTS, THEIR DESIGN, SUITABILITY FOR USE, INSTALLATION, OR OPERATION. OMNI INTERNATIONAL WILL IN NO EVENT BE LIABLE FOR ANY SPECIAL OR CONSEQUENTIAL DAMAGES WHATSOEVER, AND THEIR LIABILITY UNDER NO CIRCUMSTANCES WILL EXCEED THE CONTRACT PRICE FOR THE GOODS FOR WHICH LIABILITY IS CLAIMED.

IMPORTANT SAFEGUARDS

- READ ALL INSTRUCTIONS BEFORE USING.
- SAVE THIS OWNER'S MANUAL.

The Omni Macro ES has been engineered for economical functionality as well as safety; however, basic safety precautions and common sense must always be demonstrated when using any electrical product.

DO NOT attempt to modify any part of the Omni Macro ES. If you experience problems with or have questions about your Omni Macro ES, contact your authorized dealer or call Omni International at 800-776-4431 or 770-421-0058.

DANGER

- **DO NOT** allow the machine to be submerged in any liquid.
- **DO NOT** use in any setting other than an indoor laboratory.
- **DO NOT** plug power cord into an incorrect outlet.

WARNING

To reduce the risk of burns, electrocution, fire, or injury:

- Use this product only for its intended purpose as described in this booklet. **DO NOT** use attachments not recommended by the manufacturer.
- **DO NOT** operate the product if it is damaged in any way.
- Keep this product away from heated surfaces.

TABLE OF CONTENTS

Warranty Information	2
Section 1 — Omni MES, Macro ES Homogenizer	
1.1 Specifications	5
1.2 Parts	6
1.3 Assembly	7
1.4 Motor Support Stand	9
1.5 Quick Connect Coupling Assembly	11
1.6 Optional Automated Motor Support Stand	11
1.7 Theory of Operation—Homogenization Controls	12
1.8 Variable Speed and Variable Time Operation	12
1.9 Programmability	13
1.10 Circuit Breaker	17
1.11 External Speed Verification	17
Section 2 — Motor Unit Maintenance	
2.1 Rotor-Stator Generator Probes	18
2.2 Installing Generator Probes	18
2.3 Operation	19
2.4 Vessel Restraint Disk	19
Section 3 — Sealed Chamber Assemblies	
3.1 Sealed Chamber Assemblies	20
3.2 Using Sealed Blade Chamber Assemblies	20
3.3 Sealed Generator Probe Chamber Assemblies	22
3.4 Installing Sealed Chamber Assemblies	22
Section 4 — Dispersating and Impeller Accessories	
4.1 Dispersating Probe Accessories	23
4.2 Dispersion Impeller Accessories	23
Section 5 — Motor Unit Maintenance	
5.1 Motor Drive Unit	24
5.2 Removal of Quick Connect Coupling	24
5.3 Motor Brush Maintenance	24
5.4 Bearings and Lubrication	24
5.5 Grounding Instructions	25
Section 6 — Troubleshooting	26
Section 7 — Explosion Drawings and Part Lists	
7.1 Omni Macro ES 115V/220V	27
Section 8 — Service	
8.1 Assistance	29
8.2 Decontamination	29

SECTION 1 — Omni MES, MACRO ES HOMOGENIZER

The Omni Macro ES Homogenizer is a variable speed, post-mounted homogenizer. The Omni Macro ES is powered by a 1,800 watt, 20,000 rpm motor. It includes a built-in high efficiency speed control, a digital speed display, a built-in timer and a broad choice of sealed chamber assemblies, high shear knife assemblies, and a choice of nine different diameter autoclavable rotor-stator generator probes. The motor drive unit housing has been specifically designed to reduce motor noise to less than 68db at top speed. The versatility of this unit is unparalleled and makes them ideal general purpose laboratory and small batch homogenizers. The accuracy ensures repeatable and scaleable results for critical experimentation and preprocess development work. They are ideally suited for laboratory automation, short run pilot scale production, and production scale up development.

1.1 SPECIFICATIONS

Variable Motor Speed: 1,000-20,000 rpm

Speed Control Accuracy: 0.5%

Height (with stand): 34.5 in.

Weight (with stand): 32 lbs. (14.5kg.)

Electrical Requirements:

115V, 60Hz or 220V, 50Hz

Standards Approval/Compliance:







220V: CE Certified

1.2 PARTS AND ACCESSORIES

Prior to operation, please remove all parts from the shipping container and inspect for damaged or missing parts. If any parts are found to be damaged or missing, please contact Omni International at 1-800-776-4431. The basic Omni Macro ES consists of the following:

Description	Part Number	Quantity
Motor Drive Unit (115V)	1800DS-1	1
OR		
Motor Drive Unit (220V)	1800DS-1	1
Instruction Manual	03-216	1
Stand Assembly	LT500	1
Quick Connect Coupling Assembly	17210	1
Quick Connect Adapter	17204	1 (3 w/ MES Package)
Generator Probe Adapter	15001	1 (4 w/ MES Package)

The following components are supplied as part of the Omni Macro ES Tool Kit (P/N 17104):

	Description	Part Number	Quantity
	Gen Probe Multi Tool	00-402	2
	20, 32, 35, 45, 55mm Knife Tool	15100K	1
	1/16" Allen Wrench	00-416	1
	5/64" Allen Wrench	60027	1
	3/32" Allen Wrench	60128	1
	1/8" Allen Wrench	60241	1
	5/32" Allen Wrench	737	1
	5/16" x 5/8" Combo Wrench	60033	1
	5mm Lower Bearing Press	59105	1
	7mm Lower Bearing Press	59107	1
	Lubricant	61971	1

1.3 ASSEMBLY

Use the following instructions to assemble the Omni and Stand Unit.



1. Make sure you have all the necessary parts: a) MES motor assembly, b) post, c) threaded knob, d) base plate assembly, e) Allen wrench, & f) 3 screws (provided).



2. Attach the base plate to the post with the provided screws and Allen wrench.

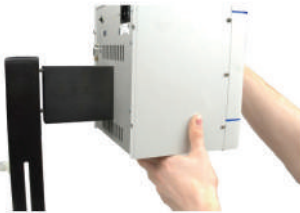

3. Place the MES motor unit onto the post. Align the dowel pins on the MES motor unit with the small pair of holes in the post.



4. Seat the MES motor unit fully against the post before adding the Threaded Knob.



5. Insert the Threaded Knob into the hole through the back of the post. Turn the knob until the motor unit is securely attached to the post. Hand tighten only.

SECTION 1 — Omni MES, MACRO ES HOMOGENIZER



6. Raise the Movable Platform to the desired level and secure it with the positioning knob as shown.



7. Attach the power cord to the rear of the motor unit as shown.



8. The unit is now ready for operation.

1.4 MOTOR SUPPORT STAND

The Motor Drive Unit of the Omni Macro ES must be assembled to the Motor Support Post by means of the Motor Support Knob before the unit is ready to operate.

The depth of the generator probe in the sample vessel is adjusted by means of the Moveable Platform and can significantly affect flow patterns and therefore processing efficiency.

CAUTION: To avoid product damage, never ship the Motor Drive Unit while assembled to the Motor Support Post.

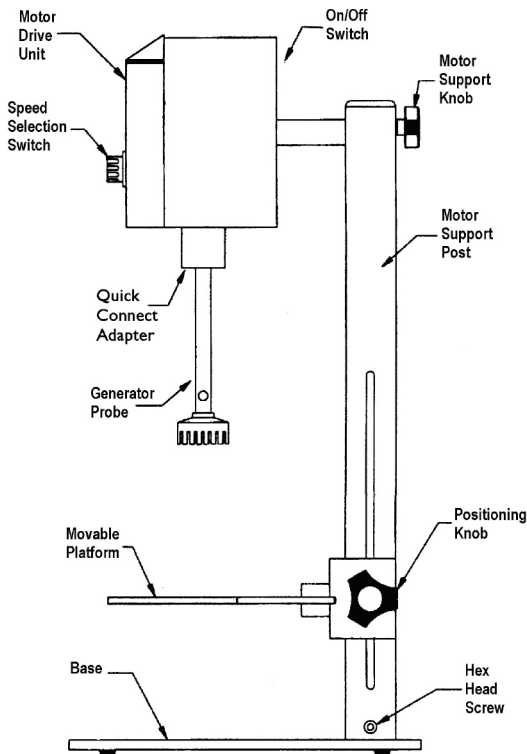

SECTION 1 — Omni MES, MACRO ES HOMOGENIZER

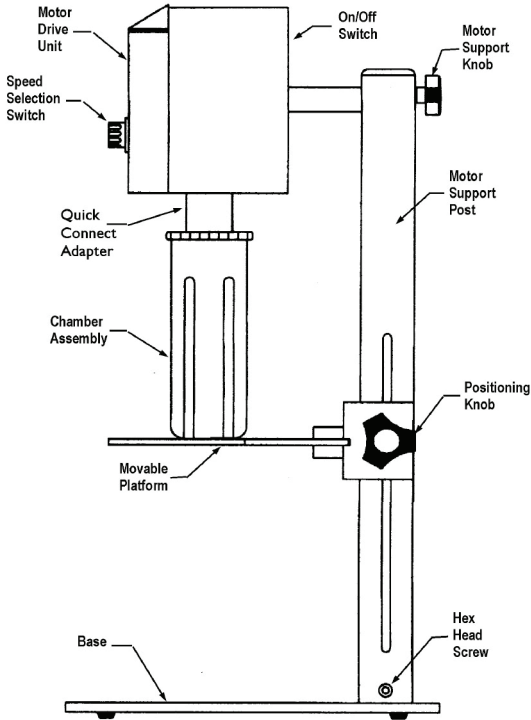

WARNING: When using sealed chamber assemblies, the bottom of the chamber assembly must rest on the moveable platform. This prevents the chamber assembly from disengaging from the motor, which could expose rotating blades, and could lead to a broken seal.

CAUTION: To prevent damage to the drive mechanism, never operate the motor without a sealed chamber assembly or generator probe installed.

NOTE: If you experience excessive vibration, heat, or bearing wear, please contact technical support at 1-800-776-4431

1.5 QUICK CONNECT COUPLING ASSEMBLY

The Quick Connect Coupling Assembly comes standard on the Omni Macro ES. To use, attach a Quick Connect Adapter to your chamber assembly or generator probe (See Section 2 for more information). Next, slide the Adapter into the Quick Connect Coupling and a retaining ring positions into place for a secure hold. To disconnect, simply slide the ring upward and the processing accessory is conveniently released.



17210 Quick Connect
Coupling Assembly

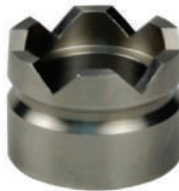

17204 Quick Connect
Adapter

CAUTION: Never operate the motor with the generator probe or sealed chamber assembly partially attached to the Quick Connect Coupling Assembly. To prevent damage to the motor and attachments, follow the instructions in Section 2.2 to assure the generator probe or sealed chamber assembly, Section 3.4 is fully connected to the Quick Connect Coupling Adapter.

1.6 OPTIONAL AUTOMATED MOTOR SUPPORT STAND

An automated stand (PN 82010) can be substituted or retrofitted in place of the standard motor stand assembly (PN LT-500). This is a factory installed option, since the motor drive unit must be modified to accommodate the automated stand controls. Upward and downward motion is controlled by the control switch located on the lower right side of the face plate. The speed of travel of the automated stand can be adjusted by means of a screw driver adjustment potentiometer located at the back of the motor drive unit.

1.7 THEORY OF OPERATION—HOMOGENIZER CONTROLS

The Macro ES is controlled and programmed by means of an encoder input (called control knob) working in conjunction with an alpha-numeric LCD display screen. The control knob serves two functions, selecting screens, and selecting parameters within each screen. In the screen selection mode, turning the control knob moves the operator from the SPEED to the TIME screens. When a desired screen is displayed, depressing the control knob allows the operator to change to the screen parameter selection mode. In this mode, turning the control knob clockwise increases the screen parameter value (such as TIME or SPEED), while turning the control knob counter-clockwise decreases the value. Once screen parameters have been selected, pressing the control knob again changes its function back to the screen selection mode.

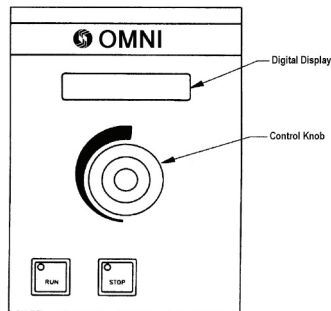

1.8 VARIABLE SPEED AND VARIABLE TIME OPERATION

Speed and the operating time may be pre-selected and regulated to achieve optimum results when working with different materials, and will remain programmed for future operation, until reprogrammed by the operator.

Speed Selection: Turn on POWER to display the last selected speed. Push and release the control knob. To increase speed, turn the control knob clockwise, or reduce speed by turning the control knob counter-clockwise.

NOTE: Sample viscosity and generator probe size may reduce top speed attained for a given sample.

HOLD (Unlimited) Time Selection: Once speed has been selected, the Omni Macro ES can be operated for an indefinite period of time by pressing RUN. To terminate a run, press STOP.

Timed Run Operation: Select speed, then select run time by pushing and releasing the control knob, then rotating the control knob to display the time selection window.

SECTION 1 — Omni MES, MACRO ES HOMOGENIZER

The last selected run time will be displayed. Push the control knob to enter the time selection window 0:00:00, which displays hours, minutes (flashing), and seconds. Turn the control knob until the desired run time (minutes) has been entered, then push and release the control knob to select the run time (seconds), and finally the run time (hours). When the desired run times have been entered, the unit can be started by pressing RUN.

Display During Operation: During operation, RUN SPEED will be displayed, as well as TIME REMAINING.

Example: To operate the homogenizer at a speed of 12,500 RPM for 2 minutes and 30 seconds, or for an indefinite time (HOLD):

POWER ON

SPEED=1,000RPM
MAX SPEED=20,000

When **POWER** is turned on, the green **RUN** button and the red **STOP** button will alternately flash while the homogenizer performs a brief diagnostic program. The display will show the most recently selected run parameters.

SETTING RUN SPEED

SPEED=12,500RPM
MAX SPEED=20,000

Push and release the control knob. The speed display will flash. Turn the control knob clockwise to increase speed to 12,500. Push and release the control knob again and the display speed will stop flashing.

SETTING RUN TIME

TIME=0:02:30

Turn the control knob clockwise until timer window appears. Push and release the control knob, the minute segment of the hour:minute:second display will flash. Turn the control knob until the minute display reads 2 minutes. Push and release the control knob again and the seconds display will flash. Turn the control knob until the display reads 30 seconds. Push the control knob twice, then press **RUN** to operate at 12,500 RPM for 2 minutes and 30 seconds.

SETTING RUN TIME

TIME=0:00:00
HOLD=00:00:00

Follow the procedure above for setting Run Time until all three time segments have been set to 0 as shown to the left.

HOLD

TIMER=HOLD
HOLD=00:00:00

Push and release the control knob and the display will read **HOLD**. Push **RUN** to operate the program. Push **STOP** to end the program.

1.9 PROGRAMMABILITY

The Omni Macro ES is configured with on board programmability. Up to twelve programs with twelve individual steps per program may be entered and stored in the units computer.

Programming:

To program, turn the control knob until the PRESET PROGRAMS window appears. Push and release the control knob for a choice of PROGRAM 1 through PROGRAM 12. To enter the desired program, push and release the control knob. A new window with four addressable sections will appear:

- If PROGRAM 1 is chosen, the first section will be P01/01, where P01 equals Program 1 and 01 equals segment 1 of program 1. If PROGRAM 2 is chosen, this section will show P02/01, etc. . .
- Push and release the control knob to display one of three choices, RAMP TO (ramps speed to a chosen speed and time setting), SPEED (speed and time selection), or END PRG (to end programming). Turn the control knob to find a choice and push and release the control knob to make a choice and move into the next window segment.
- Once programming has been completed, choose END PRG (End Programming) by pushing and releasing the control knob when END PRG flashes. A new window called EXIT VIEW MODE appears. Push and release the control knob to access to Programs 1 through 12, as well as EXIT PROGRAM MODE. Choose a Program number to enter additional programs or choose EXIT PROGRAM MODE to return to manual operation.

Operating a Program:

- Turn the control knob until the PRESET PROGRAMS window appears.
- Push and release the control knob and PROGRAM 1 appears. Turn the control knob to choose PROGRAM 1 through PROGRAM 12, then press the RUN button and the unit will operate as programmed.

SECTION 1 — Omni MES, MACRO ES HOMOGENIZER

Example: To create a program to ramp the operating speed of the homogenizer from 0 RPM to 10,000 RPM in 2 minutes, then run the homogenizer at 10,000 RPM for 30 seconds, then run the unit at 15,000 RPM for 1 minute and then to ramp from 15,000 RPM to 1,000 RPM in 2 minutes requires 5 program segments as follows:

POWER ON

SPEED=**1,000**RPM
MAX SPEED=20,000

Turn on **POWER** and the green **RUN** button and the red **STOP** button will alternately flash on and off while the unit performs a brief diagnostic program. The display will show the most recently selected run parameters.

PROGRAMMING

PRESET PROGRAMS

Turn the control knob clockwise until the PRESET PROGRAMS window appears. Push and release the control knob.

PROGRAM 1

PROGRAM 1

Turn the control knob to access Programs 1 through 12. For this example, choose PROGRAM 1 by pushing the control knob.

SET PROGRAM SEGMENT

P01/**01** SPEED
0000 00:00

Push and release the control knob to select the flashing segment 01 display. P01 signifies program 1 and /01 signifies program segment 1.

SETTING SPEED

P01/01 **RAMP TO**
10,000 00:00

Turn the control knob clockwise until the flashing segment reads RAMP TO. Push and release the control knob.

SETTING SPEED

P01/01 RAMP TO
10,000 00:00

Turn the control knob until the flashing segment reads 10,000. Push and release the control knob.

SETTING TIME

P01/01 RAMP TO
10,000 **02:00**

Turn the control knob until the flashing seconds segment reads 00:00. Push and release the control knob. Turn the control knob until the flashing minute segment reads **02:00**. Push and release the control knob.

SECTION 1 — Omni MES, MACRO ES HOMOGENIZER

SET PROG. SEGMENT 02

P01/02 END PROGRAM
0000 00:00

Turn the control knob to select the flashing segment 02 display. P01 signifies program 1 and /02 signifies program segment 2.

SETTING SPEED MODE

P01/02 **SPEED**
10,000 00:00

Turn the control knob clockwise until the flashing segment reads SPEED. Push and release the control knob.

SETTING SPEED

P01/01 SPEED
10,000 00:00

Turn the control knob until the flashing segment reads 10,000. Push and release the control knob.

SETTING TIME

P01/01 SPEED
0000 00:**30**

Turn the control knob until the flashing seconds segment reads 00:30. Push and release the control knob. Turn the control knob until the flashing minute segment reads 00:30.

SET PROG. SEGMENT 03

P01/03 END PROGRAM
0000 00:00

Turn the control knob to select the flashing segment 03 display. P01 signifies program 1 and /03 signifies program segment 3.

SETTING SPEED MODE

P01/03 **SPEED**
0000 00:00

Turn the control knob clockwise until the flashing segment reads SPEED. Push and release the control knob.

SETTING SPEED

P01/03 SPEED
15,000 00:00

Turn the control knob until the flashing segment reads 15000. Push and release the control knob.

SETTING TIME

P01/03 SPEED
15,000 **01:00**

Turn the control knob until the flashing seconds segment reads 00:00. Push and release the control knob. Turn the control knob until the flashing minute segment reads 01:00.

SET PROG. SEGMENT 04

P01/04 END PROGRAM
0000 00:00

Turn the control knob to select the flashing segment 04 display. P01 signifies program 1 and /04 signifies program segment 4.

SECTION 1 — Omni MES, MACRO ES HOMOGENIZER

SETTING RAMP MODE

P01/04 **RAMP TO**
0000 00:00

Turn the control knob clockwise until the flashing segment reads RAMP TO. Push and release the control knob.

SETTING SPEED

P01/02 SPEED
500 00:00

Turn the control knob until the flashing segment reads 500. Push and release the control knob.

SETTING TIME

P01/04 SPEED
500 **02:00**

Turn the control knob until the flashing seconds segment reads 00:00. Push and release the control knob. Turn the control knob until the flashing minute segment reads 02:00.

SET PROG. SEGMENT 05

P01/05 END PROGRAM
0000 00:00

Turn the control knob to select the flashing segment 05 display. P01 signifies program 1 and 05 signifies program segment 5.

END PROGRAM MODE

P01/05 **END PROGRAM**
0000 00:00

Turn the control knob clockwise until the flashing segment reads END PROGRAM. Push and release the control knob.

EXIT PROGRAM MODE **EXIT VIEW MODE**

The display now reads EXIT VIEW MODE. Push and release the control knob.

OPERATING PROGRAM 1 **PROGRAM 1**

The display now reads PROGRAM 1. To operate the program, push **RUN**. To select other preset programs, turn the control knob.

1.10 CIRCUIT BREAKER

In the event that the motor is overloaded during operation, the circuit breaker, located at the rear of the motor drive unit may trip, and can be easily reset.

1.11 EXTERNAL SPEED VERIFICATION

For independent speed verification of the speed display, remove the black plug from the top of the motor drive housing, and verify speed by means of a photo tachometer, reading directly from the top of the motor drive shaft.

SECTION 2 — ROTOR-STATOR GENERATOR PROBES

2.1 ROTOR-STATOR GENERATOR PROBES

Generator probes are available for use with the Omni Macro ES but are not supplied with the instrument. These probes can be used in a sealed chamber, or for added convenience, in an open vessel environment when aerosols or sample contamination are not a concern.

2.2 INSTALLING GENERATOR PROBES

All generator probes are easily installed to the motor unit by following these steps:

1. Screw the generator probe adapter PN 15001 into the Quick Connect adapter.
2. Screw the generator probe into the generator probe adapter.
3. Slide the retaining ring up on the Quick Connect Adapter.
4. Insert the Quick Connect Adapter into the Quick Connect Coupling Assembly and slide the retaining ring down to lock the generator probe in place (See diagram below).
5. Remove the blue protective cap from the tip of the generator probe and the homogenizer is ready to operate.

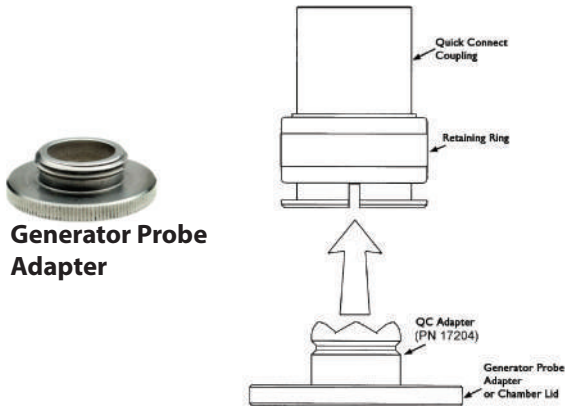

WARNING: The tip of the generator probe, especially on the saw tooth generator probes, is sharp. For safety purposes it is advisable that the protective cap be replaced on the generator probe when not in use.

CAUTION: The bottom of the generator probe is extremely fragile and care should be taken to protect it. Replace the blue protective cap on the end of the generator probe when the generator probe is not being used.

NOTE: If you experience excessive vibration, heat, or bearing wear, please contact technical support at 1-800-776-4431

2.3 OPERATION

Generator probes can be used in open containers or in sealed chamber assemblies. Sample processing efficiency is effected by:

- Amount of material processed vs. size and speed of the generator probe.
- Container geometry and size (round vessels encourage swirling, while fluted or cornered vessels disrupt flow patterns for more effective mixing/processing).
- Processing speed optimal speed.
- Size and type of material and flow characteristics (material particles must be small enough to be carried into the generator head for optimal processing)

To operate the generator probe simply remove the blue protective cap from the end of the generator probe. Keep the blue protective cap on the tip of the generator probe when the generator probe is not being used.

CAUTION: When using Teflon lower bearings, immerse the bottom of the generator probe in liquid or in the sample to avoid premature failure of the lower bearing.

WARNING: DO NOT process pathogenic material in an open container, since aerosols created during normal processing could be inhaled by the operator.

NOTE: Liquid circulates through the two holes in the generator probe. DO NOT block the upper hole, although the lower hole may be completely submerged during processing.

NOTE: For optimal sample recovery during processing, completely remove the generator probe from the sample prior to turning off the motor drive unit.

2.4 VESSEL RESTRAINT DISK (Optional)

The Vessel Restraint Disk (Part # LT-750) can be used with the Omni Macro ES to help reduce splashing and contain aerosols during homogenization. This accessory is compatible with 20mm and larger diameter rotor-stator generator probes and with containers up to six inches in diameter. The Vessel Restraint Disk also helps secure the container during processing.



NOTE: The Vessel Restraint Disk is not necessary when processing with sealed chamber assemblies.

SECTION 3 — SEALED CHAMBER ASSEMBLIES

3.1 SEALED CHAMBER ASSEMBLIES

Sealed chamber assemblies are available as separately ordered items for use with the Omni Macro ES. They consist of chambers, many of which are fluted to facilitate mixing by inhibiting swirling, gasket screw on cover seals to inhibit aerosol release, a shaft assembly, and a sharpened stainless steel blade, or generator probe. Chamber materials include stainless steel, glass, polycarbonate, and polypropylene. A full range of titanium chamber assemblies is also available for applications requiring protection from leached elemental components, or where additional strength is a factor. Please contact your nearest Omni International representative, or Omni International at 1-800-776-4431 for complete details.



3.2 USING BLADE CHAMBER ASSEMBLIES

Stainless Steel or Titanium - These chamber assemblies are intended for liquid and semi-solid materials. Homogenization and mixing will normally be completed within 30 seconds to one minute. For processing solid materials, first reduce particle size diameter to 1cm or less. Load the material to be processed in the chamber. Do not fill the chamber to full capacity. Processing of too much volume could force liquid up through the rotor shaft.

Glass and Plastic - These chamber assemblies are intended primarily for low-viscosity liquids or for light duty homogenization at speeds below 5,000 rpm. At speeds greater than 5,000 rpm, place glass jar into a secondary container for added protection.

WARNING: The maximum recommended speed when using any of the blade chamber assemblies is 10,000 rpm. Speeds in excess of 10,000 rpm can cause excessive bearing wear or part failure.

WARNING: Inspect glass or plastic chambers for any scratches or cracks, and do not use if any are found. Eye protection and utilization of a secondary container is recommended to prevent damage or injury in case of glass breakage.

SECTION 3 — SEALED CHAMBER ASSEMBLIES

Centrifugable - These assemblies are available in plastic or stainless steel, and should be used in the same manner as described for glass, plastic, and stainless steel above.

Breaking Down Specimen Particles - At speeds below 5,000 rpm, specimen particles may be broken down in the Omni Macro ES by using hard materials, such as glass beads. The Omni Macro ES will act as a “bead mill”, agitating the chamber while the hard materials do the work. Since sharpness is not essential, a dull blade should be used.

Homogenizing - For more complete homogenization of some materials, it may be helpful to rock the motor drive unit slightly during processing in order to churn up the specimen within the chamber.

WARNING: It is recommended that “bead mill” processing should not be undertaken in a glass vessel.

Adding a Grinding Medium - To attain the desired effect (cell breakdown) a combination of procedures may be useful. First homogenize the specimen in solution at maximum recommended speed (10,000rpm) with a sharp knife blade. Then change to a dull knife blade, add a grinding medium and run the homogenizer at 5,000 rpm for ten to fifteen minutes.

Using Generator Probes - To facilitate homogenization of some materials, it may be useful to pre-process the sample by using one of the techniques described above, and then completing the process by using a generator probe. Generator probes can achieve particle size reduction to less than 2 microns.

WARNING: When processing pathogenic material in a sealed container, carefully check seals and connections to be certain that they are not worn or leaking. A fume hood is recommended for processing pathogens, even with a sealed container.

WARNING: Knife blades are sharp. Handle carefully to avoid injury.

CAUTION: To prevent damage to the drive mechanism, *never* operate the motor without a sealed chamber assembly or generator probe installed.

CAUTION: Never operate the motor with the generator probe (or sealed chamber assembly) partially attached to the Quick Connect Adapter.

NOTE: If you experience excessive vibration, heat, or bearing wear, please contact technical support at 1-800-776-4431.

3.3 SEALED GENERATOR PROBE ASSEMBLIES

Sealed chamber generator probe assemblies are available for use with the Omni Macro ES but are not supplied with the instrument. They consist of chambers, many of which are fluted to facilitate mixing by inhibiting swirling, gasket screw on cover seals to inhibit aerosol release, and a generator assembly. Chamber materials include stainless steel, glass, polycarbonate, and polypropylene. A full range of titanium chamber assemblies is also available for applications requiring protection from leached elemental components, or where additional strength is a factor. Please contact Omni International at 1-800-776-4431 for complete details.

3.4 INSTALLING SEALED CHAMBER ASSEMBLIES

All chamber assemblies are easily installed to the motor unit by following these steps:

1. Screw Quick Connect adapter onto the top of the chamber assembly. Method of attachment is a left-handed screw thread.
2. Slide the retaining ring up on the Quick Connect Adapter.
3. Insert the Quick Connect Adapter into the Quick Connect Coupling Assembly and slide the retaining ring down to lock the chamber assembly in place (See diagram below).
4. Before operating, make certain that the chamber assembly rests securely on the moveable platform.

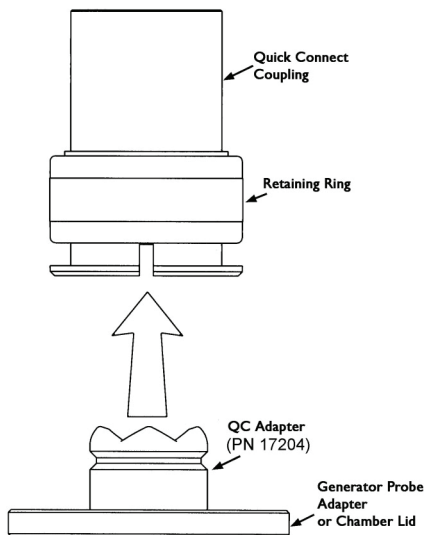

4.1 DISPERSATING PROBE ACCESSORIES

Dispersating probes are available for use with the Omni Mixer product line but are not supplied with the instrument. They are specifically designed for high speed and high shear mixing, dispersion and emulsifying. These probes provide less particle size reduction, but greater mixing options than the generator probes described in Section 2. They can be configured to draw material from either the top or the bottom of the processing vessel. They can be used in sealed chambers, or for added convenience, in an open vessel environment when aerosols or sample contamination are not a concern. Below is a list of standard available dispersating probes. An adapter, PN 15001 is required to operate probes outside of a sealed chamber. *Standard material is 316 stainless steel, however, all dispersating probes can be constructed from titanium in custom lengths or diameters as special order items.*

Description

25mm Dispersating Probe (195mm length)
25mm Dispersating Probe (195mm length)

Process

Bottom Drawing
Top Drawing

4.2 DISPERSION IMPELLER ACCESSORIES

Two inch diameter dispersion impeller blade accessories are available for the Omni Mixer product line but are not supplied with the instrument. They are specifically designed for dispersion, mixing and blending. These accessories can be used in sealed chambers, or for added convenience, in an open vessel environment when aerosols or sample contamination are not a concern. Below is a list of standard available dispersating probes. An adapter, PN 15001 is required to operate probes outside of a sealed chamber. *Standard material is 316 stainless steel, however, all dispersating probes can be constructed from titanium in custom lengths or diameters as special order items.*

Description

Clay Impeller
Rectangular Tooth Impeller
High Vane Impeller
High Turbulence Impeller

Process

High Shear Impeller
High Speed Dispersing
High Pumping/Mixing
High Viscosity

Impellers must be matched to the following Impeller Drive Assemblies:

Description

4" long drive assembly
6" long drive assembly
8" long drive assembly

5.1 MOTOR DRIVE UNIT

The motor drive housing can be cleaned periodically with a mild detergent. Never use solvents to clean the unit or accessories. While resistant to most laboratory chemicals, care should be taken to wipe off any concentrated and potentially damaging liquids.

Once per month the Quick Connect Coupling adapter (see diagram in Section 1.4) of the homogenizer should be removed and cleaned. After cleaning, a good lubricant should be applied to the threads.

5.2 REMOVAL OF QUICK CONNECT COUPLING ASSEMBLY

In the event that the motor drive connect and/or the flexible rubber coupling needs to be serviced or replaced, the Quick Connect coupling can be removed using the following procedure;

1. Unplug motor unit from the wall.
2. Insert flat edge of combination wrench (included in motor tool kit) into the slots of the Quick Connect coupling (see figure to right).
3. Using wrench for leverage, loosen Quick Connect coupling by twisting it counter-clockwise.

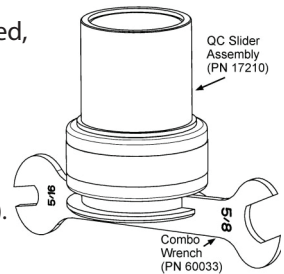

Installation of the coupling is the reverse of these steps.

5.3 MOTOR BRUSH MAINTENANCE

Omni Macro ES motors are not user serviceable and should be returned to the factory for brush replacement.

5.4 BEARINGS AND LUBRICATION

Motors are equipped with sealed ball bearings. Under normal use they require no additional lubrication. A tube of lubricant (PN 61971) is included with every drive unit and should be used to lubricate the threads of all connecting threaded parts, as well as the drive pin at the tip of the floating shaft (see Section 7.1). Lubricant should not be used to lubricate moving parts or bearings.

5.5 GROUNDING INSTRUCTIONS

In the event of a malfunction or breakdown, grounding provides a path of least resistance for electric current to reduce the risk of electric shock. This instrument is equipped with an electric cord which is grounded to the chassis housing. The plug must be plugged in to an outlet that is properly installed and grounded in accordance with all local codes and ordinances.

WARNING: DO NOT modify the plug or cord that is provided. Damaged or worn power cords should be repaired or replaced immediately by a qualified electrician.

WARNING: Keep all housings in place and in working order. DO NOT use the motor in a dangerous environment. DO NOT force the unit to do a job it was not designed to do.

WARNING: Reduce the risk of unintentional starting. Make sure that the switch is in the “OFF” position before plugging in the motor.

SECTION 6 — TROUBLESHOOTING

Do not attempt to service the Omni Macro ES in a manner other than those discussed in this manual. For any issue that is unsuccessfully corrected using this guide, please contact your authorized dealer or call Omni International at 1-800-776-4431.

PROBLEM	CORRECTIVE ACTION
The Omni MES is plugged in and turned on but is not functioning.	-Check power cord connectors -Check wall socket for power to the outlet
Motor is turned ON and makes a makes a “buzzing” sound, but is not working.	-Brushes may need to be replaced. Contact Omni International at 1-800-776-4431.
Motor unit operating speed declines, stalls intermittently, or stops completely	-Brushes may need to be replaced. Contact Omni International at 1-800-776-4431.
Teflon bearing wears quickly	-Fluid level may be too low in the tube. -Immerse the probe deeper into the fluid.
Excessive splashing in sample tube	-Fluid level too low for tube size

SECTION 7 — EXPLOSION DRAWINGS AND PART LISTS

7.1 OMNI MACRO ES 11V/220V

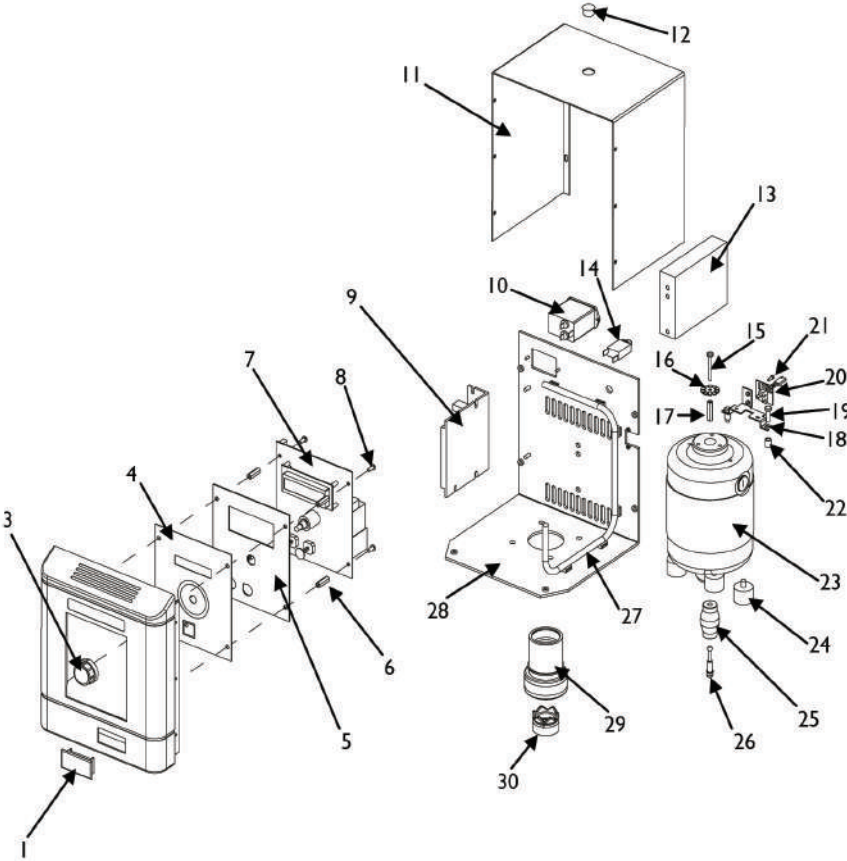

SECTION 7 — EXPLOSION DRAWINGS AND PART LISTS

#	Part Number	Description
1	00-624	Run/Off/Repeat Cover
3	61681	Control Knob
4	Overlay 3	Faceplate Sticker
5	721	Overlay Support
6	00-722	1/4x13/16x8-32 Aluminum Standoff
7	LT300	Control Board
8	60081	8-32x3/8" Screw
9	50175-1	115/220V Speed Control
10	00-101	IEC Filter Switch Combo
11	1822	Cover Panel
12	17577-1	Hole Plug .625" Dia. Blk.
13	1818	Motor Support Bar
14	66758-2	15 Amp Circuit Breaker (115V)
	66760	8 Amp Circuit Breaker (220V)
15	LT800	8-32x1.375 S.S. Pan HP Phillips
16	LT133	Tachometer Wheel
17	LT118	8-32x1" Threaded Standoff
18	LT600	Tachometer Sensor Bracket
19	LT802	10-32x5/8 S.S. Machine Screw
20	LT123	Speed Sensor Arm
21	00-822	4-40x.250" B.H. S.S.
22	LT121	3/9" Spacer
23	615722	115V Macro Motor
	61507-1	220V Macro Motor
24	739	Shock Mount
25	60028	Flew Rubber Coupling
26	17005	Floating Drive Shaft
27	LT900	Wire Harness
28	1824	L-Plate
29	17210	Quick Connect Coupling Assembly
30	17204	Quick Connect Adapter

SECTION 8 — SERVICE

8.1 ASSISTANCE

Should this product ever require service, please contact Omni International at 1-800-776-4431.

8.2 DECONTAMINATION

Should an instrument or component that has been used with radioactive or pathogenic material require factory or field service, comply with the following procedure to ensure the safety of service personnel:

- Clean the parts to be serviced of all encrusted material and decontaminate them. There must be no radioactivity detectable by survey equipment.
- Obtain a Decontamination Certificate from Omni International. Complete the certificate and attach to the instrument or parts being returned.

If no Decontamination Certificate is attached, and a potential radioactive or biological hazard is detected or suspected by Omni International, the equipment will not be serviced until proper decontamination and certification is complete. The sender will be contacted for instructions as to the disposition of the equipment. Disposition costs will be borne by the sender.

WARNING: It is a violation of federal law to transport biologically hazardous or radioactive materials without proper packaging, labeling, and appropriate warnings.

OMNI MES

Macro ES Homogenizer



OMNI
INTERNATIONAL

The Homogenizer Company™

Omni International, Inc.
935C Cobb Place Blvd.
Kennesaw, GA 30144
800.776.4431 • 770.421.0058



www.omni-inc.com