



18,000 BTU/H SLIM DUCTED HEAT PUMP SYSTEM

SUBMITTAL COVER SHEET

PROJECT NAME _____

LOCATION _____



ARCHITECT _____

ENGINEER _____

CONTRACTOR _____

REFERENCE _____

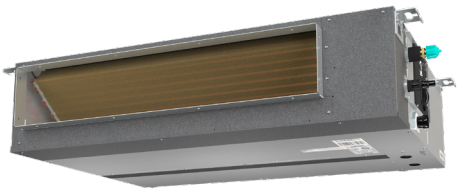
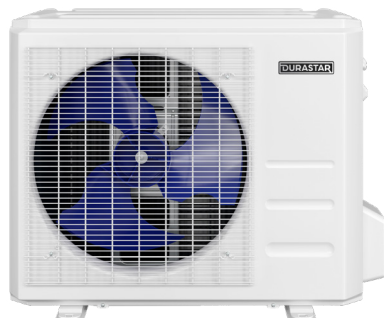
SUBMITTED BY _____ DATE _____

Indoor Unit (IDU): DRAD18F1A	Outdoor Unit (ODU): DRA1U18S1A	Wired Thermostat
		

CAPACITIES		
Cooling Capacity (BTU/hr)	Rated ¹	18000
	Minimum	6400
	Maximum	18800
Heating Capacity (BTU/hr)	Rated ²	18000
	Minimum	6000
	Maximum	18900

EFFICIENCY DATA	
SEER	19.0
EER	12.5
HSPF	10.5

OUTDOOR TEMPERATURE OPERATION	
Cooling	-13 °F - 122 °F (-25 °C - 50 °C)
Heating	-13 °F - 86 °F (-25 °C - 30 °C)

ELECTRICAL DATA	
Voltage/Phase/Frequency	208-230V, 1 Phase, 60 Hz
Voltage Range	187-253V
Recommended Breaker (Amps)	20
Minimum Circuit Ampacity (Amps)	15
Minimum Wire Size	16 AWG
Rated Current - Cooling (Amps) ¹	6.6
Rated Current - Heating (Amps) ²	7.7

PRODUCT FEATURES

- Wired Thermostat Included
- Variable Speed Inverter Compressor
- Auto Restart
- Auto Changeover
- 24-hour Timer

¹Measured at 95 °F.
²Measured at 47 °F.





18,000 BTU/H SLIM DUCTED HEAT PUMP SYSTEM

SPECIFICATIONS

SYSTEM DATA	
Refrigerant Type	R-410A
Refrigerant Charge (oz.)	68.8
Oil Type	Ester Oil VG74
Oil Charge (oz.)	15.2 (450 ml)
Design Pressure (PSIG)	550/340

LINE SET REQUIREMENTS	
Connection Type	Flare
Liquid	Ø1/4" (Ø6.35mm)
Gas	Ø1/2" (Ø12.7mm)
Pre-Charge Length	25'
Minimum Length	10'
Maximum Length	98'
Maximum Height Differential	66'
Additional Refrigerant (oz./ft)	0.16

FAN DATA		
Static Pressure (in wg)	0-0.40	
Indoor Unit Air Flow (CFM)	Low	371
	Medium	450
	High	530
Moisture Removal (Pints/hr)	2.42	
Drain Port O.D. / Drain Hose I.D.	Ø1" (Ø25mm)	

SOUND PRESSURE (dB(A))		
Indoor Unit	Low	35
	Medium	37
	High	39
Outdoor Unit	60	

INDOOR UNIT DIMENSIONS		
Unit Dimensions	Width	34 5/8"
	Depth	26 9/16"
	Height	8 1/4"
Carton Dimensions	Width	42 1/8"
	Depth	28 9/16"
	Height	10 5/8"
Net Weight	55.3 lbs.	
Gross Weight	67.0 lbs.	

OUTDOOR UNIT DIMENSIONS		
Unit Dimensions	Width	33 1/4"
	Depth	14 5/16"
	Height	27 5/8"
Carton Dimensions	Width	38"
	Depth	15 9/16"
	Height	30 1/2"
Net Weight	105.2 lbs.	
Gross Weight	112.4 lbs.	



18,000 BTU/H SLIM DUCTED HEAT PUMP SYSTEM

IDU DIMENSIONS - DRAD18F1A

Unit and air outlet dimensions

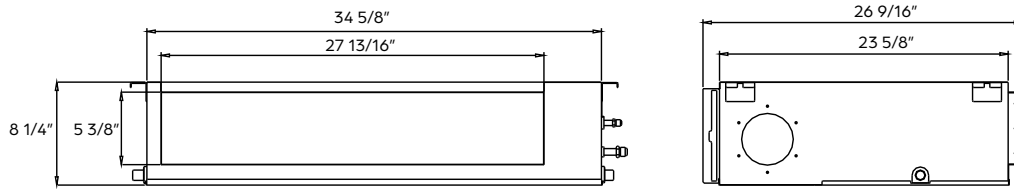

Air inlet dimensions

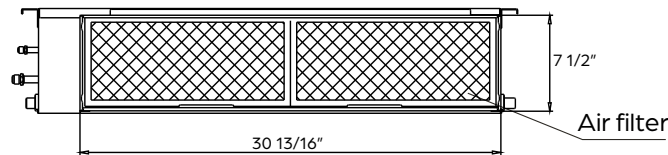

Mounting dimensions for ceiling bolts

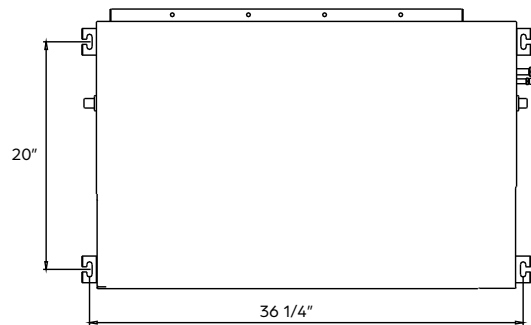

Installation clearances

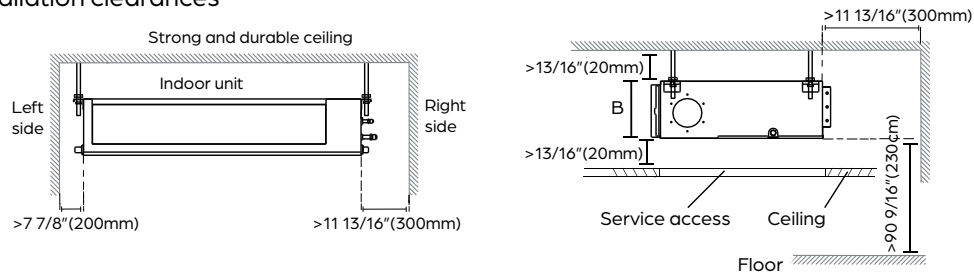

Maintenance access panel

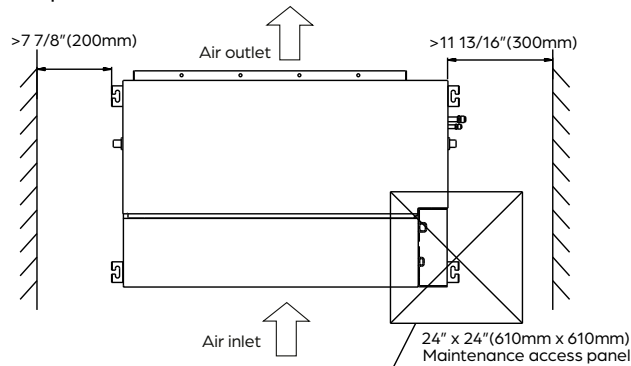

NOTE

For horizontal installation only.



18,000 BTU/H SLIM DUCTED HEAT PUMP SYSTEM

ODU DIMENSIONS - DRA1U18S1A

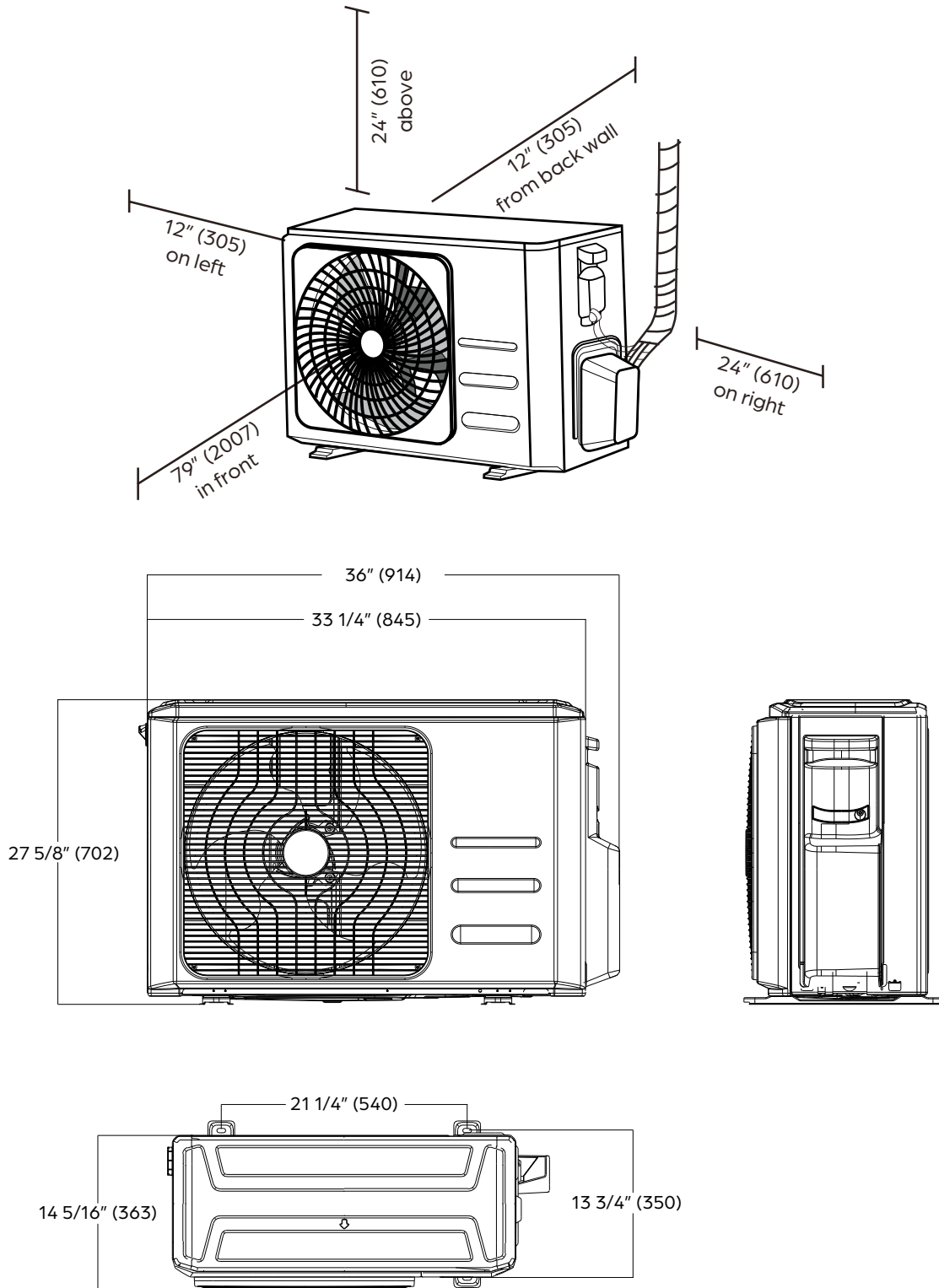

NOTE

Illustrations in this document are for explanatory purposes. The actual shape of your mini-split equipment may vary slightly.