



12,000 BTU/H FLOOR MOUNTED HEAT PUMP SYSTEM

SUBMITTAL COVER SHEET

PROJECT NAME _____

LOCATION _____



ARCHITECT _____

ENGINEER _____

CONTRACTOR _____

REFERENCE _____

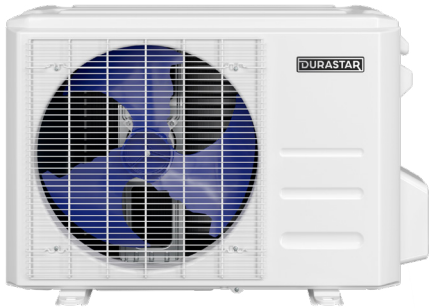
SUBMITTED BY _____ DATE _____

Indoor Unit (IDU): DRAS12F1A	Outdoor Unit (ODU): DRA1U12S1A	Wireless Remote Control
		

CAPACITIES		
Cooling Capacity (BTU/hr)	Rated ¹	12000
	Minimum	4200
	Maximum	13100
Heating Capacity (BTU/hr)	Rated ²	12000
	Minimum	4800
	Maximum	13600

EFFICIENCY DATA	
SEER	20.5
EER	13.0
HSPF	10.0

PRODUCT FEATURES

- Wireless Remote Control with "Follow Me" Technology
- Variable Speed Inverter Compressor
- Auto Restart
- Auto Changeover
- 24-hour Timer
- Self Clean Function

OUTDOOR TEMPERATURE OPERATION	
Cooling	-13 °F - 122 °F (-25 °C - 50 °C)
Heating	-13 °F - 86 °F (-25 °C - 30 °C)

ELECTRICAL DATA	
Voltage/Phase/Frequency	208-230V, 1 Phase, 60 Hz
Voltage Range	187-253V
Recommended Breaker (Amps)	15
Minimum Circuit Ampacity (Amps)	12
Minimum Wire Size	16 AWG
Rated Current - Cooling (Amps) ¹	4.22
Rated Current - Heating (Amps) ²	4.39

¹ Measured at 95 °F.
² Measured at 47 °F.





12,000 BTU/H FLOOR MOUNTED HEAT PUMP SYSTEM

SPECIFICATIONS

SYSTEM DATA	
Refrigerant Type	R-410A
Refrigerant Charge (oz.)	40.6
Oil Type	Ester Oil VG74
Oil Charge (oz.)	12.5 (370 ml)
Design Pressure (PSIG)	550/340

LINE SET REQUIREMENTS	
Connection Type	Flare
Liquid	Ø1/4" (Ø6.35mm)
Gas	Ø1/2" (Ø12.7mm)
Pre-Charge Length	25'
Minimum Length	10'
Maximum Length	82'
Maximum Height Differential	33'
Additional Refrigerant (oz./ft)	0.16

FAN DATA		
Indoor Unit Air Flow (CFM)	Low	201
	Medium	276
	High	321
Moisture Removal (Pints/hr)	2.65	
Drain Port O.D. / Drain Hose I.D.	Ø5/8" (Ø16mm)	

SOUND PRESSURE (dB(A))		
Indoor Unit	Low	37
	Medium	46
	High	48
Outdoor Unit	55	

INDOOR UNIT DIMENSIONS		
Unit Dimensions	Width	27 9/16"
	Depth	8 1/4"
	Height	23 5/8"
Carton Dimensions	Width	30 11/16"
	Depth	11 13/16"
	Height	27"
Net Weight	32.6 lbs.	
Gross Weight	41.0 lbs.	

OUTDOOR UNIT DIMENSIONS		
Unit Dimensions	Width	31 1/2"
	Depth	13 1/8"
	Height	21 13/16"
Carton Dimensions	Width	36"
	Depth	15 3/8"
	Height	24 1/2"
Net Weight	80.5 lbs.	
Gross Weight	86.2 lbs.	



12,000 BTU/H FLOOR MOUNTED HEAT PUMP SYSTEM

IDU DIMENSIONS - DRAS12F1A

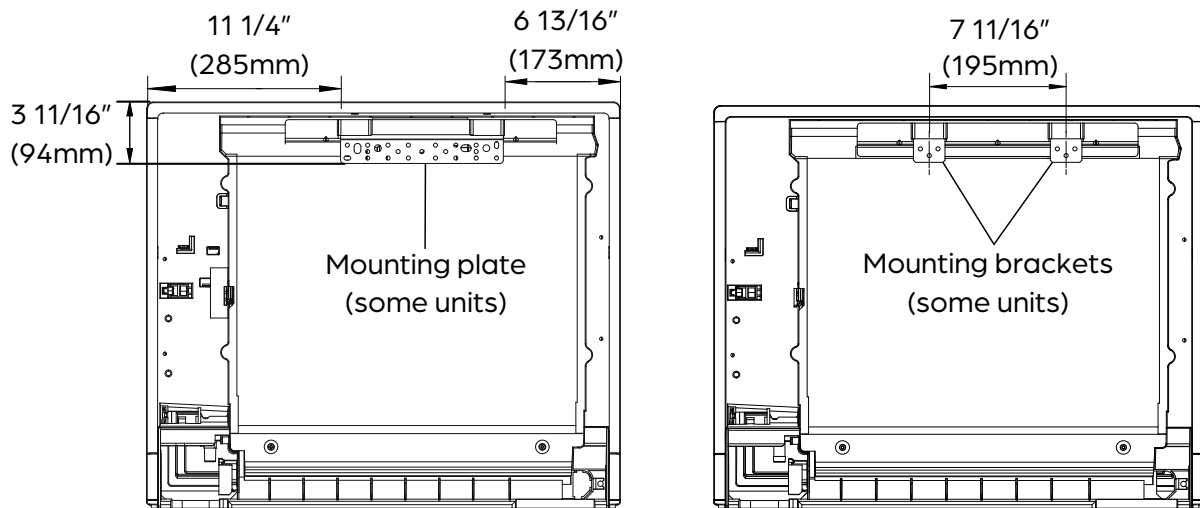
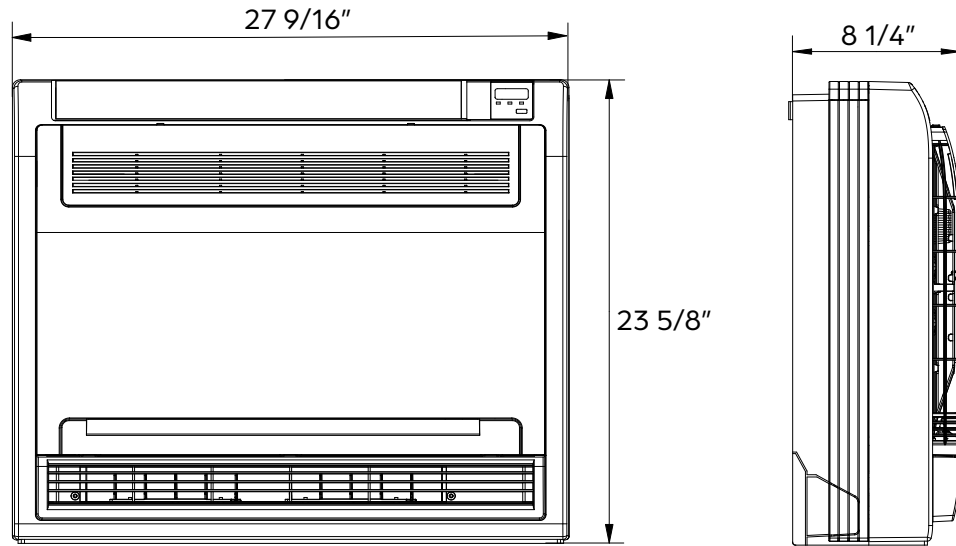



12,000 BTU/H FLOOR MOUNTED HEAT PUMP SYSTEM

ODU DIMENSIONS - DRA1U12S1A

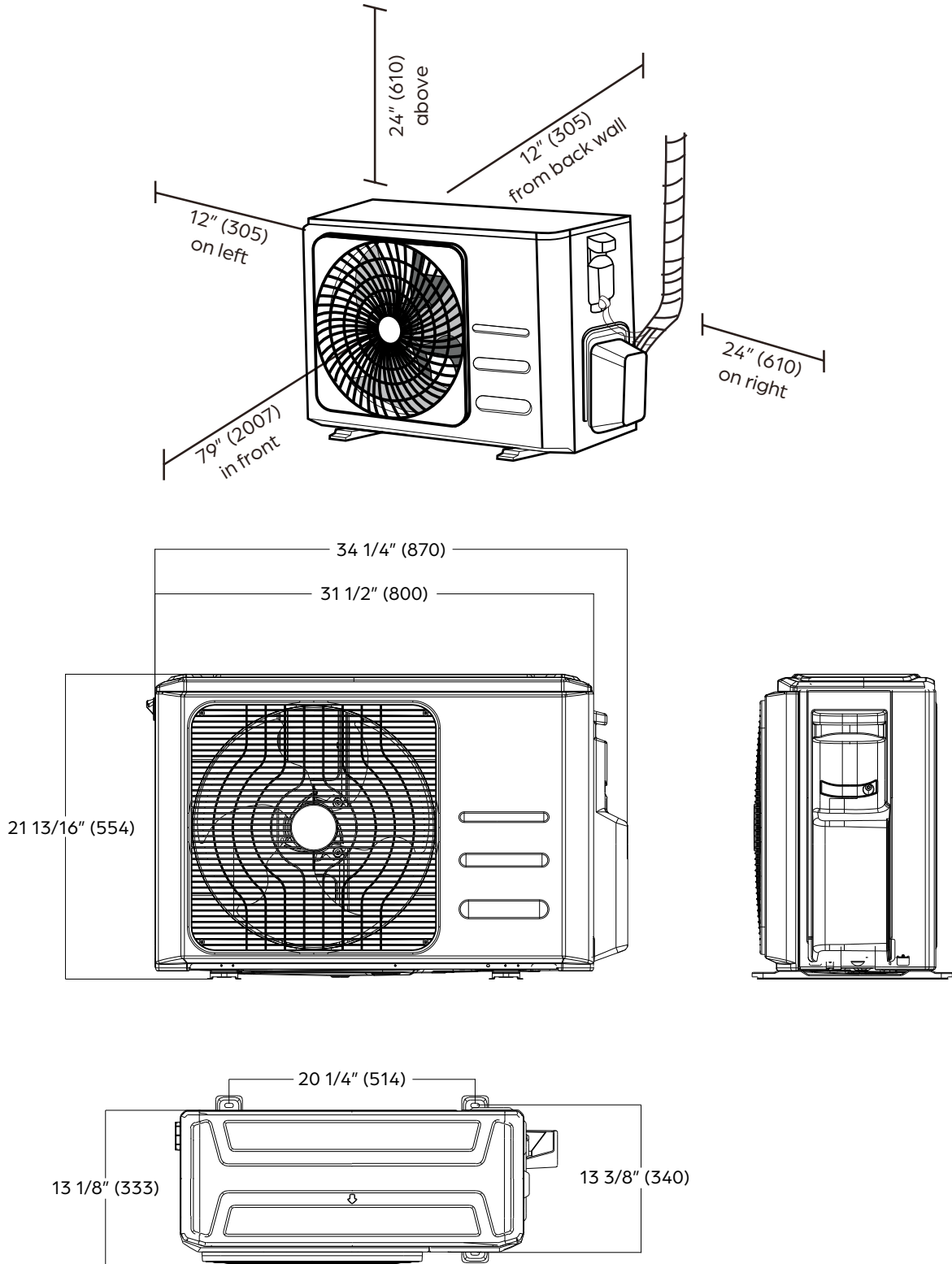

NOTE

Illustrations in this document are for explanatory purposes. The actual shape of your mini-split equipment may vary slightly.