



9,000 BTU/H CEILING CASSETTE HEAT PUMP SYSTEM

SUBMITTAL COVER SHEET

PROJECT NAME _____

LOCATION _____





ARCHITECT _____

ENGINEER _____

CONTRACTOR _____

REFERENCE _____

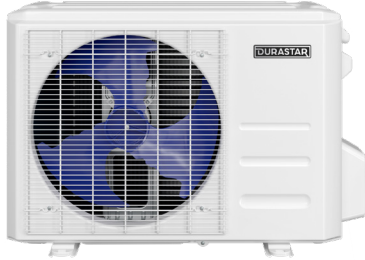
SUBMITTED BY _____ DATE _____

Indoor Unit (IDU): DRAC09F1A	Panel: DRACPANA1A*	Outdoor Unit (ODU): DRA1U09S1A	Wireless Remote Control
			

CAPACITIES		
Cooling Capacity (BTU/hr)	Rated ¹	9000
	Minimum	3250
	Maximum	9500
Heating Capacity (BTU/hr)	Rated ²	10000
	Minimum	3050
	Maximum	10500

EFFICIENCY DATA	
SEER	20.0
EER	13.0
HSPF	10.5

PRODUCT FEATURES

- Wireless Remote Control with "Follow Me" Technology
- Variable Speed Inverter Compressor
- Auto Restart
- Auto Changeover
- 24-hour Timer
- Self Clean Function

*Panel sold separately

OUTDOOR TEMPERATURE OPERATION	
Cooling	-13 °F - 122 °F (-25 °C - 50 °C)
Heating	-13 °F - 86 °F (-25 °C - 30 °C)

ELECTRICAL DATA	
Voltage/Phase/Frequency	208-230V, 1 Phase, 60 Hz
Voltage Range	187-253V
Recommended Breaker (Amps)	15
Minimum Circuit Ampacity (Amps)	10
Minimum Wire Size	16 AWG
Rated Current - Cooling (Amps) ¹	3.17
Rated Current - Heating (Amps) ²	4.0

¹ Measured at 95 °F.
² Measured at 47 °F.





9,000 BTU/H CEILING CASSETTE HEAT PUMP SYSTEM

SPECIFICATIONS

SYSTEM DATA	
Refrigerant Type	R-410A
Refrigerant Charge (oz.)	38.8
Oil Type	Ester Oil VG74
Oil Charge (oz.)	12.5 (370 ml)
Design Pressure (PSIG)	550/340

LINE SET REQUIREMENTS	
Connection Type	Flare
Liquid	Ø1/4" (Ø6.35mm)
Gas	Ø3/8" (Ø9.52mm)
Pre-Charge Length	25'
Minimum Length	10'
Maximum Length	82'
Maximum Height Differential	33'
Additional Refrigerant (oz./ft)	0.16

FAN DATA		
Indoor Unit Air Flow (CFM)	Low	257
	Medium	301
	High	374
Moisture Removal (Pints/hr)	1.71	
Drain Port O.D. / Drain Hose I.D.	Ø1" (Ø25mm)	

SOUND PRESSURE (dB(A))		
Indoor Unit	Low	33
	Medium	37
	High	41
Outdoor Unit	55	

INDOOR UNIT DIMENSIONS		
Unit Dimensions	Width	22 7/16"
	Depth	22 7/16"
	Height	10 1/4"
Carton Dimensions	Width	26 1/2"
	Depth	26 1/2"
	Height	13 1/4"
Net Weight	32.0 lbs.	
Gross Weight	38.1 lbs.	

OUTDOOR UNIT DIMENSIONS		
Unit Dimensions	Width	30 5/16"
	Depth	11 13/16"
	Height	21 7/8"
Carton Dimensions	Width	35 7/16"
	Depth	13 9/16"
	Height	23"
Net Weight	67.2 lbs.	
Gross Weight	71.7 lbs.	



9,000 BTU/H CEILING CASSETTE HEAT PUMP SYSTEM

IDU DIMENSIONS - DRAC09F1A

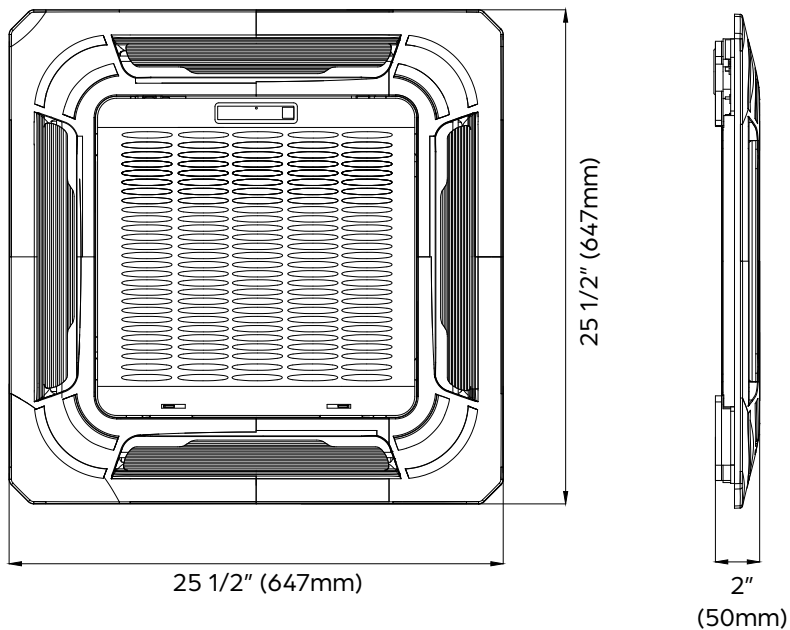
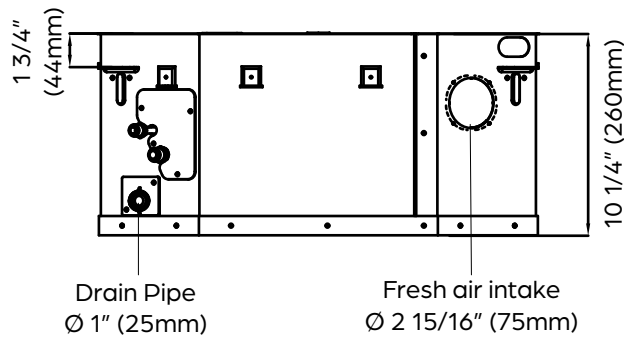
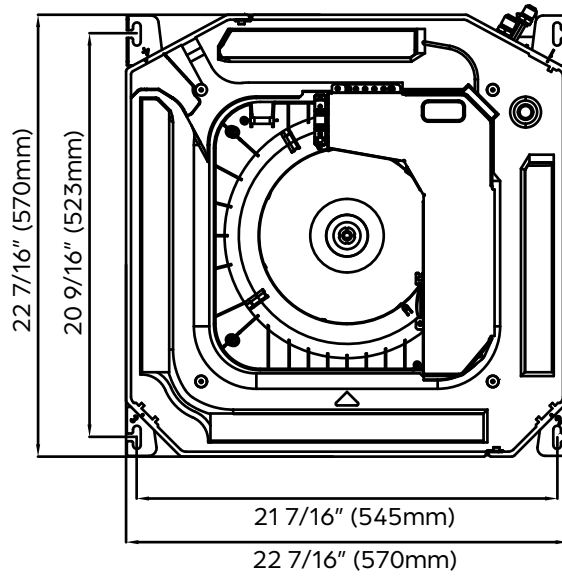



9,000 BTU/H CEILING CASSETTE HEAT PUMP SYSTEM

ODU DIMENSIONS - DRA1U09S1A

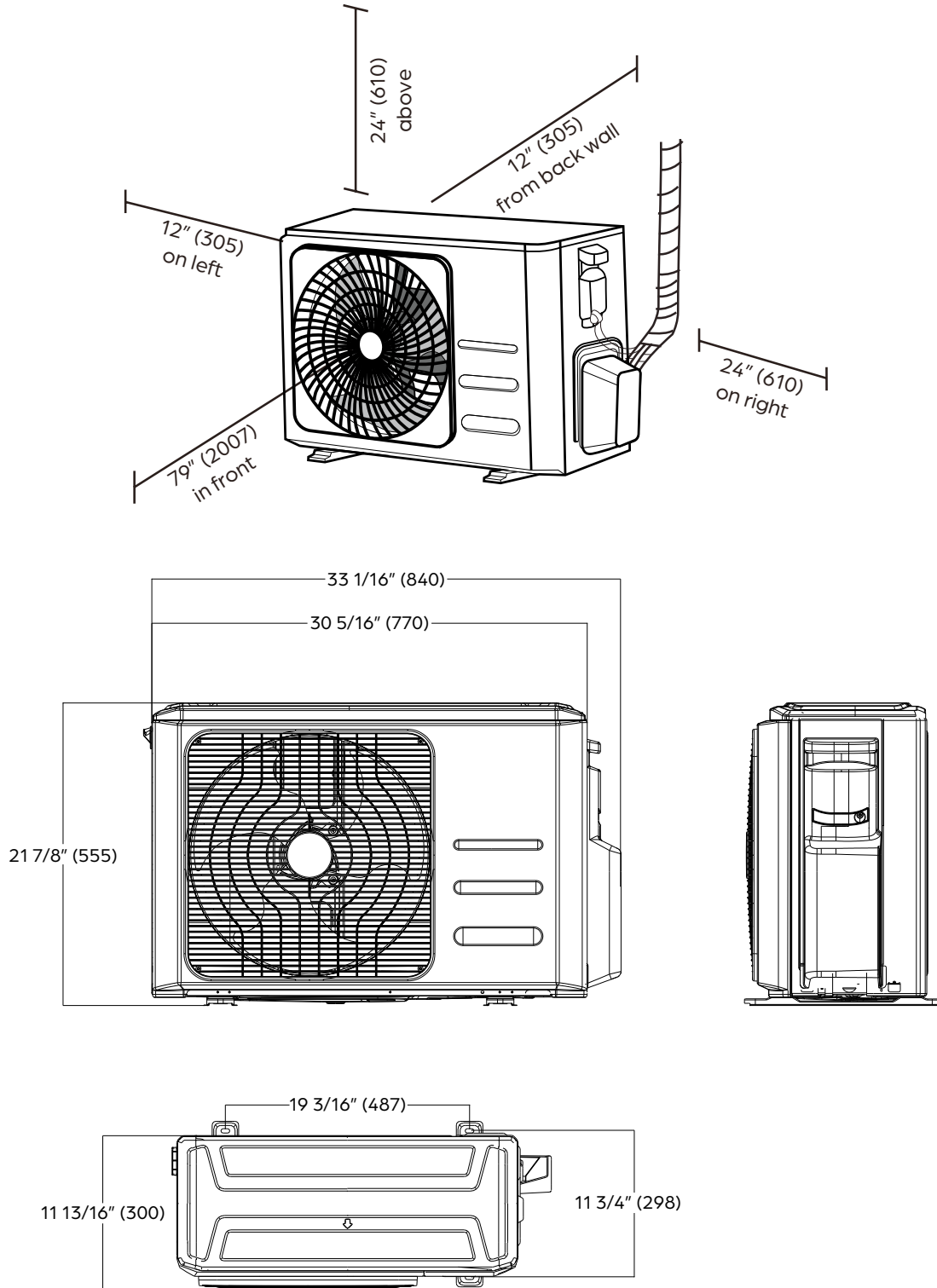

NOTE

Illustrations in this document are for explanatory purposes. The actual shape of your mini-split equipment may vary slightly.