



24,000 BTU/H WALL MOUNTED HEAT PUMP SYSTEM

SUBMITTAL COVER SHEET

PROJECT NAME _____

LOCATION _____



ARCHITECT _____

ENGINEER _____

CONTRACTOR _____

REFERENCE _____

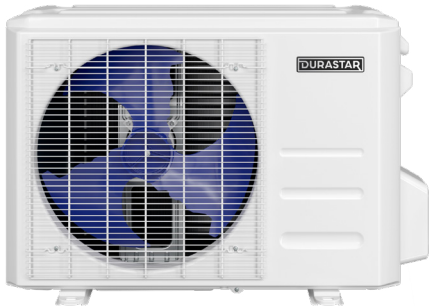
SUBMITTED BY _____ DATE _____

Indoor Unit (IDU): DRAW24F1A	Outdoor Unit (ODU): DRA1U24S1A	Wireless Remote Control
		

CAPACITIES		
Cooling Capacity (BTU/hr)	Rated ¹	24000
	Minimum	6850
	Maximum	24500
Heating Capacity (BTU/hr)	Rated ²	25000
	Minimum	7200
	Maximum	27500

EFFICIENCY DATA	
SEER	20.5
EER	12.5
HSPF	10.0

OUTDOOR TEMPERATURE OPERATION	
Cooling	-13 °F - 122 °F (-25 °C - 50 °C)
Heating	-13 °F - 86 °F (-25 °C - 30 °C)

ELECTRICAL DATA	
Voltage/Phase/Frequency	208-230V, 1 Phase, 60 Hz
Voltage Range	187-253V
Recommended Breaker (Amps)	25
Minimum Circuit Ampacity (Amps)	18
Minimum Wire Size	16 AWG
Rated Current - Cooling (Amps) ¹	8.4
Rated Current - Heating (Amps) ²	10.1

PRODUCT FEATURES

- Wireless Remote Control with "Follow Me" Technology
- Variable Speed Inverter Compressor
- Auto Restart
- Auto Changeover
- 24-hour Timer
- Self Clean Function

¹Measured at 95 °F.

²Measured at 47 °F.





24,000 BTU/H WALL MOUNTED HEAT PUMP SYSTEM

SPECIFICATIONS

SYSTEM DATA	
Refrigerant Type	R-410A
Refrigerant Charge (oz.)	82.9
Oil Type	Ester Oil VG74
Oil Charge (oz.)	22.7 (670 ml)
Design Pressure (PSIG)	550/340

LINE SET REQUIREMENTS	
Connection Type	Flare
Liquid	Ø3/8" (Ø9.52mm)
Gas	Ø5/8" (Ø16mm)
Pre-Charge Length	25'
Minimum Length	10'
Maximum Length	164'
Maximum Height Differential	82'
Additional Refrigerant (oz./ft)	0.32

FAN DATA		
Indoor Unit Air Flow (CFM)	Low	324
	Medium	471
	High	618
Moisture Removal (Pints/hr)	5.37	
Drain Port O.D. / Drain Hose I.D.	Ø5/8" (Ø16mm)	

SOUND PRESSURE (dB(A))		
Indoor Unit	Low	33
	Medium	42
	High	47.5
Outdoor Unit	61	

INDOOR UNIT DIMENSIONS		
Unit Dimensions	Width	42 1/2"
	Depth	8 7/8"
	Height	13 3/16"
Carton Dimensions	Width	45 1/2"
	Depth	12 5/8"
	Height	16 5/16"
Net Weight	31.0 lbs.	
Gross Weight	38.0 lbs.	

OUTDOOR UNIT DIMENSIONS		
Unit Dimensions	Width	37 1/4"
	Depth	16 1/8"
	Height	31 7/8"
Carton Dimensions	Width	42 15/16"
	Depth	19 11/16"
	Height	34 13/16"
Net Weight	141.1 lbs.	
Gross Weight	152.1 lbs.	



24,000 BTU/H WALL MOUNTED HEAT PUMP SYSTEM

IDU DIMENSIONS - DRAW24F1A

Unit Dimensions

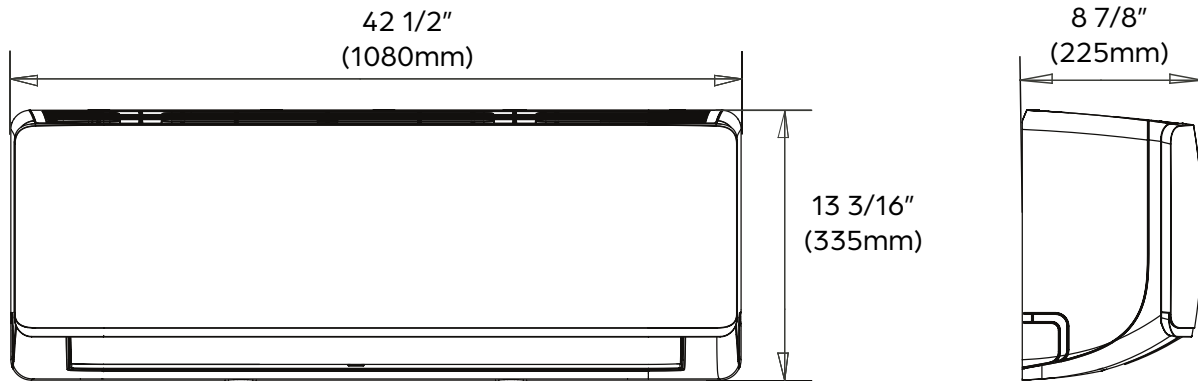

Mounting Plate Dimensions

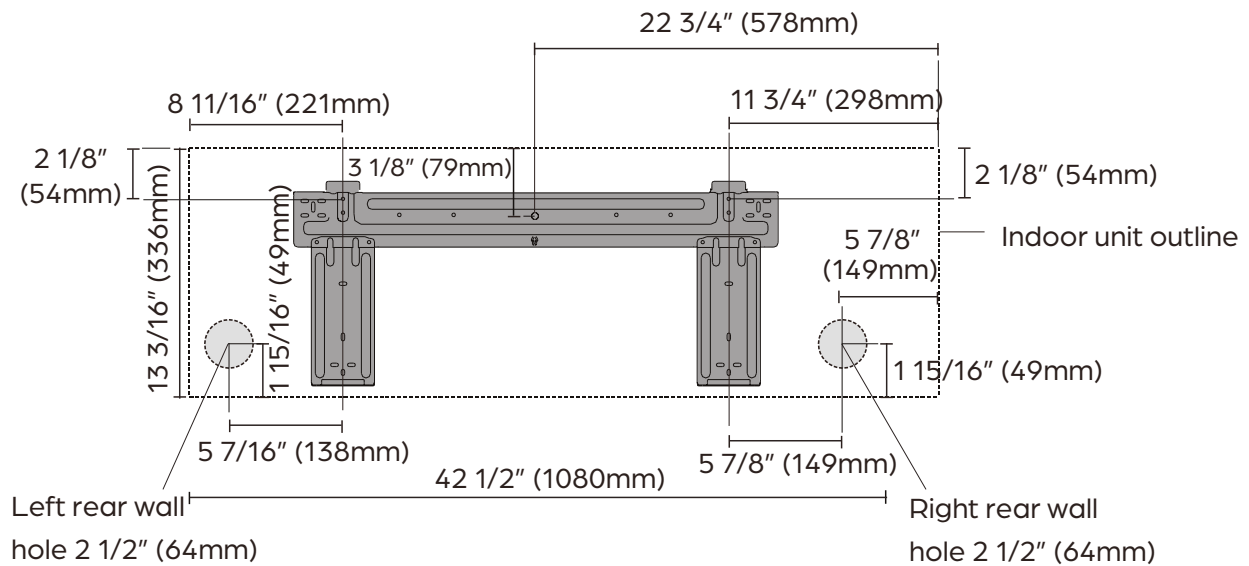

Clearance Distances

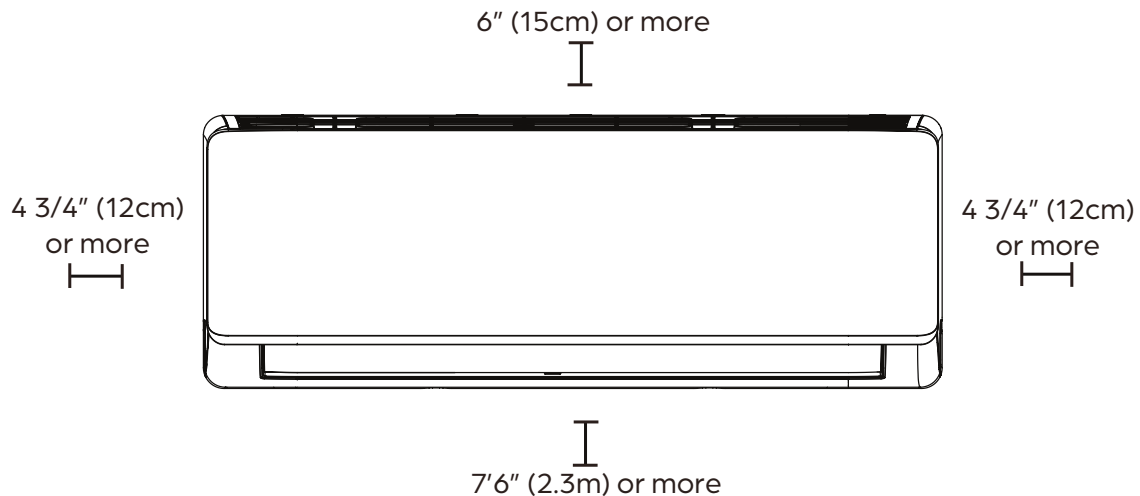



24,000 BTU/H WALL MOUNTED HEAT PUMP SYSTEM

ODU DIMENSIONS - DRA1U24S1A

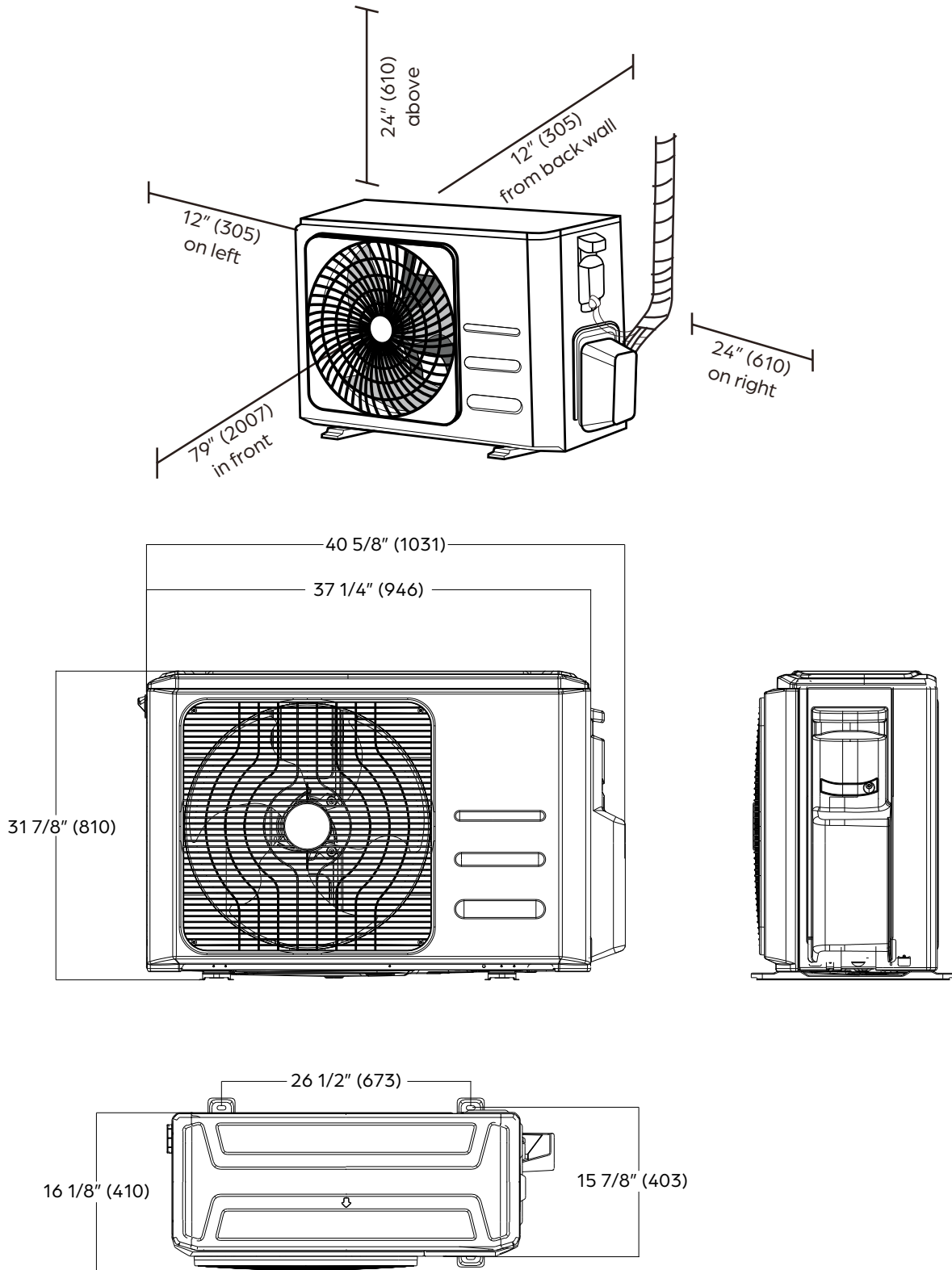

NOTE

Illustrations in this document are for explanatory purposes. The actual shape of your mini-split equipment may vary slightly.

Specifications are subject to change without notice.

© 2021 Ferguson Enterprises LLC

www.durastar.com