



# 12,000 BTU/H SLIM DUCTED HEAT PUMP SYSTEM

SUBMITTAL COVER SHEET

PROJECT NAME \_\_\_\_\_

LOCATION \_\_\_\_\_



ARCHITECT \_\_\_\_\_

ENGINEER \_\_\_\_\_

CONTRACTOR \_\_\_\_\_

REFERENCE \_\_\_\_\_

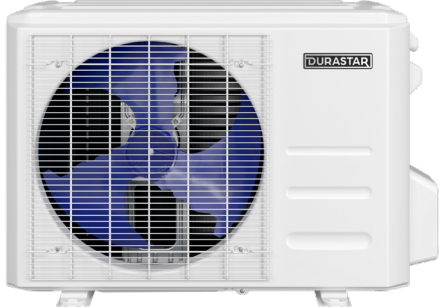
SUBMITTED BY \_\_\_\_\_ DATE \_\_\_\_\_

Indoor Unit (IDU): DRAD12F1A	Outdoor Unit (ODU): DRA1U12S1A	Wired Thermostat
		

CAPACITIES		
Cooling Capacity (BTU/hr)	Rated <sup>1</sup>	12000
	Minimum	4100
	Maximum	12100
Heating Capacity (BTU/hr)	Rated <sup>2</sup>	12000
	Minimum	3600
	Maximum	12100

EFFICIENCY DATA	
SEER	21.5
EER	12.5
HSPF	11.5

### PRODUCT FEATURES

- Wired Thermostat Included
- Variable Speed Inverter Compressor
- Auto Restart
- Auto Changeover
- 24-hour Timer

OUTDOOR TEMPERATURE OPERATION	
Cooling	-13 °F - 122 °F (-25 °C - 50 °C)
Heating	-13 °F - 86 °F (-25 °C - 30 °C)

ELECTRICAL DATA	
Voltage/Phase/Frequency	208-230V, 1 Phase, 60 Hz
Voltage Range	187-253V
Recommended Breaker (Amps)	15
Minimum Circuit Ampacity (Amps)	12
Minimum Wire Size	16 AWG
Rated Current - Cooling (Amps) <sup>1</sup>	4.4
Rated Current - Heating (Amps) <sup>2</sup>	5.05

<sup>1</sup> Measured at 95 °F.  
<sup>2</sup> Measured at 47 °F.





# 12,000 BTU/H SLIM DUCTED HEAT PUMP SYSTEM

SPECIFICATIONS

SYSTEM DATA	
Refrigerant Type	R-410A
Refrigerant Charge (oz.)	40.6
Oil Type	Ester Oil VG74
Oil Charge (oz.)	12.5 (370 ml)
Design Pressure (PSIG)	550/340

LINE SET REQUIREMENTS	
Connection Type	Flare
Liquid	Ø1/4" (Ø6.35mm)
Gas	Ø1/2" (Ø12.7mm)
Pre-Charge Length	25'
Minimum Length	10'
Maximum Length	82'
Maximum Height Differential	33'
Additional Refrigerant	0.16 oz./ft.

FAN DATA		
Static Pressure (in wg)	0-0.16	
Indoor Unit Air Flow (CFM)	Low	177
	Medium	283
	High	353
Moisture Removal (Pints/hr)	2.3	
Drain Port O.D. / Drain Hose I.D.	Ø1" (Ø25mm)	

SOUND PRESSURE (dB(A))		
Indoor Unit	Low	33.5
	Medium	36
	High	38
Outdoor Unit	55	

INDOOR UNIT DIMENSIONS		
Unit Dimensions	Width	27 9/16"
	Depth	19 15/16"
	Height	7 7/8"
Carton Dimensions	Width	33 7/8"
	Depth	21 1/4"
	Height	11"
Net Weight	39.2 lbs.	
Gross Weight	51.0 lbs.	

OUTDOOR UNIT DIMENSIONS		
Unit Dimensions	Width	31 1/2"
	Depth	13 1/8"
	Height	21 13/16"
Carton Dimensions	Width	36"
	Depth	15 3/8"
	Height	24 1/2"
Net Weight	80.5 lbs.	
Gross Weight	86.2 lbs.	



# 12,000 BTU/H SLIM DUCTED HEAT PUMP SYSTEM

IDU DIMENSIONS - DRAD12F1A

## Unit and air outlet dimensions

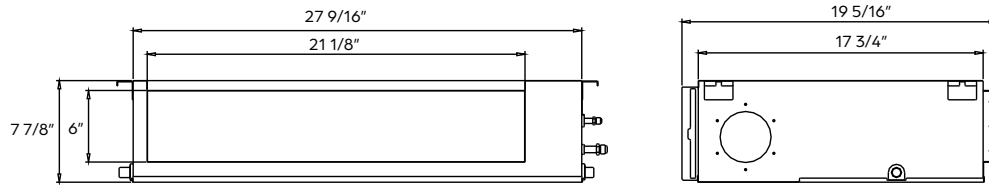

## Air inlet dimensions

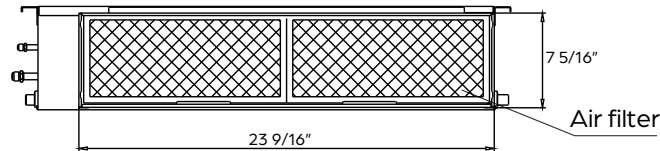

## Mounting dimensions for ceiling bolts

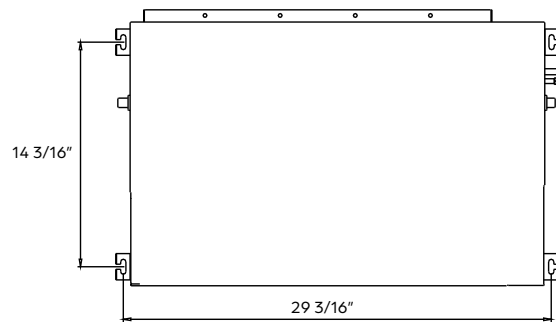

## Installation clearances

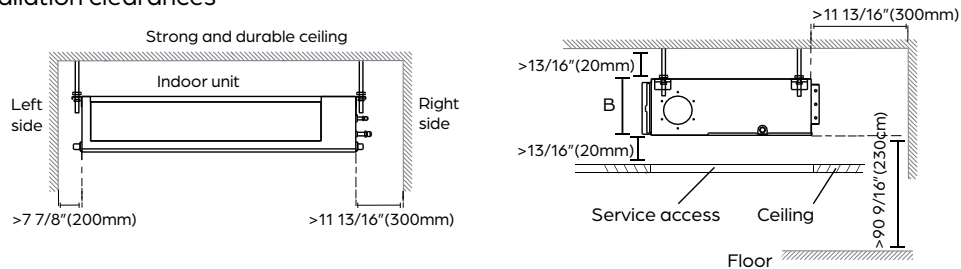

## Maintenance access panel

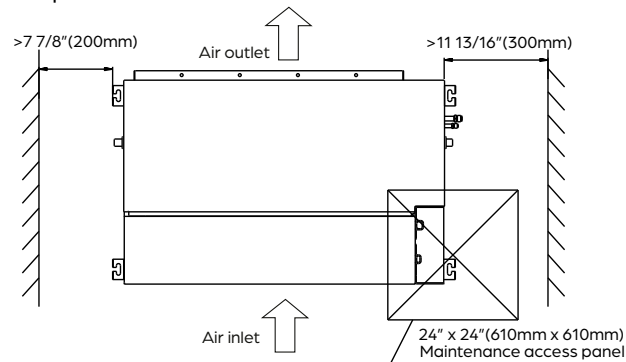

### NOTE

For horizontal installation only.



# 12,000 BTU/H SLIM DUCTED HEAT PUMP SYSTEM

ODU DIMENSIONS - DRA1U12S1A

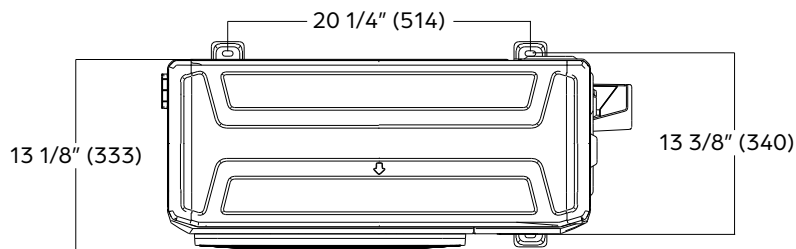
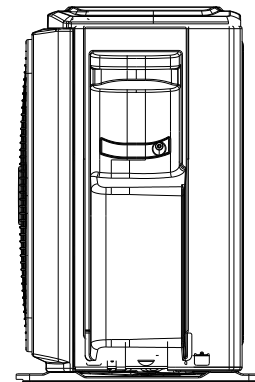
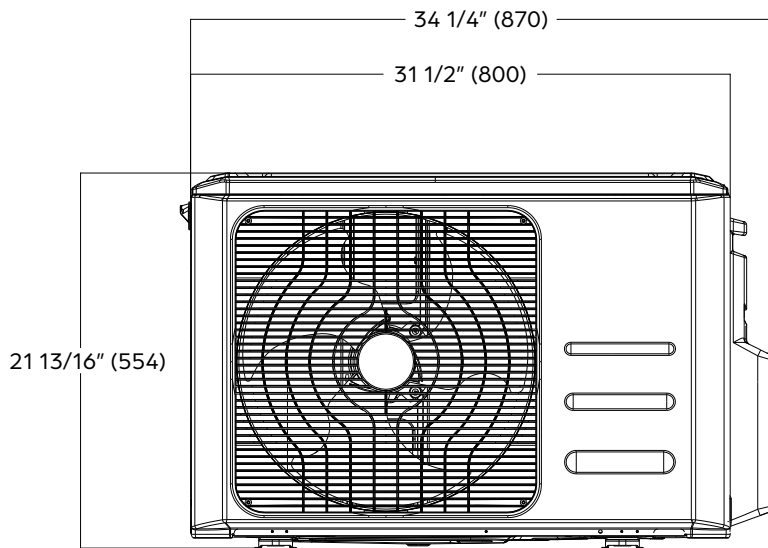
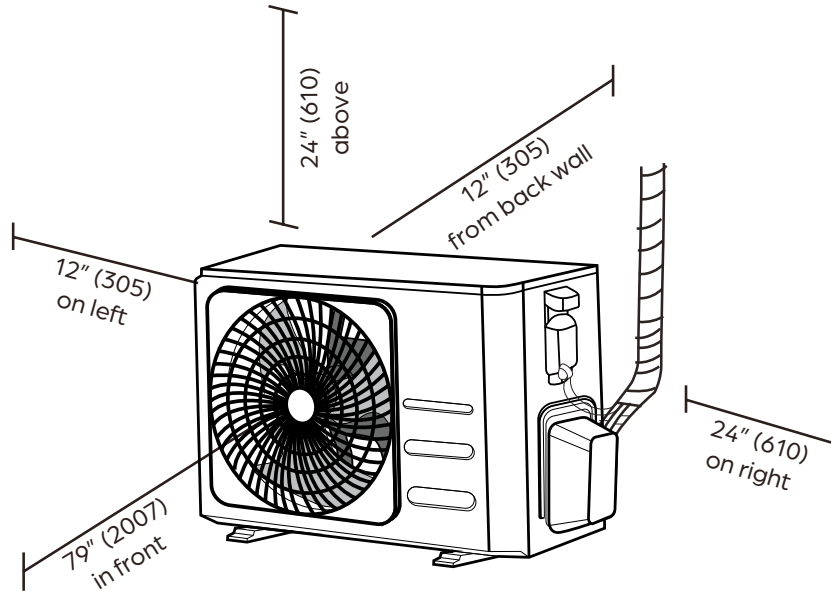

## NOTE

Illustrations in this document are for explanatory purposes. The actual shape of your mini-split equipment may vary slightly.