



INSTALLATION MANUAL

THIRD-PARTY THERMOSTAT INTERFACE

FOR DURASTAR SPLIT-STYLE INDOOR UNITS

208/230V~60HZ, 1PH

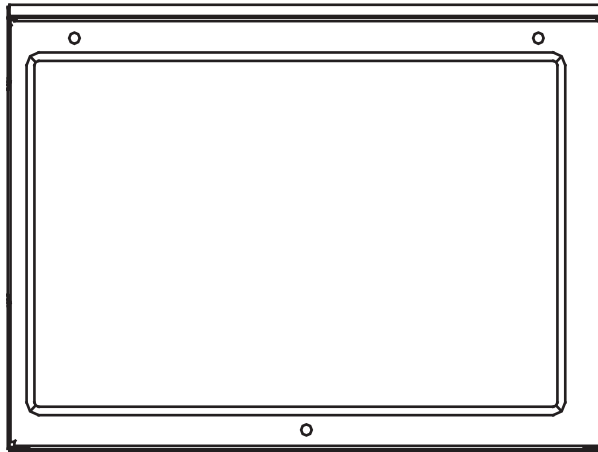

Model Number: _____

Serial Number: _____

Purchase Date: _____

Installing Contractor Company Name: _____

TIP

Capture relevant information about your equipment before it is installed and write it above for future reference.



Table of Contents

Introduction.....	3
Important Safety Precautions.....	3
Electrical Safety.....	3
Installation Safety.....	3
Supported Mini-Split Units.....	4
Supported Thermostats.....	4
Parts Identification.....	4
Installation Location.....	5
Unit Installation.....	6
Wiring and Configuring.....	7
Wiring the third-party thermostat interface.....	7
Configuring the DIP Switches.....	8
Error Codes.....	9
Wiring Diagram.....	10
LIMITED WARRANTY - PARTS.....	11

Introduction

To better serve you, please do the following before contacting customer service:

- If you received a damaged product, immediately contact the retailer or dealer that sold you the product.
- Read and follow this owner's manual carefully to help you use and maintain your air conditioner.
- Read the troubleshooting section of this manual as it will help you diagnose and solve common issues.
- Visit us on the web at www.durastar.com to download product guides and up-to-date information.
- If you need warranty service, our friendly customer service representatives are available via email at question@durastar.com or by telephone at 1-888-320-0706.

Important Safety Precautions

Improper handling can cause serious damage or injury. Please read the following safety information in its entirety.



Electrical Safety

- The product must be properly grounded at the time of installation, or electrical shock may occur.
- For all electrical work, follow all local and national wiring standards and regulations. Connect cables tightly, and clamp them securely to prevent external forces from damaging wiring terminals. Improper electrical connections can overheat and cause fire, and may also cause shock.
- All electrical connections must be made according to the Electrical Connection Diagram located on the unit's control box and the panels of the indoor and outdoor units.
- All wiring must be properly arranged to ensure that the control board cover can close properly. If the control board cover is not closed properly, it can lead to corrosion and cause the connection points on the terminal to heat up, catch fire, or cause electrical shock.
- All wires must be properly sized according to the NEC/NFPA 70, CEC and all prevailing codes, ordinances and standards.
- Installation should be performed by a licensed contractor or electrician. Improper installation may result in electric shock or fire.
- Ensure the power to both the indoor and outdoor unit is disconnected before installing this kit.
- Do not install the control box in area subject to excessive moisture, near flammable liquids or gases.



Installation Safety

- Installation must be performed by an authorized dealer or specialist. Improper installation can cause water leakage, electrical shock, or fire. (In North America, installation must be performed in accordance with NEC and CEC requirements by authorized personnel only.)
- Installation must be performed according to the installation instructions. Improper installation can cause water leakage, electrical shock, or fire.
- The unit shall be installed in accordance with national and local wiring regulations. Contact an authorized service technician for repair or maintenance of this unit.
- Only use the included accessories, parts, and specified parts for installation. Using nonstandard parts can cause water leakage, electrical shock, fire, and can cause the unit to fail.
- Do not install the unit in area subject to excessive moisture.
- Do not install the unit near flammable liquids or gases, or fire may result.
- Do not install the unit in a location that may be exposed to combustible gas leaks. If combustible gas accumulates around the unit, it may cause a fire.
- Do not turn on the power until all work has been completed.
- If moving or relocating the unit, consult experienced service technicians for disconnection and reinstallation of the unit.



Supported Mini-Split Units

Outdoor:

- Single Zone - DRA1U09S1A, DRA1U12S1A, DRA1U18S1A, DRA1U24S1A, DRA1U09S1B, DRA1U12S1B, DRA1U18S1B, DRA1U24S1B, DRA1H09S1A, DRA1H12S1A, DRA1H18S1A, DRA1H24S1A
- Multi-Zone - DRA2U18M1A, DRA3U28M1A, DRA4U36M1A, DRA5U48M1A, DRA2U18M1B, DRA3U28M1B, DRA4U36M1B, DRA5U48M1B, DRA5U55M1B, DRA2H18M1A, DRA3H28M1A, DRA4H36M1A, DRA5H48M1A, DRA5H55M1A

Indoor:

- Wall Mounted - DRAW09F1A, DRAW12F1A, DRAW18F1A, DRAW24F1A, DRAW06F1B, DRAW09F1B, DRAW12F1B, DRAW18F1B, DRAW24F1B
- Cassette - DRAC09F1A, DRAC12F1A, DRAC18F1A, DRAC24F1A, DRAC24F1B
- One-Way Cassette - DRAL06F1A, DRAL09F1A, DRAL12F1A, DRAL18F1A
- Slim Ducted - DRAD09F1A, DRAD12F1A, DRAD18F1A, DRAD24F1A
- Floor/Ceiling - DRAF18F1A, DRAF24F1A
- Floor Mounted - DRAS12F1A, DRAS12F1B

Supported Thermostats

Supported third-party thermostats:

This system is designed for operation with standard 24VAC HVAC thermostats. Standard Wifi HVAC thermostats such as NEST, Ecobee, Honeywell, etc. may be used with this interface unit.

Parts Identification

Number	Name	Quantity	Remarks
1	Control Box	1	24V thermostat interface
2	Screws	3	M4*20 for mounting
3	Anchors	3	For mounting M4*20 screws

Optional

4	Magnetic Ring	1	See wiring diagram
5	Sensor	1	Sensor
6	5m Sensor Extension	1	Extension for sensor

Installation Location

Unit Dimensions

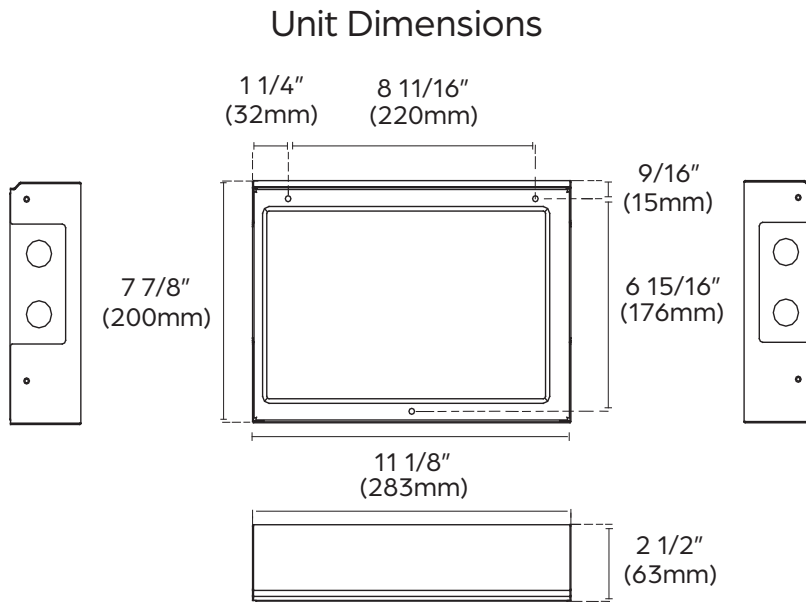

NOTE

- The installation must be performed in accordance with the required local and national standards. The installation may be slightly different in different areas.

Installation Requirements

- The unit should be installed indoors. If installed outdoors, the thermostat **MUST BE** contained within an approved waterproof enclosure.
- Install the unit with 6" of clearance around it and where it can be easily accessed for service.
- Install the unit in an area free from drips and moisture.

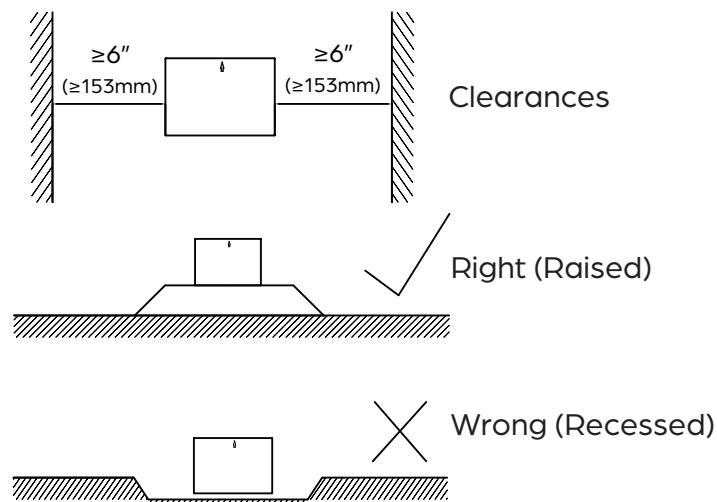

Unit Installation

Remove the cover.

1. Using a Phillips screwdriver, remove the eight (8) screws holding the cover in place and take off the cover.

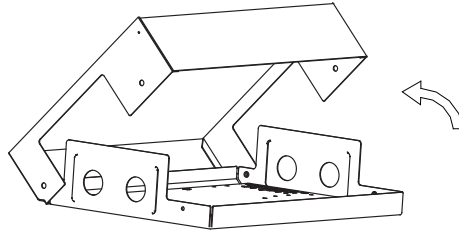

Mount the unit.

2. Mount the unit to a wall (or raised floor surface) using the three (3) screws (M4x20) and three (3) anchors.

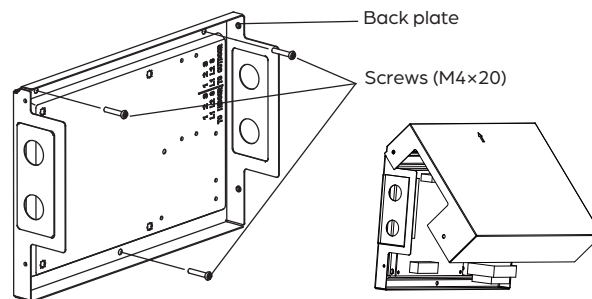

Wire the unit.

3. Wire the thermostat interface to your system and a third party thermostat, according to the instructions in the **Wiring and System Configuration** section of this manual.

Secure the unit.

4. Replace the cover and secure it, using the screws removed in the first step.

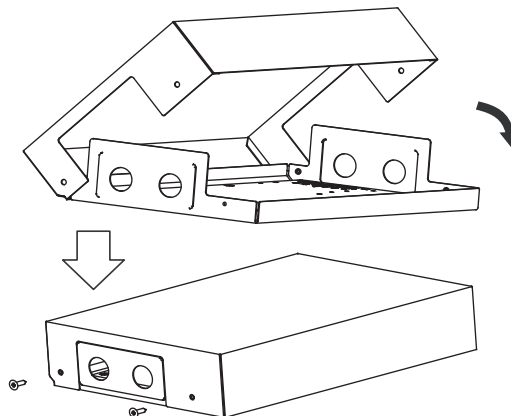

Wiring and Configuring

Wiring the third-party thermostat interface

Follow the wiring diagram below to connect this thermostat interface kit between a third-party thermostat and a Durastar system.

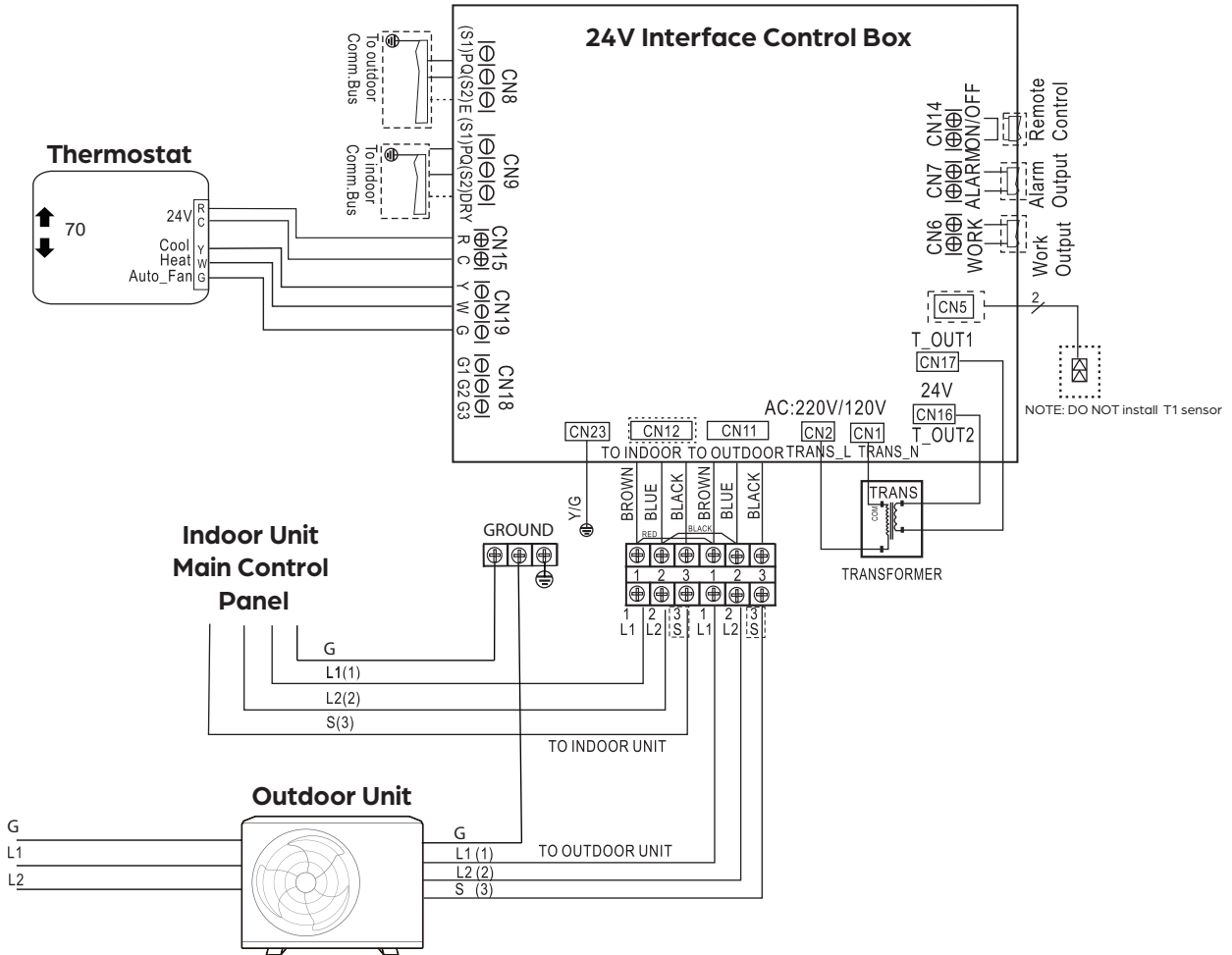

Wiring Connection Specifications

1. When using the interface with a ducted indoor unit (DRAD##F1A), the static pressure must be set up by temporarily connecting the communication wires L1(1), L2(2), and S(3) and G from the outdoor unit to the indoor unit (see the DRAD install manual or service.durastar.com). Once the static pressure setup is complete, disconnect the units from each other and proceed to step two (2). If any other IDU is used proceed directly to step two (2).
2. Connect L1(1), L2(2), and S(3) from the **outdoor** unit to terminals 1, 2 and 3 on the **right** half of the power distribution block on the interface. Connect G to a ground block (green) terminal.
3. Connect L1(1), L2(2), and S(3) from the **indoor** unit to terminals 1, 2 and 3 on the **left** half of the power distribution block on the interface. Connect G to a ground block (green) terminal.
4. Connect R and C from the 3rd party thermostat to board terminals R and C at CN15. Connect Y, W and G to wiring block terminals Y, W and G at CN19.
5. Follow the instructions in the **Configuring the DIP Switches** section to set the DIP switches in the 24V control box.
6. The thermostat must be configured for operation with a conventional system (in single stage cooling and heating). **Do not configure the thermostat for heat pump operation.**

⚠ WARNING

- All wires must meet National Electric Code (NEC) as well as local codes for proper sizes. Use the Electrical Data Table minimum circuit amps (MCA) and maximum over current protection (MOCP) to determine the proper wire sizes and fuse or breakers for the installation.

NOTE

- Only use 14/4 AWG stranded and shielded wire.
- Thermostat G to interface G is default.
- Verify power supply.
- The remote control can only be used to set the Swing and LED functions on appropriate indoor models after the thermostat interface is installed.

Configuring the DIP Switches

Follow the instructions below to configure the DIP switches on the interface's board.

For Durastar systems, both DIP switches 1-1 and 1-2 need to be set in the ON position.

The DIP switch sets are numbered from right to left.

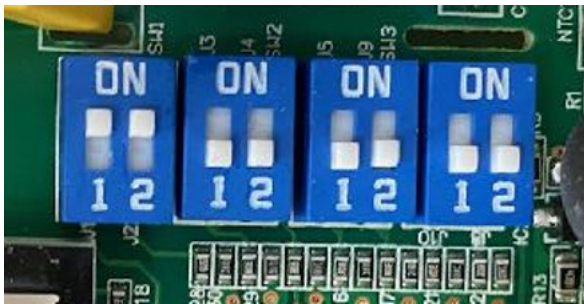

DIP Switch 1-1

This switch turns on the Control Box display.

SW 1-1	Result	Remarks
ON	Display On	Required
OFF	Display Off	Default

DIP Switch 1-2

Used to determine unit type.

SW 1-2	Result	Remarks
ON	Ductless indoor and outdoor unit.	Required
OFF	Ductless outdoor unit only.	Default

DIP Switch 2-1

This switch selects the system operation. Leave on default.

SW 2-1	Result	Remarks
ON	Cooling Only	
OFF	Heat Pump	Default

DIP Switch 2-2

This switch is used for protection of the indoor coil. Leave on default.

SW 2-2	Result	Remarks
ON	Fans do not stop	
OFF	Fans stop if indoor coil temperature is low	Default

DIP Switch 3-1

This switch is used to activate the Dry function. Leave on default.

SW 3-1	Result	Remarks
ON	Dry On	
OFF	Dry Off	Default

DIP Switch 3-2

This switch forces the Compressor to run longer if temperature not reached after one (1) hour. Leave on default.

SW 3-2	Result	Remarks
ON	+1hr	
OFF	+30 minutes	Default

DIP Switch 4-1 & DIP Switch 4-2

These switches are for factory testing purposes only. Leave on default/(OFF).

Error Codes

Error Code	Remarks
E0	Indoor EEPROM error
E2	Cross-Zero detection error
E3	Indoor fan speed malfunction
E4	Indoor room temperature sensor error
E5	Evaporator temperature sensor error
EC	Refrigerant leak detected
F0	Current overload protection
F1	Outdoor ambient temperature sensor (T4) malfunction
F2	Condenser temperature sensor (T3) malfunction
F3	Condenser temperature sensor (T5) malfunction
F4	Outdoor unit EEPROM parameter error
F5	Outdoor fan speed has been out of control
F6	T2b sensor error
P0	Inverter module (IPM) malfunction
P1	Over-voltage or under-voltage protection
P2	Compressor high temperature protection (OLP)
P3	Low ambient temperature cut off in heating
P4	Compressor drive malfunction
P6	Compressor low-pressure protection
00	Module boot mode and indoor running mode for power off
IN	Module and indoor unit communication malfunction
OU	Module and outdoor unit communication malfunction

Wiring Diagram

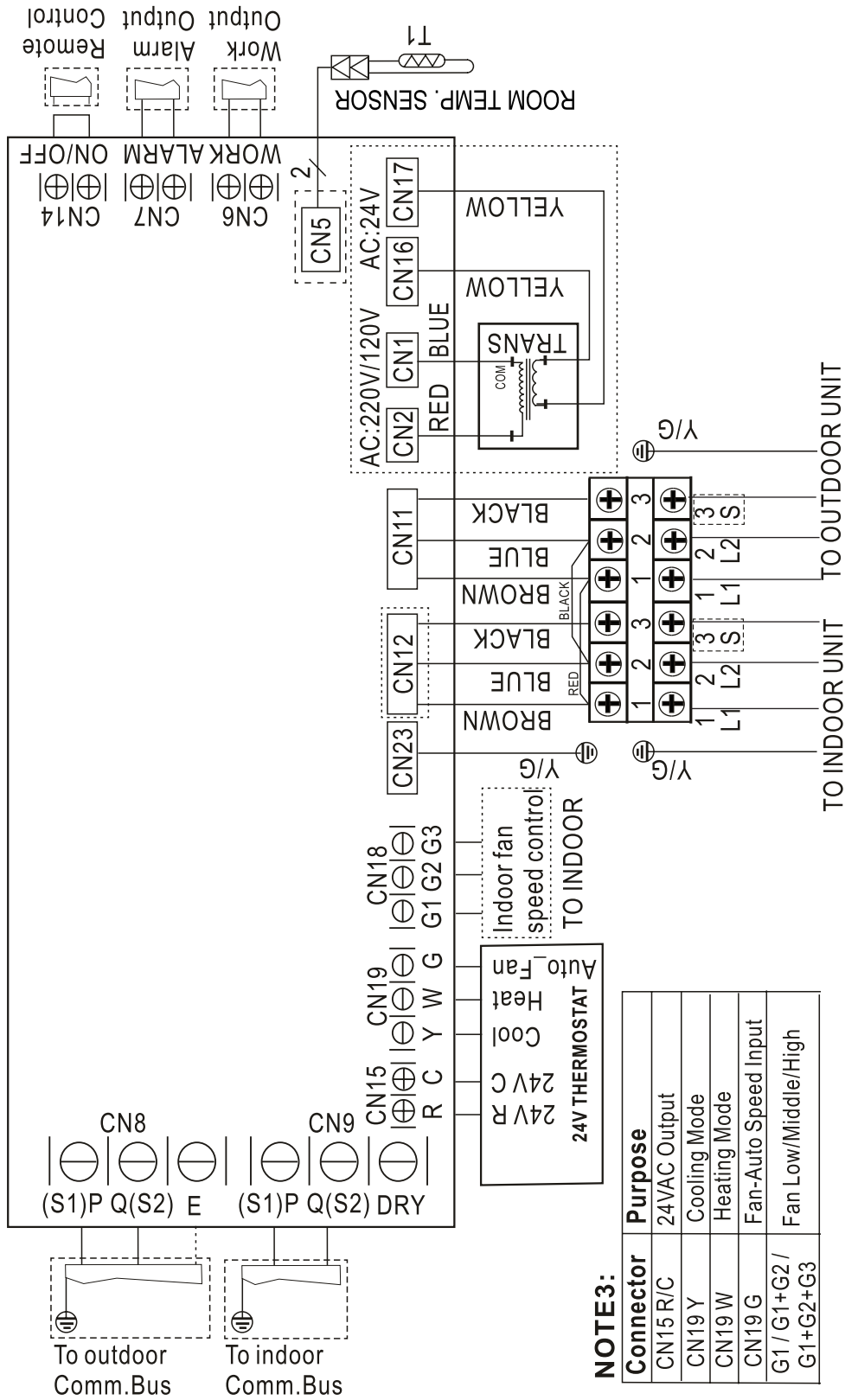

NOTE3:

Connector	Purpose
CN15 R/C	24VAC Output
CN19 Y	Cooling Mode
CN19 W	Heating Mode
CN19 G	Fan-Auto Speed Input
G1 / G1+G2 / G1+G2+G3	Fan Low/Middle/High

LIMITED WARRANTY – PARTS

TEN (10) YEARS PARTS

Subject to all of the terms of this Limited Warranty, including, but not limited to, the specific exclusions set forth below and subject to the Manufacturer's right to inspect and validate the warranty claim as set forth below, Manufacturer will repair or replace, at its option, ANY PART of Covered Equipment that is found to be defective in materials or workmanship. If an exact replacement part is not available, an equivalent part or credit will be provided.

The parts are warranted for a period of ten (10) years to the original owner of the mini-split equipment under normal use and service. For a period of ten (10) years from the date of installation, if any parts prove defective due to improper workmanship and/or material, Durastar will replace any defective part without charge for the part. Replacement parts carry the balance of the original warranty.

To qualify:

- The mini-split equipment must be installed in a residential single-family home.*
- The original mini-split equipment owner must reside in the single-family home.
- The mini-split equipment must be properly installed. This includes installation by a contractor licensed for HVAC installation following all local and state laws.
- Any part to be replaced must be made available in exchange for the replacement.

*Single-family home is defined as any single-family dwelling, which includes apartments, condominiums, duplexes, and homes.

EFFECTIVE DATE OF WARRANTY

The Effective Date of warranty coverage is determined as follows: (a) If the original installation date can be verified by the installer's invoice then the Effective Date of warranty coverage is the original installation date as shown on the installer's invoice. For residential new construction installations, the final occupancy permit, or proof of purchase from the builder can be substituted for the installer's invoice. (b) if the original installation date cannot be verified by the installer's invoice, or proof of purchase from the builder in residential new construction applications, then the Effective Date of warranty coverage is the Covered Equipment's manufacture date (as verified by the product's serial number) plus ninety (90) days.

There is NO LABOR component provided with this warranty. This Limited Warranty does NOT cover any labor costs or expenses for service, NOR for removing or reinstalling parts. You are responsible for all labor costs or expenses, unless a labor service agreement exists between you and your contractor.

This Limited Warranty does NOT cover shipping costs. You are responsible for the cost of shipping warranty replacement parts from our factory to the Manufacturer's distributor and from the distributor to the location of your Covered Equipment. You also are responsible for the cost of shipping failed parts to the distributor and for incidental costs incurred locally, including handling charges. (If in Alaska, Hawaii or Canada, you also must pay the shipping costs of returning the failed part to the port of entry into the continental United States.)

EXCLUSIONS

In addition to the other exclusions identified in this Limited Warranty, this Limited Warranty excludes:

- Damages, malfunctions, or failures resulting from failure to properly install, operate, or maintain Covered Equipment in accordance with the Manufacturer's instructions.
- Damages, malfunctions, or failures resulting from misuse, accident, contaminated, or corrosive atmosphere, vandalism, freight damage, fire, flood, freeze, lightning, acts of war, acts of God and the like.
- Parts installed with Covered Equipment or used in connection with normal maintenance, such as cleaning or replacing air filters, refrigerant, thermostats, tubing, or concrete pads.
- Covered Equipment that is not installed in the United States.



- Covered Equipment that is not installed by a qualified, trained HVAC professional in accordance with applicable codes, ordinances, and good trade practices.
- Damages, malfunctions, or failures resulting from the use of any attachment, accessory, or component not authorized by the Manufacturer or resulting from alteration or modification of the unit.
- Covered Equipment moved from the original installation location.
- Covered Equipment when operated with system components (indoor unit, outdoor unit, coil, and refrigerant control devices) or accessories which do not match or meet the specifications recommended by the Manufacturer.
- Any Covered Equipment manufactured that has been sold to the consumer via the Internet or auction website, and has not been installed by a trained, qualified HVAC professional.
- Covered Equipment that is not part of a properly matched system as specified by the Air Conditioning, Heating & Refrigeration Institute (AHRI).

COMMERCIAL WARRANTY

Installations in commercial applications carry a FIVE (5) YEAR PARTS warranty following the other provisions in this Limited Warranty.

OBTAINING WARRANTY SERVICE

If you believe your product is defective, contact the licensed contractor who installed your mini-split system. Alternatively, contact a licensed contractor, dealer, or distributor.

Durastar Customer Support is available for troubleshooting assistance. Before contacting Customer Support, please locate your model number, serial number, and proof of purchase. These items will be required to complete any warranty service. A Durastar authorized representative will verify warranty eligibility and determine appropriate service options. Service will be provided during normal business days and hours.

THIS WARRANTY IS IN LIEU OF ANY OTHER WARRANTY, EXPRESS OR IMPLIED, INCLUDING WITHOUT LIMITATION, ANY WARRANTY OF MERCHANTABILITY OR FITNESS FOR A PARTICULAR PURPOSE. TO THE EXTENT ANY IMPLIED WARRANTY IS REQUIRED BY LAW, IT IS LIMITED IN DURATION TO THE EXPRESS WARRANTY PERIOD ABOVE. NEITHER THE MANUFACTURER NOR ITS DISTRIBUTORS SHALL BE LIABLE FOR ANY INCIDENTAL, CONSEQUENTIAL, INDIRECT, SPECIAL, OR PUNITIVE DAMAGES OF ANY NATURE, INCLUDING WITHOUT LIMITATION, LOST REVENUES OR PROFITS, OR ANY OTHER DAMAGE WHETHER BASED IN CONTRACT, TORT, OR OTHERWISE. IN NO EVENT AND UNDER NO CIRCUMSTANCE OF ANY TYPE OR KIND SHALL THE SELLER, MANUFACTURER AND/OR DISTRIBUTOR BE LIABLE FOR ANY REASON, UNDER ANY THEORY, FOR MORE THAN THE BASIC COST OF THE PRODUCT TO THE PURCHASER OR END USER. SOME STATES DO NOT ALLOW THE EXCLUSION OF INCIDENTAL OR CONSEQUENTIAL DAMAGES, SO THE ABOVE EXCLUSION MAY NOT APPLY TO YOU. THIS WARRANTY GIVES YOU SPECIFIC LEGAL RIGHTS. YOU MAY HAVE OTHER RIGHTS THAT VARY FROM STATE TO STATE.