

INSTALLATION MANUAL

**WALL MOUNTED INDOOR UNIT
SPLIT-STYLE AIR CONDITIONER**

DRAW06F1B, DRAW09F1B, DRAW12F1B,
DRAW18F1B, DRAW24F1B, DRAW33F1B

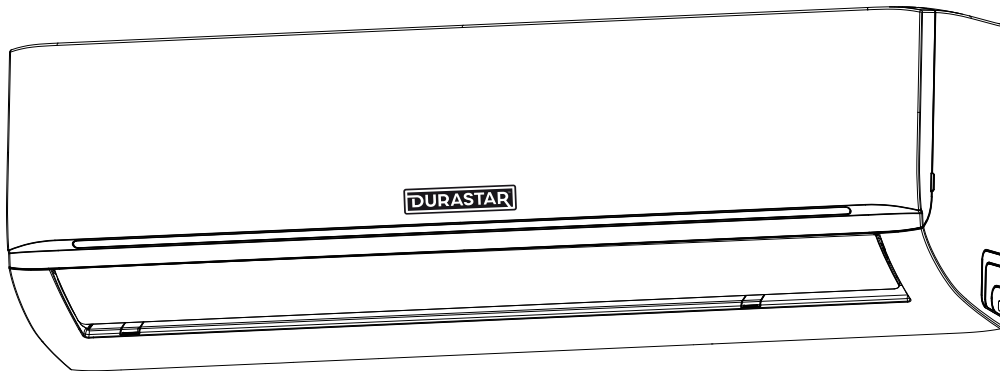

Model Number:

Serial Number:

Purchase Date:

Installing Contractor Company Name:



TIP

Capture relevant information about your Durastar mini-split equipment before it is installed and write it above for future reference.

TABLE OF CONTENTS

TABLE OF CONTENTS.....	2
INTRODUCTION	3
WARNINGS	3
IMPORTANT SAFETY PRECAUTIONS	4
OPERATING TEMPERATURES.....	7
ACCESSORIES.....	8
PARTS IDENTIFICATION.....	10
INSTALLATION OVERVIEW - INDOOR UNIT	11
INDOOR UNIT INSTALLATION	12
STEP 1: SELECT INSTALLATION LOCATION	12
STEP 2: ATTACH MOUNTING PLATE TO WALL.....	12
STEP 3: DRILL WALL HOLE FOR CONNECTIVE PIPING	13
STEP 4: PREPARE REFRIGERANT PIPING.....	14
STEP 5: CONNECT THE DRAIN PIPE	15
STEP 6: CONNECT SIGNAL CABLE	16
STEP 7: PREPARE REFRIGERANT PIPING	18
STEP 8: WRAPPING THE CABLES.....	18
STEP 9: MOUNT INDOOR UNIT.....	18
TROUBLESHOOTING.....	20
WIRING DIAGRAM.....	24
ERROR AND OPERATING CODES.....	27

INTRODUCTION

To better serve you, please do the following before contacting customer service:

- If you received a damaged product, immediately contact the retailer or dealer that sold you the product.
- Read and follow this owner's manual carefully to help you use and maintain your air conditioner.
- Read the troubleshooting section of this manual as it will help you diagnose and solve common issues.
- Visit us on the web at www.durastar.com to download product guides and up-to-date information.
- If you need warranty service, our friendly customer service representatives are available via email at questions@durastar.com or by telephone at 1-888-320-0706.

WARNINGS

Symbols Used in This Manual



The warning symbol indicates cautionary information for the user. Extra care and precautions should be taken to ensure the user's safety.



The pencil indicates any manufacturer notes relating to surrounding content. These may include further clarifications or call-outs.



A light bulb symbol indicates suggested manufacturer tips for the user to get the most out of the Durastar equipment and to accommodate the best user experience.

IMPORTANT SAFETY PRECAUTIONS

Improper handling can cause serious damage or injury. Please read the following safety information in its entirety.



Operation, Cleaning, and Maintenance Safety Precautions

- Children and people with reduced physical, sensory, or mental capabilities, or lack of experience and knowledge, should only use this air conditioner if they are given supervision or instructions concerning use of the air conditioner in a safe way and understand the hazards involved.
- Children should not play with the air conditioner.
- Never stick fingers or any other body parts into the air conditioner openings. The internal fan may be rotating at high speeds, and may result in injury.
- After removing the filter, do not touch the fins in order to avoid injury.
- Maintenance must be performed by qualified professionals. Otherwise, you may experience personal injury or damage to the air conditioner and surrounding property.
- Do not repair the air conditioner by yourself. It may cause electric shock or damage. Please contact a qualified service representative when you need to repair the air conditioner.
- Do not block the air outlet or air inlet. This could cause a malfunction.
- Do not spill water on the remote control as this can permanently damage the remote.
- If the below problems occur, please turn off the air conditioner and disconnect power at the circuit breaker immediately. Then contact your dealer or a qualified professional for service.
 - The power cord is overheating or damaged.
 - There is an abnormal sound during operation.
 - The circuit breaker trips frequently.
 - The air conditioner gives off a burning smell.
 - The indoor unit is leaking.
- If the air conditioner operates under abnormal conditions, it may cause malfunctions, electric shock, or fire hazard.
- When turning the unit on or off via the emergency operation switch, press the switch with an insulated object other than metal.
- Do not step on the top panel of the unit, or put heavy objects on the top panel. This could cause damage or personal injury.
- Cleaning and user maintenance should not be performed by children without supervision.
- Do not spray water on the indoor unit. This could cause electric shock or a unit malfunction.
- Do not use flammable materials such as hair spray, lacquer, or paint near the air conditioner as they may catch fire.
- Do not operate the air conditioner in places near combustible gases. Emitted gases may collect around the air conditioner and cause an explosion.
- Do not use fire or a hair dryer to dry the filter. This could cause a deformation or fire hazard.
- Do not wash the air conditioner with water as this could cause an electric shock.
- Disconnect the power supply by turning it off at the circuit breaker when cleaning the air conditioner. Otherwise, you could risk electric shock.



Electrical Safety

- Do not modify the length of the power supply cord or use an extension cord to power the unit.
- If the supply cord is damaged, it must be replaced by the manufacturer, a service agent, or a similarly qualified person in order to avoid a safety hazard.
- Do not share the electrical outlet with other appliances. Improper or insufficient power supply can cause fire or electrical shock.
- The product must be properly grounded at the time of installation, or electrical shock may occur.
- For all electrical work, follow all local and national wiring standards and regulations. Connect cables tightly, and clamp them securely to prevent external forces from damaging the terminal. Improper electrical connections can overheat and cause fire, and may also cause shock. All electrical connections must be made according to the Electrical Connection Diagram located on the panels of the indoor and outdoor units.
- All wiring must be properly arranged to ensure that the control board cover can close properly. If the control board cover is not closed properly, it can lead to corrosion and cause the connection points on the terminal to heat up, catch fire, or cause electrical shock.
- The air conditioner's circuit board (PCB) is designed with a fuse to provide overcurrent protection. The specifications of the fuse are printed on the circuit board.

Installation Safety

- Installation must be performed by an authorized dealer or specialist. Improper installation can cause water leakage, electrical shock, or fire. (In North America, installation must be performed in accordance with NEC and CEC requirements by authorized personnel only.)
- Installation must be performed according to the installation instructions. Improper installation can cause water leakage, electrical shock, or fire.
- This air conditioner shall be installed in accordance with national and local wiring regulations.
- Contact an authorized service technician for repair or maintenance of this unit.
- Only use the included accessories, parts, and specified parts for installation. Using non-standard parts can cause water leakage, electrical shock, fire, and can cause the unit to fail.
- Install the unit in a firm location that can support the unit's weight. If the chosen location cannot support the unit's weight, or the installation is not done properly, the unit may fall and cause serious injury and damage.
- Install drainage piping according to the instructions in the installation manual. Improper drainage may cause water damage to your home and property.
- Do not install the unit in a location that may be exposed to combustible gas leaks. If combustible gas accumulates around the unit, it may cause a fire.
- Do not turn on the power until all work has been completed.
- When moving or relocating the air conditioner, consult experienced service technicians for disconnection and re-installation of the unit.

Additional Precautions

- Turn off the air conditioner and disconnect the power if you are not going to use it for a long time.
- Turn off the unit during electrical storm to avoid damaging the unit.
- Make sure that water condensation can drain unhindered from the unit.
- Do not operate the air conditioner with wet hands. This may cause electric shock.
- Do not use this device for any other purpose than its intended use.
- Do not climb onto or place objects on top of the outdoor unit.
- Do not allow the air conditioner to operate for long periods of time with doors or windows open, or if the humidity is very high.

OPERATING TEMPERATURES

Your air conditioner is designed to operate in the following indoor and outdoor temperatures. When your air conditioner is used outside of the following temperature ranges, certain safety features may activate and turn off the unit to protect it from damage.

TEMPERATURE RANGES

	COOL mode	HEAT mode	DRY mode
Indoor Air Temperature	60°F - 90°F (16°C - 32°C)	32°F - 86°F (0°C - 30°C)	50°F - 90°F (10°C - 32°C)
Outdoor Air Temperature	5°F - 122°F (-15°C - 50°C)	-13°F - 75°F* (-25°C - 24°C)*	32°F - 122°F (0°C - 50°C)

* The minimum operating temperature depends on the outdoor unit. Low ambient models have a minimum operating temperature in heat mode of -22°F (-30°C).

To further optimize the performance of your unit, do the following:

- Keep doors and windows closed.
- Limit energy usage by using TIMER ON and TIMER OFF features.
- Do not block air inlets or outlets.
- Regularly inspect and clean air filters.

NOTE

 Your Durastar air conditioner's outdoor unit is equipped with a base pan heater, allowing it to continue to operate at freezing temperatures as low as -22°F (-30°C). When outdoor air temperatures are at or below 32°F (0°C), we strongly recommend keeping the unit plugged in at all times to ensure smooth ongoing performance.









NOTE

 Keep the room's relative humidity below 80%. If the air conditioner operates in excess of this, the surface of the air conditioner may attract condensation. To help prevent condensation from forming and dripping, set the vertical airflow louver to its maximum angle (vertically to the floor) and set the fan to HIGH.

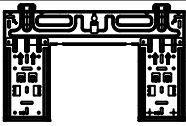
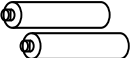
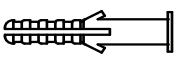
ACCESSORIES

INCLUDED INSTALLATION ACCESSORIES

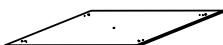
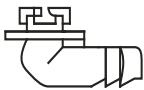
The air conditioning system comes with the following accessories.

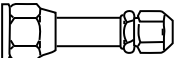
Accessory	Quantity	Image	Accessory	Quantity	Image
Manual	1-2		Remote Control	1	
Mounting Plate	1		Battery	2	
Wall Anchor	5-8 (depending on model)		Remote Control Holder	1	
Mounting Plate Screw	5-8 (depending on model)		Remote Control Holder Mounting Screw	2	
Copper Nut	2		Installation Template	1	
Drain Joint	1		Carbon Filter	2	
Drain Joint Seal	1		Refrigerant Pipe Adapter (included with DRAW33F1B)	1	 3/4" -> 5/8"

NOTE



When the DRAW33F1B indoor unit is installed with a multi-zone outdoor unit, you must purchase refrigerant pipe with a liquid side size of $\Phi 3/8$ in ($\Phi 9.52$ mm) and a gas side size of $\Phi 5/8$ in ($\Phi 16$ mm). The refrigerant pipe adaptor included with the indoor unit must be installed on the indoor unit.

FIELD SUPPLIED INSTALLATION ACCESSORIES

The following installation accessories are required and must be purchased separately.

- Refrigerant piping (line set)
- Indoor and outdoor connection wire
- Outdoor power supply cord
- Drain pipe
- Pipe and cable wrapping tape
- Wall hole sleeve and cover
- Putty
- Wiring u-lugs

TOOLS NEEDED

The following tools are required for installation.

- Phillips screwdriver
- Drill with 2 1/2" or 3 1/2" (indoor unit model depending) core bit
- Vacuum pump
- HVAC manifold gauge set
- Micron Gauge
- Refrigerant leak detector
- Copper pipe cutter
- Flaring tool
- Burr reamer
- Crescent or spanner wrench
- Hexagonal wrench set
- Torque wrench
- Multimeter
- Electroprobe
- Level
- Hammer
- Wire strippers
- Wire crimper

PARTS IDENTIFICATION



NOTE

The installation must be performed in accordance with the required local and national standards. The installation may be slightly different in different areas.

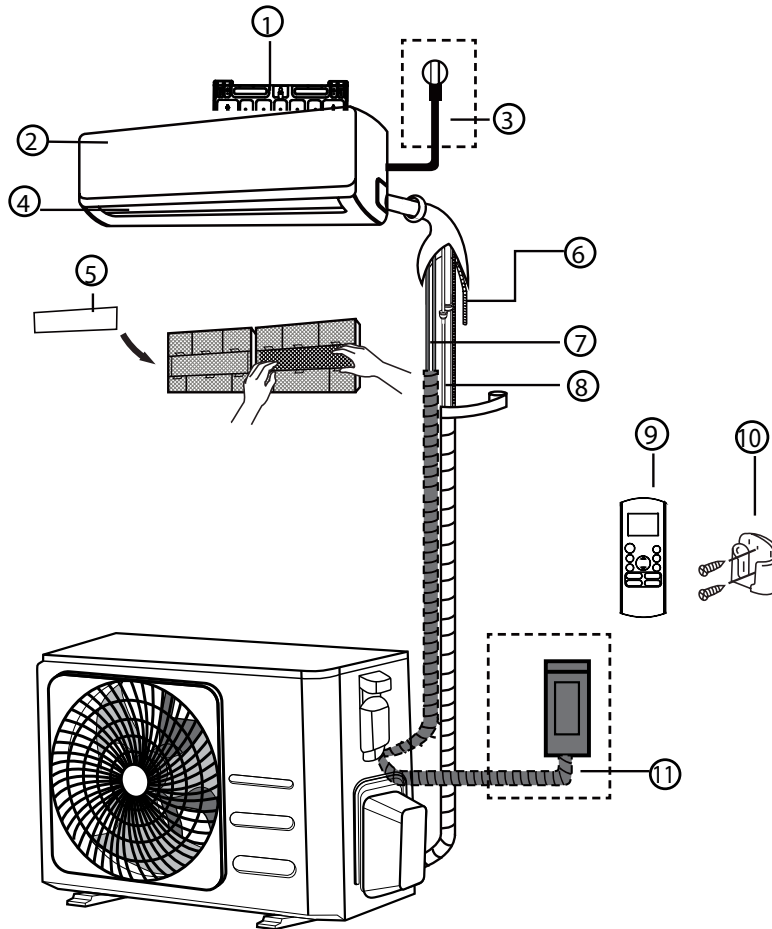

- ① Wall Mounting Plate
- ② Front Panel
- ③ Power Cable
- ④ Louver

- ⑤ Air Freshness (Carbon) Filter
- ⑥ Drainage Pipe
- ⑦ Signal Cable
- ⑧ Refrigerant Piping

- ⑨ Remote Controller
- ⑩ Remote controller Holder
- ⑪ Outdoor Unit Power Cable



NOTE

Illustrations in this manual are for explanatory purposes. The actual shape of your mini-split equipment may vary slightly.

INSTALLATION OVERVIEW – INDOOR UNIT

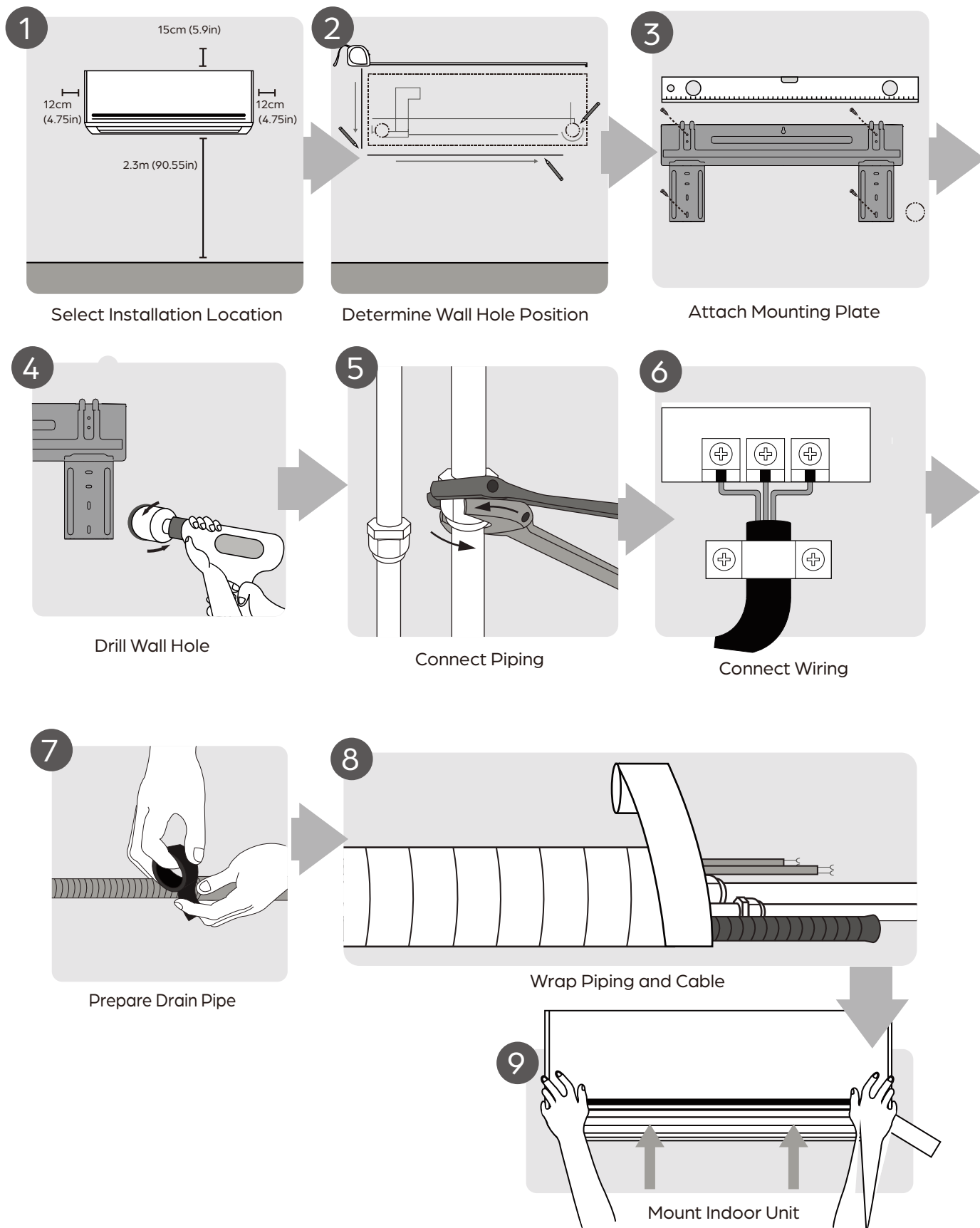

INDOOR UNIT INSTALLATION

STEP 1: SELECT INSTALLATION LOCATION

Before installing the indoor unit, you must choose an appropriate location. The following standards must be met for an appropriate location for the unit:

- Good air circulation
- Convenient drainage
- Noise from the unit will not disturb other people
- Firm and solid – the location will not vibrate
- Strong enough to support the weight of the unit
- A location at least three feet (one meter) from all other electrical devices (e.g., TV, radio, computer)

DO NOT install unit in the following locations:

- Near any source of heat, steam, or combustible gas
- Near flammable items such as curtains or clothing
- Near any obstacle that might block air circulation
- Near a doorway
- In a location subject to direct sunlight

Refer to the following diagram to ensure proper distance from walls and ceiling:

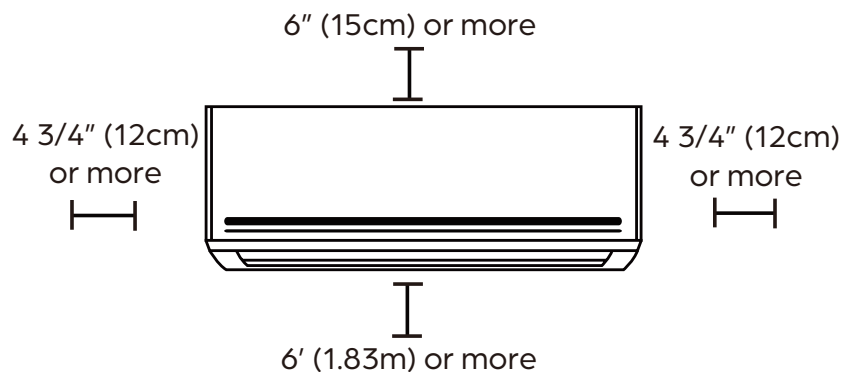

NOTE

If there is no pre-existing refrigerant piping, when choosing a location, leave ample room for a wall hole (see *Step 3: Drill Wall Hole for Connective Piping*) for the signal cable and refrigerant piping that connect the indoor and outdoor units. The default position for all piping is the right side of the indoor unit (while facing the unit). However, the unit can accommodate piping to either the left or right.

STEP 2: ATTACH MOUNTING PLATE TO WALL

1. Remove the screw that attaches the mounting plate to the back of the indoor unit. The mounting plate is the bracket on which you will mount the indoor unit.

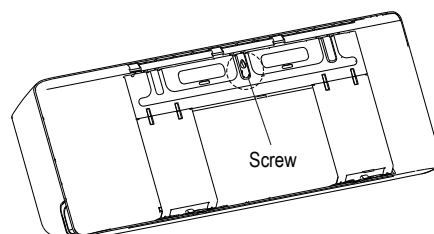

- Secure the mounting plate to the wall with the anchors and screws provided. Make sure that mounting plate is flat against the wall, and is level.

Correct orientation of mounting plate

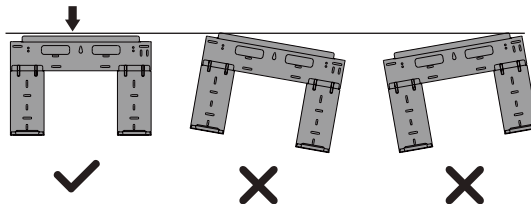

NOTE



If the wall is made of brick, concrete, or similar material, drill 5mm-diameter (0.2in diameter) holes in the wall and insert the sleeve anchors provided. Then secure the mounting plate to the wall by tightening the screws directly into the clip anchors.

STEP 3: DRILL WALL HOLE FOR CONNECTIVE PIPING

- Determine the location of the wall hole based on your unit's mounting plate dimensions. Use the installation template provided with the indoor unit to correctly position the wall hole, or refer to the illustration below.

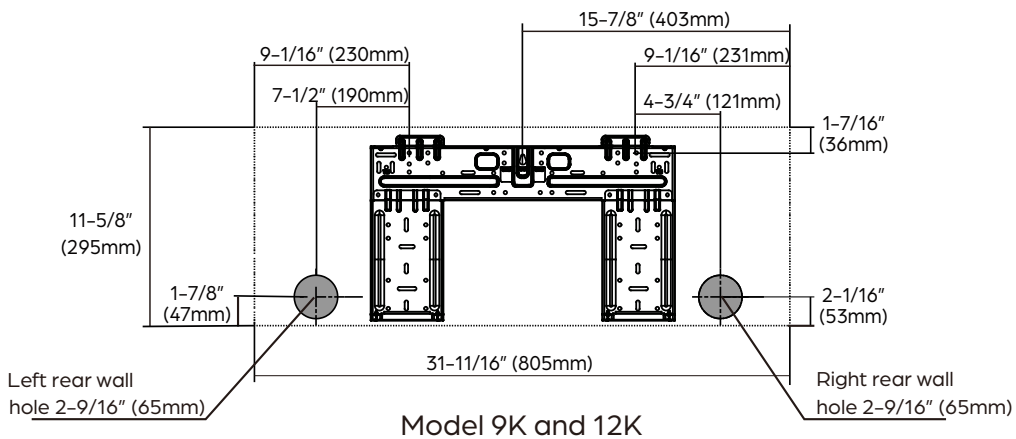

Model 9K and 12K

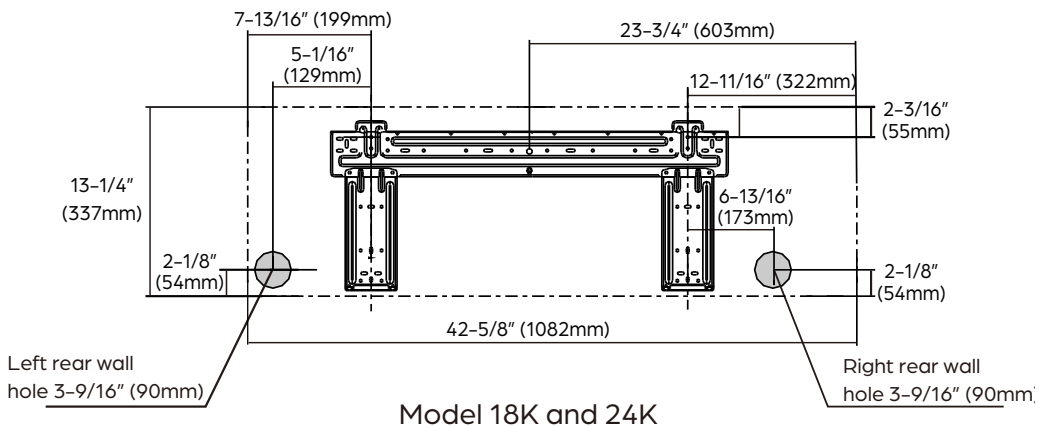

Model 18K and 24K

NOTE



When the gas side connective pipe is 16mm(5/8in) or more, the wall hole should be 3-9/16" (90mm).

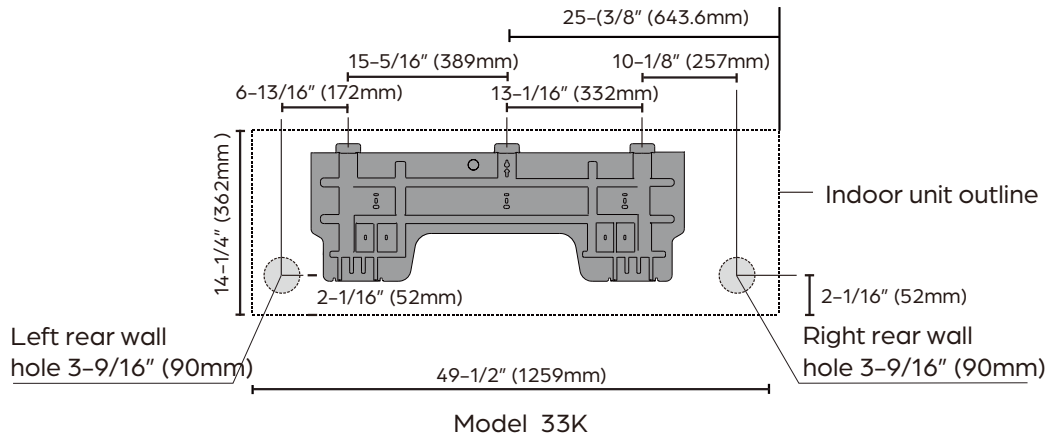

- Using a 2-1/2" (65mm) core drill for units with a gas side connective pipe less than 5/8" (16mm), or 3-1/2" (90mm) for units with a gas side pipe greater than or equal to 5/8" (16mm), drill a hole in the wall. Make sure that the hole is drilled at a slight downward angle, so that the outdoor end of the hole is lower than the indoor end by about 3/16 - 1/4" (5mm to 7mm). This will ensure proper water drainage.

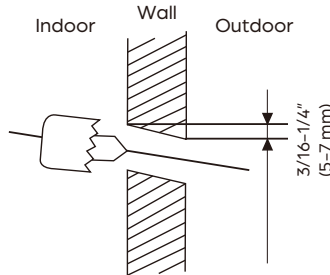

- Place the protective wall hole sleeve into the hole. This protects pipes and cables from sharp edges and will help seal the opening when you finish the installation process. After the sleeve is inserted through the wall, connect the wall hole cover to the wall sleeve on the outside end. Make sure the cover is flush with the outside wall.

STEP 4: PREPARE REFRIGERANT PIPING

- Based on the position of the wall hole relative to the mounting plate, choose the side from which the piping will exit the unit (left or right).
- If the wall hole is behind the unit, do not remove the knock-out panel. If the wall hole is to the side of the indoor unit, remove the plastic knock-out panel from that side of the unit. This will create a slot through which your piping can exit the unit. Use needle nose pliers or cutters if the plastic panel is too difficult to remove by hand. Grooves have been made in the knock-out panel in order to cut it to size conveniently. The size of the piece removed is determined by the diameter of the piping.

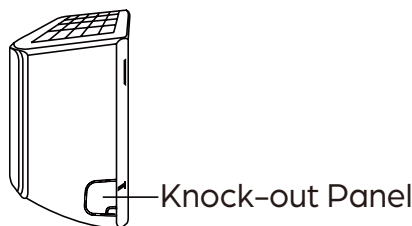

- If pre-existing connective piping is already embedded in the wall, proceed directly to *Step 5: Connect the Drain Pipe*. If there is no pre-existing piping, connect the indoor unit's refrigerant piping to the connective piping that will join the indoor and outdoor units. Refer to the *Refrigerant Piping Connections* section of your outdoor unit's installation manual for detailed instructions.

4. Position the piping to align with the wall hole. The refrigerant piping can exit the indoor unit from four different angles: left-hand side, right-hand side, left rear, or right rear.

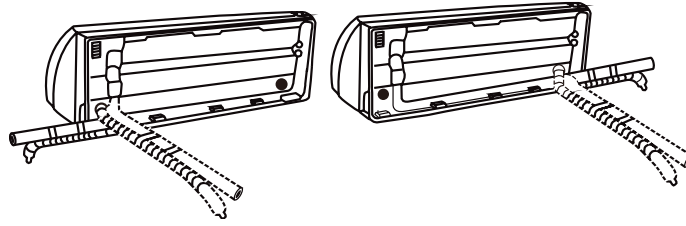

WARNING

Be extremely careful not to dent or damage the piping while bending them away from the unit. Any dents in the piping will affect the unit's performance.

STEP 5: CONNECT THE DRAIN PIPE

By default, the unit's drain pipe is attached to the left-hand side of unit (when you're facing the back of the unit). However, it can also be attached to the right-hand side. To ensure proper drainage, attach the drain pipe on the same side that your refrigerant piping exits the unit. Attach any drain pipe extension (purchased separately) to the end of the drain pipe. Any drain pipe extension must have an inner diameter of 5/8" (16mm) and tightly fit the unit's existing drain pipe.

- Wrap the connection point firmly with Teflon tape to ensure a good seal and to prevent leaks.
- For the portion of the drain pipe that will remain indoors, wrap it with foam pipe insulation to prevent condensation.
- Remove the air filter and pour a small amount of water into the drain pan to make sure that water flows from the unit smoothly.
- Make sure to arrange the drain pipe according to the following illustration.

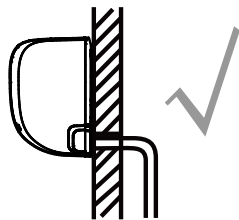

CORRECT

Make sure there are no kinks or dents in drain pipe to ensure proper drainage.

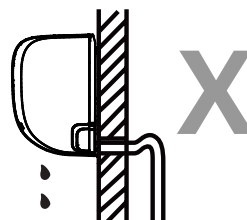

NOT CORRECT

Kinks in the drain pipe will create water traps.

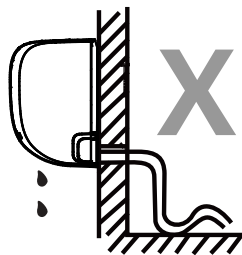

NOT CORRECT

Kinks in the drain pipe will create water traps.

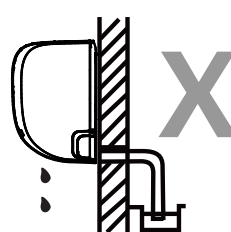

NOT CORRECT

Do not place the end of the drain pipe in water or in containers that collect water. This will prevent proper drainage.

**WARNING**

PLUG THE UNUSED DRAIN HOLE. To prevent unwanted leaks you must plug the unused drain hole with the rubber plug provided.

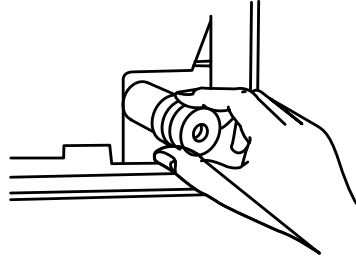
**STEP 6: CONNECT SIGNAL CABLE****BEFORE PERFORMING ANY ELECTRICAL WORK, READ THESE REGULATIONS**

1. All wiring must comply with local and national electrical codes and regulations, and must be installed by a licensed electrician.
2. All electrical connections must be made according to the Electrical Connection Diagram located on the panels of the indoor and outdoor units.
3. If there is a serious safety issue with the power supply, stop work immediately and contact a licensed electrician. Do not continue with the installation until the safety issue is properly resolved.
4. Power voltage should be within 90–110% of rated voltage. Insufficient power supply can cause malfunction, electrical shock, or fire.
5. If connecting power to fixed wiring, install a surge protector and main power switch with a capacity of 1.5 times the maximum current of the unit.
6. If connecting power to fixed wiring, a switch or circuit breaker that disconnects all poles and has a contact separation of at least 1/8" (3mm) must be incorporated in the fixed wiring. A qualified technician must use an approved circuit breaker or switch.
7. Only connect the unit to an individual branch circuit outlet. Do not connect another appliance to that outlet.
8. Make sure to properly ground the air conditioner.
9. Every wire must be firmly connected. Loose wiring can cause the terminal to overheat, resulting in product malfunction and possible fire.
10. Do not let wires touch or rest against refrigerant tubing, the compressor, or any moving parts within the unit.
11. If the unit has an auxiliary electric heater, it must be installed at least 40" away from any combustible materials.
12. To avoid getting an electric shock, never touch the electrical components soon after the power supply has been turned off. After turning off the power, always wait 10 minutes or more before you touch the electrical components.

**WARNING**

Before performing any electrical or wiring work, turn off the main power to the system.

**WARNING****DO NOT MIX UP LIVE AND NULL WIRES**

This is dangerous, and can cause the air conditioning unit to malfunction.

The signal cable enables communication between the indoor and outdoor units. You must first choose the right cable size before preparing it for connection. Run a continuous length of cable and avoid splicing this cable.

CABLE SIZING

USE THE RIGHT CABLE

- Indoor Power/ Signal Cable: 14/4 stranded, unshielded
- Outdoor Power Cable: Determined by amperage of system and the local codes in your area.

Choose the correct size of cable

The size of the power supply cable, fuse, and switch needed is determined by the maximum current of the unit. The maximum current is indicated on the nameplate located on the side panel of the unit. Refer to this nameplate to choose the right cable, fuse, or switch.

Wiring the Indoor Unit

1. Open front panel of the indoor unit.
2. Using a screwdriver, open the wire box cover on the right side of the unit. This will reveal the terminal block.
3. Unscrew the cable clamp below the terminal block and place it to the side.
4. Facing the back of the unit, remove the plastic panel on the bottom left-hand side.
5. Feed the signal wire through this slot, from the back of the unit to the front.

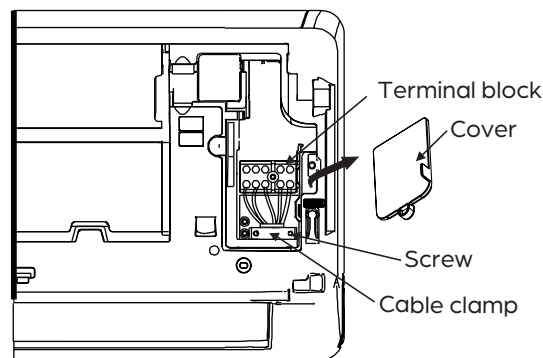

6. Connect a spade u-lug onto the end of each wire
7. Facing the front of the unit, connect the wire according to the indoor unit's wiring diagram and firmly screw each wire lug to its corresponding terminal.
8. After checking to make sure every connection is secure, use the cable clamp to fasten the signal cable to the unit. Screw the cable clamp down tightly.
9. Replace the wire cover on the front of the unit and the plastic panel on the back.



WARNING

All wiring must be performed strictly in accordance with the wiring diagram located on the back of the indoor unit's front panel.

STEP 7: PREPARE REFRIGERANT PIPING

1. If pre-existing refrigerant piping is already embedded in the wall, skip to Step 9. Then, begin the outdoor unit installation. Refer to the *Refrigerant Piping Connections* section of the outdoor unit's installation manual for detailed instructions.
2. If there is no pre-existing piping, connect the indoor unit's refrigerant piping to the connective piping that will join the indoor and outdoor units. Refer to the *Refrigerant Piping Connections* section of the outdoor unit's installation manual for detailed instructions.

STEP 8: WRAPPING THE CABLES

Before passing the piping, drain pipe, and the signal cable through the wall hole, you must bundle them together to save space, protect them, and insulate them.

1. Bundle the drain pipe, refrigerant pipes, and signal cable as shown below:

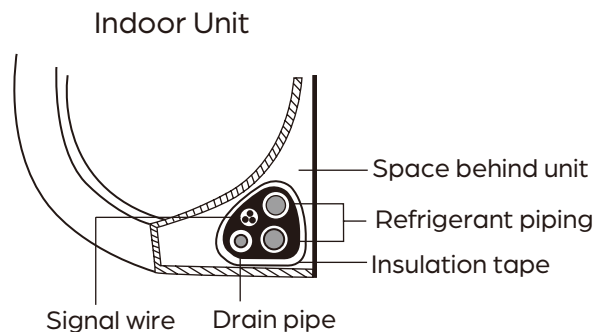

NOTE
The drain pipe **MUST** be at the bottom of the bundle. Putting the drain pipe at the top of the bundle can cause the drain pan to overflow, which can lead to fire or water damage.

NOTE
DO NOT intertwine the signal cable with any of the other wires while bundling these items together.

2. Using adhesive vinyl tape, attach the drain pipe to the underside of the refrigerant pipes.
3. Using insulation tape, wrap the signal wire, refrigerant pipes, and drain pipe tightly together. Double-check that all items are bundled.

NOTE
When wrapping the bundle, keep the ends of the piping unwrapped. You need to access them to test for leaks at the end of the installation process (refer to Electrical and Gas Leak Checks section of this manual).

STEP 9: MOUNT INDOOR UNIT

If you installed new connective piping to the outdoor unit, do the following:

1. If you have already passed the refrigerant piping through the hole in the wall, proceed to #4.
2. Double-check that the ends of the refrigerant pipes are sealed to prevent dirt or foreign materials from entering the pipes.
3. Slowly pass the wrapped bundle of refrigerant pipes, drain pipe, and signal wire through the hole in the wall.

4. Hook the top of the indoor unit on the upper hook of the mounting plate.
5. Check that the unit is hooked firmly on the mounting by applying slight pressure to the left- and right-hand sides of the unit. The unit should not jiggle or shift.
6. Using even pressure, push down on the bottom half of the unit. Keep pushing down until the unit snaps onto the hooks along the bottom of the mounting plate.
7. Again, check that the unit is firmly mounted by applying slight pressure to the left and the right-hand sides of the unit.

If refrigerant piping is already embedded in the wall, do the following:

1. Hook the top of the indoor unit on the upper hook of the mounting plate.
2. Use a bracket or wedge to prop up the unit, giving you enough room to connect the refrigerant piping, signal cable, and drain pipe.

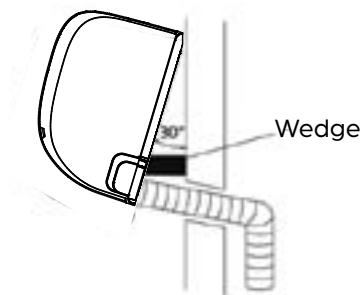

NOTE
 We recommend a second person is present to assist with supporting the indoor unit while the first person makes all applicable connections.

3. Connect drain pipe and refrigerant piping (refer to the Refrigerant Piping Connections section of the outdoor unit installation manual for instructions).
4. Keep pipe connection point exposed to perform the leak test (refer to Electrical and Gas Leak Checks section of the outdoor unit's installation manual).
5. After the leak test, wrap the connection point with insulation tape.
6. Remove the bracket or wedge that is propping up the unit, if applicable.
7. Using even pressure, push down on the bottom half of the unit. Keep pushing down until the unit snaps onto the hooks along the bottom of the mounting plate.

NOTE
 The indoor unit is adjustable. The hooks on the mounting plate are smaller than the holes on the back of the unit. If you find that you don't have ample room to connect embedded pipes to the indoor unit, the unit can be adjusted left or right by about 1-1/4-2" (30-50mm), depending on the model.

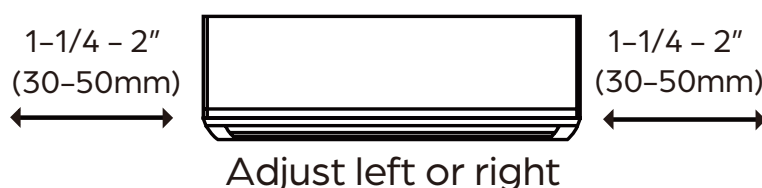

TROUBLESHOOTING

SAFETY PRECAUTIONS

If ANY of the following conditions occurs, turn off your unit immediately!

- The power cord is damaged or abnormally warm
- You smell a burning odor
- The unit emits loud or abnormal sounds
- A power fuse blows or the circuit breaker frequently trips
- Water or other objects fall into or out of the unit

DO NOT ATTEMPT TO FIX THESE YOURSELF! CONTACT AN AUTHORIZED SERVICE PROVIDER IMMEDIATELY!

COMMON ISSUES

The following problems are not a malfunction and in most situations will not require repairs.

ISSUE	POSSIBLE CAUSES
Unit does not turn on when pressing ON/OFF button	The Unit has a 3-minute protection feature that prevents the unit from overloading. The unit cannot be restarted within three minutes of being turned off.
The unit changes from COOL/HEAT mode to FAN mode	The unit may change its setting to prevent frost from forming on the unit. Once the temperature increases, the unit will start operating in the previously selected mode again.
	The set temperature has been reached, at which point the unit turns off the compressor. The unit will continue operating when the temperature fluctuates again.
The indoor unit emits white mist	In humid regions, a large temperature difference between the room's air and the conditioned air can cause white mist.
Both the indoor and outdoor units emit white mist	When the unit restarts in HEAT mode after defrosting, white mist may be emitted due to moisture generated during the defrosting process.
The indoor unit makes noises	A rushing air sound may occur when the louver resets its position.
	A squeaking sound may occur after running the unit in HEAT mode due to expansion and contraction of the unit's plastic parts.

ISSUE	POSSIBLE CAUSES
Both the indoor unit and outdoor unit make noises	Low hissing sound during operation: This is normal and is caused by refrigerant gas flowing through both indoor and outdoor units.
	Low hissing sound when the system starts, has just stopped running, or is defrosting: This noise is normal and is caused by the refrigerant gas stopping or changing direction.
	Squeaking sound: Normal expansion and contraction of plastic and metal parts caused by temperature changes during operation can cause squeaking noises.
The outdoor unit makes noises	The unit will make different sounds based on its current operating mode.
Dust is emitted from either the indoor or outdoor unit	The unit may accumulate dust during extended periods of non-use, which will be emitted when the unit is turned on. This can be mitigated by covering the unit during long periods of inactivity.
The unit emits a bad odor	The unit may absorb odors from the environment (such as furniture, cooking, cigarettes, etc.) which will be emitted during operations.
	The unit's filters have become moldy and should be cleaned.
The fan of the outdoor unit does not operate	During operation, the fan speed is controlled to optimize product operation.
Operation is erratic, unpredictable, or unit is unresponsive	Interference from cell phone towers and remote boosters may cause the unit to malfunction. In this case, try the following: <ul style="list-style-type: none"> • Disconnect the power, then reconnect. • Press ON/OFF button on remote control to restart operation.

NOTE



If problem persists, contact a local dealer or your nearest customer service center. Provide them with a detailed description of the unit malfunction as well as your model number.

TROUBLESHOOTING

When troubles occur, please check the following points before contacting a repair company.

PROBLEM	POSSIBLE CAUSES	SOLUTION
Poor Cooling Performance	Temperature setting may be higher than ambient room temperature.	Lower the temperature setting.
	The heat exchanger on the indoor or outdoor unit is dirty.	Clean the affected heat exchanger.
	The air filter is dirty.	Remove the filter and clean it according to instructions.
	The air inlet or outlet of either unit is blocked.	Turn the unit off, remove the obstruction and turn it back on.
	Doors and windows are open.	Make sure that all doors and windows are closed while operating the unit.
	Low refrigerant due to leak or long-term use.	Check for leaks, re-seal if necessary and top off refrigerant.
	Excessive heat is generated by sunlight.	Block sunlight in installation area. Close windows and curtains during periods of high heat or bright sunshine.
	Too many sources of heat in the room (people, computers, electronics, etc.).	Reduce amount of heat sources.
	Low refrigerant due to leak or long-term use.	Check for leaks, re-seal if necessary and top off refrigerant.
	SILENCE function is activated	SILENCE function can lower product performance by reducing operating frequency. Turn off SILENCE function.
Poor Heating Performance	The outdoor temperature is extremely low.	This model is designed to work down to -13°F, however, heating performance is impacted at temperatures below freezing.
	Cold air is entering through doors and windows.	Make sure that all doors and windows are closed during use.
	Low refrigerant due to leak or long-term use.	Check for leaks, re-seal if necessary, and top off refrigerant.
The unit starts and stops frequently	There's too much or too little refrigerant in the system.	Check for leaks and recharge the system with refrigerant.
	Incompressible gas or moisture has entered the system.	Evacuate and recharge the system with refrigerant.
	The compressor is broken.	Replace the compressor.
	The voltage is too high or too low.	Install a manostat to regulate the voltage.

PROBLEM	POSSIBLE CAUSES	SOLUTION
The unit is not working	Power failure.	Wait for the power to be restored.
	The power is turned off.	Turn on the power.
	The fuse is burned out.	Replace the fuse.
	Remote control batteries are dead.	Replace the batteries.
	The Unit's 3-minute protection has been activated.	Wait three minutes after restarting the unit.
	Timer is activated.	Turn timer off.
Indicator lamps continue flashing	<p>The unit may stop operation or continue to run safely. If the indicator lamps continue to flash or error codes appear, wait for about 10 minutes. The problem may resolve itself.</p> <p>If not, disconnect the power, then connect it again. Turn the unit on.</p> <p>If the problem persists, disconnect the power and contact your nearest customer service center.</p>	



NOTE

If your problem persists after performing the checks and diagnostics above, turn off your unit immediately and contact an authorized service center.

WIRING DIAGRAM

DRAW06F1B

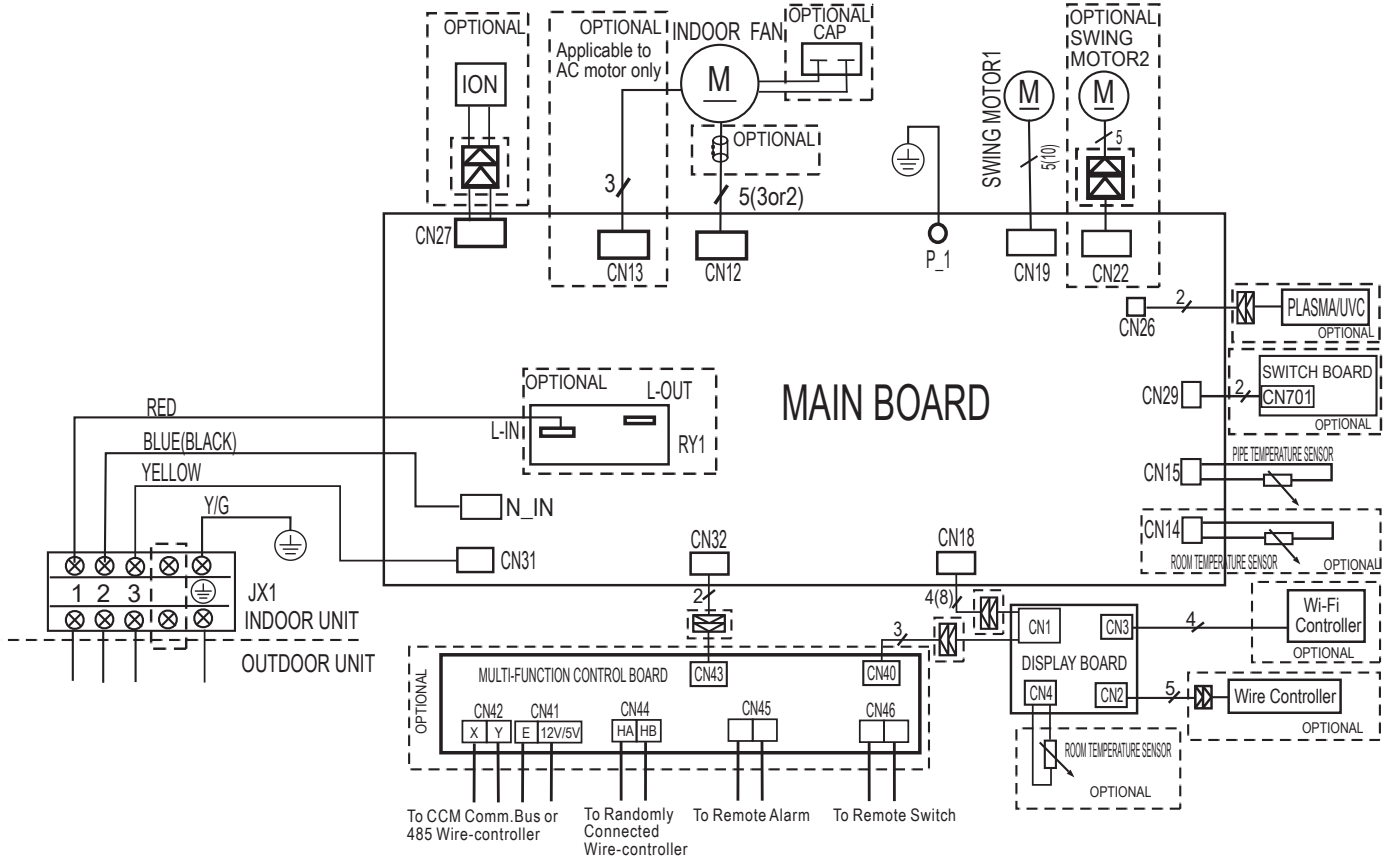

FOR SETTING NETADDRESS (CCM Comm.Bus)

---- This symbol indicates the element is optional, the actual shape shall prevail.

CODE	0~F	0~F	0~F	0~F
NETADDRESS	0~15	16~31	32~47	48~63
FACTORY SETTING	✓			

DRAW09F1B and DRAW12F1B

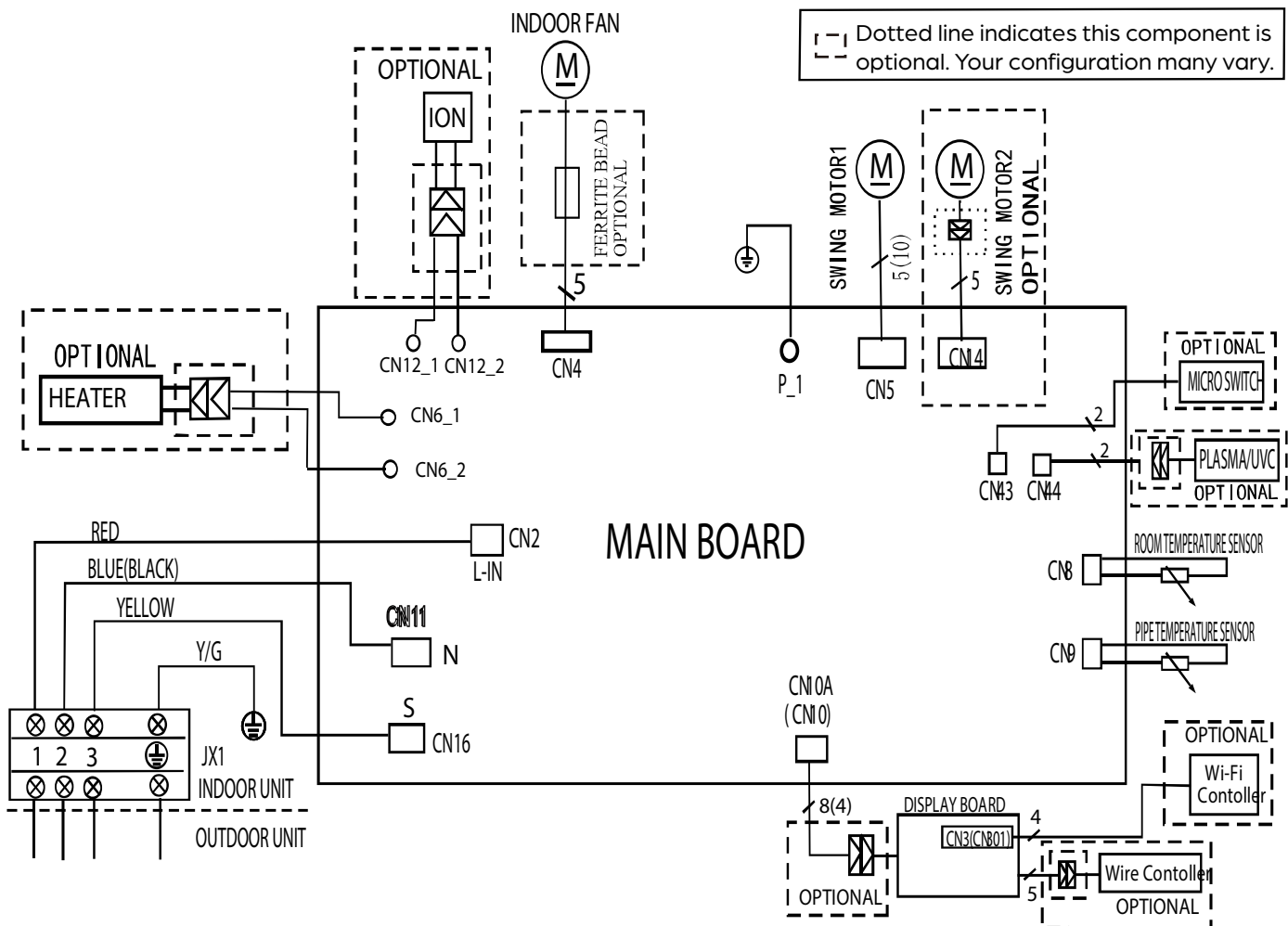

DRAW18F1B and DRAW24F1B

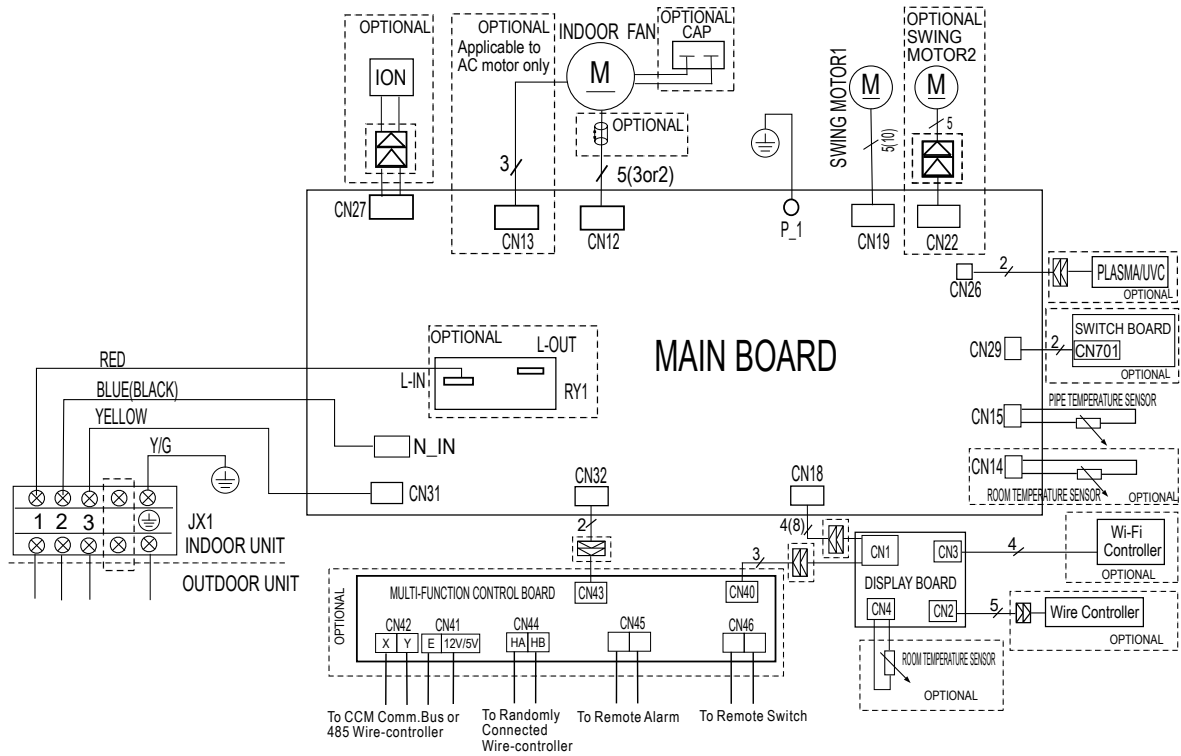

--- Dotted line indicates this component is optional. Your configuration may vary.

DRAW33F1B

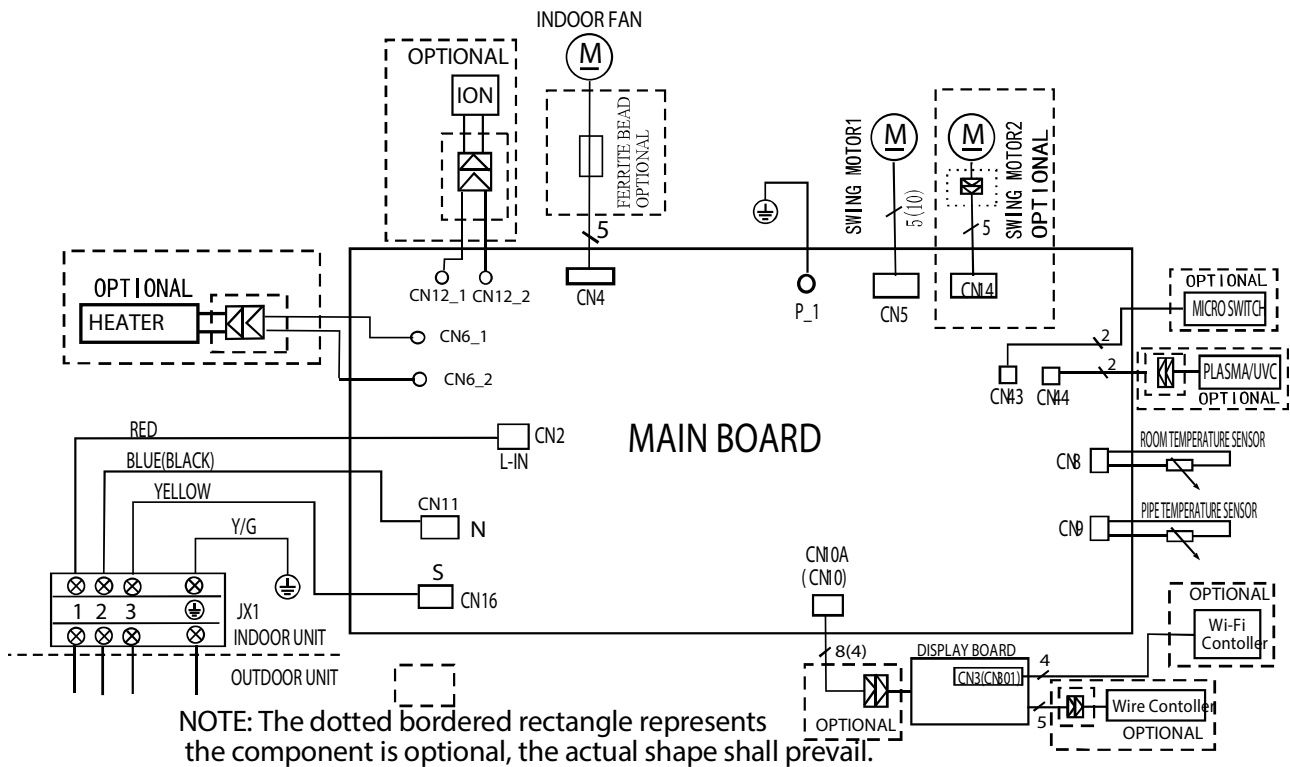

ERROR AND OPERATING CODES

Running Lamp	Timer Lamp	Display	Information
--	--	DF	Defrost *
--	--	SC	Self clean *
--	--	CL	Filter cleaning reminder(power on display for 15 seconds) *
--	--	CL	Active clean(for some units) *
--	--	RF	Filter replacement reminder(power on display for 15 seconds) *
--	--	FP	Freeze protection heating 46°F/54°F (8°C/12°C) *
--	--	FC	Forced cooling *
--	--	AP	AP mode of WIFI connection *
--	--	CP	Remote switched off *
1 time	OFF	EH00/EH0A	Indoor unit EEPROM parameter error
2 times	OFF	EL01	Indoor/outdoor unit communication error
3 times	OFF	EH02	Zero-crossing signal detection error
4 times	OFF	EH03	The indoor fan speed is operating outside of the normal range
5 times	OFF	EC51	Outdoor unit EEPROM parameter error
5 times	OFF	EC52	Condenser coil temperature sensor T3 is in open circuit or has short circuited
5 times	OFF	EC53	Outdoor room temperature sensor T4 is in open circuit or has short circuited
5 times	OFF	EC54	Compressor discharge temperature sensor TP is in open circuit or has short circuited
5 times	OFF	EC56	Evaporator coil outlet temperature sensor T2B is in open circuit or has short circuited(for free-match indoor units)
6 times	OFF	EH60	Indoor room temperature sensor T1 is in open circuit or has short circuited
6 times	OFF	EH61	Evaporator coil middle temperature sensor T2 is in open circuit or has short circuited
12 times	OFF	EC07	The outdoor fan speed is operating outside of the normal range
9 times	OFF	EH06	Indoor PCB/Display board communication error
8 times	OFF	EL0C	Refrigerant leakage detection
7 times	FLASH	PC00	IPM malfunction or IGBT over-strong current protection
2 times	FLASH	PC01	Over voltage or over low voltage protection
3 times	FLASH	PC02	Top temperature protection of compressor or High temperature protection of IPM module or High pressure protection
5 times	FLASH	PC04	Inverter compressor drive error
1 time	FLASH	PC08	Current overload protection
6 times	FLASH	PC40	Communication error between outdoor main chip and compressor driven chip
7 times	FLASH	PC03	Low pressure protection
1 times	ON	--	Indoor units mode conflict(match with multi outdoor unit)

* Normal operating codes, not malfunctions.

THIS PAGE INTENTIONALLY LEFT BLANK.