

**SERVICE MANUAL**

\*\*\*\*\*

**2013**

**UNDERCOUNTER & ALL PURPOSE DISHWASHERS**

---



**UNDERCOUNTER  
DISHWASHER**

Models:      AD – 48 W  
                  AD – 64 CW  
                  AD – 72 W

## Contents

---

SPECIFICATIONS .....	1
AD – 48 W .....	1
AD - 64 CW .....	2
AD – 72 W .....	3
INSTALLATION .....	4
VISUAL INSPECTION .....	4
INSTALLATION DIAGRAMS .....	4
DATA PLATE .....	6
POSITIONING .....	6
WATER INSTALLATION .....	7
REQUESTED QUALITY OF THE WATER .....	8
WATER DRAINAGE INSTALLATION .....	8
ELECTRICAL CONNECTION .....	9
TRANSFORMATION OF PHASES .....	10
INSTALLATION CHECKLIST .....	13
OPERATION .....	14
TURNING THE MACHINE ON .....	14
PREPARING THE MACHINE .....	14
WASHING .....	14
DRAINING AND CLEANING .....	15
DETERGENT CONTROL .....	16
PREPARING THE WARE .....	17
DELIMING .....	17
TROUBLESHOOTING .....	18
ELECTRICAL DIAGRAMS .....	21
WIRING SCHEMATICS .....	23
RECOMMENDED SPARE PARTS .....	25
LIMITED WARRANTY .....	26

## SPECIFICATIONS

---

### AD – 48 W

---

#### PERFORMANCE/CAPACITIES

##### Capacities

Racks per hr.: 30  
Dishes per hr.: 750  
Glasses per hr: 1080  
Tank: 6.6gal. / 24.9 liters

##### Water Consumption / Requirements

Gallons per hr. (Max. use): 27gal. / 102 liters  
Gallons per cycles: .9 gal. / 3 liters  
Inlet temperature: 140°F  
Flow rinse pressure: 20-25 psi

##### Wash Pump Motor

Motor (hp): 1 hp

##### Temperatures

Wash: 150°F / 66°C  
Rinse: 180°F / 82°C

##### Heating Elements

Electric wash tank heater: 2.8 Kw  
Electric booster heater: 2.8 Kw

##### Operating Cycles

Wash time (Seconds): 3 settings (40/70/160)  
Dwell (Seconds): 5  
Rinse time (Seconds): 15  
Total Time (Seconds): 3 settings (60/90/180)

##### Dimensions / Shipping

Width: 24 1/4" / 616 mm  
Depth: 27 1/2" / 698 mm  
Height: 38 1/2" / 978 mm  
Max clearance for dishware: 12 1/2" / 318mm  
Rack: 20" x 20" / 500mm x 500mm  
Shipping weight: 160 lbs. / 73 kg  
Shipping volume (cu. ft.): 15

#### TECHNICAL SPECIFICATIONS

##### Total Power Consumption

Volts	Amps	Power (KW)
208/60/1	14.9	3.1
220/60/1	15.9	3.5
240/60/1	17.0	4.1

##### Boiler Power Consumption

Volts	Amps	Power (KW)
208/60/1	12	2.5
220/60/1	12.7	2.8
240/60/1	13.75	3.3

##### Pump Power Consumption

Volts	Amps	Power (KW)
208/60/1	2.4	0.5
220/60/1	2.7	0.6
240/60/1	2.9	0.7

**PERFORMANCE/CAPACITIES**

**Capacities**

Racks per hr.: 40  
 Dishes / per hr.: 1000  
 Wash Tank: 6.6gal. / 24.9 liters

**Water Consumption**

Gallons per hr. (Max. use): 36 gal. / 139 liters  
 Gallons per cycles: .9 gal. / 3 liters  
 Inlet temperature: 140°F  
 Flow rinse pressure: 20-25 psi

**Wash Pump Motor**

Motor (hp): 1 hp

**Temperatures**

Wash: 150°F / 66°C  
 Rinse: 180°F / 82°C

**Heating Elements**

Electric wash tank heater: 2.8 Kw  
 Electric booster heater: 6 Kw

**Operating Cycles**

Wash time (Seconds): 3 settings (40, 70, 160)  
 Dwell (Seconds): 5  
 Rinse time (Seconds): 15  
 Total Time (Seconds): 3 settings (60, 90, 180)

**Dimensions / Shipping**

Width: 25" / 635 mm  
 Depth: 27 1/2" / 698 mm  
 Height: 38 1/2" / 978 mm  
 Max clearance for dishware: 12 1/2" / 318mm  
 Rack: 20" x 20" / 500mm x 500mm  
 Shipping weight: 160 lbs. / 73 kg  
 Shipping volume (cu. ft.): 15

**TECHNICAL SPECIFICATIONS**

**Total Power Consumption**

Volts	Amps	Power (KW)
208/60/3	16.6	6.0
220/60/3	17.6	6.7
240/60/3	19.0	7.9

**Pump Power Consumption**

Volts	Amps	Power (KW)
208/60/3	1.3	0.5
220/60/3	1.6	0.6
240/60/3	1.7	0.7

**Boiler Power Consumption**

Volts	Amps	Power (KW)
208/60/3	15.0	5.4
220/60/3	15.7	6.0
240/60/3	17.1	7.1

**Total Power Consumption**

Volts	Amps	Power (KW)
208/60/1	28.8	6.0
220/60/1	30.4	6.7
240/60/1	32.9	7.9

**Pump Power Consumption**

Volts	Amps	Power (KW)
208/60/1	2.4	0.5
220/60/1	2.7	0.6
240/60/1	2.9	0.7

**Boiler Power Consumption**

Volts	Amps	Power (KW)
208/60/1	25.9	5.4
220/60/1	27.2	6.0
240/60/1	29.5	7.1

**PERFORMANCE/CAPACITIES**

**Capacities**

Racks per hr.: 40  
 Trays (Dishes) / per hr.: 320 (1000)  
 Wash Tank: 6.6gal. / 24.9 liters

**Water Consumption**

Gallons per hr. (Max. use): 36 gal. / 139 liters  
 Gallons per cycles: .9 gal. / 3 liters  
 Inlet temperature: 140°F  
 Flow rinse pressure: 20-25 psi

**Wash Pump Motor**

Motor (hp): 1 hp

**Temperatures**

Wash: 150°F / 66°C  
 Rinse: 180°F / 82°C

**Heating Elements**

Electric wash tank heater: 2.8 Kw  
 Electric booster heater: 6 Kw

**Operating Cycles**

Wash time (Seconds): 3 settings (40,70,160)  
 Dwell (Seconds): 5  
 Rinse time (Seconds): 15  
 Total Time (Seconds): 3 settings (60,90,180)

**Dimensions / Shipping**

Width: 47 1/3" / 1203 mm  
 Depth: 27 1/2" / 698 mm  
 Height: 38 1/2" / 978 mm  
 Max clearance for dishware: 16 1/2" / 420mm  
 Rack: 20" x 20" / 500mm x 500mm  
 Shipping weight: 174 lbs. / 79 kg  
 Shipping volume (cu. ft.): 29

**TECHNICAL SPECIFICATIONS**

**Total Power Consumption**

Volts	Amps	Power (KW)
208/60/3	16.6	6.0
220/60/3	17.6	6.7
240/60/3	19.0	7.9

**Pump Power Consumption**

Volts	Amps	Power (KW)
208/60/3	1.3	0.5
220/60/3	1.6	0.6
240/60/3	1.7	0.7

**Boiler Power Consumption**

Volts	Amps	Power (KW)
208/60/3	15.0	5.4
220/60/3	15.7	6.0
240/60/3	17.1	7.1

**Total Power Consumption**

Volts	Amps	Power (KW)
208/60/1	28.8	6.0
220/60/1	30.4	6.7
240/60/1	32.9	7.9

**Pump Power Consumption**

Volts	Amps	Power (KW)
208/60/1	2.4	0.5
220/60/1	2.7	0.6
240/60/1	2.9	0.7

**Boiler Power Consumption**

Volts	Amps	Power (KW)
208/60/1	25.9	5.4
220/60/1	27.2	6.0
240/60/1	29.5	7.1

## INSTALLATION

### VISUAL INSPECTION

Before installing the unit, check the package and machine for damage. All machines have been tested, inspected and packed at the factory and is expected to arrive to you in new, undamaged condition. Visually inspect the exterior of the package. Any damage should be noted and reported to the delivering carrier immediately. If damaged, open and inspect the contents with the carrier.

In the event that the exterior is not damaged, yet upon opening there is concealed damage to the equipment, please notify the carrier. Notification should be made verbally as well as in written form. Request an inspection by the shipping company of the damaged equipment. Also, contact the dealer through which you purchased the unit.

### INSTALLATION DIAGRAMS

#### AD-48W

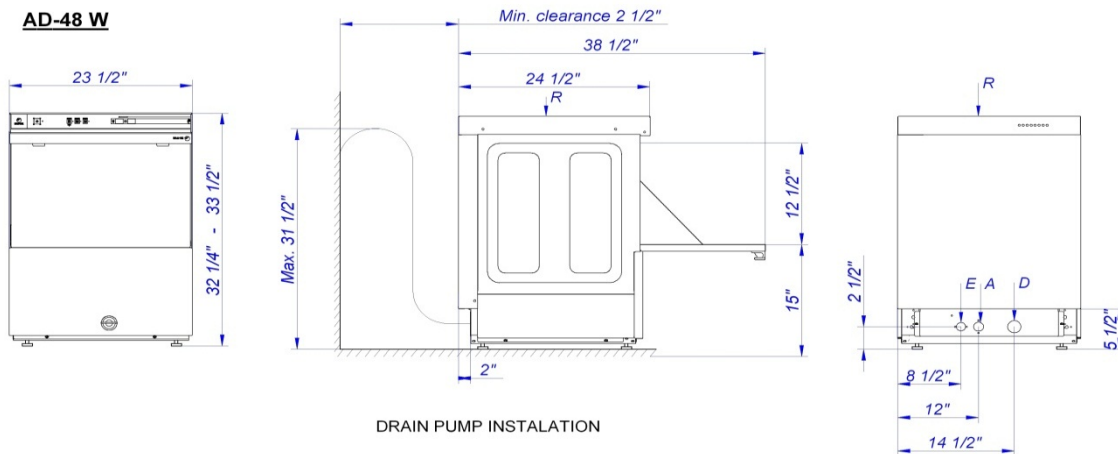

#### AD-64 CW

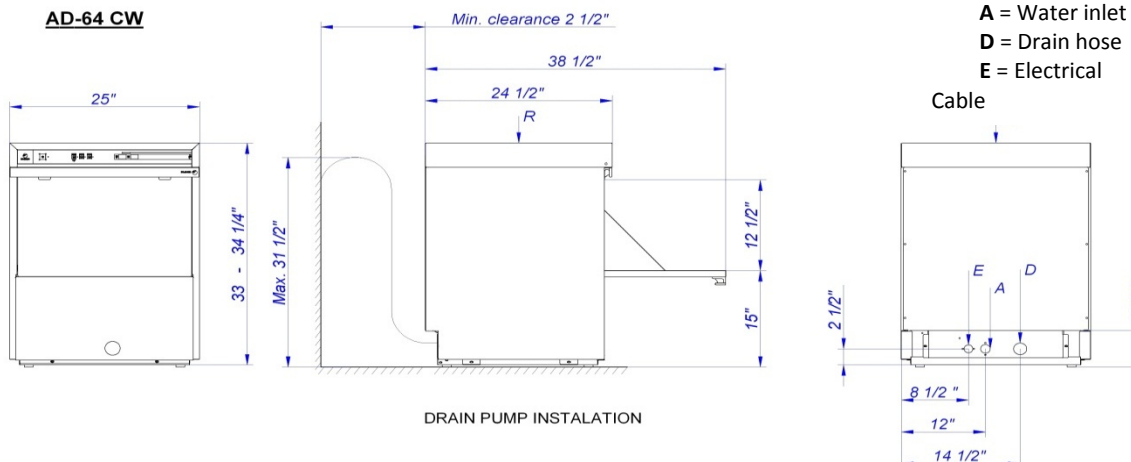

AD-72W

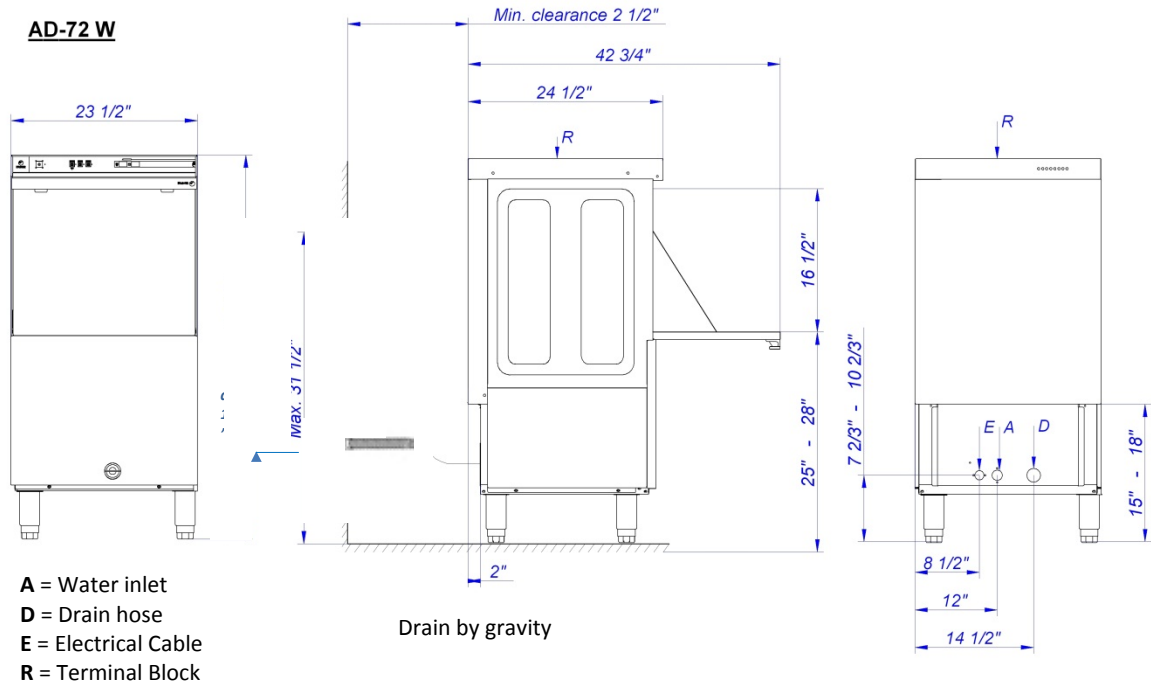

## DATA PLATE

The data plate is located on one side of the machine. Under no circumstances should the data plate be removed from the unit. The data plate is essential to identify the particular features of your machine and is of great benefit to installers, operators and maintenance personnel. It is recommended that, in the event the data plate is removed, you copy down the essential information in this manual for reference before installation.

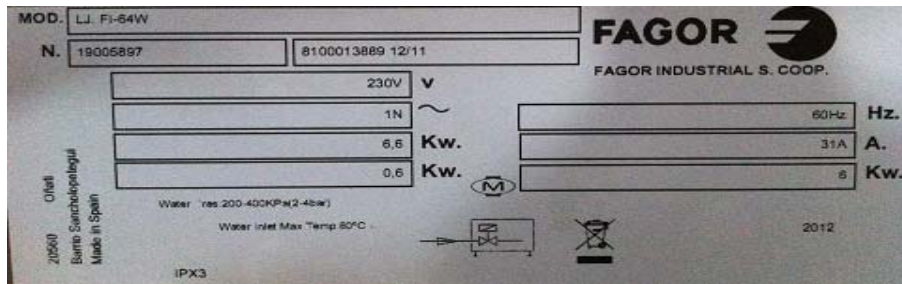

Any transformations or changes made on the machines during installation should be reflected on the data plate or using a label as below:

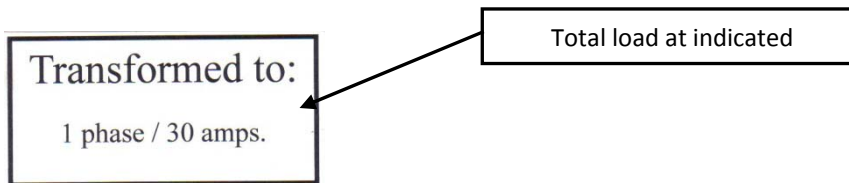

## POSITIONING

Leveling and adjusting the height of the appliance is done by turning the leveling stands to the desired height. Ensure that the unit is level before making any connections (Fig. 2).

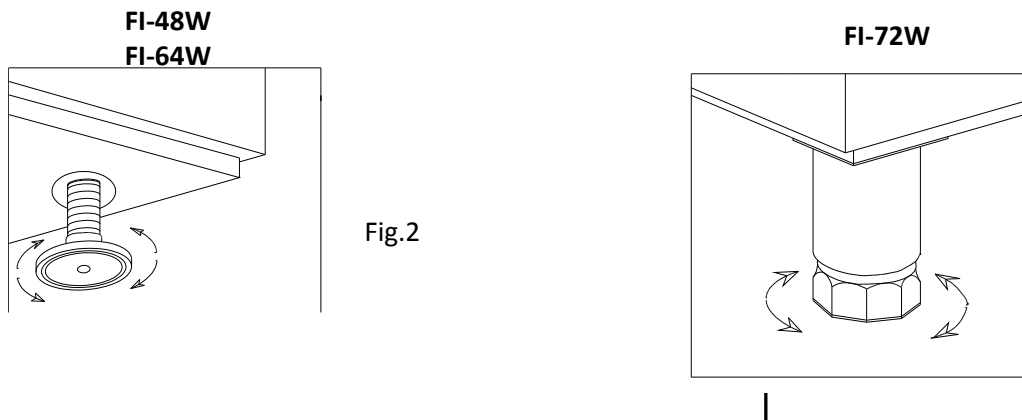



## WATER INSTALLATION

Water installation is carried out as shown in figures 3 and 4. The hot water line to the dishwasher must provide between 25<sup>±5</sup> psi of water pressure. The hot water heater should be set to deliver ≥140°F (not lower than 120°F) water temperature to the dishwasher for best results. Use 3/4" copper tubing inlet line.

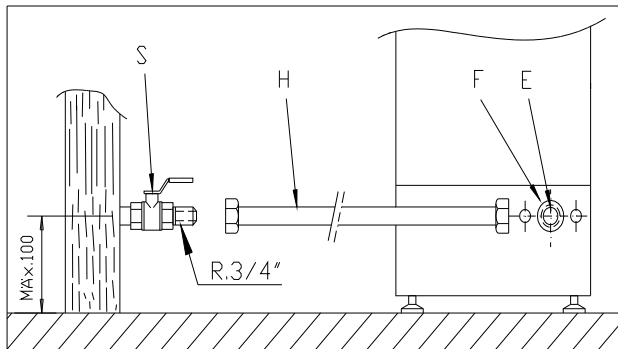

- S = Gate valve
- F = Filter
- H = Hose
- E = Fill valve
- M = Pressure gauge
- R = 3/4" Copper

**CAUTION:** Do not confuse static pressure with flow pressure. Static pressure is the line pressure in a “no flow” condition (all valves and services are closed). Flow pressure is the pressure in the fill line when the solenoid valve is opened during the cycle

THE DISPLAY OF THE PRESSURE GAUGE SHALL BE CLEARLY VISIBLE OF THE OPERATOR OF THE MACHINE. THE GAUGE SHALL HAVE INCREMENTS OF 1 psi (7 kpa) OR SMALLER AND SHALL BE ACCURATE TO ±2 psi (±14 kpa) IN THE 20 psi (103-172 kpa) RANGES. IF THE GAUGE IS LOCATED UPSTREAM OF THE CONTROL VALVE, IT SHALL BE MOUNTED IN AN ACCESSIBLE VALVE WITH A 1/4 IN IRON PIPE SIZE CONNECTION.

If the water pressure is less than 20 psi (1.4 kg/cm<sup>2</sup>), installation of a water pump is required as shown in Fig. 4. In areas where the pressure fluctuates or is greater than the recommended pressure, it is suggested that a water pressure regulator be installed.

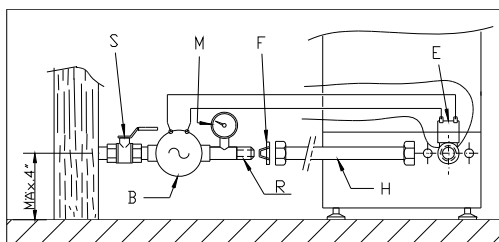

- S = Stop cock
- F = Filter
- H = Hose
- E = Electro valve
- B = Electro pump
- M = Manometer
- R = 3/4" Copper

## REQUESTED QUALITY OF THE WATER

---

- Hardness: 5-10° F
- Conductivity 200-2000 µS
- pH 6.5 – 7.5
- Chloride's concentration < 150 m g/litre
- Chlorine 0.2-0.5 mg/litre
- Impurities < 0,08 mm

It is necessary to remove all foreign debris from the water line that may potentially get trapped in the valves or cause an obstruction, prior to connecting to the machine.

Use only the supplied hoses (3/4" Female hose connector) at the water connections. Failure to do so may result in damage to the solenoid valve threads and leaking. Tighten by hand. Connect the bent side of the hose to the machine. Adaptor supplied for 3/4" female garden hose connection.

FOR HARD WATER SUPPLIES WITH A HARDNESS OF OVER 2 GRAINS OR 10°F AND PH BEYOND THE RANGE OF 7.0 – 8.5, A WATER CONDITIONER MUST BE INSTALLED.

Slowly turn on the water supply to the machine after the incoming fill line and the drain line have been installed. Check for any leaks and repair as required. All leaks must be repaired prior to placing the machine in operation.

## WATER DRAINAGE INSTALLATION

---

Attach the drain hose as shown in Fig. 5. It is recommended to affix a siphon pipe to prevent odors. All piping from the machine to the drain must be a minimum 1-1/2" I.P.S. There should also be an air gap between the machine drain line and the drain. For natural overflow efficiency use floor drain.

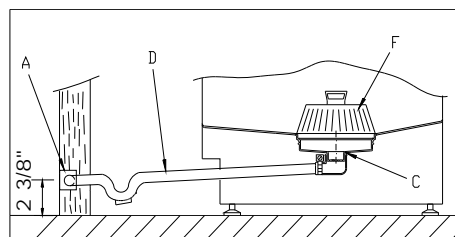
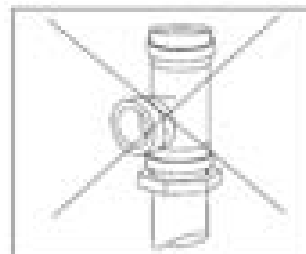

Fig. 5

- D = Drain hose
- C = Drain collector
- A = Air Gap
- F = Scrap Basket



## ELECTRICAL CONNECTION

To access to the electrical terminal block (R) (Fig. 6), remove the top cover (T) and the rear panel (P) (Fig.7). Connect the wires as shown in figure 8. Insert the power cord through the cord strain relief (E) (Fig. 4) and make sure to leave enough cable to remove the electrical panel from the front for service. Tighten the connections.

Leave at least 39 in. (≥ 1000 mm) of electrical power cord slack from back panel of the unit to the wall to facilitate cleaning behind the dishwasher.

Install a circuit breaker in accordance to required consumption guidelines and data plate.

The machine must be grounded.

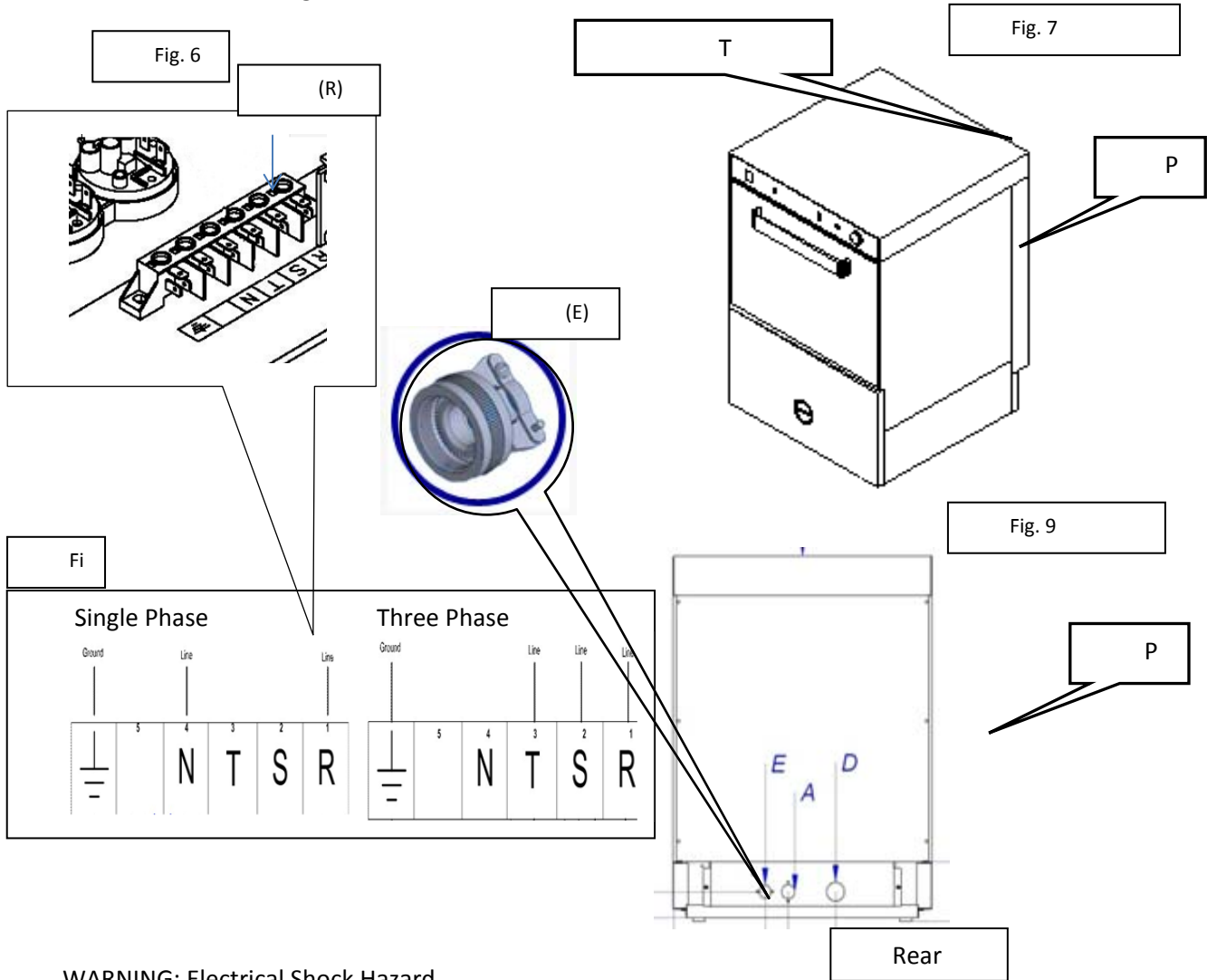

**WARNING: Electrical Shock Hazard**

It is the personal responsibility and obligation of the customer to contact a qualified electrician to assure that the electrical installation is adequate and is in conformance with the National Electrical Code, ANSI / NFPA 70 – latest edition and all local codes and ordinance.

**TRANSFORMATION OF PHASES**

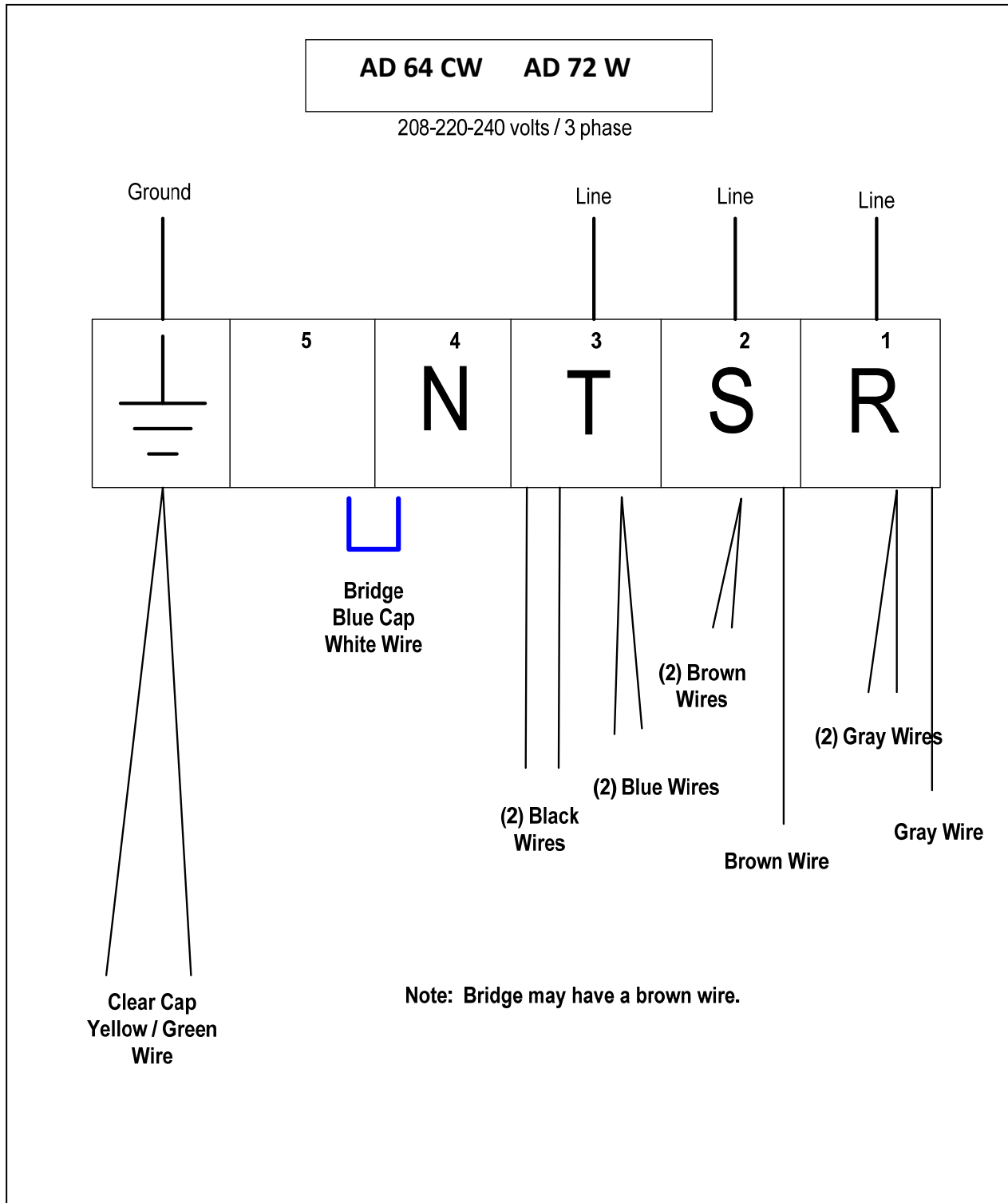

**AD 64 CW AD 72 W**

208-220 volts / 1 phase

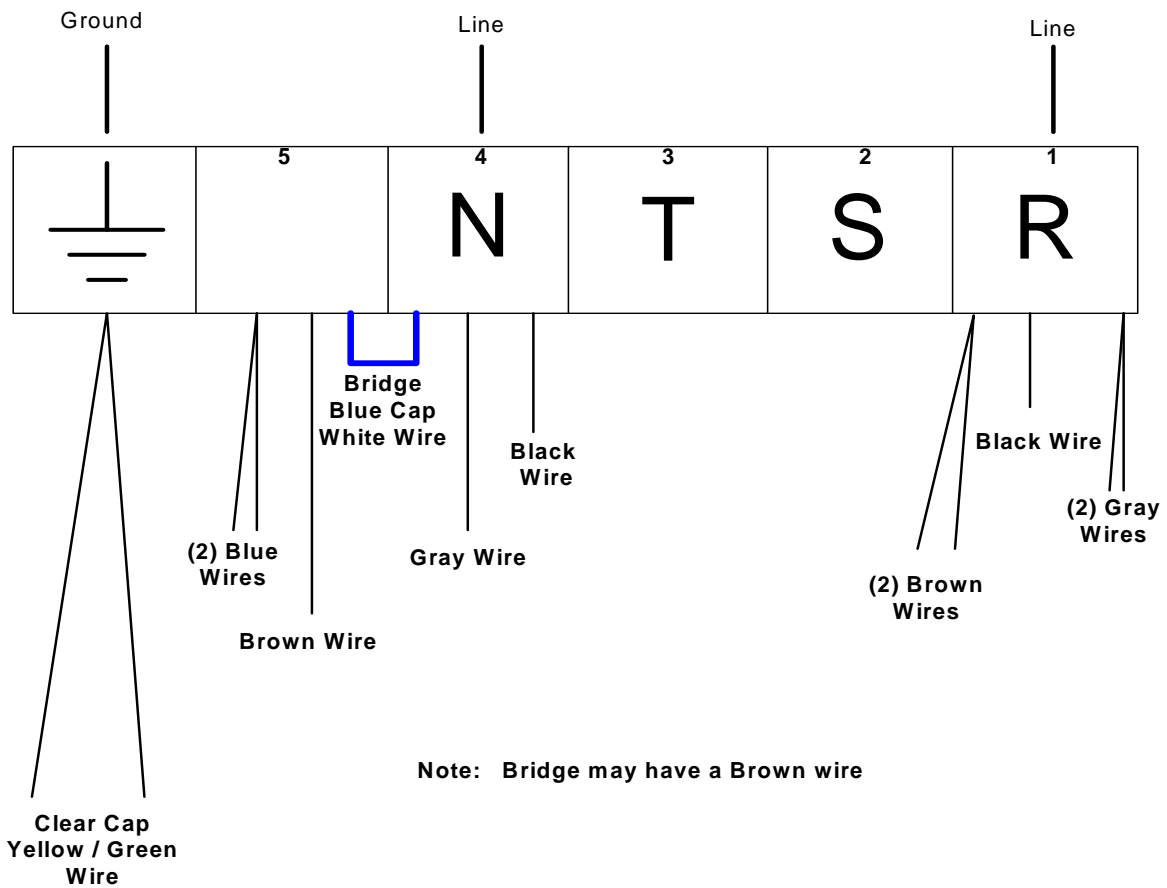

**AD 64 CW AD 72 W**

208-220 volts / 1 phase

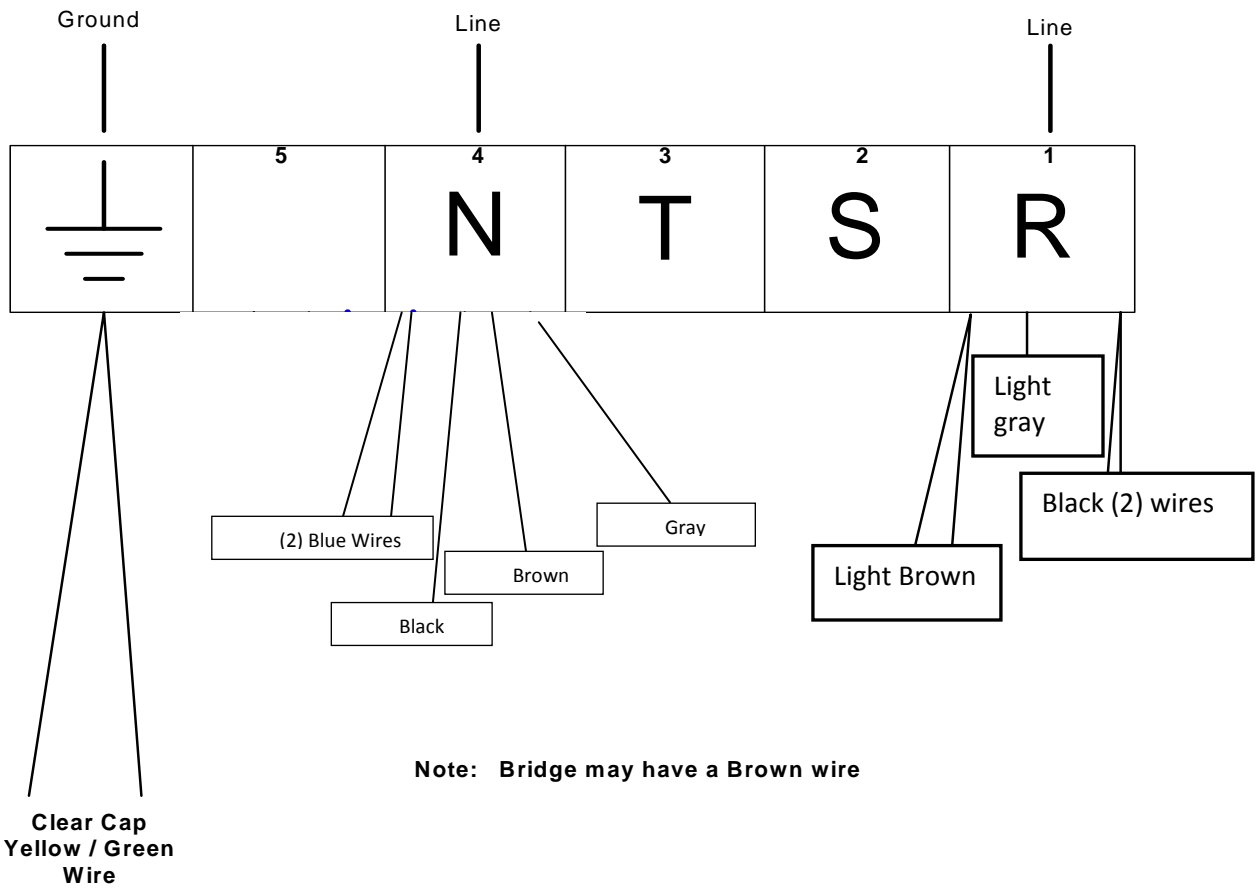

## INSTALLATION CHECKLIST

• **CHECK OFF THE FOLLOWING ITEMS AS THEY ARE COMPLETED BEFORE PROCEEDING TO OPERATE OR SERVICE THE DISHWASHER.**

- Has the dishwasher been properly leveled?
- Has the service voltage been checked to ensure that it meets the requirements listed on the dishwasher specifications (Page 2)?
- Circuit Breaker size \_\_\_\_\_ Voltage \_\_\_\_\_ Phase \_\_\_\_\_ Existing or New electrical install \_\_\_\_\_
- Has the dishwasher been properly grounded?
- Are the electrical connections and plumbing pipes tightening to proper torque levels?
- Has been installed with the supplied water hose? If not, Specify specs of the water hose install  
Thread \_\_\_\_\_ Size \_\_\_\_\_ Brand \_\_\_\_\_
- Flush water supply line before opening water valve
- Is the water valve open?
- Is the incoming water supply at 20 - 25 psi?
- Verify water hose, drain hose and chemical hoses are not kinked?
- Is the hot water supply at the optimum temperature (140°F)? If not, list water temperature \_\_\_\_\_ °F
- Is the water hardness  $\leq 2.0$ gpg/34.2ppm and PH level 7 - 8.5ph?
- Has the drain plumbing been installed according to the instructions in this manual?
- Height of the drain hose \_\_\_\_\_ Air gap size \_\_\_\_\_
- Was the drain installed to a garbage disposal? If yes, has been installed a back flow safety in case the garbage disposal fail?  
\_\_\_\_\_ ***Damages to a drain pump due to a failure of a garbage disposal will not be covered under warranty***
- Is the overflow tube with the O-ring fitted in its position inside the tank
- Is the detergent for commercial dishwashers?
- Have you adjusted the amount of detergent / rinse going to the machine? \_\_\_\_\_ Adjustments ***on detergent/rinse pump are not cover under warranty. Please refer to page 18 for instructions.***

**In order to validate your warranty this checklist must be return to Fagor along with the product registration card.**

MODEL NO. \_\_\_\_\_  
SERIAL NO. \_\_\_\_\_  
INSTALLATION DATE \_\_\_\_\_  
SERVICE REP. NAME \_\_\_\_\_  
PHONE N° \_\_\_\_\_

Registration can be completed by mail, phone, and fax or on the website [www.fagorcommercial.com](http://www.fagorcommercial.com)  
Fax: 3057790173  
13105 NW 47 Ave. Opa Locka, FL 33054  
[servicerequest@fagorcommercial.com](mailto:servicerequest@fagorcommercial.com)

## OPERATION

---

### AD-48W / AD-64 CW / AD-72 W

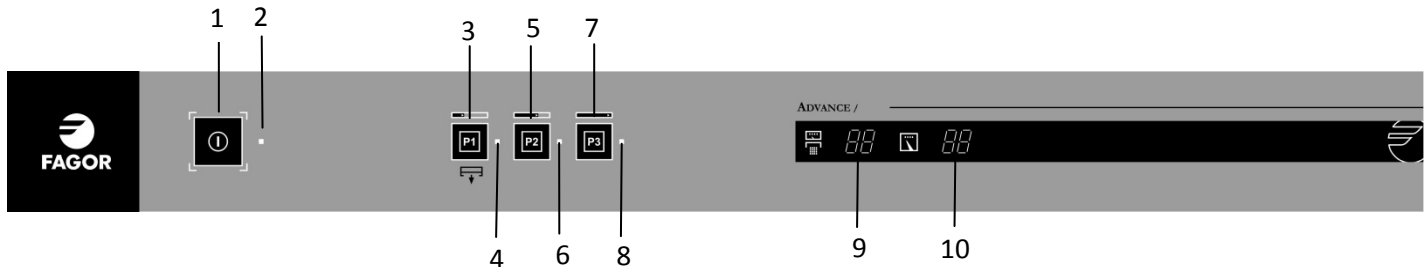

Fig. 7

## TURNING THE MACHINE ON

---

Press and hold the power button (1) for five seconds. LED # 2 will lit up and the machine will start filling up with water.

## PREPARING THE MACHINE

---

After the machine has filled it will start heating up the rinse tank and the wash tank. The machine is ready to wash when the thermometer (9) indicates 180° F (83°C) and the thermometer (10) 160° F (71°C). It is the user's responsibility to wait until the minimum temperatures are displayed before putting the machine to wash.

## WASHING

---

**NOTE:** All models are fitted with Thermo-stop. The temperature of the incoming water should be higher than 120°F/50 °C. (Ideal temp. 140°F/60 °C) If it is lower, the machine's capacity may be affected and you may have extended cycles.

There are 3 washing cycles for models described before: P1 (3), P2 (5) and P3 (7) of 60, 90 and 180 seconds respectively. (Fig.7). LED's numbers 4, 6 and 8 indicate that the machine is working; depending on selected programme, one or other led will switch on.

***If you start your dishwasher prior to your booster heater (9) reaching a minimum of 180° F (83°C), YOU WILL HAVE AN EXTENDED WASH CYCLE!***



## DRAINING AND CLEANING

Draining must occur EVERY DAY and if in a high application; it should be drained after each meal rush!

### AD-48W / AD-64 CW / AD-72 W

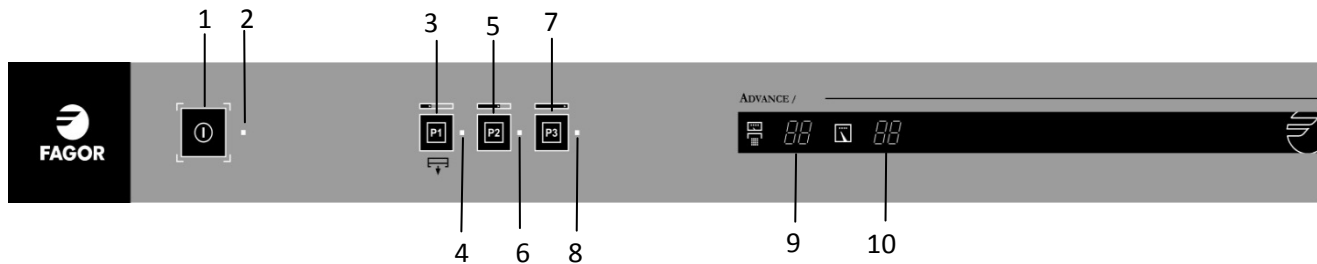
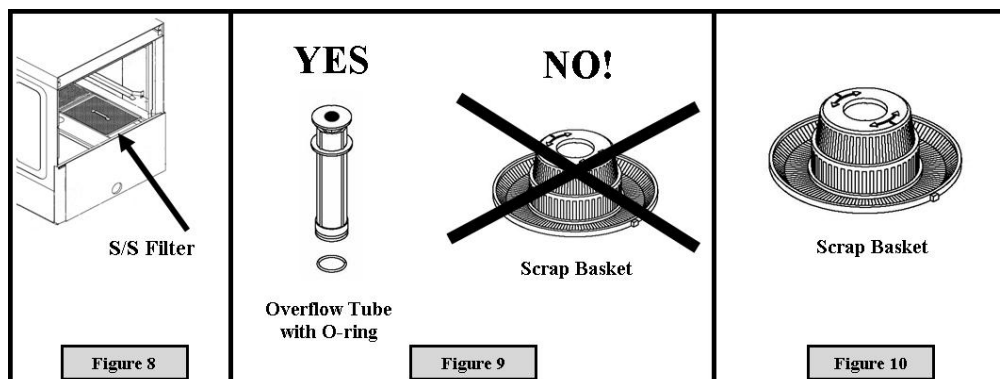

Fig. 7

#### Draining the Machine

- Open the door and remove the Front Right S/S Filter, leave door open. (Fig. 8)
- Remove the overflow tube by inserting a finger into the top of the tube. (Fig. 9)  
*DO NOT REMOVE SCRAP BASKET! DO NOT LOOSE O’RING FROM OVERFLOW TUBE!*
- Press and hold the button P1 (3) for 5 seconds (Fig. 9). The led number 4 will illuminate during operation
- Wait until the led (3) turns off. (3 minutes 20 seconds)
- Take out scrap basket for cleaning by twisting to the left. (Fig. 10)
- Replace scrap basket, lock into position by twisting to the right and replace overflow tube with O-ring.
- Replace S/S filter back into position. (Fig. 8)
- Press power switch (1) to turn unit OFF

To avoid the risk of damage from oxidization or corrosion from chemicals, keep all steel surfaces clean and dry. It is advisable to change the tank water, by new filling, at least every 40-50 washes or twice a day.



## DETERGENT CONTROL

Use ONLY Commercial Grade, High Temperature, Low Suds Liquid Detergent. Fagor doesn't recommend any specific brand name of chemicals. Contact your local chemical distributor for questions concerning your chemical needs.

All machines come equipped with an internal Detergent and Rinse dispenser.

Take the tube located in the back of your machine marked "Detergent" and place inside detergent container.

Take the tube with a blue stripe mark and place inside rinse container.

Tubes are clear to provide you a visible means that chemicals are being dispensed.

If desired you can control the amount of Chemical being dispensed by opening the bottom front panel of the machine. Locate the detergent dispenser (Fig. 9) and regulate according to the flow chart (Fig. 9a). For the Rinse, turn the button counterclockwise to get more rinse aide and clockwise for less. Verify all connections to the dispenser are hand tighten to prevent any leaks.

Control and maintain the level of detergent and rinse aid of the tanks. Keep chemical tubing and filters submerged.

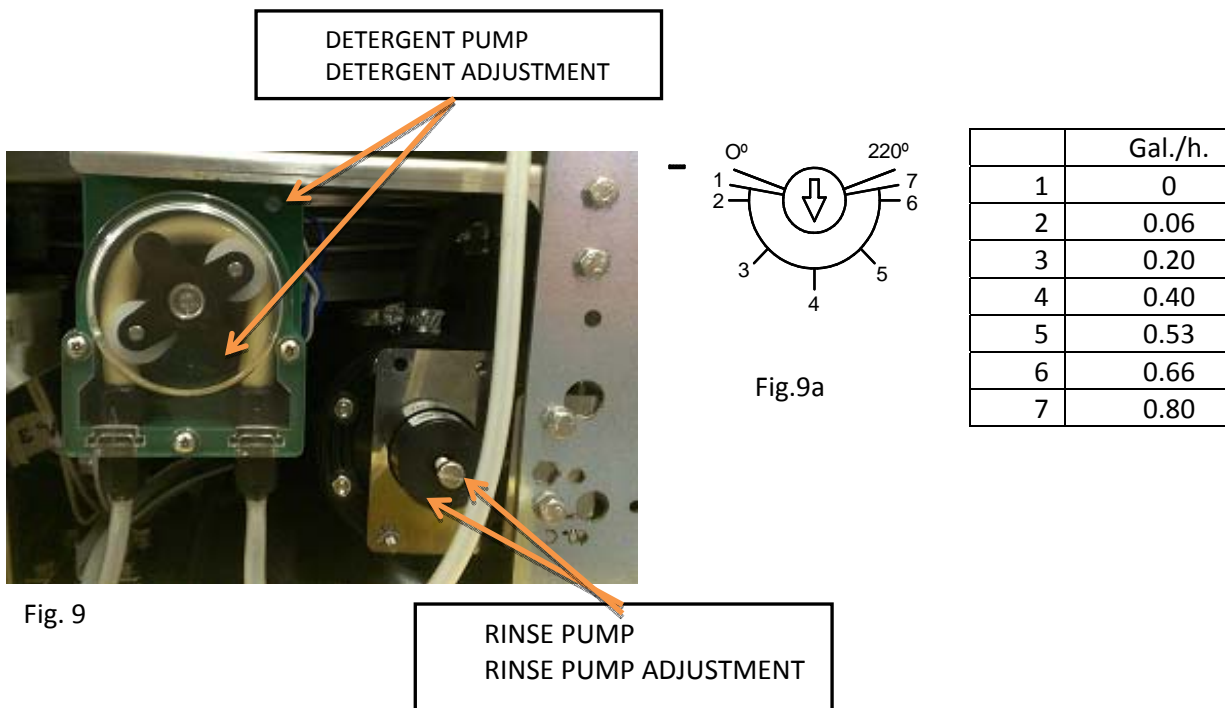

Fig. 9

Fig.9a

### Warning!

If you require the installation of a NON FAGOR Detergent and Rinse pump, a form MUST be fill out prior to installation by your installer. Failure to do so will void your Warranty. This form can be located inside your dishwasher. If lost, please contact Fagor to get a copy.

Note: The detergent pump and rinse dispensing pump will only work during the process of fill and rinse.

## PREPARING THE WARE

---

- Pre-scrap and rinse all racks prior to placing them in the dishwasher to remove large food particles (pre- scrap) from the ware.
- Wash glassware first
- Put trays in the baskets, making sure is in its separate rack (Fig.12).
- Put plates in the baskets, making sure each is in its separate rack (Fig. 11).
- Put glasses in upside down.
- Put cutlery in the cutlery baskets handles down. Mix spoons with knives and forks. (Fig. 10)
- Put the special cutlery baskets in the base baskets.

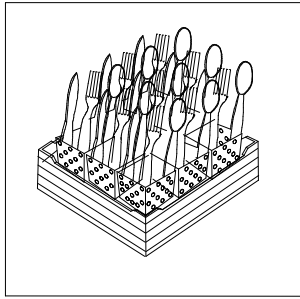

Fig. 10

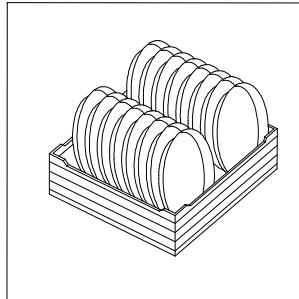

Fig. 11

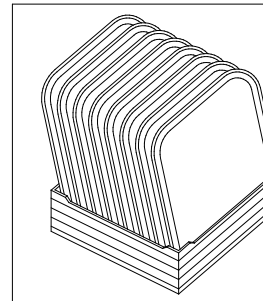

Fig.12

## DELIMING

---

In order to maintain dishwasher at optimum conditions, it is requested to remove lime and corrosion deposits on a frequent basis. A de-liming solution should be available from your chemical supplier. Read and follow all instructions on the label of the de-liming solution. Operations:

Fill the machine. Add the correct amount of de-liming solutions as recommended by the de-liming solution manufacturer. The water capacity of the tank can be verified on the specification sheet of this manual  
Remove detergent and rinsing tubes from containers so no chemicals go to the machine  
Run the machine for the recommended period of time. As many cycles as needed. Turn off the machine and open the door. When clean, drain and re-fill the machine and Run machine for 3-4 cycles to remove de-liming solution  
Drain the machine.

## TROUBLESHOOTING

SYMPTOM	POSSIBLE CAUSE	ACTION
Dishwasher will NOT FILL after the door is closed. Power "ON" light (L1) is not illuminated.	Service breaker tripped	Reset. If the breaker trips again, contact an electrician to verify amps or possible short.
	Machine not connected to power source.	Verify the unit is connected to a hot (live) feed. Verify voltage and proper phasing.
	Faulty Circuit Board	Make sure power is being supplied to the board. Check for loose wiring harness connections. Check circuit board fuse. Check voltage between R (brown) and N (blue). If 208V-240V found, replace circuit board.
Dishwasher will NOT FILL or reach the appropriate water level after the door is closed. Power "ON" light (L1) is illuminated.	No water to machine	Verify hose is not blocked or kinked, water valve is open and pressure > 20 psi.
	Machine not level	Level machine. Legs are height adjustable.
	Overflow tube not attached or broken / missing O-ring.	Check condition of overflow tube. Make sure O-ring is in good working condition and in place.
	Faulty door switch	Verify the wiring at the switch for loose connections; if no loose connections are present, replace the switch (Ip) or the door relay (Cp)
	Faulty fill pressure switch (P1)	Verify voltage at terminal 2 (brown) and GND. If no voltage, P1 is possible stuck.
	Faulty rinse/fill valve (V)	Verify the wiring and proper voltage at valve; if correct replace fill valve.
Dishwasher will NOT RUN after the door is closed. Power "ON" light (L1) is illuminated and the unit has completed the filling and heating cycle.	Faulty fill pressure switch (P1)	Verify it changes position of the switch; on terminal 1 to 2 (fill), and 1 to 3 (heating) If not replace it.
	Faulty Power/Start button (St)	Verify good connection between digital start buttons and circuit board. If disconnected, reconnect and verify. Verify circuit board fuse is If connected and still not working, replace Adhesive Trim.
	Faulty Circuit board	Make sure power is being supplied to the board. Check for loose wiring harness connections. Check circuit board fuse. Check voltage between R (brown) and N (blue). If 208V-240V found, replace circuit board.
	Faulty wash pump (MBL)	Rotate the pump from the shaft flat head slot counter-clock wise to verify free rotation. Verify that the wash pump is getting power. If so, replace the pump.
	Faulty start buttons	Verify good connection between digital start buttons and circuit board. If disconnected, reconnect and verify. Verify circuit board fuse is If connected and still not working, replace Adhesive Trim.
	Rinsing temperature gauge is lower than 180°F.	Wait until sanitized rinsing temperature reached a min. of 180°F. Check out your incoming water temperature. Recommended incoming water temperature is 140°F

SYMPTOM	POSSIBLE CAUSE	ACTION
Dishwasher RUNS continuously in the wash cycle or not rinsing.	Faulty Circuit Board	Make sure power is being supplied to the board. Check for loose wiring harness connections. Check circuit board fuse. Check voltage between R (brown) and N (blue). If 208V-240V found, replace circuit board.

Dishwasher RUNS continuously in the wash cycle or not rinsing.	Faulty Circuit Board	Make sure power is being supplied to the board. Check for loose wiring harness connections. Check circuit board fuse. Check voltage between R (brown) and N (blue). If 208V-240V found, replace circuit board.
	Faulty Operating t-stat (Tc)/Faulty Circuit Board	Verify rinse gauge temperature is above 180°F. If above, replace circuit board. If rinse temperature < 180°F replace Tc thermostat and/or boiler element and heater relay. If A4 is displayed, reconnect temperature sensor. If A5 is displayed, replace temperature sensor.
	Faulty rinse/fill valve (V)	Verify the wiring and correct voltage at valve; if correct replace fill valve.
	No water to machine.	Verify hose is not blocked or kinked. Verify the inlet water pressure is at a min of 20 psi and max 25 psi.
	Clogged or obstructed rinse arms	Remove and clean rinse arms/nozzles.
Dishwasher FILLS slowly and/or rinse is weak.	Poor water pressure	Verify the inlet water pressure is at a min of 20 psi and max 25 psi.
	Hose strainer is clogged	Check strainer or any filters installed.
	Bad rinse/ fill valve (V) Valve can be clogged causing poor flow.	Disconnect hose from fill valve and check filter screen inside for debris. Replace rinse/fill valve as needed.
	Temperature gauge in front panel is defective.	Check temperature with a calibrated thermometer at the corresponding temperature sensor location. Replace temperature gauge as needed.
Dishwasher RUNS. RINSE WATER NOT REACHING MINIMUM TEMPERATURE OF 180°F	Misadjusted/faulty thermostat (Tc)	Verify rinse temperature probe sensor is properly inserted inside probe well. Replace Tc thermostat and/or boiler element and heater relay. If A4 is displayed, reconnect temperature sensor. If A5 is displayed, replace temperature sensor.
	Faulty high limit stat (TI)	Reset thermostat by depressing red button. Replace if necessary. Make sure heater relay (Cc) is working properly (not stuck in or out) and Tc thermostat is cutting off below 195°F
	Faulty heater relay (Cc)	Verify voltage at heater relay coil (A1, A2), solenoid closes when receiving voltage. If not, replace heater relay (Cc).
	Faulty Boiler element (Rc)	Ohm out element check for continuity; if open, replace heater (Rc).

SYMPTOM	POSSIBLE CAUSE	ACTION
Dishwasher RUNS. WASH WATER NOT REACHING REQUIRED TEMPERATURE OF 150°F	Low incoming water temperature supplied to the Dishwasher	Check out that incoming water temperature is at least 120°F and pressure is at least 20 psi. Optimal incoming water temperature is 140°F and optimal incoming water pressure is 25 psi.
	Faulty thermostat (Tc)	Verify that there is power on violet (vi) coming from Tc to Tt (only applies after Tc has been satisfied or > 180°F). If <b>A4</b> is displayed, reconnect temperature sensor. If <b>A5</b> is displayed, replace temperature sensor.
	Misadjusted/faulty thermostat (Tt)	Verify voltage to t-stat. If voltage has been verified ok, check tank heater relay Ct
	Tank heater relay (Ct) faulty.	Verify voltage at heater relay coil (A1, A2), solenoid closes when receiving voltage. If not, replace heater relay (Ct)
	Tank heater (Rt) faulty	Ohm out (between 10-12 Ohms) element check for continuity; if open, replace heater (Rt).
Dishwasher Washes and Rinses but Does NOT DRAIN or overflows.	Door is closed	Open the door and push the drain button  for 3 sec.
	Overflow tube not removed.	Open the door and remove the Front Right S/S Filter and remove the overflow tube by inserting a finger through the hole on top of the overflow tube and pull upward.
	Drain pump (BD) clogged.	Open drain pump cover and remove debris. (Lower front panel; unscrew white removable cover, rotate counter-clock wise
	Drain hose kinked	Make sure the drain hose is not kinked and flush out any debris that may have been accumulated.
	Faulty Drain pump (BD)	Verify voltage to drain pump; if receiving voltage, replace Drain pump (BD).
	Faulty safety pressure switch (P2), Overflow.	Verify that the black rubber pressure tube is not kinked or damaged (air leak). If so, replace black rubber pressure tube. If not kinked or damaged, replace pressure switch P2.
	Machine temperatures or pressure may not be to specification.	Wait until sanitized rinsing temperature reached a min. of 180°F. Check out your incoming water temperature. Recommended incoming water temperature is 140°F and incoming water pressure is 20-25 psi.
	None or too little detergent being used.	Make sure detergent to dish ratio is followed to manufacturer specification. Make sure that the detergent and rinse pumps have been adjusted and primed (priming only applies to the rinse pump). Check for kinks along the chemical lines. Make sure that the chemical line brass filters are completely submerged below the chemical level.
Dishes are not coming out clean enough.	Improper loading or overloading	Read chapter on proper loading of dishwasher. Refer to page 15 of this manual.
	Washing and or rinsing arms jammed or dirty.	Check that arms rotate properly by spinning them manually and that rinsing and washing nozzles are not blocked or dirty. Clean if necessary
	Clogged drain	Remove obstruction from the pump and/or make sure the drain hose is not kinked and flush out any debris that may have been accumulated.
	Machine not level	Level machine by adjusting the unit's legs accordingly. Refer to page 6 of this manual
WATER OVERFLOW FROM BOTTOM OF THE DOOR	Excessive inlet pressure	Install pressure reducing valve. Ensure flow is 20-25 psi.
	EXCESS FOAM coming out of the door.	Use ONLY commercial grade, low suds, liquid detergent for commercial appliances. Adjust the amount of chemicals being dispensed to the unit. Refer to page 14 of this manual.
	Low water pressure, rinse aid container is empty, air in the pump and/or lines.	Verify that the min. incoming water pressure is 20 psi. Verify that there is enough rinse aid left in the container. Make sure that the rinse agent chemical lines are primed and free of kinks.
Rinse agent not being dispensed	Detergent tubes not placed properly inside container/improper adjustment	Verify detergent tubes are secured inside container Adjust chemicals to proper levels

# ELECTRICAL DIAGRAMS

AD-48 W.

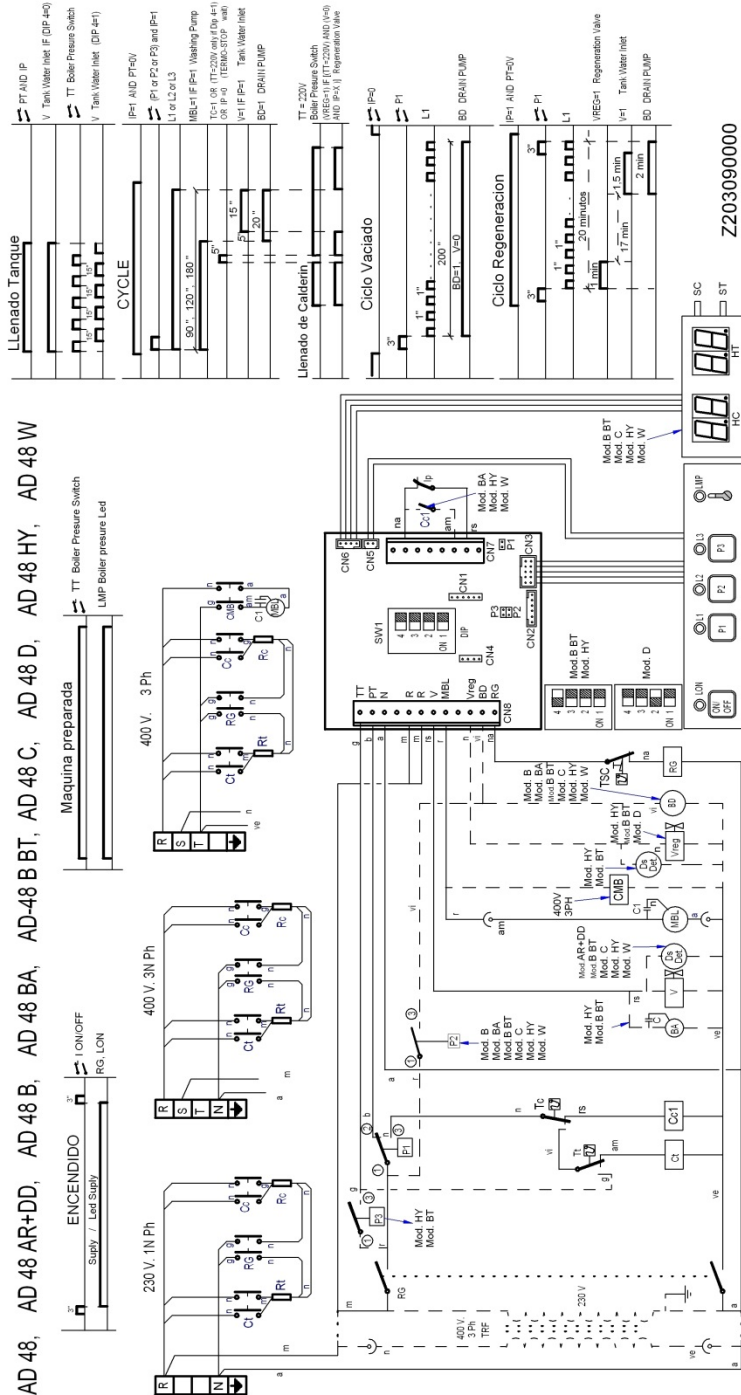

FAGOR ELECTRONICO MODELO ADVANCE	DIP1	DIP2	DIP3	DIP4	TIEMPOS CICLOS (sg.)
AD-48, AD-48 B, AD-48 DD, AD-48 C, AD-64, AD-64 B, AD-64 DD, AD-64 C, AD-72.	OFF	OFF	ON	OFF	P1=60 / P2= 90 / P3=180
AD-48 D, AD-64 D	OFF	ON	ON	OFF	
AD-48 B BT, AD-48 HY, AD-64 B BT, AD-64 HY	OFF	OFF	ON	ON	

DIP1 = ON, al cerrar la puerta o bajar capó el lavavajillas se pone en marcha.  
 DIP1= OFF, al cerrar la puerta o bajar el capó el lavavajillas sigue lavando SÓLO SI EL CICLO NO HA ACABADO.

DIP2 = ON, Para los modelos que llevan DESCALCIFICADOR, versiones "D".  
 DIP2 = OFF, para los modelos con BOMBA DESAGÜE, versiones "B".

DIP1 + DIP3 , con las diferentes combinaciones posibles configuramos los tiempos de ciclo.

DIP4 = ON, Para los modelos "HY".  
 DIP4 = OFF, Para resto de modelos.

-	Esquema teorico	L.A.F., AD 48	-
Zk./INP	Pieza		Material
Zk./INP	Aldaketa/Modificaciones		Nork proposa

AD-72, AD-72 W, AD-64, AD-64 AR+DD, AD-64 B, AD-64 BA, AD-64 B BT, AD-64 C, AD-64 D, AD-64 HY, AD-64 W

ZZ243052000

**FAGOR ELECTRONICO MODELO ADVANCE**

	DIP1	DIP2	DIP3	DIP4
AD-48, AD-48 B, AD-48 DD, AD-48 C, AD-64, AD-64 B, AD-64 DD, AD-64 C, AD-72, AD-48 D, AD-64 D	OFF	OFF	ON	OFF
AD-48 B BT, AD-48 HY, AD-64 B BT, AD-64 HY	OFF	ON	ON	OFF

**TIEMPOS CICLOS (sg.)**

	P1	P2	P3	P4
AD-48, AD-48 B, AD-48 DD, AD-48 C, AD-64, AD-64 B, AD-64 DD, AD-64 C, AD-72, AD-48 D, AD-64 D	60	90	90	180

DIP1 = ON, al cerrar la puerta o bajar capó el lavavajillas se pone en marcha.  
 DIP1 = OFF, al cerrar la puerta o bajar el capó el lavavajillas sigue lavando SÓLO SI EL CICLO NO HA ACABADO.  
 DIP2 = ON, Para los modelos que llevan DESCALCIFICADOR, versiones "D".  
 DIP2 = OFF, para los modelos con BOMBA DESAGUE, versiones "B".  
 DIP1 + DIP3, con las diferentes combinaciones posibles configuramos los tiempos de ciclo.  
 DIP4 = ON, Para los modelos versiones "HY".  
 DIP4 = OFF, Para resto de modelos

Esquema teorico	L.A.F. AD 64	Pieza	Material	Klas. zk/Nº Clas	Gama/akabera Tratamiento
-	-	-	-	-	-
Zk/Nº	Adaketa Modificaciones	Work. proposatua/Propuesta de	Material	Data/Fecha	Perdi orotoraak
-	-	-	-	-	Tolerancias generales
-	-	-	-	-	< 5 ± 0.2
-	-	-	-	-	50 ± 100 ± 0.3
-	-	-	-	-	> 100 ± 1
-	-	-	-	-	5 ± 25 ± 0.4
-	-	-	-	-	25 ± 50 ± 0.3
-	-	-	-	-	α ± 1
Sinadura/Firma	Materia/Firma		Gama/akabera Tratamiento		
Marratza/Dibujado	M.Mallo	30-05-2009	Mecanizado superficial		
Proiektaria/Proyectado	M.Mallo	30-05-2009	-		
Egiazatza/Comprobado	Z. J. J. J.	30-05-2009	Plano Zk./Plano Nº		
Esкала/Escala	-		HC-18216		
<b>FAGOR</b>					
Fagor Industrial/ Koop Etk. Mugatua					
<b>LAVAVAJILLAS A.F.</b>					
Plano hau ezin daterle erabili, ez bertiztatu, gure baimenik gabe.					
Zk. ord. du					
Zk. gatik ord.					



AD-48 W

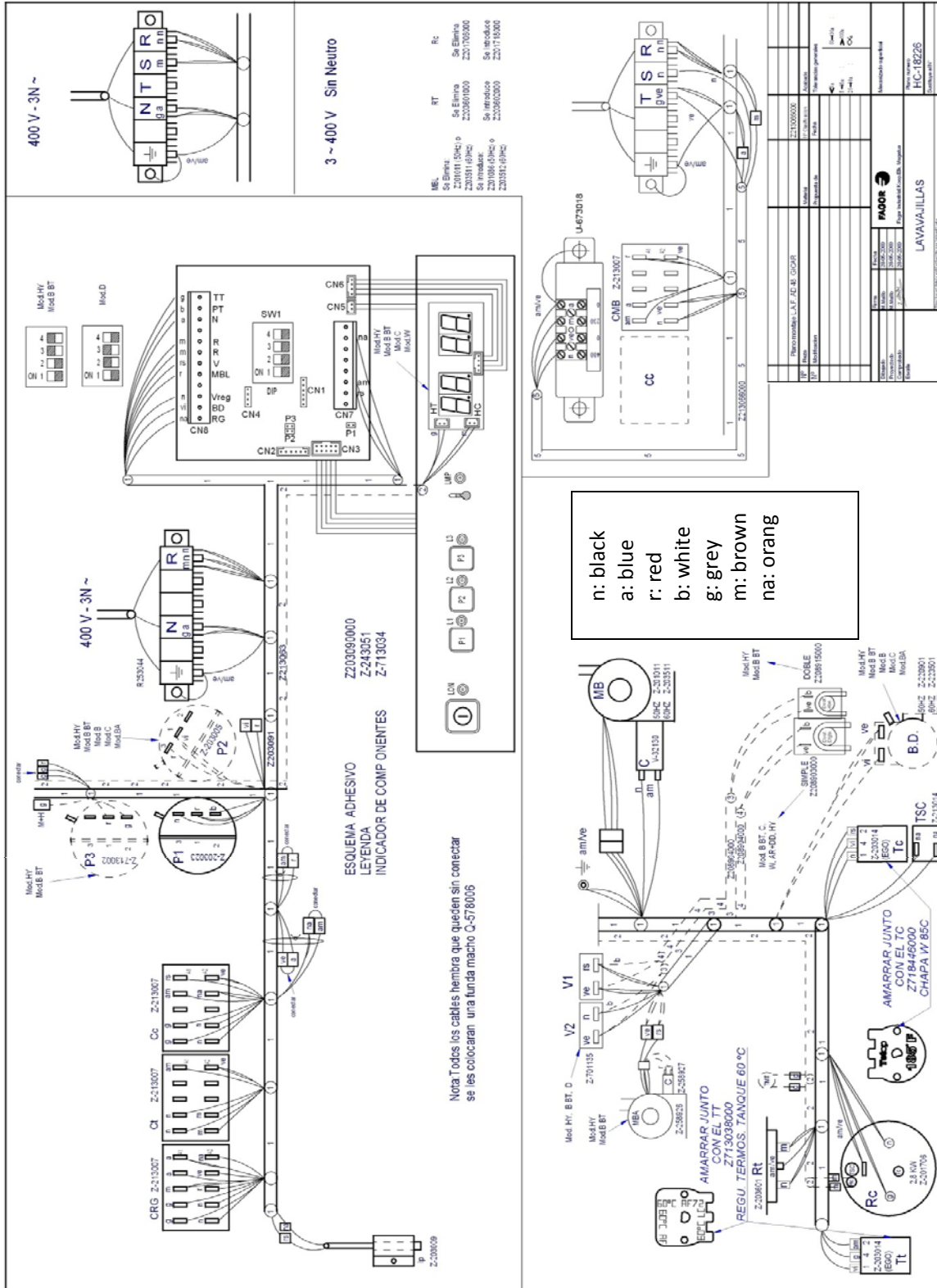

# AD-64 CW / AD-72

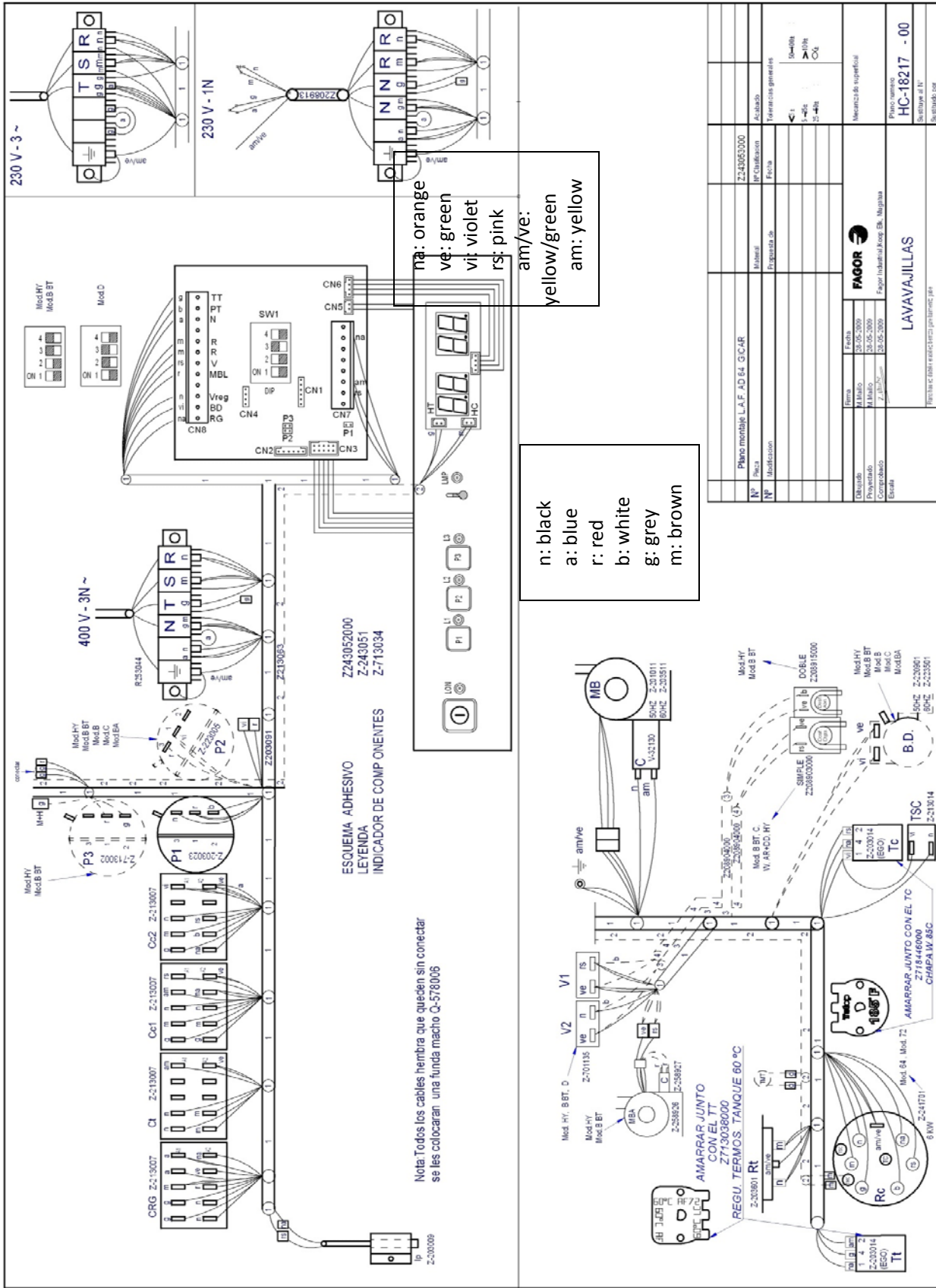

Plano montaje L.A.F. AD 64 - G.CAR		Fecha: 28.05.2009	
Nº Pieza	Material	Elaborado	Modificado
		28.05.2009	28.05.2009
Modificación		Z. de C.:	
		28.05.2009	
Tolerancias generales		30-10%	
		1-10%	
		25-40%	
		C.O.	
		Mecanica de sujeción	
Plano número		HC-18217 - 00	
Escalado		Escalado 1:1	
		Escalado 1:1	

Plano montaje L.A.F. AD 64 - G.CAR		Fecha: 28.05.2009	
Nº Pieza	Material	Elaborado	Modificado
		28.05.2009	28.05.2009
Modificación		Z. de C.:	
		28.05.2009	
Tolerancias generales		30-10%	
		1-10%	
		25-40%	
		C.O.	
		Mecanica de sujeción	
Plano número		HC-18217 - 00	
Escalado		Escalado 1:1	
		Escalado 1:1	

## RECOMMENDED SPARE PARTS

<u>AD – 48 W</u>		<u>AD – 64 CW, AD – 72 W</u>	
<u>Part Number</u>	<u>Description</u>	<u>Part Number</u>	<u>Description</u>
Z201720	Heating element for booster 2800 W. 230V.	Z241703	Heating element for booster 6000W. 230V.
Z203009	Door switch	Z203009	Door switch
Z213007	Contactora 230V. 50-60Hz.	Z213007	Contactora 230V. 50-60Hz.
Z203023	Level pressure switch	Z203023	Level pressure switch
Z203511	Pump Motor 60Hz.	Z203511	Pump Motor 60Hz.
Z203601	Heating element for tank 2800W. 230V.	Z203601	Heating element for tank 2800W. 230V.
Z211903	Rinsing nozzle	Z211903	Rinsing nozzle
Z213014	Safety thermostat	Z213014	Safety thermostat
Z223005	Safety pressure switch	Z223005	Safety pressure switch
Z701135	Water fill valve	Z701135	Water fill valve
Z203014	Tank / Booster thermostat	Z203014	Tank / Booster thermostat
V321300	10 MF Capacitor	V321300	10 MF Capacitor
Z223501	Drain pump	Z223501	Drain pump
Z231106	AntiReturn Valve	Z231106	AntiReturn Valve
Z213073	TIMER 5 RELES (Circuit Board)	Z213073	TIMER 5 RELES (Circuit Board)
Z218433	DISPLAY T <sup>a</sup> ADVANCE W	Z218433	DISPLAY T <sup>a</sup> ADVANCE W
Z218429	LABEL WITH BUTTONS ADHES. AD-48 W	Z218429	LABEL WITH BUTTONS ADHES. AD- 64 CW

## LIMITED WARRANTY

---

**One Year Parts & Labor Warranty:** Fagor Commercial, Inc. (“Fagor”) warrants to the first-end-user purchaser (the “User”) that the Fagor brand equipment sold hereunder, except for parts and accessories which carry the warranty of a supplier (the “Equipment”) will be free from defects in material and factory workmanship under normal conditions of use and maintenance for a period of (1) one year from the date of Installation (Warranty Commencement Date), but in no event to exceed (15) fifteen months from the date of shipment.

**Warranty Coverage:** If there is a defect in material or factory workmanship covered by this Warranty reported to Fagor during the period the applicable Warranty is in force and effect, Fagor will repair or replace, at Fagor’s option, that part of the Equipment that has become defective. Fagor will cover labor cost within one year from the Warranty Commencement date or 15 months from shipment date, whichever occurs first with the exception of the Glasswasher models, which will be 90 days labor and one year parts warranty. Fagor shall bear all labor costs in connection with the installation of these replacement parts, provided that, the installation is conducted by Fagor or its authorized representative. Charges for warranty travel time to round trip total (2) two hours or up to 100 miles. Any charges exceeding those stated herein must have prior authorization by Fagor. In case Fagor deems the equipment non-repairable, said equipment will be replaced and the replacement unit(s) will carry the same warranty period from the original unit’s installation date (Original Warranty Commencement Date).

**Exclusions from and Conditions to Warranty Coverage:** This Warranty does not cover parts or accessories, which (a) carry the warranty of a supplier or (b) are abused. Application of this Warranty is further conditioned upon the following:

- **Installation.** The Equipment must be properly installed in accordance with Fagor’s installation procedures and instructions and reviewed and tested by a professional technician.
- **No Alteration.** The Equipment must not have been modified or altered from its condition at the date of original installation.
- **Use.** FAGOR EQUIPMENT IS NOT DESIGNED FOR PERSONAL, FAMILY OR HOUSEHOLD PURPOSES, AND ITS SALE FOR SUCH PURPOSES IS NOT INTENDED. IN THE EVENT THE EQUIPMENT IS SO USED, THIS WARRANTY SHALL BE NULL AND VOID, AND THE EQUIPMENT SHALL BE DEEMED TO HAVE BEEN SOLD “AS IS-WHERE IS” WITHOUT ANY WARRANTY OF ANY KIND, INCLUDING WITHOUT LIMITATION ANY WARRANTY OF TITLE, NON-INFRINGEMENT, MERCHANT-ABILITY OR FITNESS FOR A PARTICULAR PURPOSE.
- **Water Quality.** Water supply should have hardness between .25 and 2.0 grains per gallon, pH level between 7.0 – 8.5 and TDS level at 250 PPM. Equipment failure due to inadequate water supply is not covered by this Warranty.
- **Proper Maintenance and Operation.** The Equipment must be properly maintained and operated in accordance with Fagor’s maintenance and operating procedures. All service, labor and parts must be acquired from Fagor or its authorized service representative for the User’s area.
- **Minor Parts.** No labor will be associated with the replacement of minor items such as, and not limited to, switches, pilot lights, gauges, fuses, etc. or replacement of wear items such as curtains, squeeze tubes, etc.
- This warranty is void if failure is a direct result of handling &/or transportation, fire, water, accident, misuse, acts of God, attempted repair by unauthorized persons, improper installation, if serial number has been removed or altered, or if unit is used for purpose other than it was originally intended.

Failure to comply with any of these conditions will void this Warranty. In addition, this Warranty does not cover defects due to apparent abuse, misuse or accident.

Fagor will have no responsibility to honor claims received after the date the applicable Warranty expires. Notwithstanding the foregoing, any claim with reference to the Equipment or any parts therefore for any cause shall be deemed waived unless submitted by the User to Fagor within thirty (30) days after the date the User discovered, or should have discovered, the claim. In connection with all claims under this Warranty, Fagor will have the right, at its own expense, to have its representatives inspect the Equipment at the User’s premises and to request all of User’s records pertaining to the Equipment to determine whether a defect exists, whether the conditions set forth in this Warranty have been satisfied, and whether or not the applicable Warranty is in effect.

THE FOREGOING WARRANTY IS IN LIEU OF AND EXCLUDES ALL OTHER WARRANTIES NOT EXPRESSLY SET FORTH HEREIN, WHETHER EXPRESS OR IMPLIED BY OPERATION OF LAW OR OTHERWISE, INCLUDING BUT NOT LIMITED TO ANY REPRESENTATION OF PERFORMANCE AND ANY IMPLIED WARRANTIES OF TITLE, NON-INFRINGEMENT, MERCHANTABILITY OR FITNESS FOR A PARTICULAR PURPOSE. NO OTHER WARRANTIES ARE AUTHORIZED ON BEHALF OF FAGOR UNLESS SPECIFICALLY ISSUED BY FAGOR.

**Fagor shall have no liability for incidental or consequential losses, damages or expenses, loss of sales, profits or goodwill, or punitive or exemplary damages directly or indirectly arising from the sale, handling or use of the Equipment or from any other cause relating thereto, whether arising in contract, tort, warranty, strict liability or otherwise. Fagor’s liability hereunder in any case is expressly limited, at Fagor’s election, to repair or replacement of Equipment or parts therefore or to the repayment of, or crediting the user with, an amount equal to the purchase price of such goods.**



**Fagor Commercial, Inc.**  
13105 NW 47<sup>th</sup> Ave.  
Miami, Fl. 33054  
Tel: (305) 779 0170  
Fax: (305) 779 0173  
1-866-GO-FAGOR  
[www.fagorcommercial.com](http://www.fagorcommercial.com)