

JOB NAME \_\_\_\_\_

SERIAL NUMBER \_\_\_\_\_



**Arctic**<sup>®</sup>  
WALK-IN COOLERS & FREEZERS

## Walk-In Installation, Operation, Maintenance & Warranty Manual

**IMPORTANT**

**WARRANTY  
REGISTRATION  
REQUIRED, SEE  
PAGE 32.**

**Manufactured By:  
Arctic Industries, Inc.**

9731 N.W. 114<sup>th</sup> Way, Miami, FL 33178  
(305) 883-5581 - Fax: (305) 883-4651  
Toll Free: (800) 325-0123  
<http://www.arcticwalkins.com>





# INSTALLATION MANUAL

## TABLE OF CONTENTS

<b>SECTION 1. GENERAL INFORMATION.....</b>	<b>2</b>
1.1 Introduction.....	2
1.2 Inspection.....	2
1.3 Handling of Panels.....	2
<b>SECTION 2. INSTALLATION.....</b>	<b>3</b>
2.1 Installation Procedure.....	3
2.2 Floor Panels.....	5
2.3 Wall Panels.....	5
2.4 Door Panels.....	6
2.5 Ceiling Panels.....	7
2.6 Floorless Walk-Ins.....	8
2.7 Outdoor Installation.....	10
2.8 Diamond Tread Plate Installation.....	13
2.9 Completing the Installation.....	14
<b>SECTION 3. MAINTENANCE .....</b>	<b>19</b>
3.1 Cleaning.....	19
3.2 Door Hardware.....	19
3.3 Ceiling Strength.....	19
<b>SECTION 4. SERVICE .....</b>	<b>20</b>
4.1 Door Closers.....	20
4.2 Door Heater Replacement.....	21
4.3 Door Sweep Replacement.....	22
4.4 Magnetic Gasket Replacement.....	23
4.5 Thermostat Adjustments .....	23
<b>SECTION 5. ELECTRICAL SCHEMATICS .....</b>	<b>24</b>
<b>SECTION 6. PARTS POLICY/ MINIMUM ORDERS.....</b>	<b>30</b>
<b>SECTION 7. SELF CONTAINED REFRIGERATION .....</b>	<b>31</b>
<b>SECTION 8. WARRANTIES.....</b>	<b>32</b>

# SECTION 1: GENERAL INFORMATION

## 1.1 INTRODUCTION

These instructions have been prepared to assist you with the erection and maintenance of your Arctic Walk- In Cooler/Freezer.

A single set of instructions can scarcely cover all situations, however, the following procedures apply to most installations and can be used as guidelines in all.

Your walk-in has been pre-assembled at the factory to insure proper match and fit of all panels. Each panel has been labeled with the appropriate number designation for walls, doors, floors and ceilings. All panels are pre-gasketed at the factory. A floor plan is provided to assist the installer in the assembly of the unit.

We suggest that you read and become familiar with these instructions before proceeding with the installation.

## 1.2 INSPECTION

The panels and optional equipment were inspected at the factory before shipment, however, freight damage or shortages can occur. Count and inspect your shipment carefully and describe on the delivery ticket any shortages or damage to cartons/pallets or contents before signing for the shipment. In the event that concealed damage is discovered after receipt of goods, save all packaging materials. REMEMBER, IF SHIPMENT IS PRE-PAID ARCTIC FILES THE CLAIM AND IF FREIGHT IS THIRD PARTY THE CUSTOMER FILES THE CLAIM AND ARCTIC ASSISTS.

## 1.3 HANDLING OF PANELS

Damage to the panel sections and accessories can occur if they are not handled properly during unloading or set-up. To minimize risk of damage, observe the following precautions:

1. Stack panels on a platform or protective material to avoid contact with ground moisture.
2. Protect panels from direct contact with any rough surface.
3. Avoid resting panels on their corners or edges and keep panels flat to prevent denting.
4. When handling panels over 12' long, hold panels vertically. If panels are to be handled flat the center section must be supported with additional manpower.
5. If panels must be kept in outdoor storage, cover them carefully with plastic sheeting or tarpaulin. Aluminum in contact with itself, other metals, or some packaging materials in the presence of moisture can become permanently stained.



# SECTION 2: INSTALLATION

## 2.1 INSTALLATION PROCEDURE

A review of the layout drawing which accompanies your walk-in will guide you in establishing the location of each panel. Segregate the different types of panels: floor, ceiling, wall and partition. This simple procedure will minimize handling and save labor. See Fig.1 & 2.

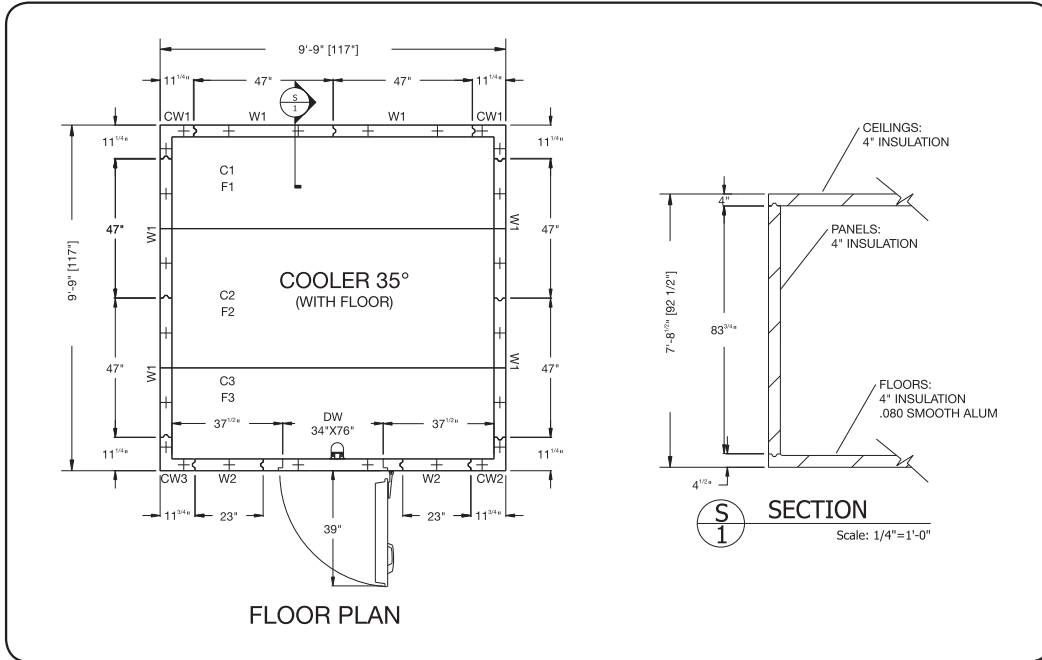

FIG 1. FLOOR PLAN

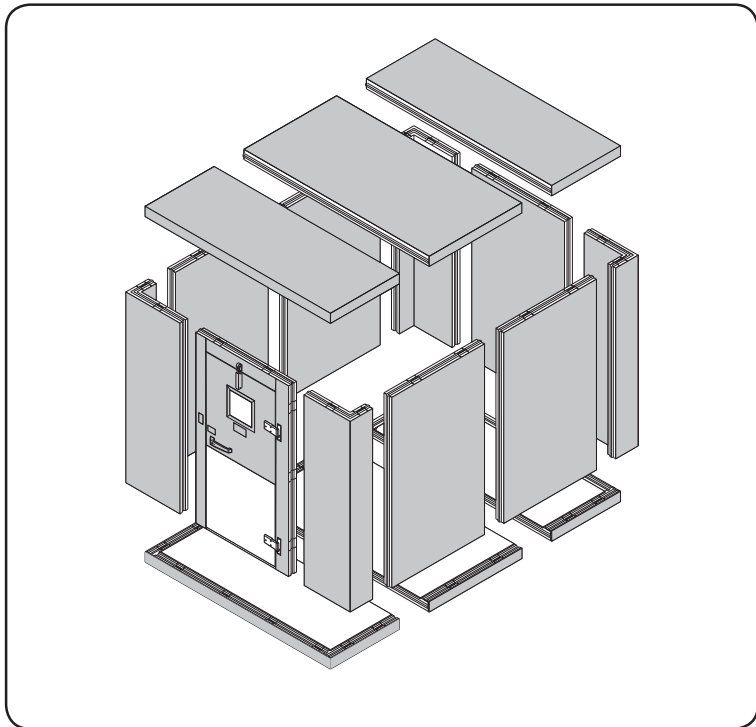

FIG 2. TYPES OF PANELS

Make sure that the walk-in area is free of debris and swept clean. A clear site will reveal any major surface unevenness and any irregularities on the adjacent building walls. For ease of installation, tight panel seams, and proper door operation the site floor or slab must be absolutely flat and level.

A minimum 2" clearance or "breathing space" should be allowed between the walk-in and adjacent walls. This clearance is necessary for air circulation to prevent moisture condensation, and to allow for any variation in building walls which may not be square or plumb. This clearance may not be practical depending upon field conditions, when an outdoor walk-in is against an exterior building wall and the walk-in roof cover must be flashed up to the building wall.

Pay particular attention to the location of self-contained top or side mount refrigeration units which must have sufficient space for service access and proper air circulation.

Next, chalk the perimeter outline of the structure and confirm its squareness by making diagonal measurements. If the corner angles are square, you are ready to start installation. See Fig. 3.

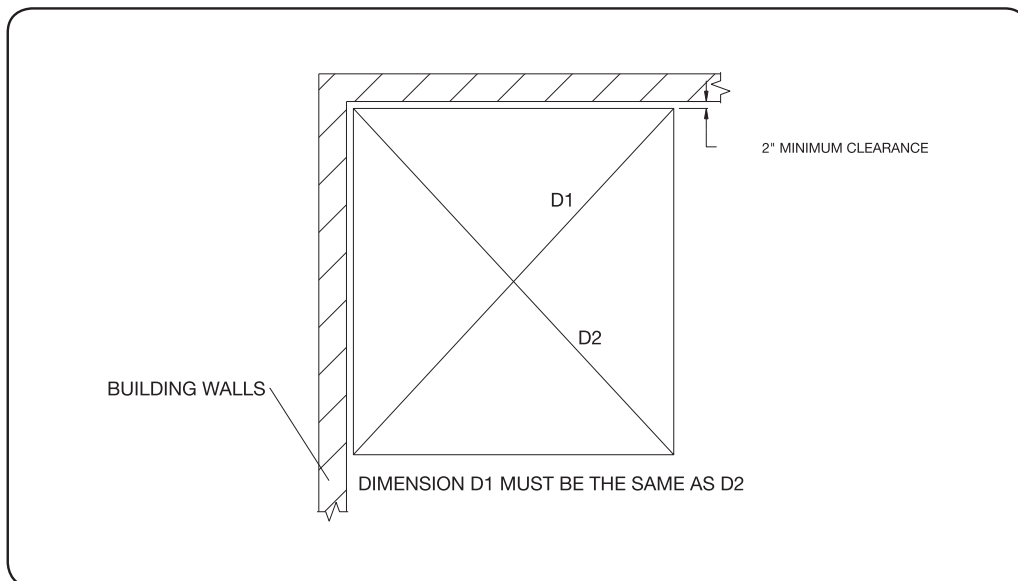

FIG 3. SITE LAYOUT

Take time to familiarize yourself with the construction of the panels and their interlocking mechanism.

All Arctic panels have tongue (male) and groove (female) perimeter edges. This interlocking design, along with the factory- installed edge gasket will result in an air-tight structure without additional caulking, if installed square and level.

All panels are equipped with locking devices set into aligned positions along the perimeter. See Fig. 4.

The male cam locks (with arm) are located in the tongue; the female locks (with pin) are located in the groove. Access to locking mechanism is provided through hole on the interior side of the panels.

**FIG 4. LOCKING DEVICES**

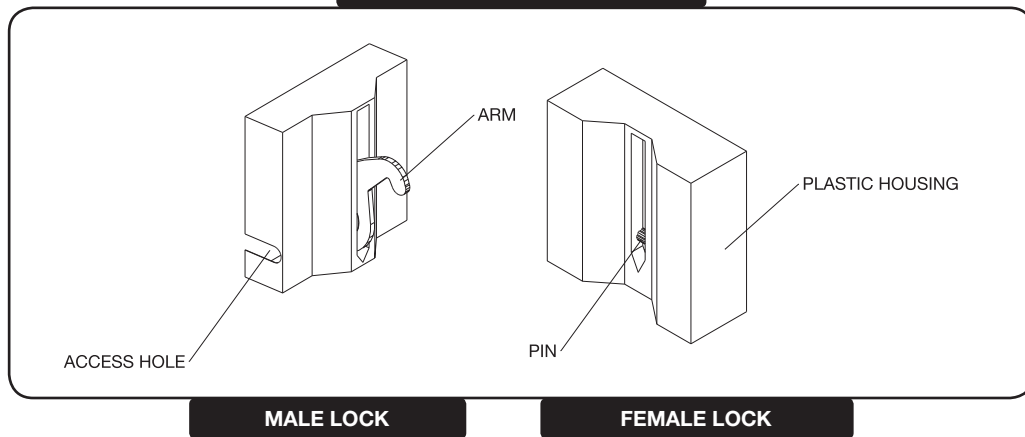

The hardware package includes an L-shaped 5/16” hex wrench. Insert the hex wrench into the hole in the panel and engage it firmly in the opening of the locking arm. FIRST TURN THE WRENCH COUNTER-CLOCKWISE TO CHECK THAT THE LOCKING ARM IS BROUGHT TO A COMPLETELY OPEN POSITION BEFORE JOINING PANELS: to lock, turn the wrench clockwise approximately 75 degrees to engage arm with pin. Cam action of the lock will pull the panels together, compressing their gaskets and providing an airtight seal.

Now check the installation drawing and study the general layout and specific panel location. All panels are labeled on the inside face to match the floor plan and to show their proper orientation (arrows on wall panels point up). The job number marked on the panel edge identifies all the panels for a particular job. In an installation with more than one separate walk-in, the job number will have a letter suffix to identify which panels correspond to which: -A,-B,-C,-D, etc.

Note that panels and lock locations are always described from the interior. From this vantage, the male (tongue) edges of wall panels are usually on the right.

## **2.2 FLOOR PANELS**

A moisture barrier of 4-mil polyethylene must be laid between floor panels and existing floor and overlapped at least six inches at joints (to be supplied by others).

Start with a floor end section in the proper location according to the floor plan. Floor panels must be level on both length and width. Next, place the appropriate adjoining center or end section into position. Ensure that all edges are flush and level, then lock the panels together and again check for levelness. As you proceed with the assembly of the floors, check that the chalk line is being followed. Complete the assembly of the remaining floor panels in the same manner.

## **2.3 WALL PANELS**

Review the floor plan and select a pair of corner panels to start the assembly of the walls. We suggest that you start with the most inaccessible corner or one adjacent to your building wall. Locate the panels even with the outside of the floor and partially lock them into position. Now select a wall panel to install on the right side of the corner. Lock this panel firmly to the corner in such a way that their tops are level. Partially lock the wall to the floor panel.

## 2.4 DOOR PANELS

When installing doors, first remove the door plug from its frame section. This is easily done by opening the door approximately half-way and then lifting it off its hinge pins. Proper door operation requires that the door frame members be perfectly plumb and square. Replace the door in its frame before securing the jambs to the floor and check to see that the door closes, seals, and locks properly. Cooler door frames without heater cables are shipped with a metal spreader plate joining the two frame legs at the bottom. This should be removed before fastening the frame to the floor. Secure door frame legs to the interior floor, using the door frame brackets and screws provided.

**NOTE:** Door and frames have been checked for proper fit and operation at the factory. An unlevelled floor may cause doors to not hang or close properly. This can occur initially at the time of installation or at a later date due to heavy traffic. It may be necessary to shim under walk-in floor or door frames at one side or the other to adjust a misaligned frame. Loosening and relocking frame cam locks may also permit some adjustment. Make sure frame legs are parallel to each other and to adjacent wall panels. The door may not seal properly if the frame is twisted or out of plumb. See Fig. 5.

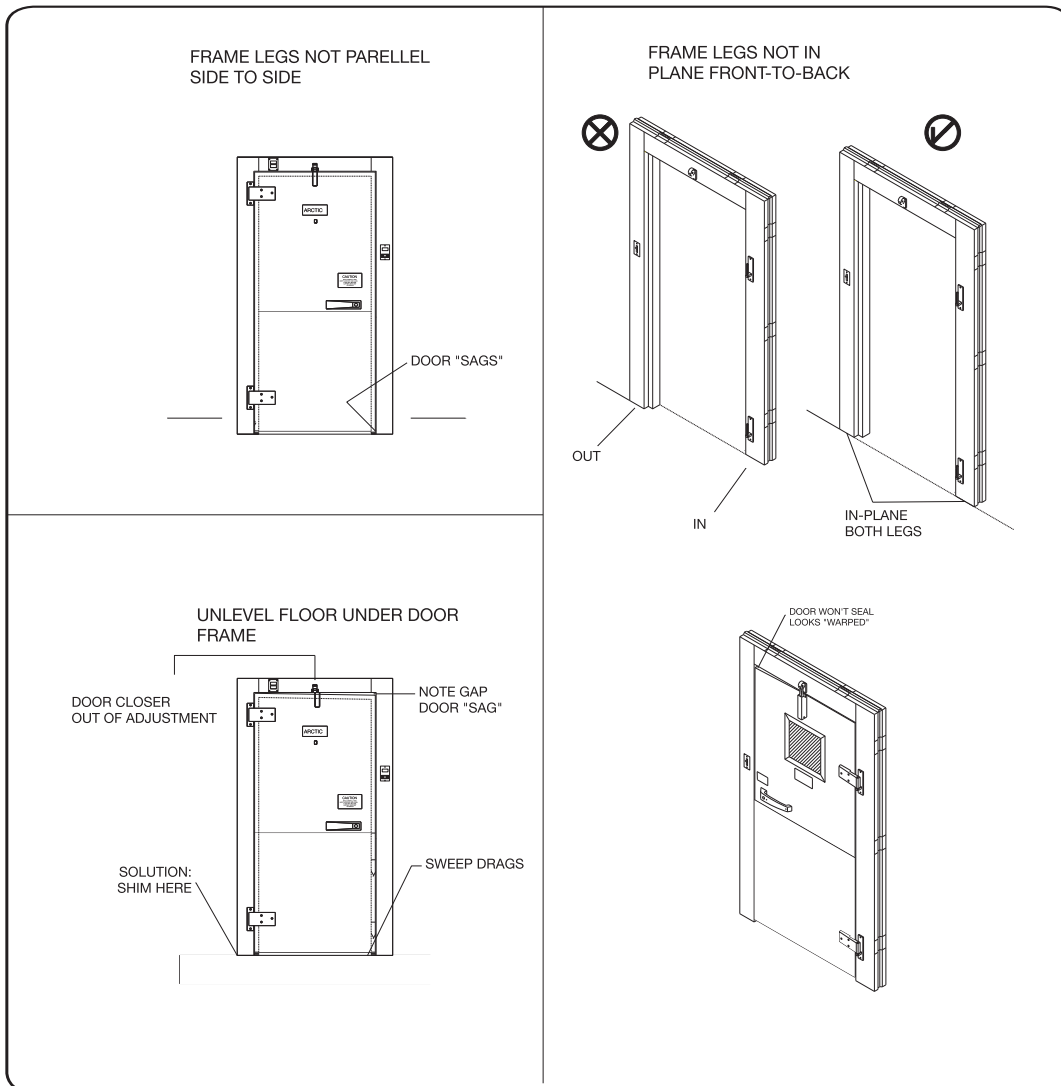

FIG 5. INSTALLATION DOOR PROBLEMS

## 2.5 CEILING PANELS

Refer to the floor plan and select the end ceiling panel adjacent to your building wall. Place this panel into position and carefully align it with the corner and side wall. Lock it firmly to the corners and along back wall, but not to the side walls. Select the next ceiling panel, as shown on the floor plan, and carefully align it with the edges of the end ceiling and the walls.

After you are satisfied with the alignment, firmly lock the ceilings together along the center seam, but lock only loosely to the walls.

Continue placing ceiling panels in the same manner, until the opposite end section is installed. Now carefully check the alignment of the ceiling with the corner and perimeter walls, and once you are satisfied, complete the firm locking to the wall panels.

For ceiling panels with clear span over 13'8" in both directions, ceiling support may be supplied as shown in Fig. 6.

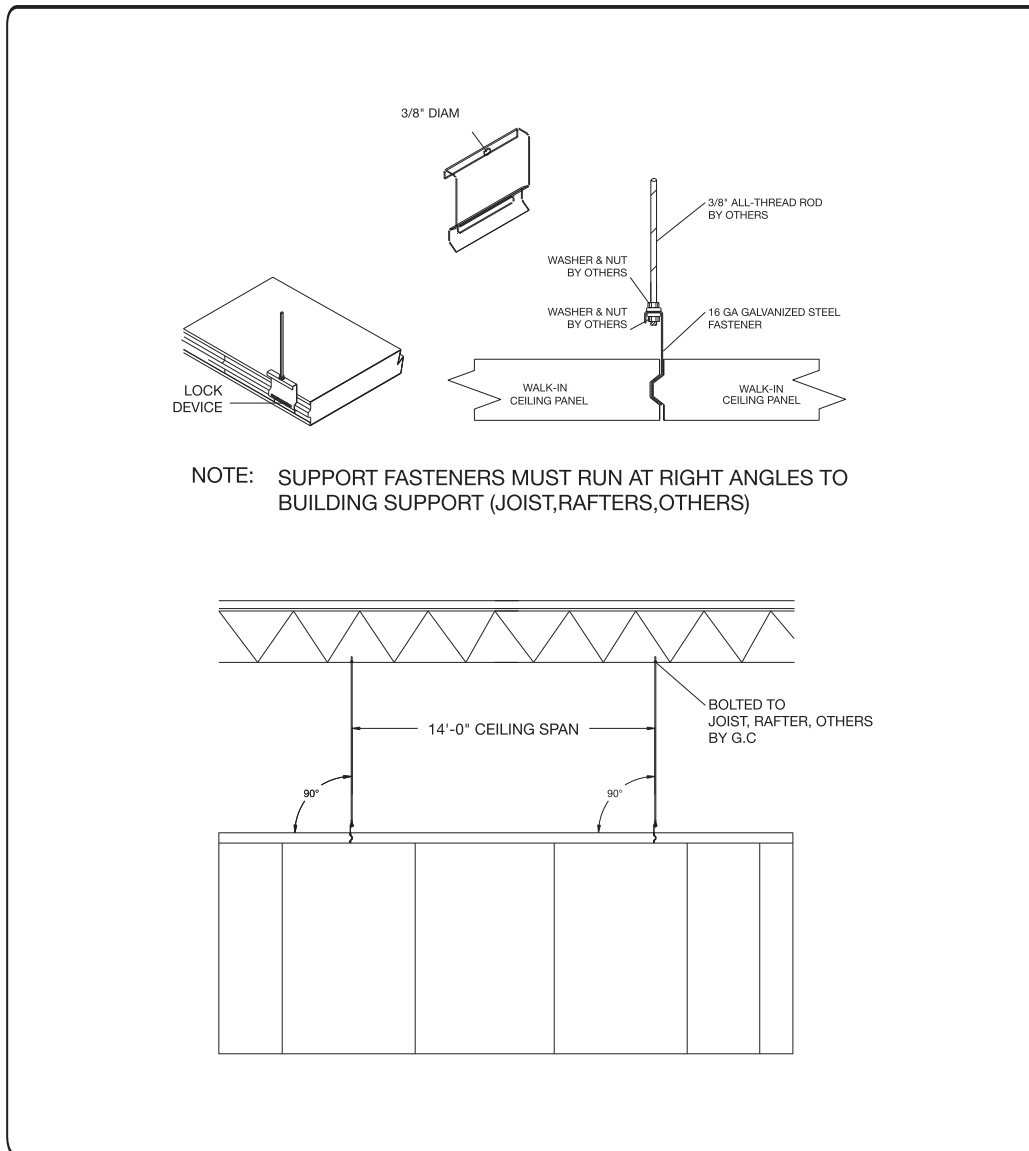

**FIG 6. CEILING SUPPORT**

## 2.6 FLOORLESS WALK-INS

### 2.6.1 Coolers

Floorless coolers are provided with a vinyl floor screed which should be placed along the chalk lines described in Section 2.1. A bead of caulk should be applied on each outside bottom edge, between the floor and the screed to compensate for any minor irregularities in the building floor. Check squareness of the corners, check dimensions and then secure the screed into position with the concrete nails included as shown in Fig. 7.

The factory provides enough tubes of caulk for a typical installation; however, more may be needed if the building floor or slab is particularly rough.

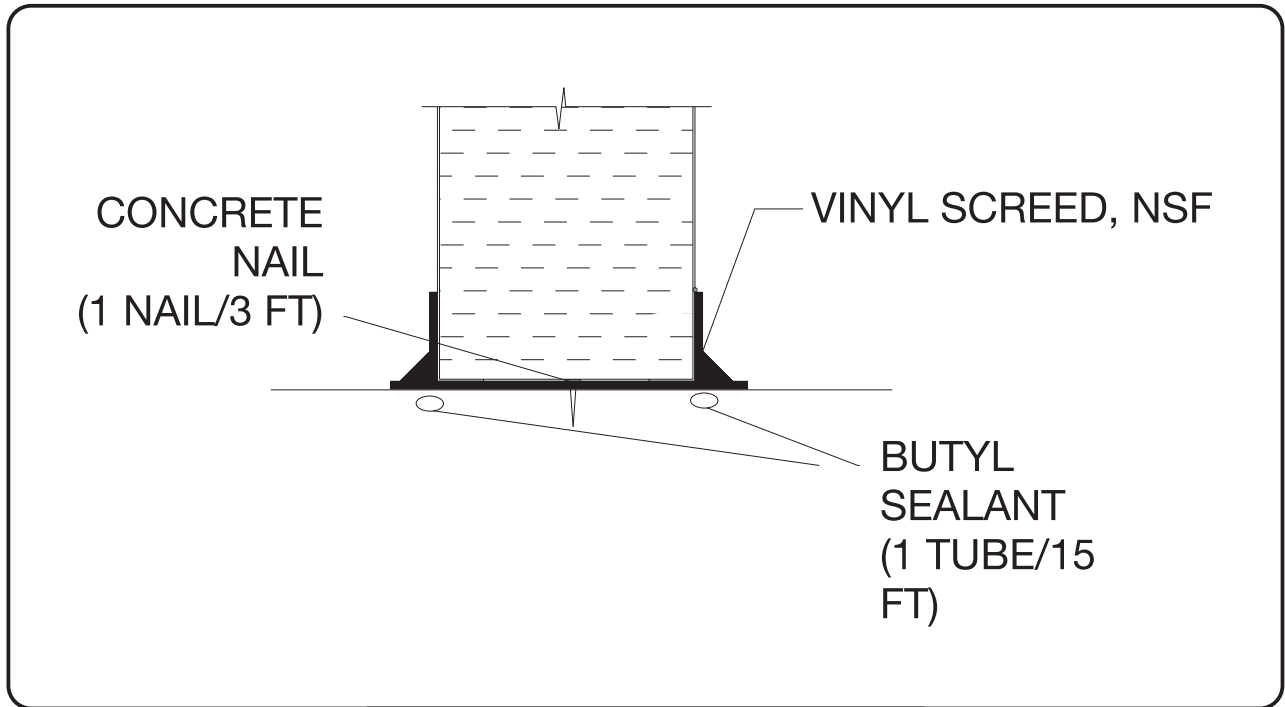

FIG 7. FLOOR SCREED

### 2.6.2 Freezers

“Floorless” freezers require an insulated sub-floor. This is commonly achieved with a poured concrete slab over insulation incorporating a vertical thermal barrier under the walk-in walls between the insulation and the slab’s surface as shown in Fig 8.

In this application, Arctic normally provides interior and exterior aluminum floor angle to attach the walls to the floor. As in Section 2.7.3 the angle, after caulking, is attached to the floor with anchor bolts or concrete nails and to the walk-in walls with sheet metal screws.

Care must be taken not to chip the edges of the slab.

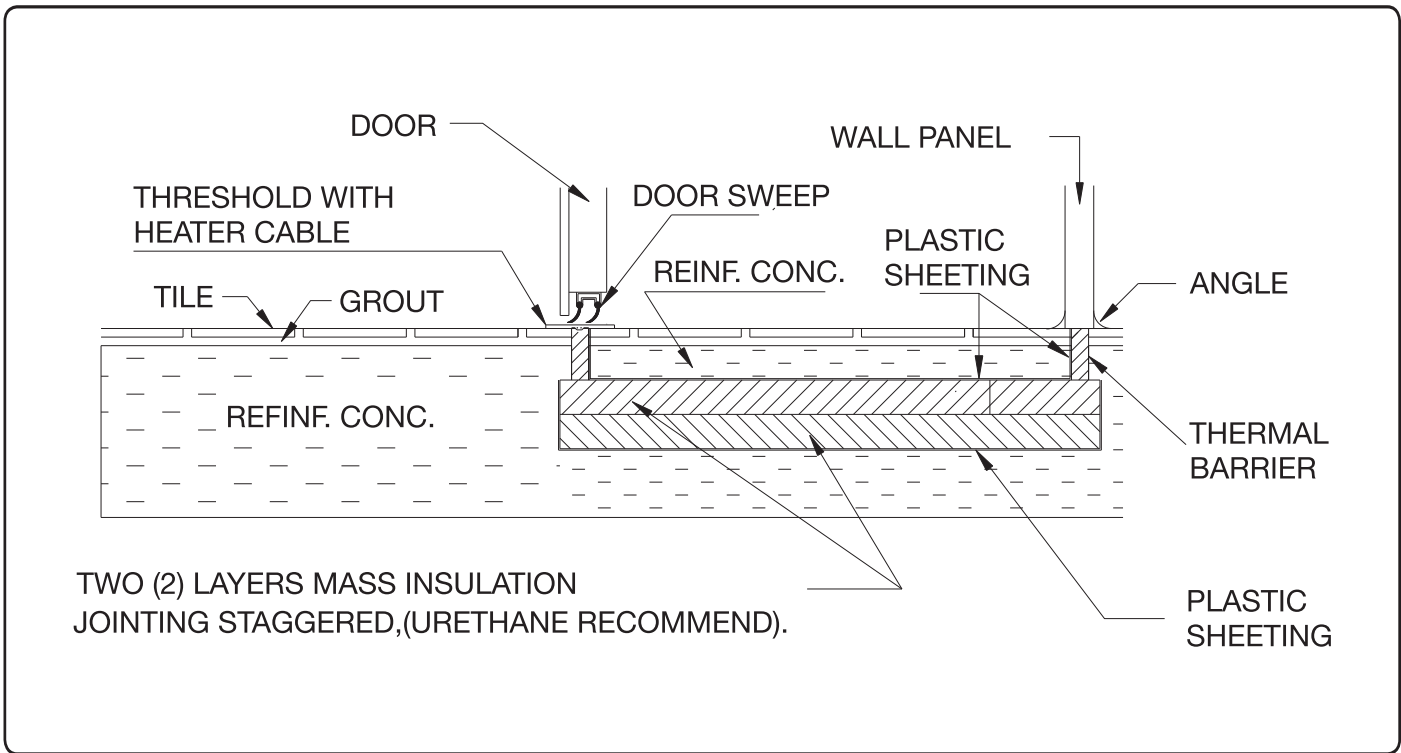

**FIG 8. INSULATED SLAB**

**2.6.3 Combinations**

For combination Walk-ins with a floorless cooler section and freezer with a floor, a half- screed piece is provided for the edge of the freezer within the cooler section. This piece must be attached beneath the freezer floor to match the rest of the screed on the interior of the cooler section as shown in Fig. 9.

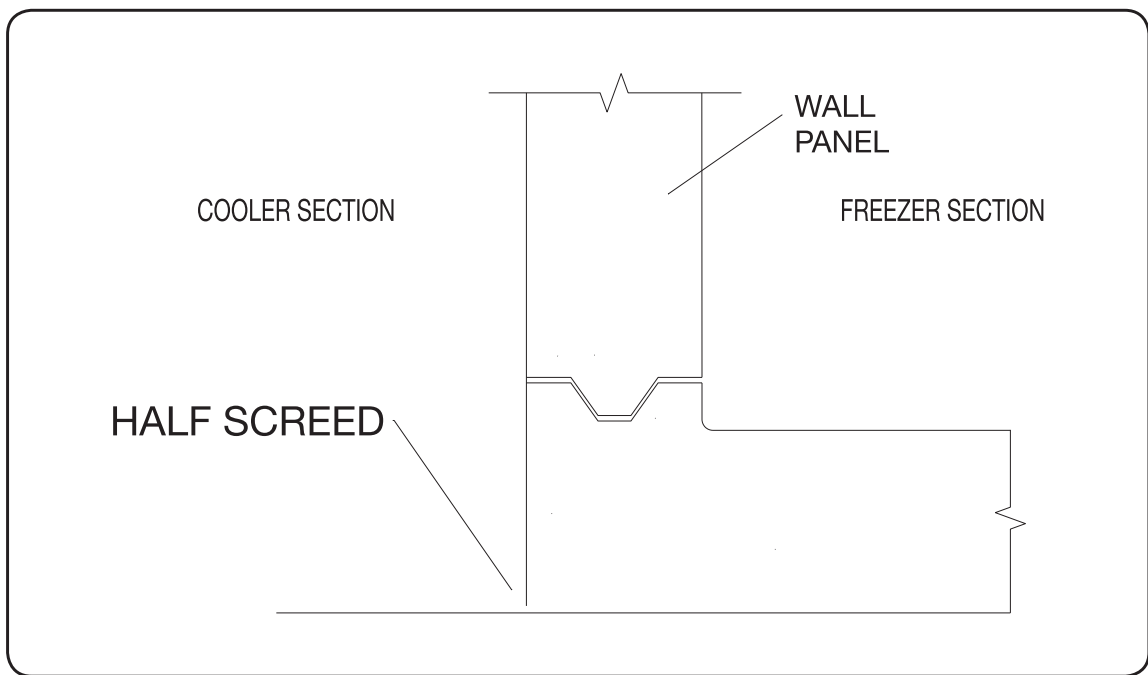

**FIG 9. COMBINATION: COOLER FLOORLESS /FREEZER WITH FLOOR**

## 2.6.4 Doors

Door frames are attached to the floor in the same manner as walk-ins with floor except that concrete anchors must be used. Cooler doors are provided with threshold plates only in the special cases where a heater is requested; therefore the metal “shipping brace” must be removed from the bottom the door frame legs before the legs are attached to the floor (see Section 2.4).

**NOTE:** Shipping brace not shown on Fig. 6.

## 2.7 OUTDOOR INSTALLATION

### 2.7.1 Roof Covers

Walk-Ins installed outdoors must be protected with a roof cover. Arctic offers two types: a one-piece membrane cover or a formed sectional aluminum cover. If an aluminum roof cover is ordered, manufacturer’s installation instructions will be provided separately.

**The membrane roof consists of:**

1. Membrane roof cover
2. Termination Bars
3. 1” Phillips head sheet metal screws
4. 1” Hex head screws with neoprene washers
5. 2” Flat head plates
6. Caulking

**The following procedure must be followed to insure proper weather protection:**

1. Unpack your roll, being careful not to cut the membrane.
2. Unroll the membrane over the roof area, being sure the tabs are on the underside. Roof area to be free of all debris.
3. Maneuver and/or shift the membrane so it fits squarely over the roof area, allowing equal amounts of membrane to overhang on the edges of the roof. If windy conditions are present, use concrete blocks, tires, lumber, etc., around the perimeter to keep the wind from lifting the membrane.
4. Once the membrane is centered on the roof, either fold or rolls the membrane back towards the center of the roof so the underside tabs are exposed. The roll or fold must be parallel to the factory seam and tab.
5. When you reach the tab going in the opposite directions, stop rolling or folding.
6. Now begin to roll or fold the roll back until a tab is exposed.
7. The tab should be flat on the roof deck.
8. Install the fastener/plate assembly, keeping them spaced 12” off center (O.C.). Do not strip the screw out.



9. Continue to roll the roll until the next tab is exposed and in place, ready for fastening.
10. Pull this tab tightly to reduce any wrinkle that may occur between tabs. Once pulled tight, hold in position until secured by a couple of fasteners.
11. Install the fastener assembled again along the tab 12" O.C.
12. Continue steps 10 & 11 until reach the last tab.
13. Now repeat the same process, only starting at the other end of the roof, following the same procedures.
14. You should have at least six inches of membrane overhanging the edge of the roof. Holding this overhang tight, down over the edge, install the termination bar at least 5" below the horizontal roof. If the term bar has a caulking lip, have the lip on the upside.
15. Fasten the term bar 12" O.C., using fasteners with neoprene washers.
16. After all term bar is attached, trim excess membrane that is exposed under the bar with a sharp knife, using the bottom edge of the bar as a cutting guide.
17. Now caulk the top edge of the bar with the caulking provided. Your roof should now be completed. See Fig. 10.

**NOTE**

1. Keep sharp objects off the roof, such as nails, screws, etc. Someone stepping on them could puncture the membrane.
2. The membrane is very slippery when wet.
3. Any puncture or holes that may occur during installation can be temporarily repaired with duct tape or caulking. A final repair must be done using a heat gun.
4. Do not drop hot cigarettes or objects on the membrane.

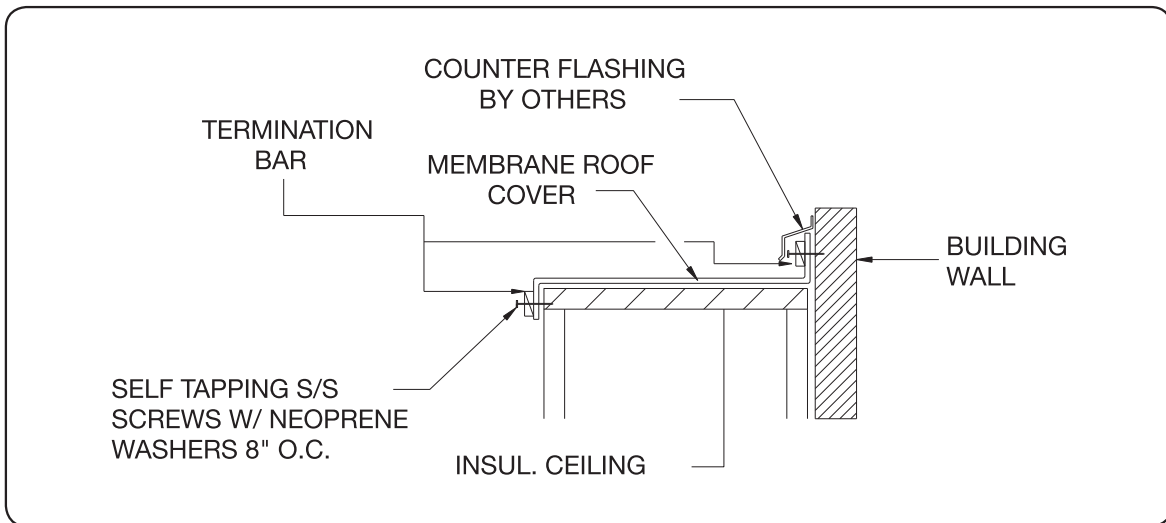
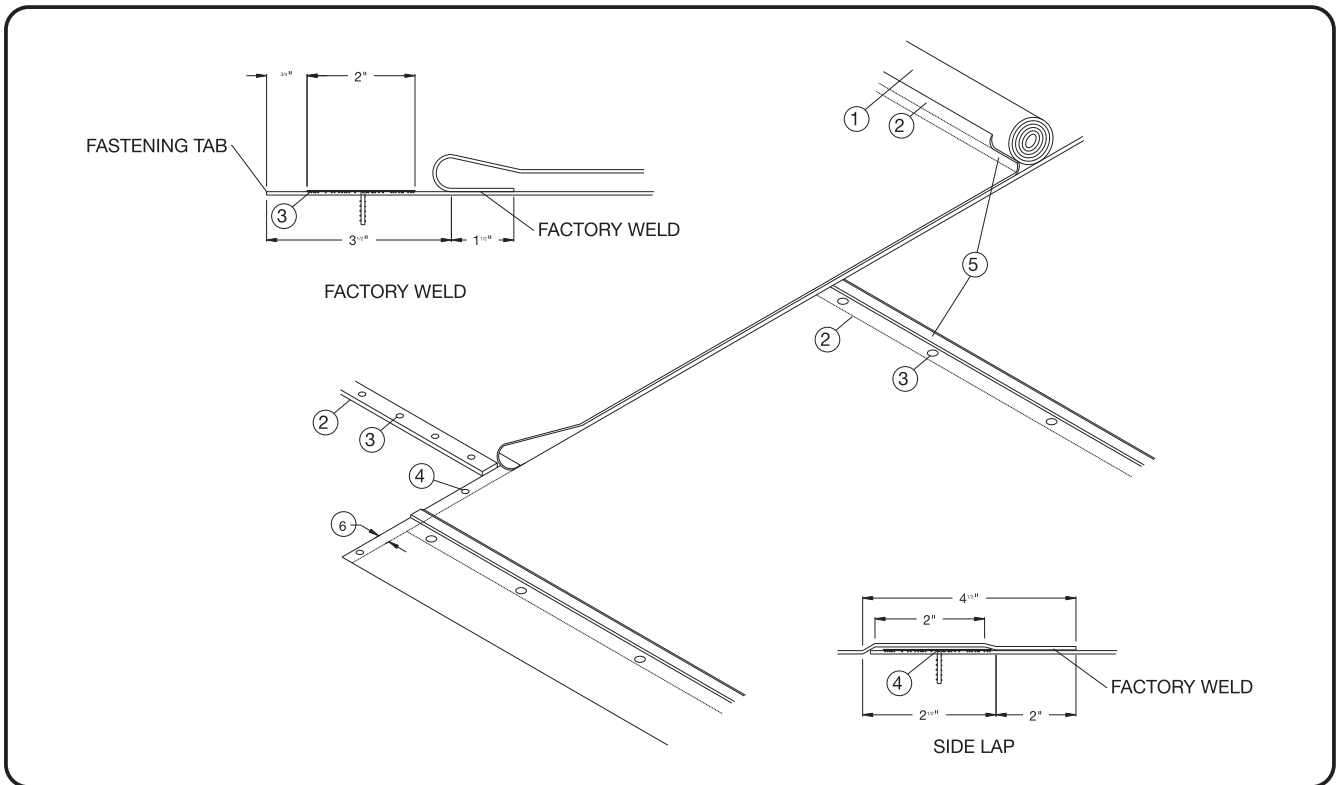

**FIG 10. TYPICAL MEMBRANE COVER INSTALLATION**

**MEMBRANE ROOF ROLL-OUT AND FASTENER PLACEMENT DRAWING:**

1. PANELED ROLL.
2. FACTORY TAB.
3. APPROVED FASTENER W/BARBED STRESS PLATE.
4. APPROVED FASTENER W/BARBED STRESS PLATE APPROXIMATELY 27" O.C.
5. FACTORY WELDS, STAGGERED EQUIDISTANT BETWEEN FACTORY WELDS OF ADJACENT ROLLS 27" O.C.
6. SIDE LAP ROLL TO ROLL MINIMUM 4 1/2".

**NOTE: ROLL REMAINS BEHIND PREVIOUSLY FASTENED TAB DURING ROLL-OUT.**



**FIG 11. MEMBRANE ROOF ROLL-OUT AND FASTENER PLACEMENT DRAWING**

**2.7.2 Door caps**

For free-standing walk-ins where the door is exposed, Arctic offers a door cap to prevent rain water from running down into the door gasket. The cap should be attached with sheet metal screws supplied by Arctic to the frame above the door, caulk the joint between cap and wall to prevent leaks.

**2.7.3 Box-to-Slab Attachment**

An outdoor walk-in usually placed on a raised concrete slab. Local codes may require that the walk-in attached to the slab using the perimeter angle provided. This angle is attached to the edges of the walk-in floor or walls with sheet metal screws and to the slab with concrete nails and anchor bolts supplied by Arctic.

Be sure to allow enough distance between the edge of the walk-in walls/floor and the end of the slab to prevent the edges from cracking away due to pressure of the fasteners.  
Apply sufficient caulking between the angle and both slab and walk-in to deter water infiltration.

## 2.8 DIAMOND TREAD PLATE INSTALLATION

Beer coolers and other walk-ins subject to heavy use, frequently require an overlay of aluminum diamond tread plate on the walls and/or floors. D.T.P. should be applied prior to start-up of refrigeration.

### 2.8.1 Wall Panels

1. Remove all dust, dirt, grease, etc. from wall panels and back of D.T.P. using mild soap, and allow panels to dry.
2. Lay out D.T.P. in appropriate order. With complicate lay-outs D.T.P. will be marked on back with a code number that corresponds with a code number shown on the drawing that accompanies the walk-in.
3. Apply adhesive (supplied) to rear (smooth side) of D.T.P. in a serpentine patters.

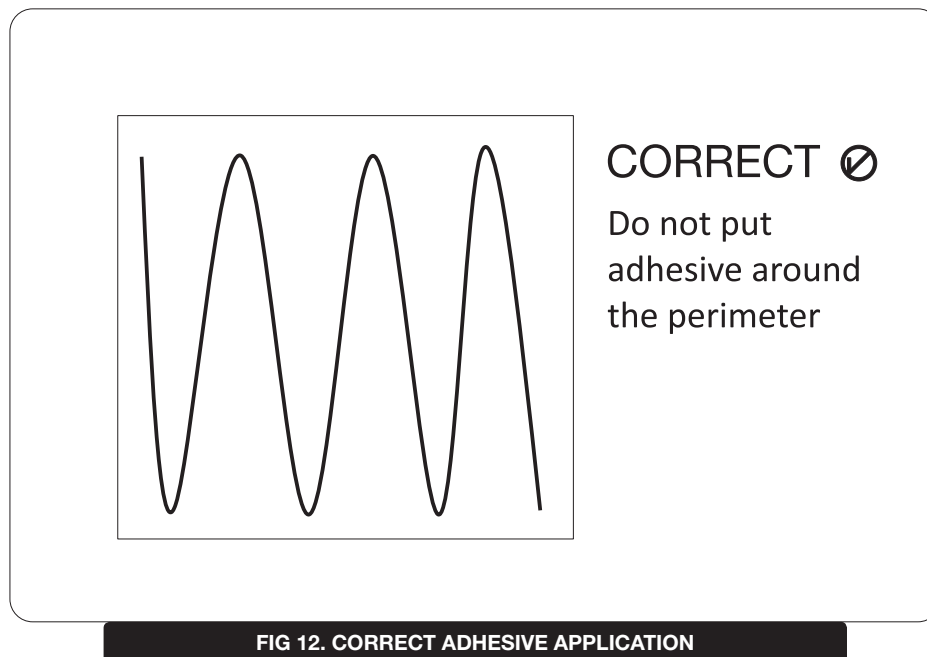

FIG 12. CORRECT ADHESIVE APPLICATION

Do not apply adhesive around perimeter of D.T.P. as this will prevent air from reaching all of the adhesive which will slow the curing process. A thin line of adhesive is recommended to make contact with wall panel. One tube of adhesive to every 4' x 10' sheet of D.T.P. is more than sufficient. See Fig. 12.

4. Apply pressure, making sure that adhesive has made contact with panel. The adhesive will hold D.T.P. in position while fastening the D.T.P. with #8 X ¾ self-drilling screws every 12".
5. Allow 24 hours at ambient temperature to allow adhesive to cure. Leave doors open to allow for proper ventilation of walk-in.
6. After 24 hours, apply silicon (supplied) on exposed edges and corners of D.T.P. to fill any gaps.

## 2.8.2 Floor Panels

1. Installation is essentially the same as for wall panels.
2. All D.T.P. floors are integral and the seams should be bedded in a 4" wide band of USDA silicone caulking (provided) to inhibit moisture from seeping through the seams of the D.T.P. Allow sufficient time for caulking to cure prior to start-up of refrigeration.
3. TEKS screws are provided to fasten D.T.P. to floor.

## 2.9 COMPLETING THE INSTALLATION

Several tasks remain to complete the installation of your Arctic Walk-In. Some of these are the installer's responsibility while others must be performed by qualified electrical and refrigeration contractors.

### 2.9.1 By Installer

1. Install snap-in plastic caps to seal cam-lock access holes.
2. Fasten down thresholds, if provided. Make sure that any door heater wires are not frayed or pinched.

**NOTE:** Thresholds with anti-condensate heater wires under them (all freezers, some coolers) must be made to be removable in order to change the wire should it fail. Never allow tile or concrete to cover either threshold or its fasteners.

**TO GENERAL CONTRACTOR AND SUB-CONTRACTOR:** Walk-ins with tile or concrete wearing floors when installed after box, the metal wall facings may be susceptible to staining due to excessive moisture created by hydration of concrete type materials. It is essential that each room be properly ventilated (doors kept open), when pouring concrete, grout/tile, particularly when using muriatic acid, due to the effects of fumes on metal finishes.

In addition metal surfaces must be protected from lime and other chemicals found in cement products. Protection must be applied between concrete and the metal surfaces (for example, liquid tar brushed or sprayed above the concrete contact line, heavy epoxy paint, double-layered 8-mil H.D. polyethylene, or 30 lb. asphalt-impregnated roofing paper).

### 2.9.2 By Electrical Contractor

Run electrical power supply (115V-3-Wire) to the light fixture which also serves as a connection box. The penetration can be made through a ceiling or wall panel, and must be properly sealed both interior and exterior.

**NOTE: TO PREVENT CONDENSATION FROM FORMING INSIDE, ELECTRICAL CONDUIT MUST BE SEALED INTERNALLY WHERE IT ENTERS COLD SPACE.**

Wall or ceiling penetrations must not interfere with panel seams or locking devices. The door heater, when supplied is pre-wired at the factory for continuous operation independent of the light switch, once the walk-in temperature reaches approximately 40 degrees F.

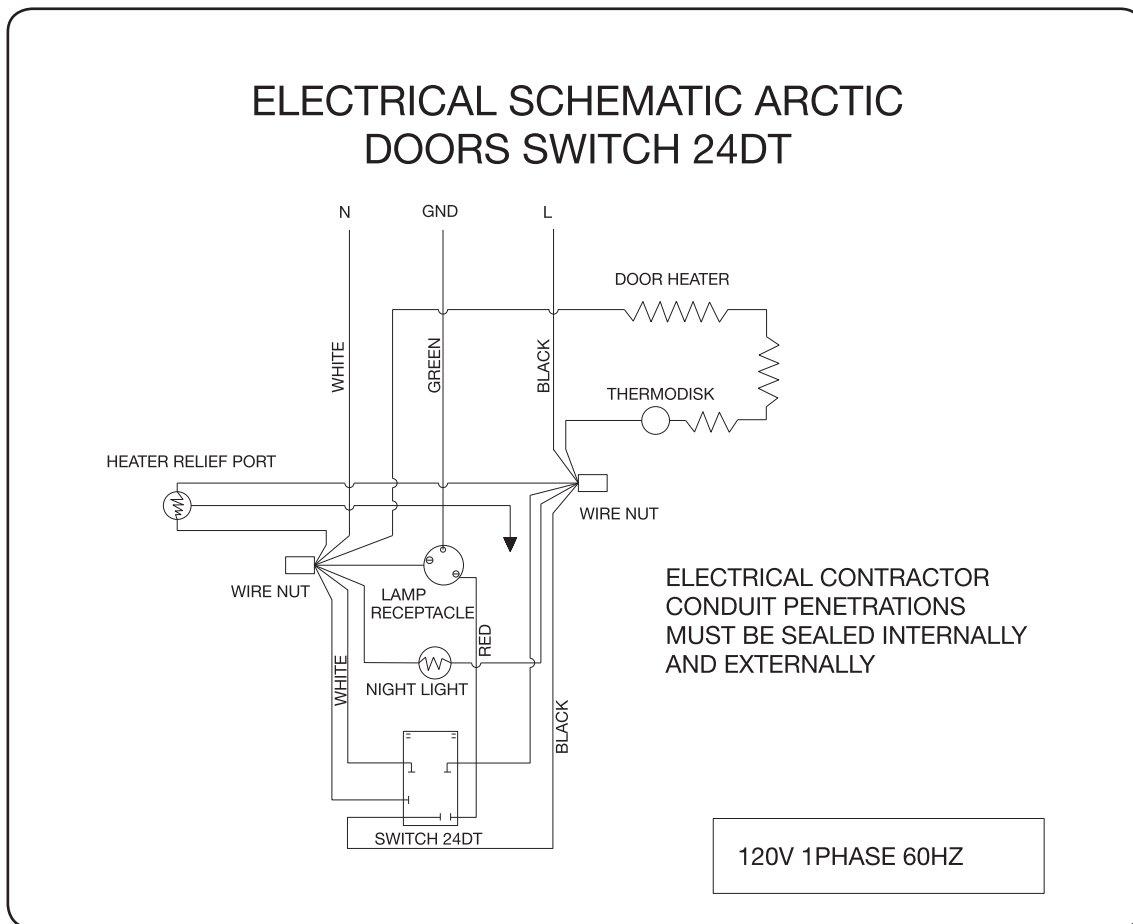

**FIG 13. ELECTRICAL SCHEMATIC FOR ARCTIC DOORS**

In freezer sections, a heated pressure relief port is provided and is connected as shown in Fig. 13.

Run power to the mechanical refrigeration equipment as required. Simplified wiring diagrams will be found on the last pages of this manual.

Be sure to use an electrical seal-off on the exterior of the walk-in wherever lines penetrate the exterior metal surface. Do not penetrate the roof cover of outdoor walk-ins.

All connections should be made to comply with national and or local codes.

### 2.9.3 By Refrigeration Contractor

Install mechanical refrigeration equipment in compliance with national and or local codes.

Drill clean holes through the walk-in wall for condensate drain and refrigerant lines. **DO NOT PUNCH.** All penetrations must be clear of panel seams and locking devices and be sealed completely on both sides panels. Low temperature systems include a 6' drain-line heater cable which should be wrapped around the drain line to prevent freezing. If a longer drain heater cable is required it must be provided by others. The use of PVC for freezer drain lines is not recommended; soft copper should be used. On self-contained units, be sure to uncoil the drain line heater before applying power or the heater will be damaged.

Low temp systems also include a defrost timer which must be set by the installer to initiate the time, and control the duration of defrost cycles. The frequency of cycles is determined by the usage of the walk-in (frequency of door openings, ambient temperature and humidity as well as product load) and their duration by the amount of frost to be removed, Keep both to a minimum necessary to maintain temperature and keep evaporator coil free of built-up frost.

Evaporator fans should run continuously on medium temperature systems and intermittently (off during defrost) on low temperature systems. Low temp fans do not come on until evaporator temperature gets down to about 25 degrees. See evaporator manufacturer's instructions for specific installation and operation details.

### 2.9.4 Self-Contained Units

Self-contained refrigeration units are fully inspected and tested at the factory, prior to shipment. WE STRONGLY recommend that start-up be performed by a qualified refrigeration contractor as variation in field conditions such as altitude, walk-in temperature, product load, ambient temperature and humidity frequently require adjustments to thermostat, pressure control or defrost settings. Operations in extreme low ambient conditions may require additional refrigerant. Extreme high ambient conditions may require additional accessories. Side-mount units must be attached to the frame of their wall openings using the same carriage bolts which secure them to their shipping crates. Top-mount units are placed in their openings with no need of attachment.

It may be convenient to place the ceiling-panel top-mount unit in its opening before the ceiling panel is lifted into place. In most cases additional installers can lift the panel and unit together. Heavier units may require the use of mechanical lifting equipment.

#### INSTALLATION INSTRUCTIONS FOR STRADDLE UNITS:

1. Do not install ceiling panel (s) over intended straddle unit locations.
  2. Mount straddle unit onto wall panel through cut-outs.
- NOTE: Upright support channel should rest flush against wall panel (See Fig. 14, 15).**
3. Fasten interior angle to straddle unit (Fig.16).
  4. Install ceiling panel (s) and lock into place.
  5. Adjust leveler and secure in place (top mount only). Put self-adhesive foam padding under foot to protect roof cover.
  6. Apply permagum (supplied) around cut-outs to insure a tight seal.

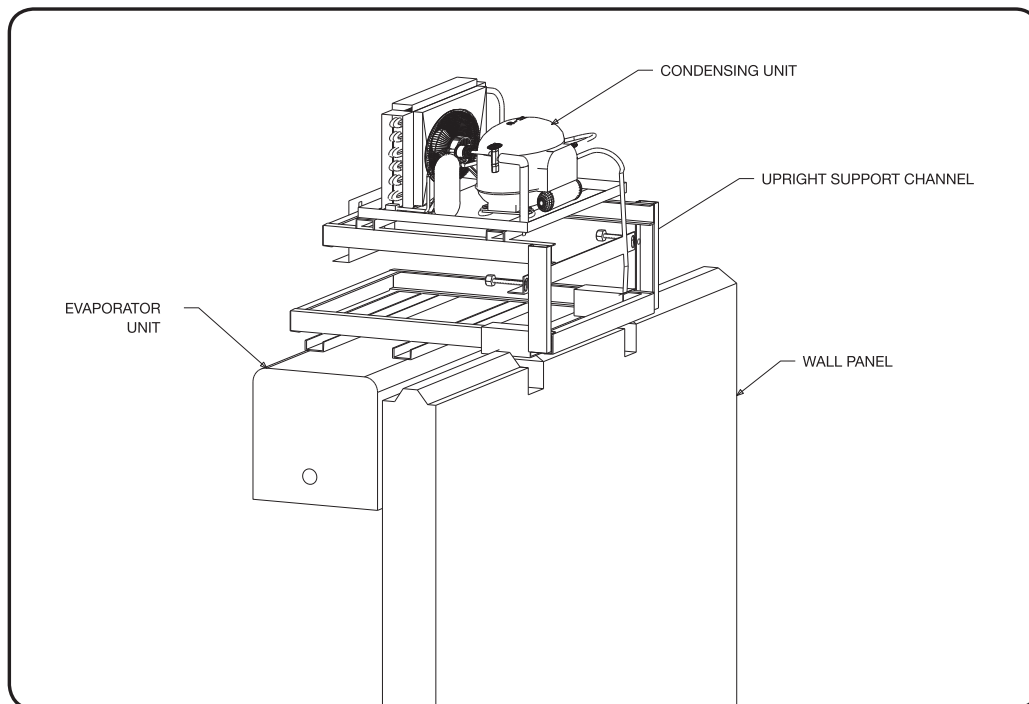
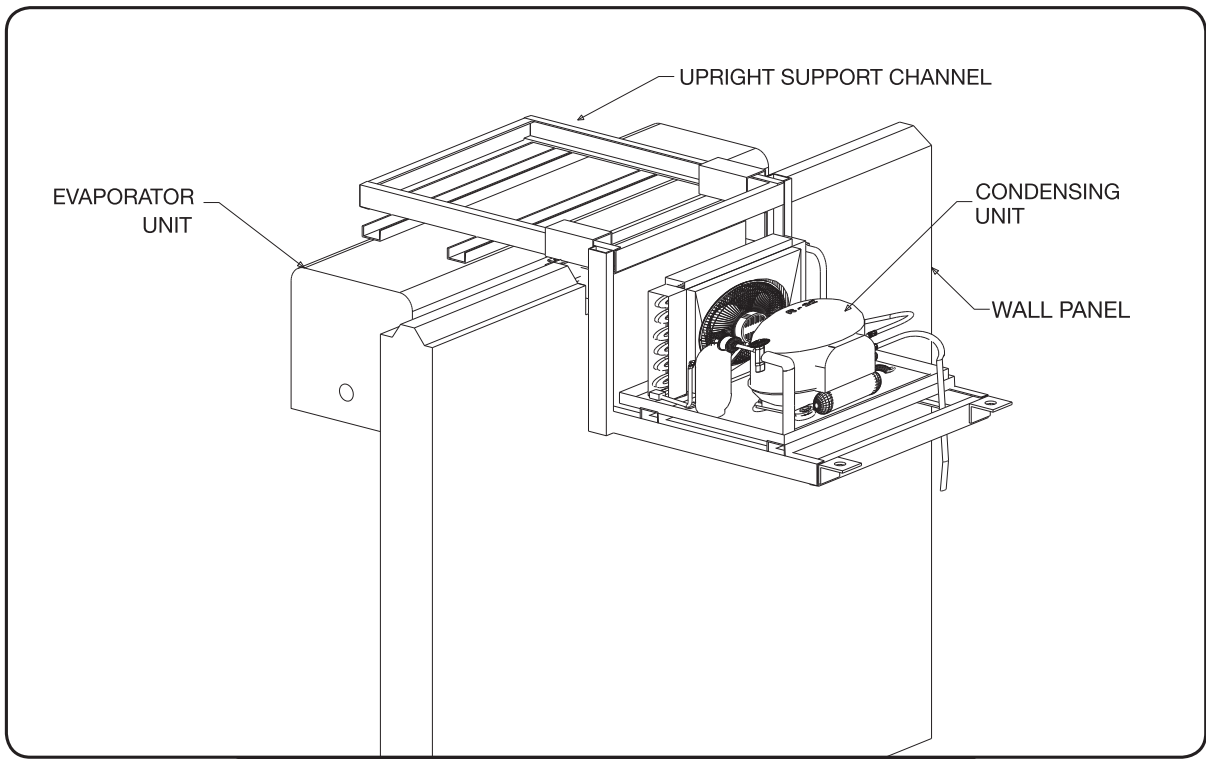
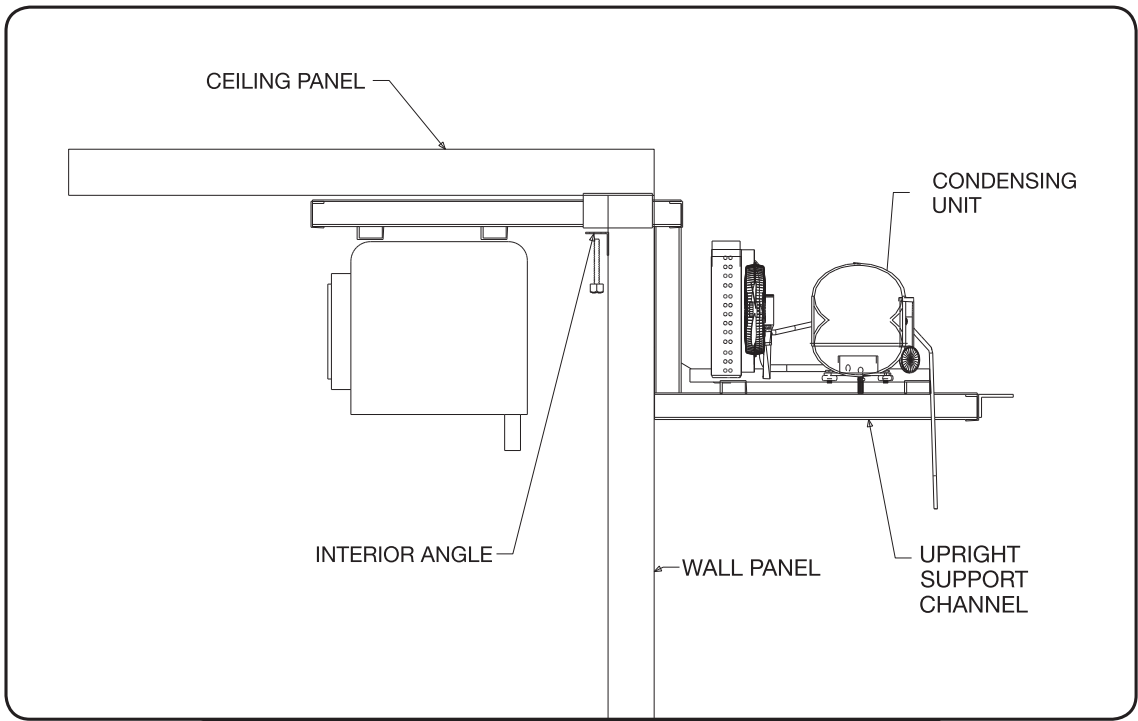

FIG 14. TOP MOUNT STRADDLE UNIT



**FIG 15. SIDE MOUNT STRADDLE UNIT**



**FIG 16. STRADDLE UNIT ON WALL PANEL**

**NOTE : FOR OUTDOOR SELF-CONTAINED UNITS SEE SECTION 7 ON PAGE 31.**

### **2.9.5 Compressor Warranty Card**

The compressor warranty card must be completed in full online. THE WARRANTY WILL BECOME EFFECTIVE UPON RECEIPT BY ARCTIC OF THE FULLY-COMPLETED WARRANTY REGISTRATION ON-LINE FORM.

***REGISTER YOUR WALK-IN ONLINE @ [WWW.ARCTICWALKINS.COM](http://WWW.ARCTICWALKINS.COM)***

### **2.9.6 Dial Thermometer**

The dial thermometer on the door frame may need to be set to reflect accurately interior temperature of the walk-in. To calibrate, pop off the plastic lens using a thin-blade screwdriver in the slots provided. With the same screwdriver in the slot of the thermometer's pointer hub, hold the tail of the pointer with your finger as you gently turn the screwdriver. Recheck the temperature and press the lens back into place.

### **2.9.7 Digital Thermometer**

Digital thermometer with light switch is pre-wired and mounted on the door frame. Instructions are included when alarm system is provided. For any calibration or alarm display issues please visit our website [www.arcticwalkins.com](http://www.arcticwalkins.com)



## SECTION 3: MAINTENANCE

Your walk in was designed and manufactured to offer you many years of trouble-free service. Appropriate maintenance and care will protect your investment and prolong the useful life of your walk-in.

### 3.1 CLEANING

To maintain the appearance of the walls, clean periodically with warm water and a mild soap solution. Dry thoroughly to prevent ice buildup. Do not use caustic or abrasive cleaners. Use only a damp mop to clean floor panels. DO NOT HOSE DOWN OR POUR WATER ON FLOOR PANELS. Panel seams are designed to hold temperature not water.

Under no circumstances should hydrochloric (muriatic) acid be used to clean any part of the walk-in. Damage may result from using this or any other harsh chemicals.

Clean spills immediately! Again, use warm water, mild soap, and dry thoroughly. PERSONAL INJURY MAY RESULT FROM SLIPPERY FLOORS.

Clean door gaskets regularly- use baking soda and warm water and wipe dry with a soft cloth. Be certain that there is sufficient air circulation around the compressor. To prevent overheating, periodically remove grease buildup from the condenser coil and fins.

### 3.2 DOOR HARDWARE

Lubricate hinge pins and sockets with petroleum jelly at least once a year. Periodically check hardware to insure that fasteners are firmly anchored

### 3.3 CEILING STRENGTH

Regular ceiling panels are not designed to support any weight but their own. If it is necessary to put a condensing unit on top of the walk-in, it should not exceed 300 lbs. gross weight and should only be placed as close as possible to a corner or wall panel. Do not store goods atop the walk-in nor permit people to walk on the ceiling panels.

Heavy light fixtures and conduit which are attached only to the interior surface skins of ceiling panels may cause separation of metal from foam. Heavy fixtures such as these should be through-bolted using nylon all-thread rods to minimize transfer and its consequent moisture condensation.

# SECTION 4: SERVICE

## 4.1 DOOR CLOSERS

The door closer has been adjusted at the factory so that the rubber roller just touches and slightly turns as it passes the tip of the hook when the door is closing (Fig. 17). When properly installed, the door is self-closing and should not be slammed. Slamming the door may cause the door closer to fall out of alignment.

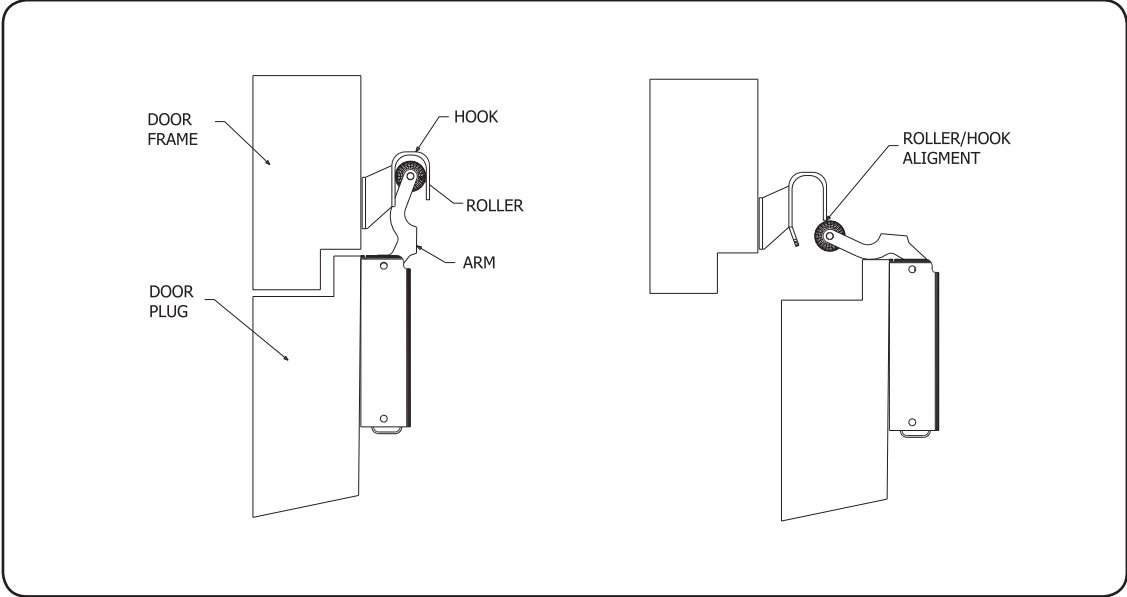

**FIG 17. DOOR CLOSER**

Any readjustment of the door closer can be accomplished by the addition of washers under the top fastening screws, in order to lower the hook. Washers installed under the lower screws will raise the hook. (Fig 18)

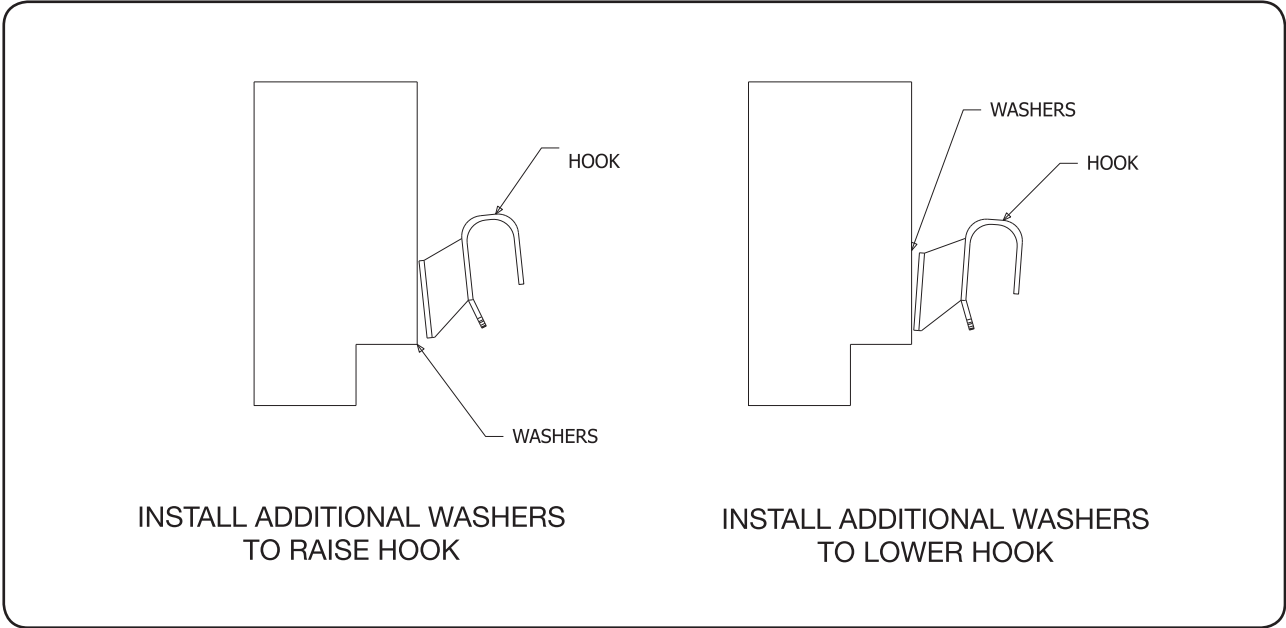

**FIG 18. RE-ADJUSTMENT OF DOOR CLOSER**

## 4.2 DOOR HEATER REPLACEMENT

1. The door heater is connected to the same power supply as the light fixture. **TURN POWER OFF AT THE SOURCE!**
2. Remove threshold.
3. Using a thin-blade screwdriver apply pressure (not leverage) to the door frame extrusion as shown in Fig 19. 1. Pull the s/s snap-on cover with your hand as shown. Always start at the end as indicated in Fig.19.2 and continue the operation described above until the entire cover is removed.
4. Remove globe from the vapor proof light fixture.
5. Remove receptacle plate on VP light and disconnect heater wire leads.
6. Remove defective heater wire.
7. Install replacement heater wire. Tack with permagum sparingly in order to hold wire in place in its channel.
8. Reinforce with aluminum foil tape (two wraps) at four corners.
9. "Snake" heater wire at threshold taking extra care not to overlap wire, or allow wire to touch itself. Tack down with permagum and foil tape.
10. Reconnect heater wire leads on VP light.
11. Re-Install receptacle plate, globe on VP light.
12. To replace the s/s cover, apply pressure as shown in Fig. 19.1 and with your hand press down until the cover snaps in place.
13. Re-install threshold.
14. Turn power supply on.

**NOTE: A THERMODISC IN THE WIRE CIRCUIT WILL KEEP THE WIRE FROM TURNING ON UNTIL THE INSIDE TEMPERATURE GETS DOWN TO ABOUT 40 DEGREES.**

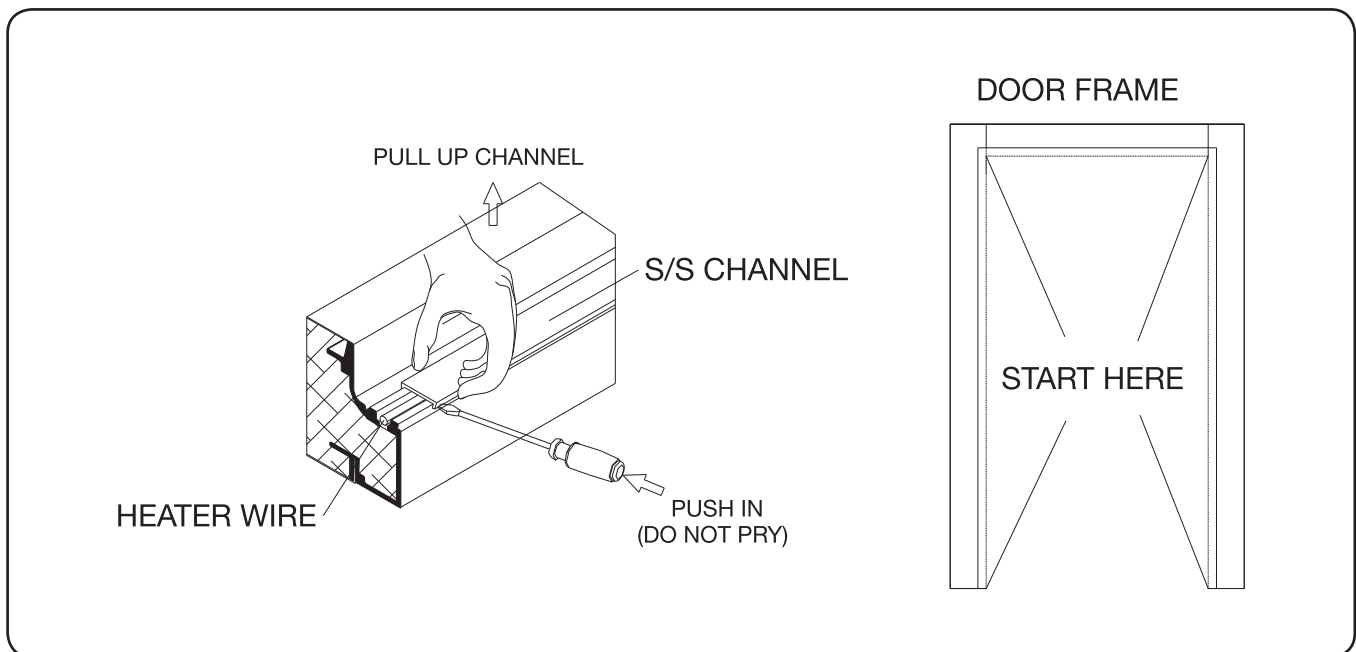

FIG 19.1

FIG 19.2

### 4.3 DOOR SWEEP REPLACEMENT

1. To remove the door open it past 90 degrees and carefully lift it off the nylon hinge pins. Note the position of the cam faces on the pins- they must be in proper position- so that door will self-close.
2. Place door on a flat surface, face down.
3. To install new sweep by pushing the dart into the groove in the channel. The interior sweep should be at least as wide as the door opening. The length of the exterior sweep should be the same as the width of the door face. Make relief cut-outs at the end of each exterior sweep where it overlaps the magnetic gasket. (See fig.19.3) Replace screws removed.
5. Reverse the procedure in Step 1 to reinstall door. Be certain that the nylon cams are in the same position they were in when the door was removed.  
When properly positioned, the nylon cams will lower the door as it closes, and raise the door as it opens.
6. Be sure that your building floor under the door swing radius is free of any protrusions or sharp objects which may damage the sweep.

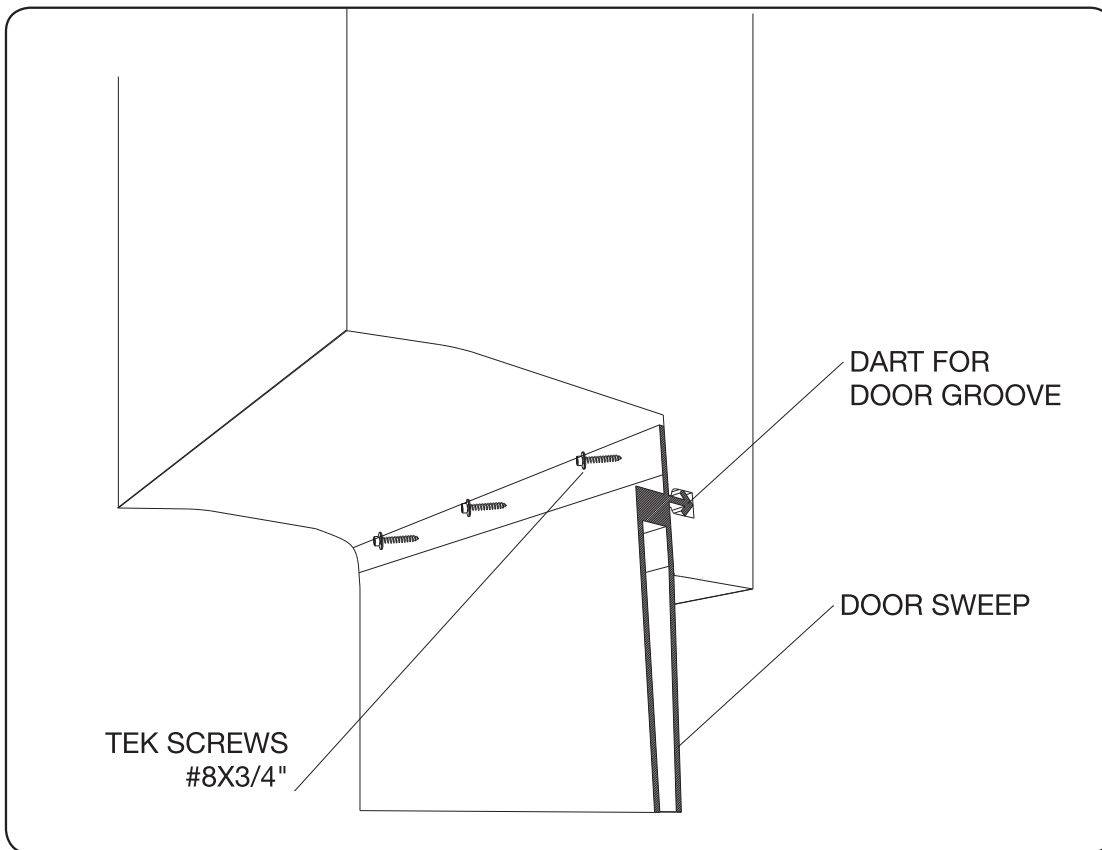

FIG 19.3 DOOR SWEEP REPLACEMENT

## 4.4 MAGNETIC GASKET REPLACEMENT

1. The door gasket snaps into a narrow channel inside the door's edge and can be removed by pulling it upward starting at the bottom of the door.
2. The new gasket is installed by pushing its dart into the door groove starting at one upper corner. Be sure that the gasket is the right size before attempting to install it.

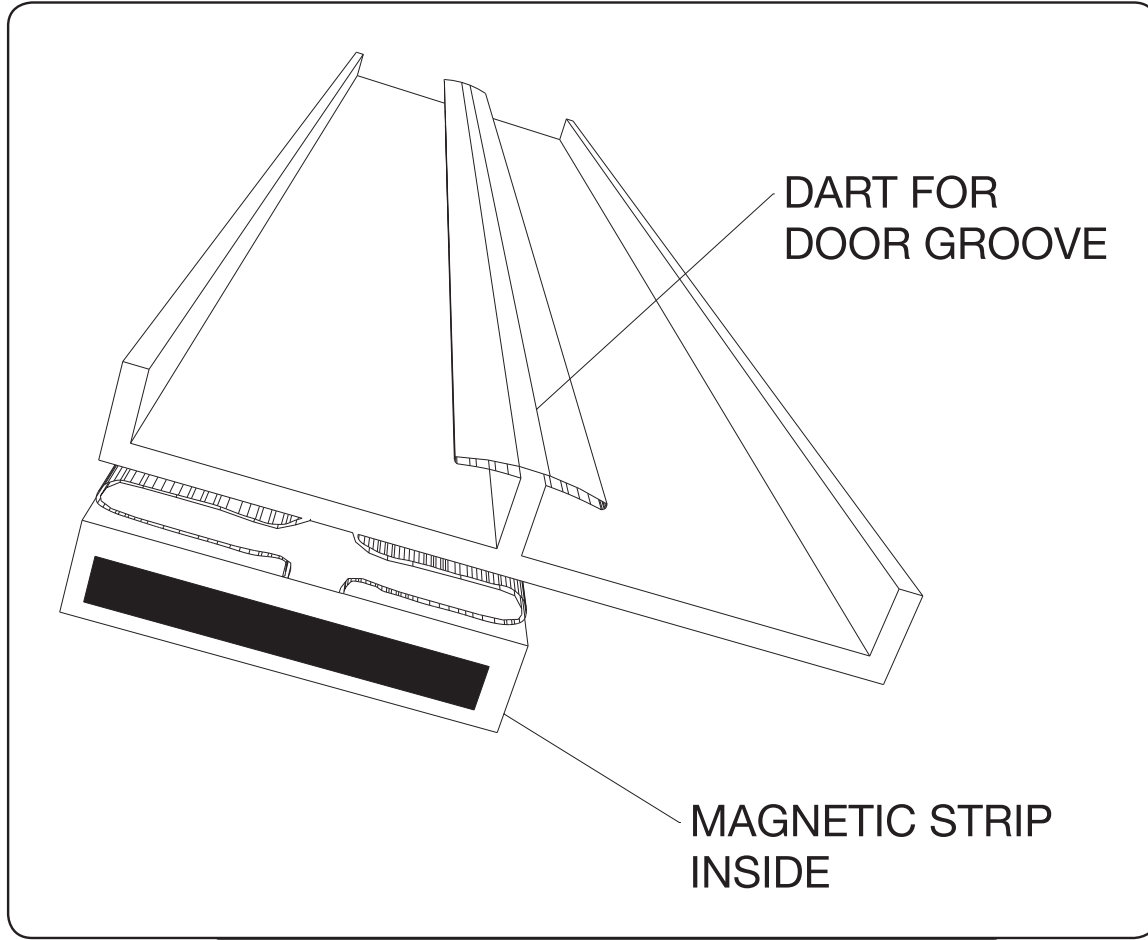

FIG 20. MAGNETIC GASKET REPLACEMENT

## 4.5 THERMOSTAT ADJUSTMENTS

Should temperature requirements change, the thermostat range may be adjusted by means of the screw on the face of the thermostat which is reached through an opening case. Turning clockwise will decrease temperature, counterclockwise increases it; **NOTE:** Some thermostats are provided with an exterior adjusting knob and some may require removal of the case by loosening the screw at the bottom. In all cases, turning the screw or knob in the center of the temperature dial rotates the dial against the pointer. It should not be necessary to adjust the differential which should remain at approximately 5 degrees.

**CAUTION:** Do not set a cooler thermostat below the walk-ins design temperature or product freezing or excessive evaporator coil icing may result. Always have a competent refrigeration technician make any critical adjustments made necessary by changing conditions as mentioned in Section 2.9.4.

# SECTION 5: ELECTRICAL SCHEMATICS

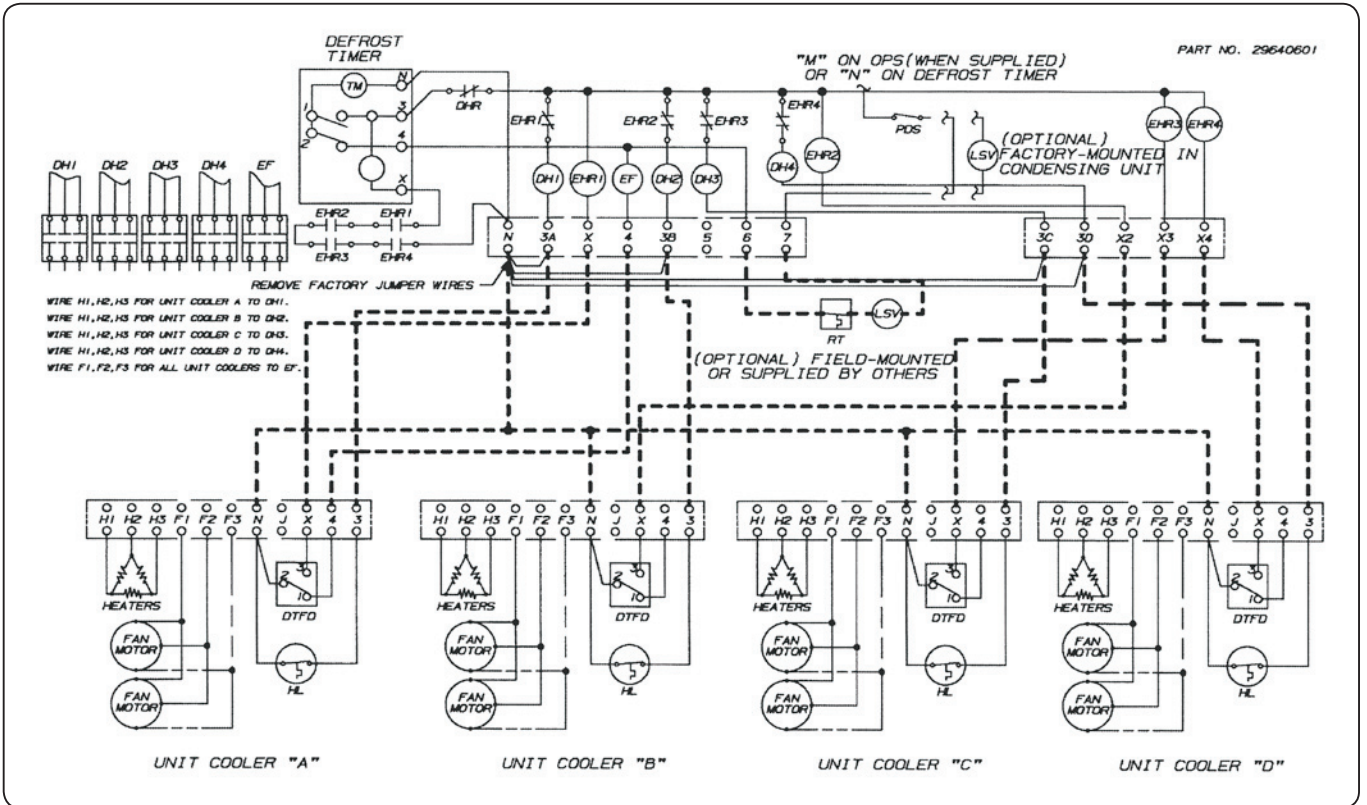

Diagram 1 - Typical Wiring Diagram for Defrost Contractor with Evaporator Holdout with Heater Limit

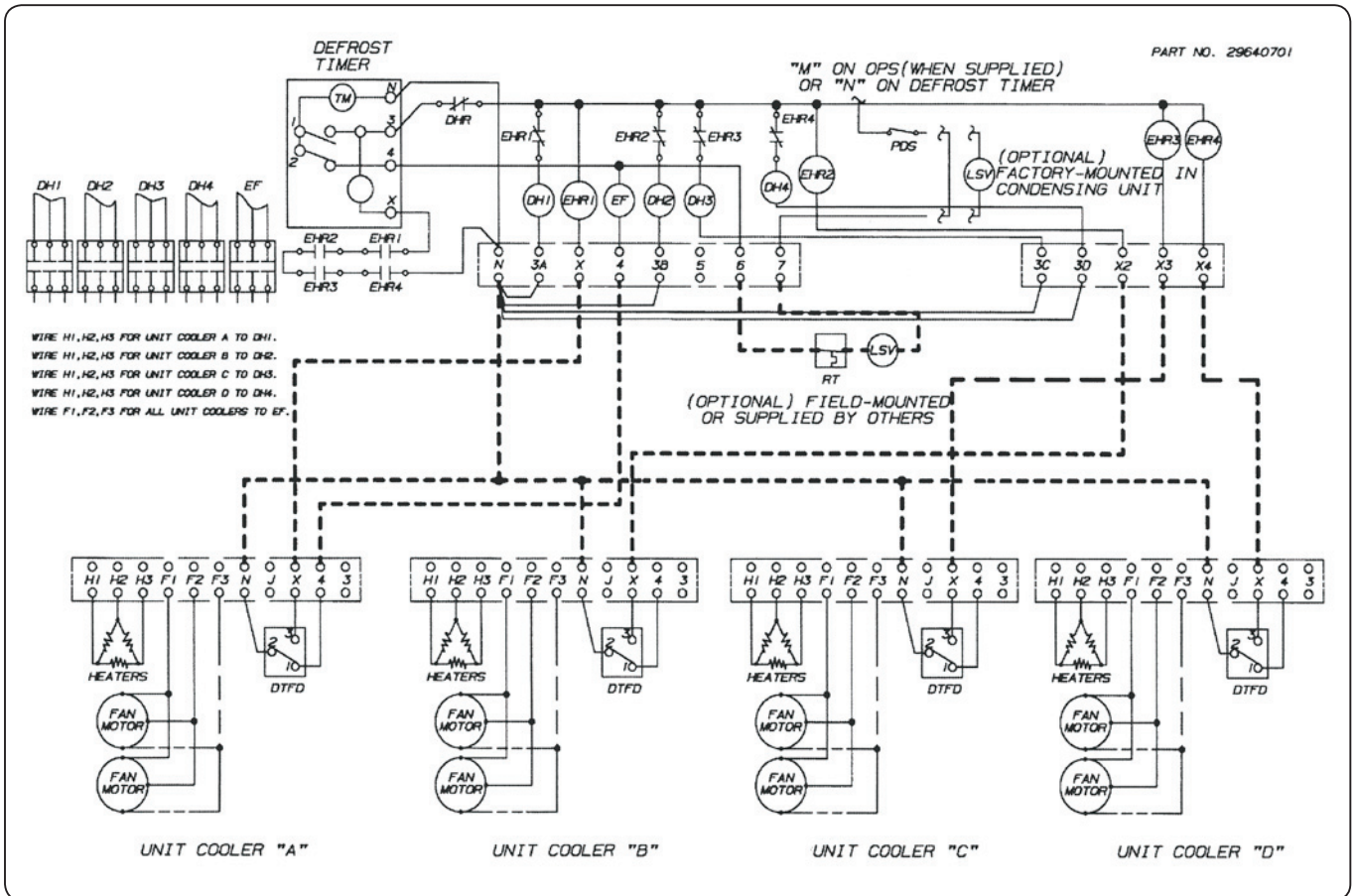
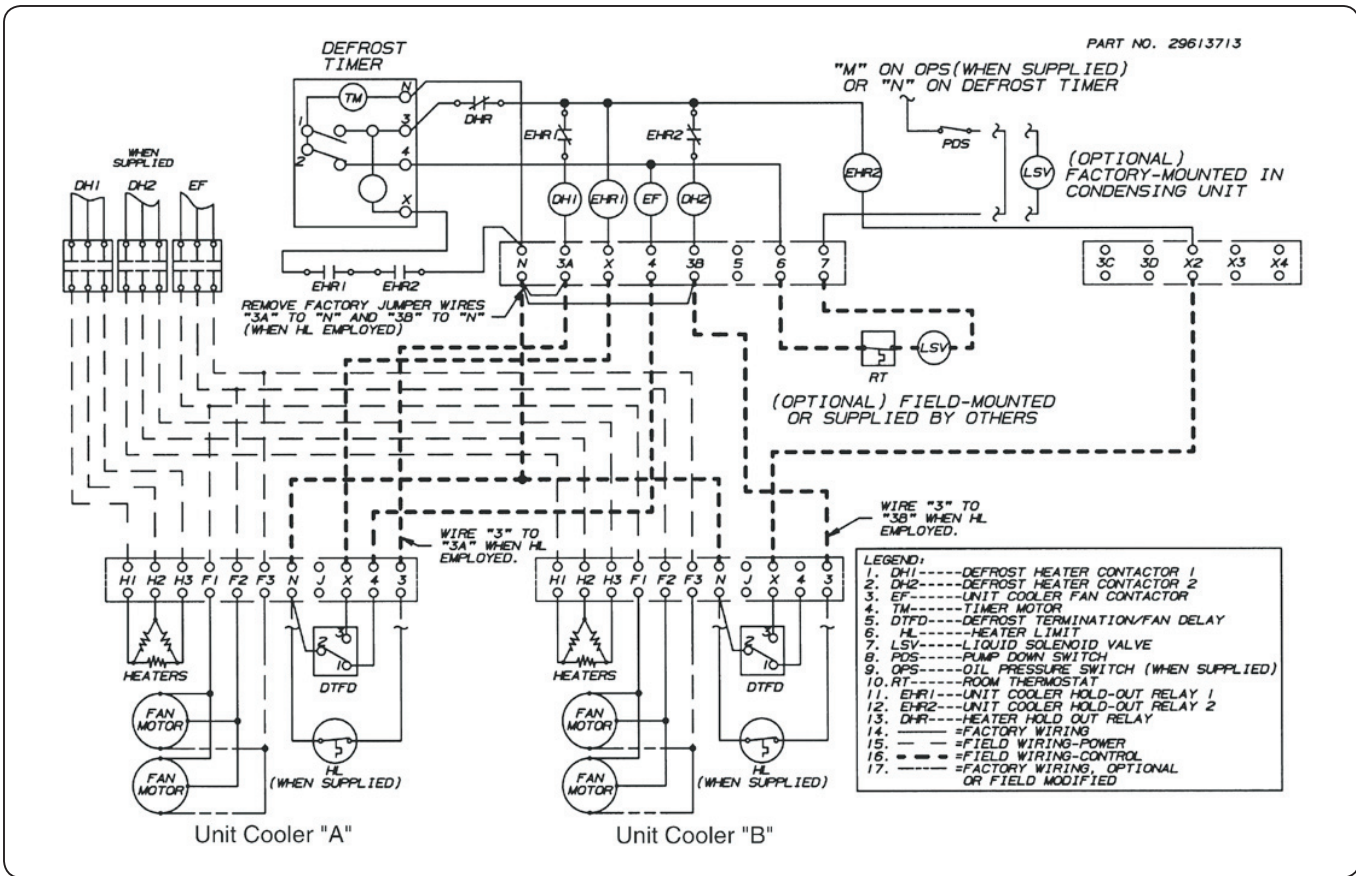
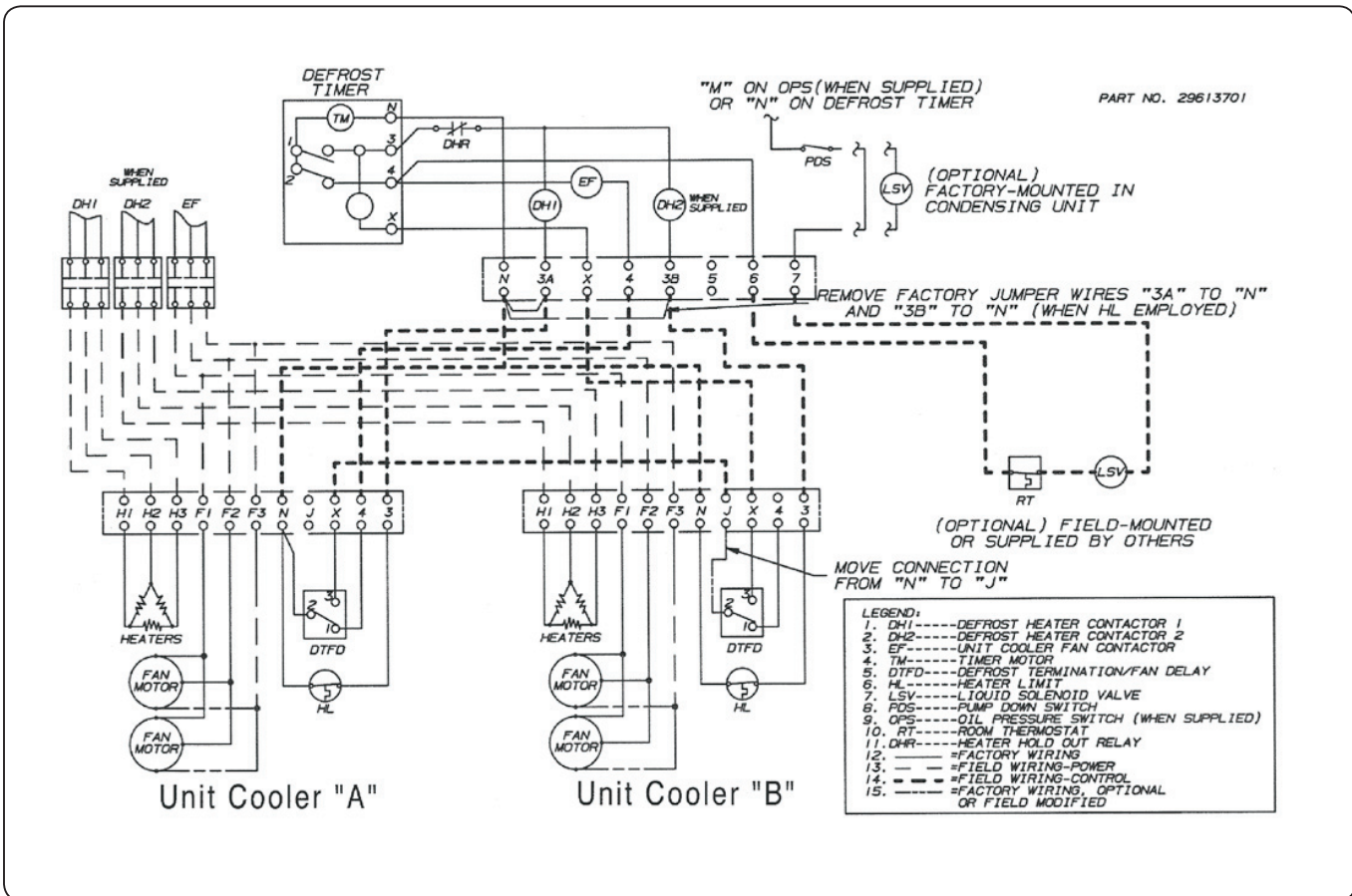

Diagram 2 - Typical Wiring Diagram for Defrost Contractor with Evaporator Holdour Relay without Heater Limit

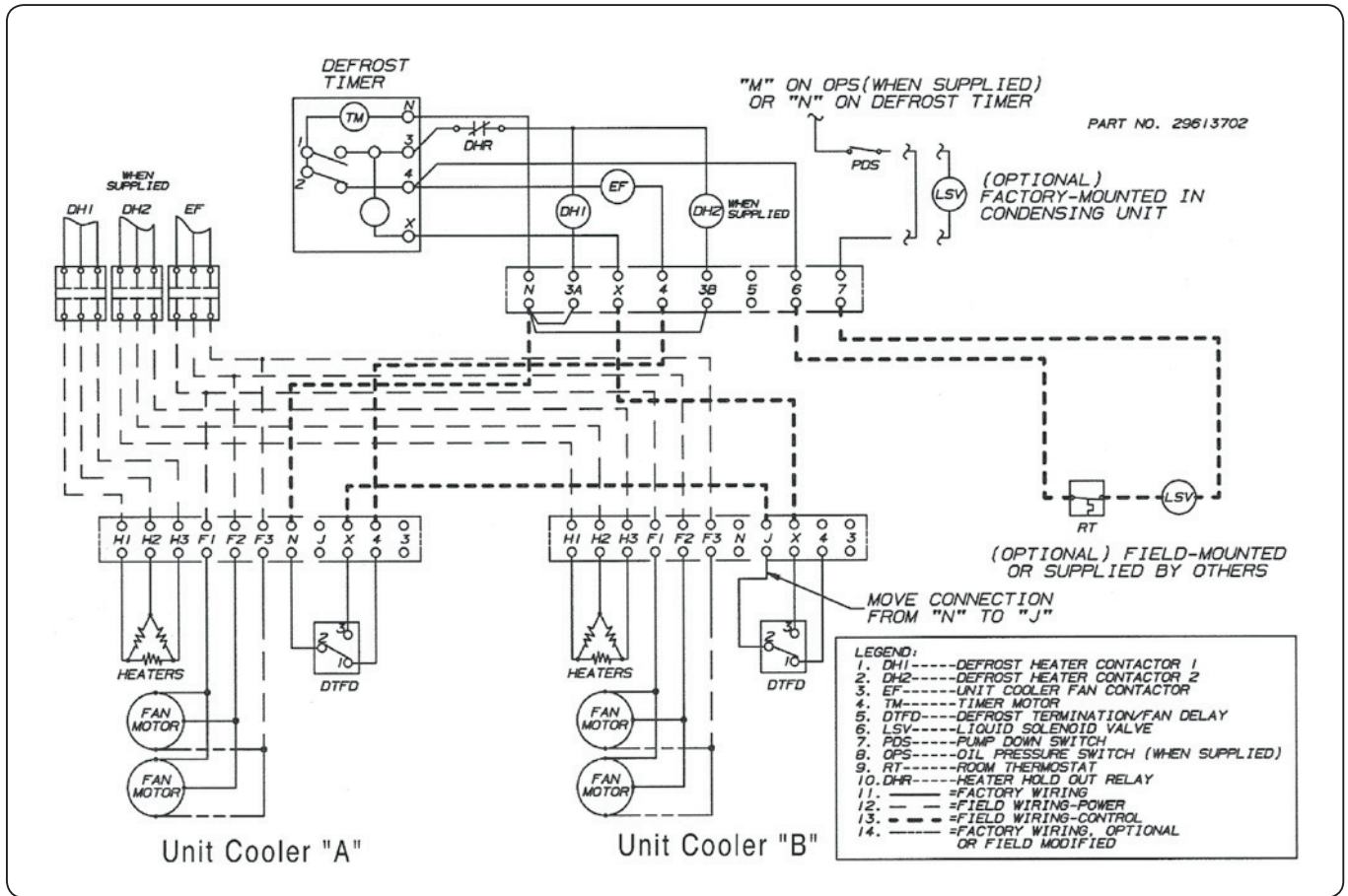



**Diagram 3 - Typical Wiring Diagram for Multiple Evaporators Defrost and Evaporator Fan Contractors with Unit Cooler Holdout Relay.**



**Diagram 4 - Typical Wiring Diagram for Multiple Evaporators with Heater Limit Defrost and Evaporator Fan Contractors.**



**Diagram 5 - Typical Wiring Diagram for Multiple Evaporators with Evaporator Fan Contractors but without Heater Limit Defrost**

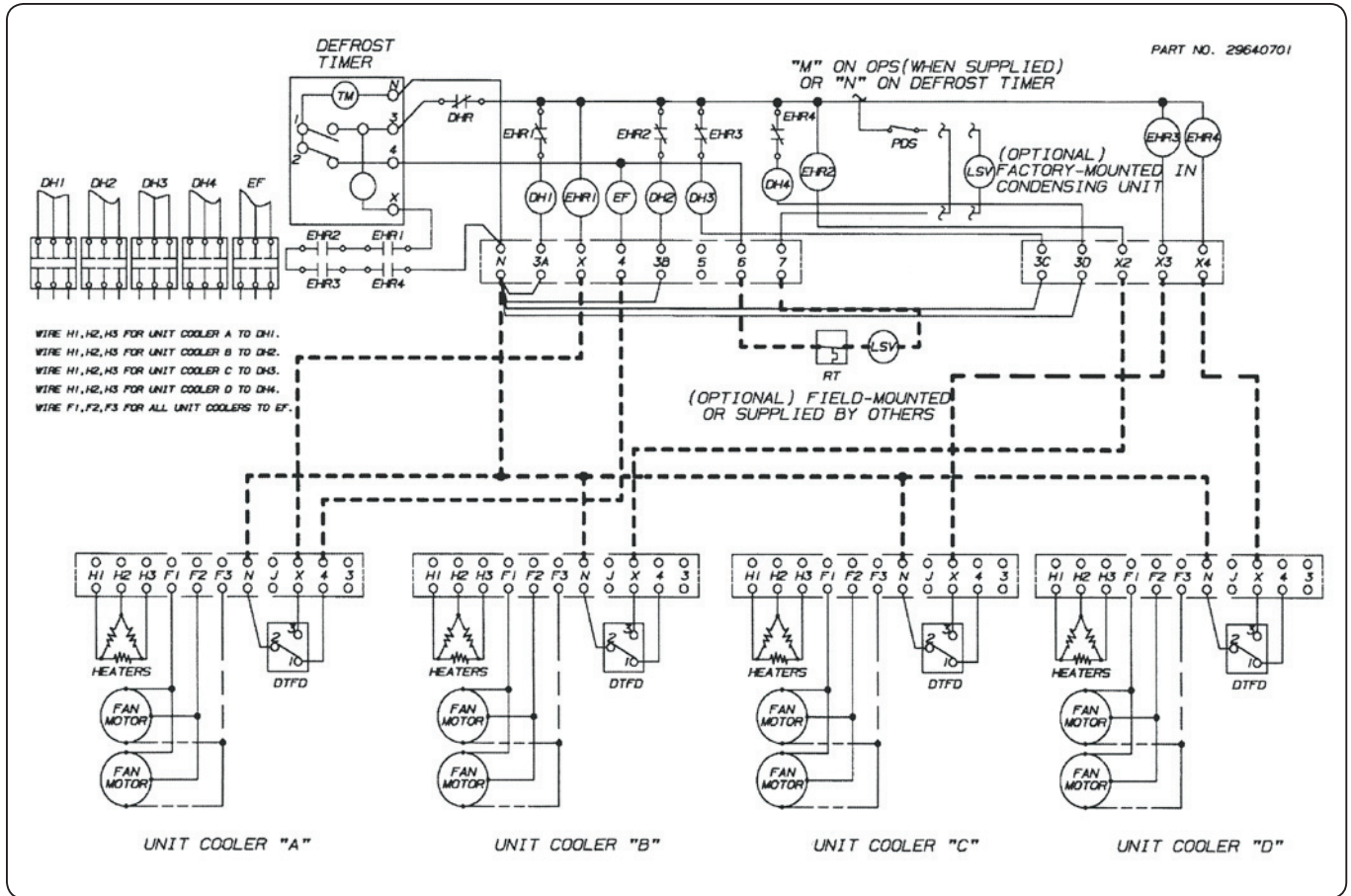

**Diagram 6 - Typical Wiring Diagram for Single Evaporator Defrost and Evaporator Fan Contractors**



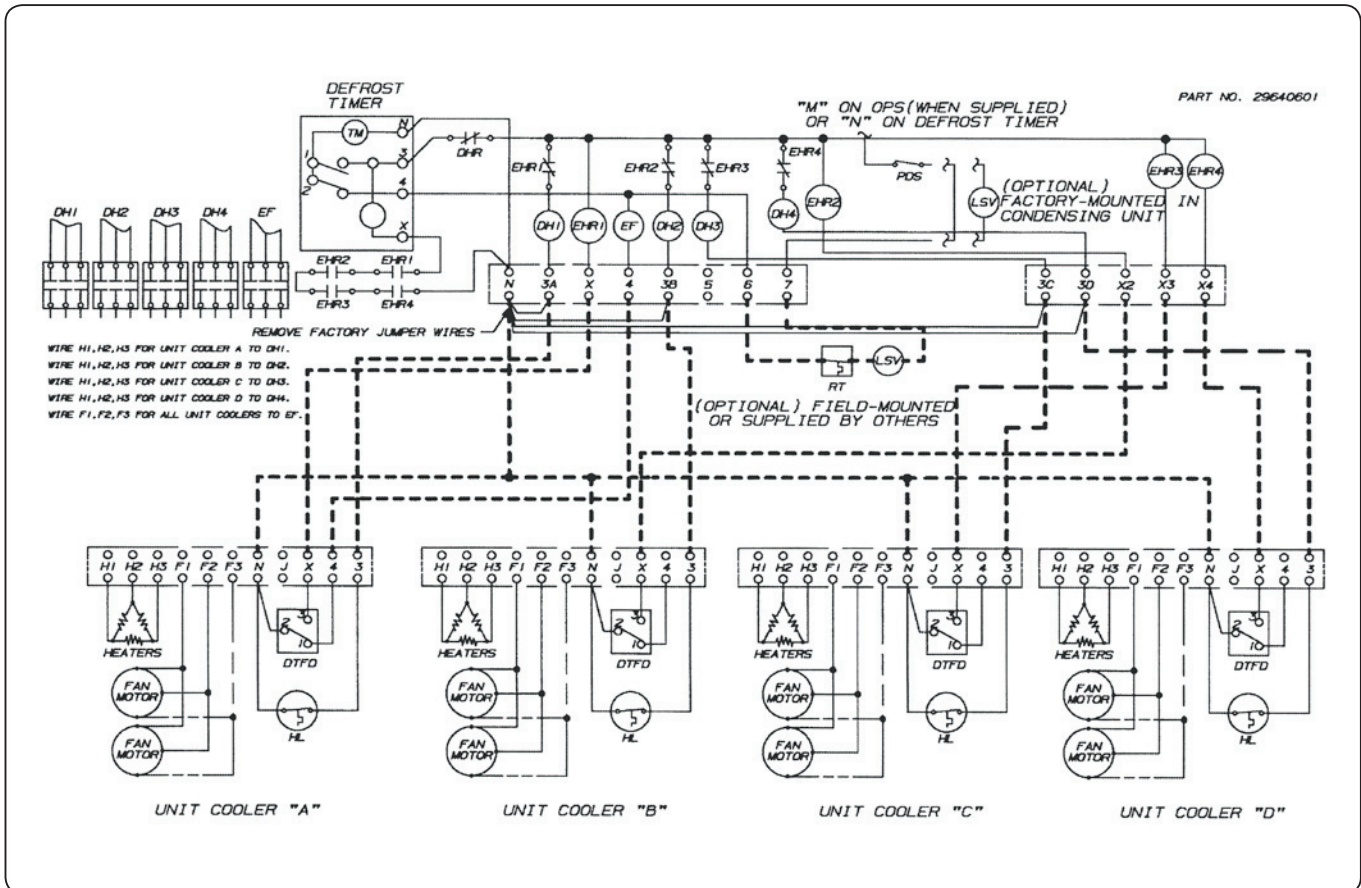

Diagram 7 - Typical Wiring Diagram for Single Evaporator/ Single Phase Defrost and Evaporator Fan Contactors.

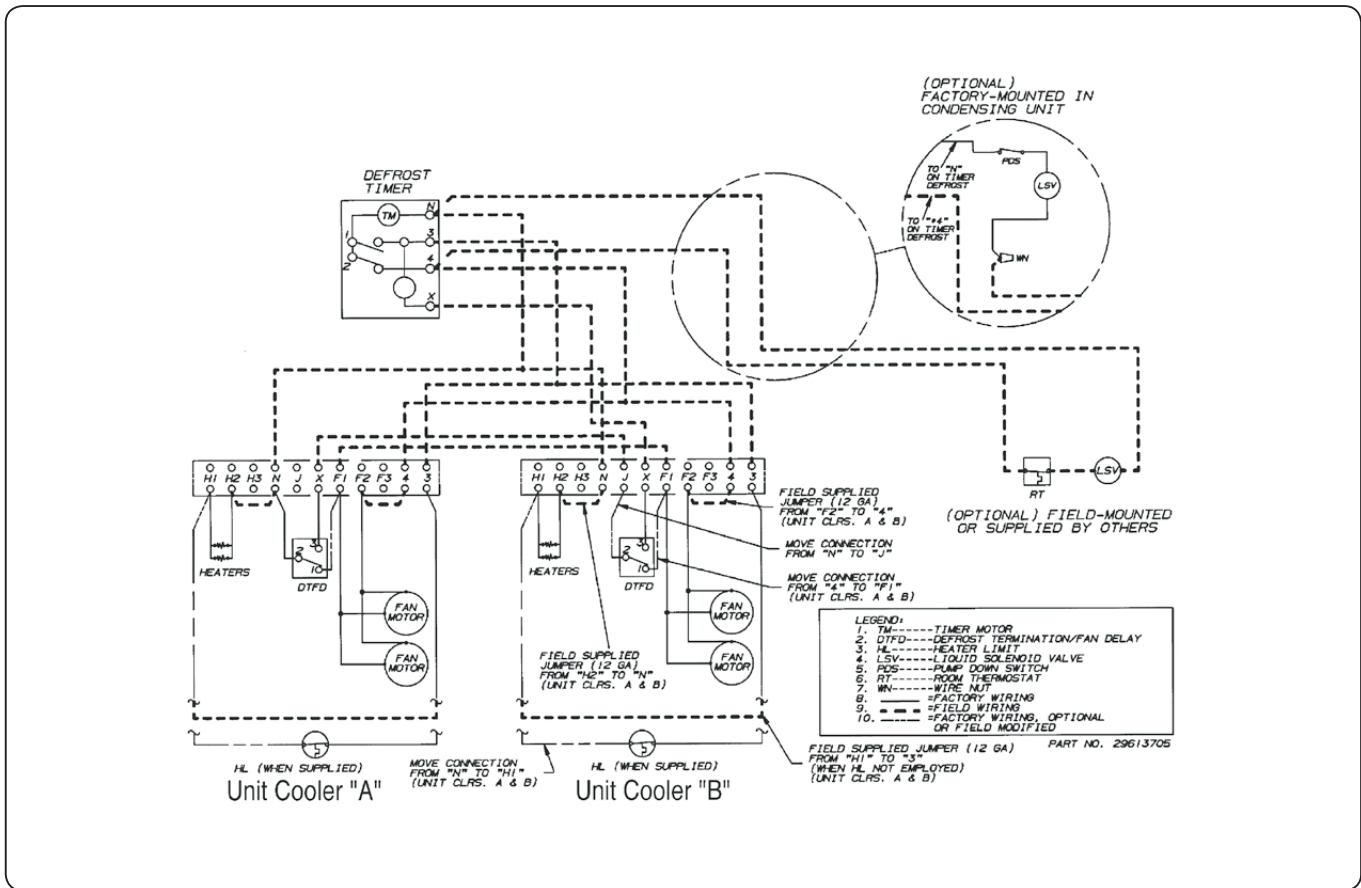

Diagram 8 - Typical Wiring Diagram for Multiple Evaporators with Defrost Timer Only

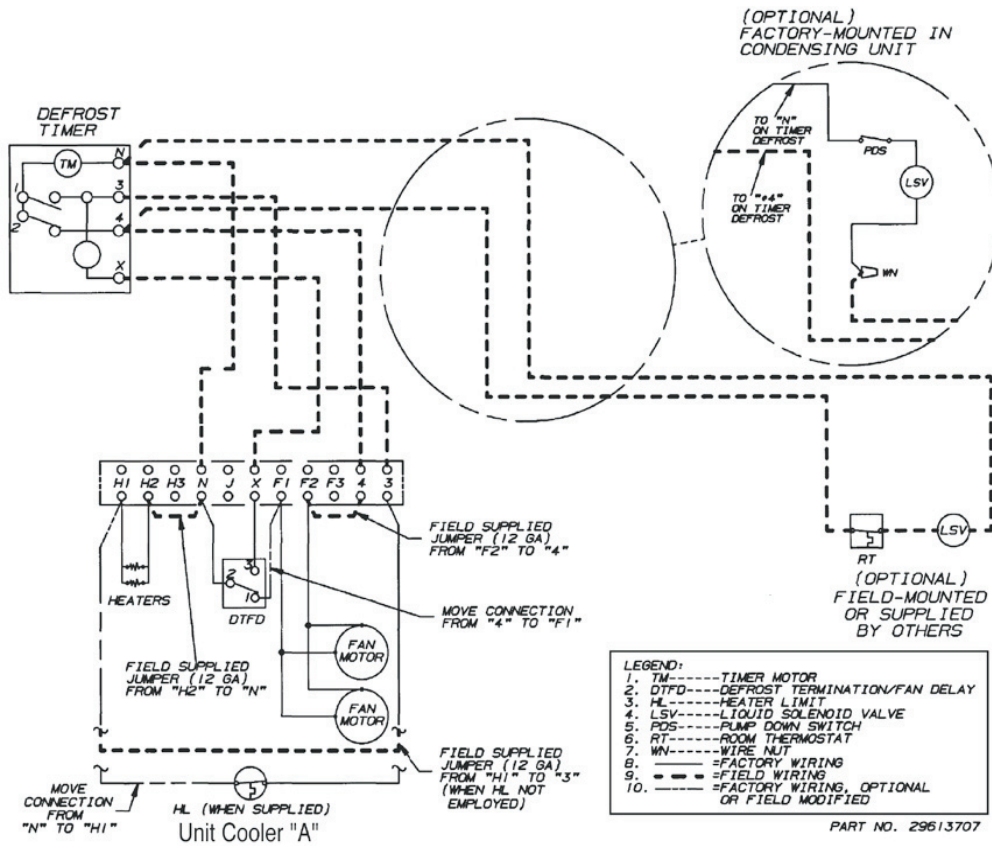

Diagram 9 - Typical Wiring Diagram for Single with Defrost Timer Only

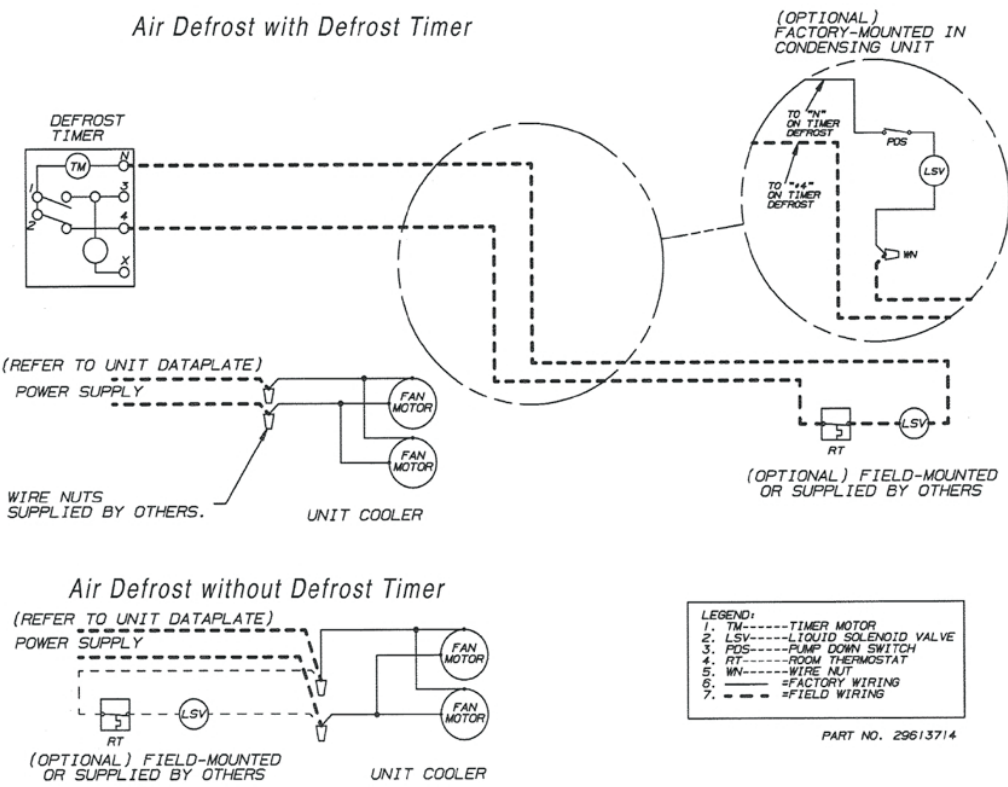

Diagram 10-Typical wiring Diagram for Single Evaporator with and without Defrost Timer

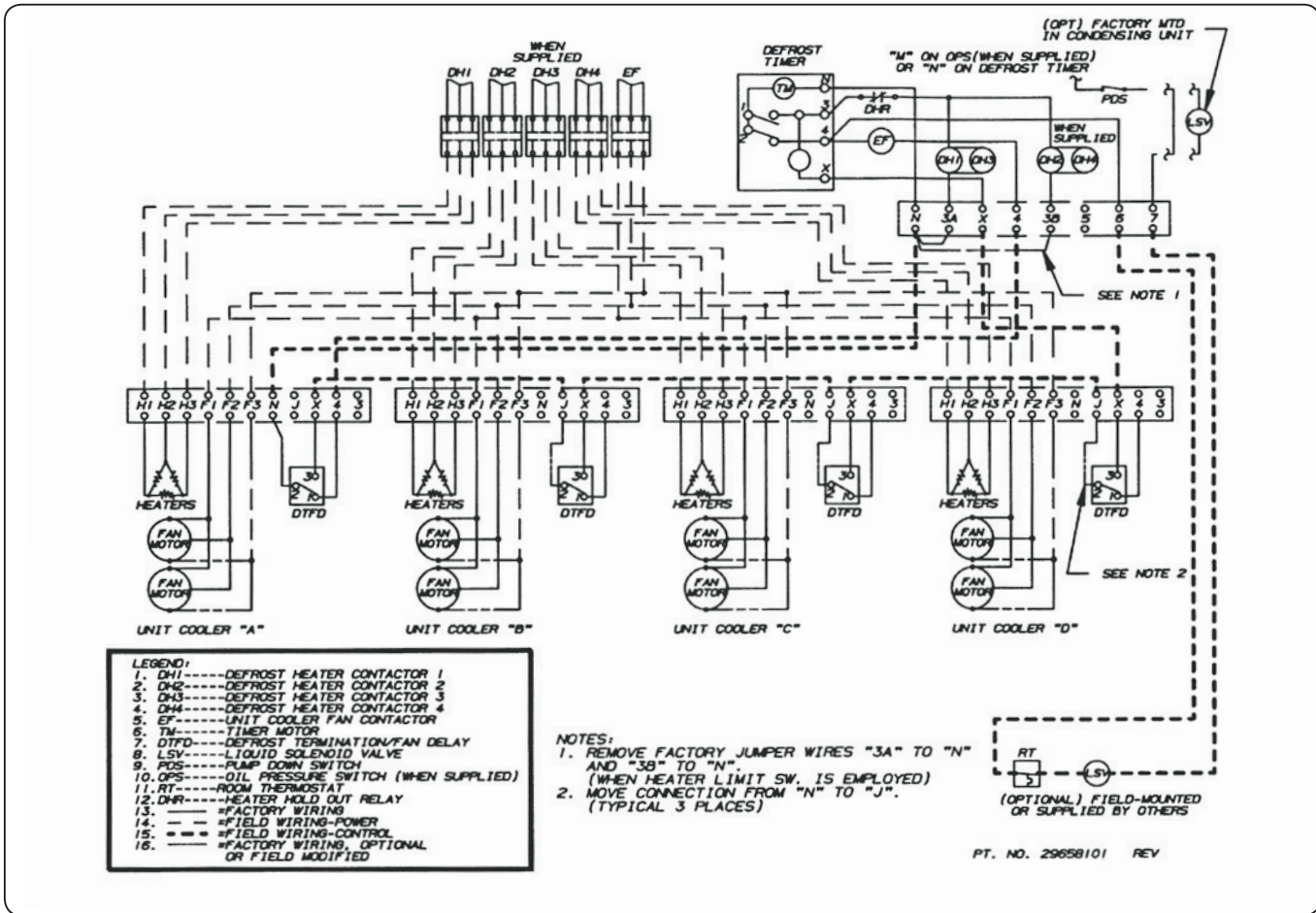

Diagram 11 - Typical Wiring Diagram for Multiple Evaporators with Defrost Switches Connected in Series and without Holdout Relays/ Heater Limits

## SECTION 6: PARTS POLICY/MINIMUM ORDERS

All parts orders are shipped via UPS. Provide your job/serial/invoice number when ordering. The minimum order amount is \$25.00. All parts orders are prepaid with credit cards accepted.

### 6.1 MOST COMMONLY ORDERED REPLACEMENT PARTS

PART NUMBER	DESCRIPTION
1039	4" NSF floor screed
3036	Magnetic door gasket for 34" x 78" door opening (eff. 5/96)
3103	Magnetic door gasket for 34" x 78" door opening (Before. 5/96)
3051	Door closer for flushmount door
3065	Door Handle (Before 8/97)
3070	Door Handle (eff. 8/97)
3066	Flush mount door hinges
3031	Nylon Inserts
3022	Spring Conversion Kit
1041	Door sweep assembly (any size)
6000	Heater wire 34" x 78" door opening
6001	Heater wire 34" x 78" door opening
3098	Stainless steel channel (any size)
4093	Thermodisc
3090	Strip Curtains 40" x 80"
4089	Flourescent light fixture

# SECTION 7:SELF-CONTAINED REFRIGERATION

## OUTDOOR SELF CONTAINED REFRIGERATION UNITS

1. Curb material shall be fastened securely to the box ceiling by bolting through with carriage bolts (provided).
2. The membrane roof cover shall be fastened to the box covering the curb. After the roof cover is in place, open a hole on the roof cover where the evaporator is going to be (25' x 38' size) over lapping the membrane by an inch, secure it to the curb.
3. Secure the unit to the roof curb. Seal screw heads as necessary to prevent moisture from entering beneath membrane.

### SELF CONTAINED OUTDOOR INSTALLATION:

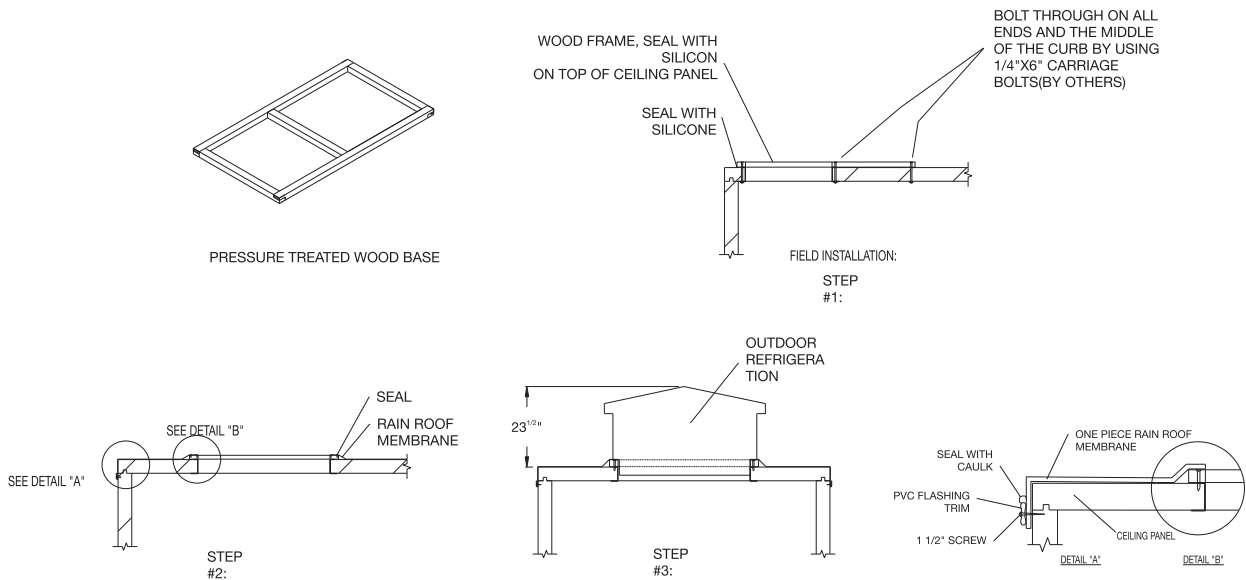

FIG.21:OUTDOOR SELF-CONTAINED UNIT INSTALLATION



## SECTION 7: WARRANTY REPLACEMENT

See warranty policy below. In the event of any problem not covered by these instructions or any perceived defect in material or equipment, please consult our factory or an authorized sales representative. Arctic will not accept responsibility for the payment of work performed without prior authorization from the factory.

Parts and compressor under warranty are to be replaced only. In the event that they must be field purchased, Arctic will allow only their factory cost. Consult our customer service department referring to walk-ins job/serial/invoice number in any communication.

### **IMPORTANT WARRANTY INFORMATION**

THE REFRIGERATION SYSTEMS SUPPLIED BY ARCTIC INDUSTRIES ARE COVERED BY THREE WARRANTIES.

TO ACTIVATE THESE WARRANTIES YOU MUST FILL OUT THE WARRANTY CARD. THE REGISTRATION CARD IS ONLINE: [WWW.ARCTICWALKINS.COM/WARRANTY](http://WWW.ARCTICWALKINS.COM/WARRANTY). YOUR WARRANTY IS NOT VALID UNTIL YOU DO.

YOUR SERVICE TECHNICIAN IS REQUIRED TO CALL THE ARCTIC INDUSTRIES CUSTOMER-SERVICE DEPARTMENT PRIOR TO ANY WARRANTY WORK BEING PERFORMED.

IF EMERGENCY SERVICE MUST BE PERFORMED AFTER ARCTIC BUSINESS HOURS, SEND A REASONABLE BILL FOR THE WORK PERFORMED AND ARCTIC WILL REIMBURSE YOU FOR THE WHOLESALE COST OF PARTS AND THE LABOR ON A STRAIGHT TIME BASIS ACCORDING TO THE TERMS OF THE WARRANTY.

#### **1) ONE YEAR REFRIGERATION LABOR WARRANTY:**

THIS WARRANTY WILL PAY FOR THE STRAIGHT TIME LABOR TO REPAIR OR REPLACE DEFECTIVE PARTS ORIGINALLY SUPPLIED BY ARCTIC FOR A PERIOD OF ONE YEAR. SERVICE WORK MUST BE PERFORMED BY A LICENSED REFRIGERATION CONTRACTOR.

#### **2) ONE YEAR PARTS WARRANTY:**

THIS WARRANTY WILL REPLACE FROM FACTORY INVENTORY OR REIMBURSE FOR REPLACEMENT IN THE FIELD, AT ARCTIC WHOLESALE COST, AT ARCTIC'S OPTION, ANY PART THAT PROVES DEFECTIVE. ALL PARTS MUST BE RETURNED TO ARCTIC FOR EVALUATION. ALL RETURNS MUST HAVE PRIOR RETURN AUTHORIZATION FROM ARCTIC.

#### **3) FIVE YEAR LIMITED COMPRESSOR WARRANTY:**

THIS WARRANTY WILL PAY THE COST TO REPLACE THE ACTUAL COMPRESSOR, LESS LABOR FOR A FIVE YEAR PERIOD. THE LABOR COSTS ARE COVERED DURING THE FIRST YEAR ONLY UNDER THE TERMS OF THE ONE YEAR LABOR WARRANTY.

ARCTIC WARRANTIES DO NOT COVER REFRIGERATION LINES PROVIDED BY YOUR INSTALLER, CONDENSATE LINES PROVIDED BY YOUR PLUMBER OR ELECTRICAL LINES/AND/OR CONNECTIONS PROVIDED BY YOUR ELECTRICIAN.

MINOR ADJUSTMENTS, STANDARD MAINTENANCE, DIAGNOSTICS, REFRIGERANT, TORCH CHARGES, SILVER SOLDER, OR TAXES ARE NOT COVERED. TRAVEL RELATED COSTS ARE LIMITED TO \$35.00 READ YOUR WARRANTY STATEMENT CAREFULLY.

ARCTIC CUSTOMER SERVICE (800) 325-0123 EXTENSION 716

## **One Year Original Equipment Parts Warranty**

Arctic Industries warrants to original purchaser/user at the location where originally installed, for the period of one year the repair or replacement of defective parts at Arctic's option.

This warranty is limited to the repair or replacement of any warranted part, that upon return with Arctic's authorization, and in the judgment of Arctic Industries, proves to be defective.

This warranty applies to all refrigeration, parts, walk-in panels and door parts, originally supplied by Arctic Industries.

This warranty is expressly in lieu of any other warranties, expressed or implied, including any implied warranty of merchantability or fitness for particular purpose and of all of the liabilities and obligations, on Arctic's part. Under no circumstances shall Arctic be liable to the purchaser or any other party for any special or consequential damages. This warranty is for all parts supplied by Arctic, and applies only in the continental United States, Virgin Islands or Puerto Rico.

## **One Year Refrigeration Labor Warranty**

Arctic warrants the original purchase-user at the location where originally installed the reasonable costs, straight time only, associate with the labor portion of the service bill for a one year period from the installation date.

This warranty only applies to the labor associated with the repair or replacement of defective warranted parts on the refrigeration systems supplied by Arctic Industries. The labor cost is paid for or reimbursed by Arctic only after the defective parts are returned to Arctic, with a return authorization, freight pre-paid, and then following an inspection by Arctic Industries are found to be defective.

This warranty applies to all refrigeration systems supplied by Arctic Industries. This warranty does not include field wiring and plumbing. Refrigeration lines not supplied by or contracted for by Arctic, minor service adjustments, maintenance, diagnostics, refrigerant, torch charges, silver solder, or taxes are also excluded. Travel related costs are limited to \$35.00.

This warranty is expressly in lieu of any other warranties, expressed or implied, including any implied warranty of merchantability or fitness for a particular purpose and of all of the liabilities and obligations, on Arctic's part. Under no circumstances shall Arctic be liable to the purchaser or any other party for any special or consequential damages.

This warranty is for refrigeration supplied by Arctic, and applies only to the continental United States, Virgin Islands and Puerto Rico.

## **Five Year Limited Compressor Warranty**

ARCTIC warrants to the original purchaser-user at the location where originally installed, the compressor herein defined to be free from defects in material and factory workmanship. For a period of five (5) years from the date of sale, and if the unit were properly installed, operated, and maintained under normal conditions, ARCTIC agrees to repair or replace at its option, with similar part or parts, any part or parts of said compressor proved to the satisfaction of the Warrantor to have been defective at time of sale. The maximum liability of the Warrantor for any one replacement or repair shall be limited to the payment of the Warrantors sale price to dealers in effect at the time the Warranty is issued. All replacement compressors shall be protected by the installation of a new liquid and suction drier.

ARCTIC further agrees to extend without charge, for the balance of the above specified Warranty period, similar or like coverage for one (1) additional new or repaired compressor, provided the repair or replacement of the original compressor was made under the terms of this Warranty. The compressor herein warranted shall mean the compressor housing, the motor power unit which drives the compressor, including the compressing mechanism enclosed in said housing, but excludes all external electrical components. This Warranty shall be void if the compressor identified herein is installed or operated contrary to the manufacturer's instructions, or if identification or serial numbers have been altered, defaced or removed.

This Warranty does not apply to damage to said compressor in transit after sale, nor to damage caused by unauthorized alterations, fire, accidents, lightning, misuse or abuse, or by any cause other than defects in factory workmanship and materials, nor to any damage or loss of any refrigerant, including any products or property then stored or located within the area being cooled; nor to loss of profits or income due to any malfunctioning of the warranted compressor. The Warrantor does not assume any liability or costs of labor, freight, or other incidental costs, or for any expenses incurred due to short or reduced supply. Any warranty replacement will be made F.O.B. ARCTIC.

This Warranty is not assignable except only with the prior written consent of the Warrantor. All materials replaced under this Warranty becomes the property of the Warrantor.

ALL OTHER REFRIGERATION EQUIPMENT SOLD BY ARCTIC CARRIES A ONE YEAR WARRANTY MADE BY THE MANUFACTURER AND IS NOT WARRANTED IN ANY RESPECT BY ARCTIC.

THIS WARRANTY IS EXPRESSLY IMPLIED IN LIEU OF ANY OTHER WARRANTIES, EXPRESSED OR IMPLIED, INCLUDING ANY IMPLIED WARRANTY OF MERCHANTABILITY OR FITNESS FOR A PARTICULAR PURPOSE AND OF ALL OTHER LIABILITIES OR OBLIGATIONS WHATSOEVER, ON ARCTIC'S PART, UNDER NO CIRCUMSTANCES, WHATEVER, SHALL ARCTIC BE LIABLE TO THE PURCHASER OR ANY OTHER PARTY FOR ANY SPECIAL OR CONSEQUENTIAL DAMAGES.

### **Fifteen Year Panel Warranty**

ARCTIC warrants to the original purchaser-user, that the walk-in refrigerated rooms and other prefabricated insulated boxes, panels or doors manufactured by the company are free from any defect in material or workmanship under the conditions of normal use and service, provided that it remains in the location where originally installed. The Company's obligation under this warranty shall be limited to repairing or replacing at our option, FOB factory, any of the covered parts of said walk-in which proved defective within fifteen (15) years from the date of original installation. All materials replaced under this warranty become the property of the warrantor.

This warranty does not apply to equipment which has been subject to any accident, fire, negligence, alteration, damage in transit, abuse, misuse, or improper installation. This warranty does not include any labor charge for removal of defective parts or installation of replacement parts or transportation charges to or from our factory. This warranty does not apply to any equipment sold or supplied by ARCTIC, but manufactured by others and covered by their separate warranties and not by this warranty.

THIS WARRANTY IS EXPRESSLY IMPLIED IN LIEU OF ANY OTHER WARRANTIES, EXPRESSED OR IMPLIED, INCLUDING ANY IMPLIED WARRANTY OF MERCHANTABILITY OR FITNESS FOR A PARTICULAR PURPOSE AND OF ALL OTHER LIABILITIES OR OBLIGATIONS WHATSOEVER, ON ARCTIC'S PART, UNDER NO CIRCUMSTANCES, WHATEVER, SHALL ARCTIC BE LIABLE TO THE PURCHASER OR ANY OTHER PARTY FOR ANY SPECIAL OR CONSEQUENTIAL DAMAGES.







WALK-IN COOLERS & FREEZERS

**Manufactured By:**

Arctic Industries, Inc.

9731 N.W. 114<sup>th</sup> Way, Miami, FL 33178

(305) 883-5581 • Fax: (305) 883-4651

Toll Free: (800) 325-0123

<http://www.arcticwalkins.com>